

Product: John Deere 1600, 1620, and 1600 Turbo Wide Area Mower Service Repair Technical Manual
Full Download: <https://www.bobmanualstore.com/downloads/john-deere-1600-1620-and-1600-turbo-wide-area-mower-service-repair-technical-manual/>

JOHN DEERE
WORLDWIDE COMMERCIAL & CONSUMER
EQUIPMENT DIVISION

Wide Area Mower
1600, 1620, and 1600 Turbo

TM1682 DEC05

TECHNICAL MANUAL



JOHN DEERE

North American Version
Litho in U.S.A.

Sample manual. Download All 688 pages at:

[https://www.bobmanualstore.com/downloads/john-deere-1600-1620-and-1600-turbo-wide-area-mower-service-repair-technical-](https://www.bobmanualstore.com/downloads/john-deere-1600-1620-and-1600-turbo-wide-area-mower-service-repair-technical-manual/)

Product: John Deere 1600, 1620, and 1600 Turbo Wide Area Mower Service Repair Technical Manual
Full Download: <https://www.bobmanualstore.com/downloads/john-deere-1600-1620-and-1600-turbo-wide-area-mower-service-repair-technical-manual/>

Sample manual. Download All 688 pages at:

[https://www.bobmanualstore.com/downloads/john-deere-1600-1620-and-1600-turbo-wide-area-mower-service-repair-technical-](https://www.bobmanualstore.com/downloads/john-deere-1600-1620-and-1600-turbo-wide-area-mower-service-repair-technical-manual/)

INTRODUCTION

Manual Description

This technical manual is written for an experienced technician and contains sections that are specifically for this product. It is a part of a total product support program.

The manual is organized so that all the information on a particular system is kept together. The order of grouping is as follows:

- Table of Contents
- Specifications and Information
- Identification Numbers
- Tools and Materials
- Component Location
- Schematics and Harnesses
- Theory of Operation
- Operation and Diagnostics
- Diagnostics
- Tests and Adjustments
- Repair
- Other

NOTE: Depending on the particular section or system being covered, not all of the above groups may be used.

The bleed tabs for the pages of each section will align with the sections listed on this page. Page numbering is consecutive from the beginning of the Safety section through the last section.

We appreciate your input on this manual. If you find any errors or want to comment on the layout of the manual please contact us.

Safety

Specifications and Information

Engine

Electrical

Power Train

Hydraulics

Steering

Brakes

Attachments

Miscellaneous

All information, illustrations and specifications in this manual are based on the latest information at the time of publication. The right is reserved to make changes at any time without notice.

COPYRIGHT© 2005
Deere & Co.
John Deere Worldwide Commercial and
Consumer Equipment Division
All rights reserved
Previous Editions
COPYRIGHT© 2002

INTRODUCTION

SAFETY

Recognize Safety Information

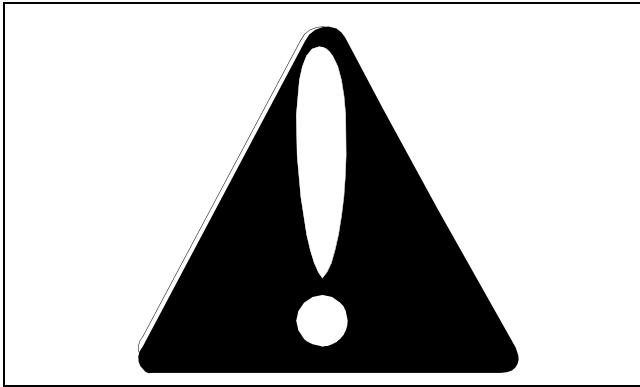

MIF

This is the safety-alert symbol. When you see this symbol on your machine or in this manual, be alert to the potential for personal injury.

Follow recommended precautions and safe servicing practices.

Understand Signal Words

A signal word - DANGER, WARNING, or CAUTION - is used with the safety-alert symbol. DANGER identifies the most serious hazards.

DANGER or WARNING safety signs are located near specific hazards. General precautions are listed on CAUTION safety signs. CAUTION also calls attention to safety messages in this manual.

Replace Safety Signs

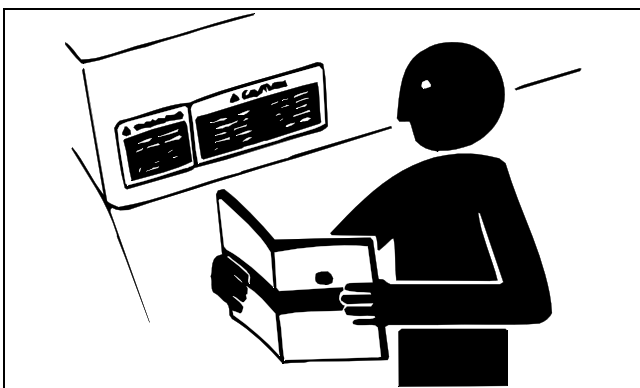

MIF

Replace missing or damaged safety signs. See the machine operator's manual for correct safety sign placement.

Be Prepared for Emergencies

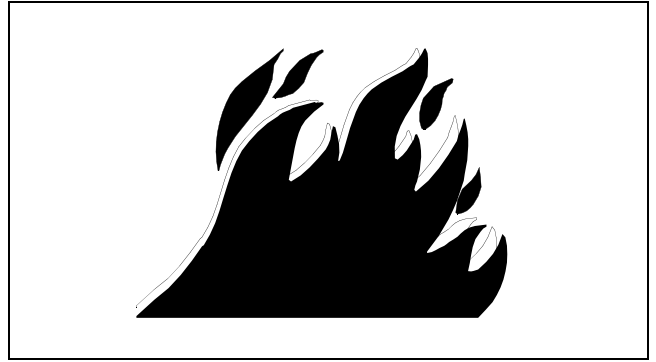

MIF

When you work around fuel, do not smoke or work near heaters or other fire hazards.

Store flammable fluids away from fire hazards. Do not incinerate or puncture pressurized containers.

Make sure machine is clean of trash, grease, and debris.

Do not store oily rags; they can ignite and burn spontaneously.

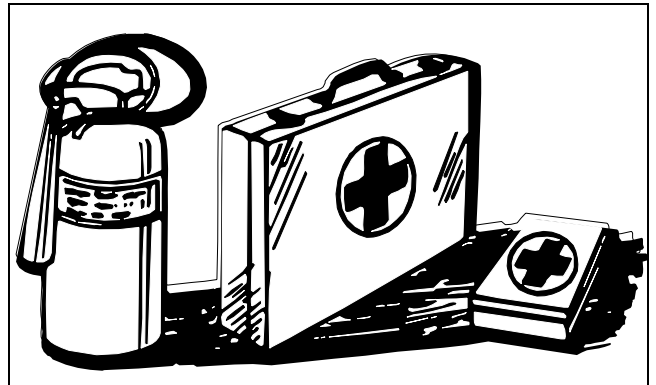

MIF

Be prepared if a fire starts.

Keep a first aid kit and fire extinguisher handy.

Keep emergency numbers for doctors, ambulance service, hospital, and fire department near your telephone.

SAFETY

Prevent Battery Explosions

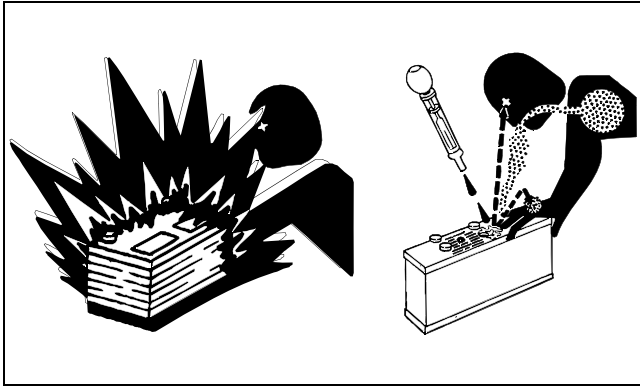

MIF

- Keep sparks, lighted matches, and open flame away from the top of battery. Battery gas can explode.
- Never check battery charge by placing a metal object across the posts. Use a voltmeter or hydrometer.
- Do not charge a frozen battery; it may explode. Warm battery to 16°C (60°F).

Prevent Acid Burns

- Sulfuric acid in battery electrolyte is poisonous. It is strong enough to burn skin, eat holes in clothing, and cause blindness if splashed into eyes.
- **Avoid acid burns by:**
 - a. Filling batteries in a well-ventilated area.
 - b. Wearing eye protection and rubber gloves.
 - c. Avoiding breathing fumes when electrolyte is added.
 - d. Avoiding spilling or dripping electrolyte.
 - e. Using proper jump start procedure.
- **If you spill acid on yourself:**
 - a. Flush your skin with water.
 - b. Apply baking soda or lime to help neutralize the acid.
 - c. Flush your eyes with water for 10-15 minutes.
 - d. Get medical attention immediately.
- **If acid is swallowed:**
 - a. Drink large amounts of water or milk.
 - b. Then drink milk of magnesia, beaten eggs, or vegetable oil.
 - c. Get medical attention immediately.

Avoid High-Pressure Fluids

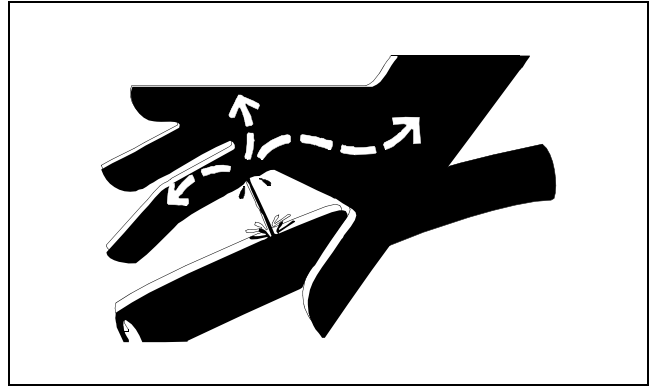

MIF

Escaping fluid under pressure can penetrate the skin causing serious injury. Avoid the hazard by relieving pressure before disconnecting hydraulic or other lines. Tighten all connections before applying pressure. Search for leaks with a piece of cardboard. Protect hands and body from high-pressure fluids.

If an accident occurs, see a doctor immediately. Any fluid injected into the skin must be surgically removed within a few hours or gangrene may result. Doctors unfamiliar with this type of injury should reference a knowledgeable medical source. Such information is available from Deere & Company Medical Department in Moline, Illinois, U.S.A. Information may be obtained in the United States and Canada only by calling 1-800-822-8262.

Avoid Heating Near Pressurized Fluid Lines

Flammable spray can be generated by heating near pressurized fluid lines, resulting in severe burns to yourself and bystanders. Do not heat by welding, soldering, or using a torch near pressurized fluid lines or other flammable materials. Pressurized lines can be accidentally cut when heat goes beyond the immediate flame area.

Use Proper Tools

Use tools appropriate to the work. Makeshift tools and procedures can create safety hazards. Use power tools only to loosen threaded parts and fasteners. For loosening and tightening hardware, use the correct size tools. DO NOT use U.S. measurement tools on metric fasteners. Avoid bodily injury caused by slipping wrenches. Use only service parts meeting John Deere specifications.

SAFETY

Wear Protective Clothing

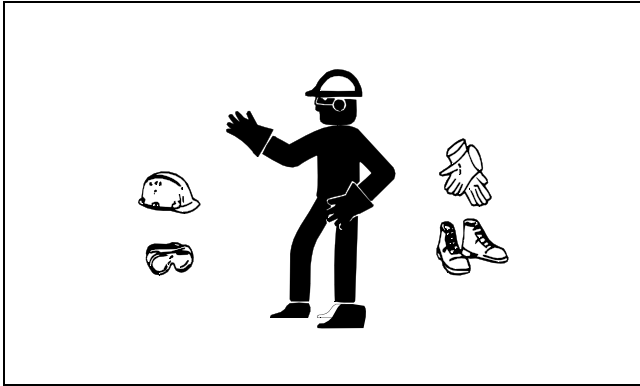

MIF

Wear close fitting clothing and safety equipment appropriate to the job.

Prolonged exposure to loud noise can cause impairment or loss of hearing. Wear a suitable hearing protective device such as earmuffs or earplugs to protect against objectionable or uncomfortable loud noises.

Operating equipment safely requires the full attention of the operator. Do not wear radio or music headphones while operating machine.

Service Machines Safely

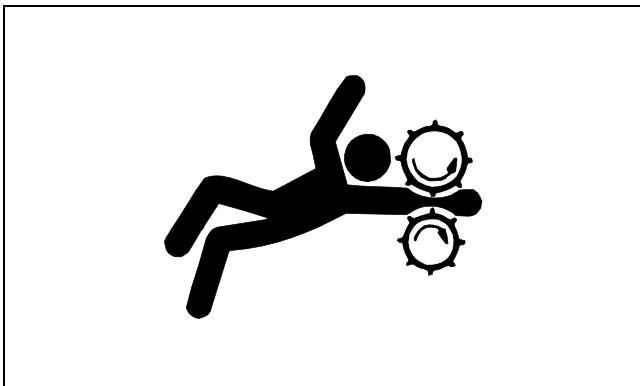

MIF

Tie long hair behind your head. Do not wear a necktie, scarf, loose clothing, or necklace when you work near machine tools or moving parts. If these items were to get caught, severe injury could result.

Remove rings and other jewelry to prevent electrical shorts and entanglement in moving parts.

Park Machine Safely

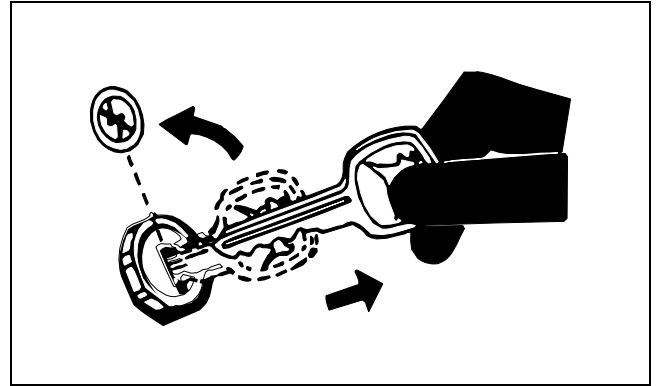

MIF

Before working on the machine:

1. Lower all equipment to the ground.
2. Stop the engine and remove the key.
3. Disconnect the battery ground strap.
4. Hang a "DO NOT OPERATE" tag in operator station.

Support Machine Properly and Use Proper Lifting Equipment

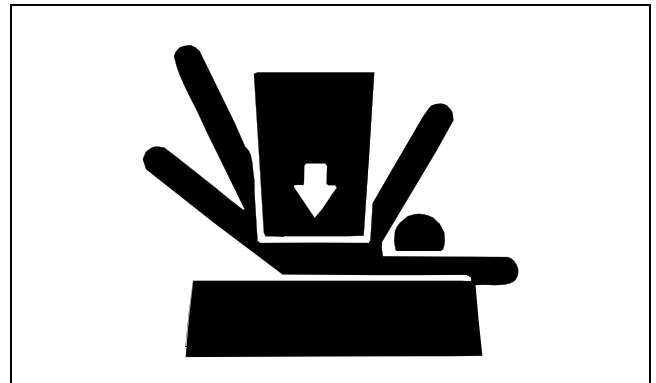

MIF

If you must work on a lifted machine or attachment, securely support the machine or attachment.

Do not support the machine on cinder blocks, hollow tiles, or props that may crumble under continuous load. Do not work under a machine that is supported solely by a jack. Follow recommended procedures in this manual.

Lifting heavy components incorrectly can cause severe injury or machine damage. Follow recommended procedure for removal and installation of components in the manual.

SAFETY

Work in Clean Area

Before starting a job:

1. Clean work area and machine.
2. Make sure you have all necessary tools to do your job.
3. Have the right parts on hand.
4. Read all instructions thoroughly; do not attempt shortcuts.

Using High-Pressure Washers

Directing pressurized water at electronic/electrical components or connectors, bearings, hydraulic seals, fuel injection pumps or other sensitive parts and components may cause product malfunctions. Reduce pressure and spray at a 45 to 90 degree angle.

Illuminate Work Area Safely

Illuminate your work area adequately but safely. Use a portable safety light for working inside or under the machine. Make sure the bulb is enclosed by a wire cage. The hot filament of an accidentally broken bulb can ignite spilled fuel or oil.

Work in Ventilated Area

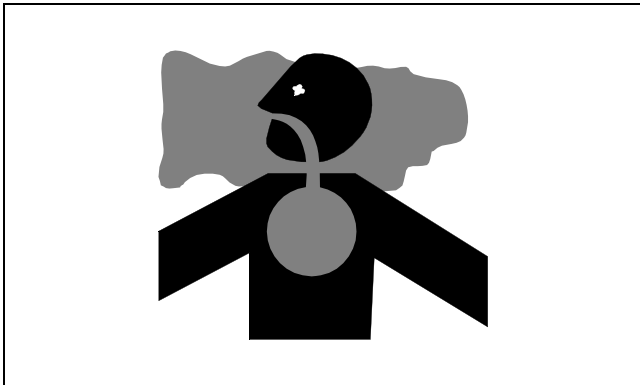

MIF

Engine exhaust fumes can cause sickness or death. If it is necessary to run an engine in an enclosed area, remove the exhaust fumes from the area with an exhaust pipe extension.

If you do not have an exhaust pipe extension, open the doors and get outside air into the area.

WARNING: California Proposition 65 Warning

Gasoline engine exhaust from this product contains chemicals known to the State of California to cause cancer, birth defects, or other reproductive harm.

Remove Paint before Welding or Heating

Avoid potentially toxic fumes and dust. Hazardous fumes can be generated when paint is heated by welding, soldering, or using a torch. Do all work outside or in a well-ventilated area. Dispose of paint and solvent properly. Remove paint before welding or heating. If you sand or grind paint, avoid breathing the dust. Wear an approved respirator. If you use solvent or paint stripper, remove stripper with soap and water before welding. Remove solvent or paint stripper containers and other flammable material from area. Allow fumes to disperse at least 15 minutes before welding or heating.

Avoid Harmful Asbestos Dust

Avoid breathing dust that may be generated when handling components containing asbestos fibers. Inhaled asbestos fibers may cause lung cancer.

Components in products that may contain asbestos fibers are brake pads, brake band and lining assemblies, clutch plates, and some gaskets. The asbestos used in these components is usually found in a resin or sealed in some way. Normal handling is not hazardous as long as airborne dust containing asbestos is not generated.

Avoid creating dust. Never use compressed air for cleaning. Avoid brushing or grinding material containing asbestos. When servicing, wear an approved respirator. A special vacuum cleaner is recommended to clean asbestos. If not available, apply a mist of oil or water on the material containing asbestos. Keep bystanders away from the area.

Service Cooling System Safely

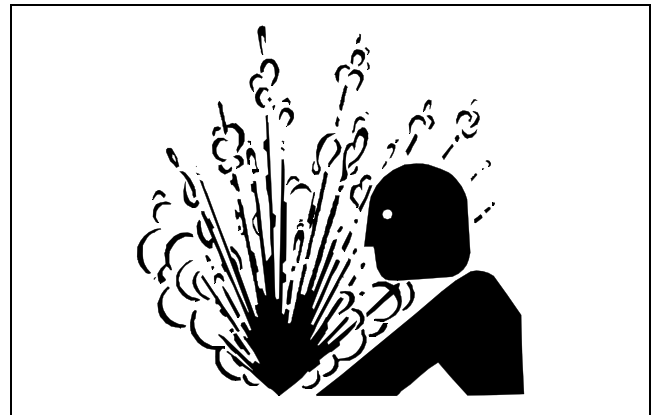

MIF

Explosive release of fluids from pressurized cooling system can cause serious burns.

Shut off machine. Remove filler cap only when cool enough to touch with bare hands. Slowly loosen cap to first stop to relieve pressure before removing completely.

SAFETY

Service Tires Safely

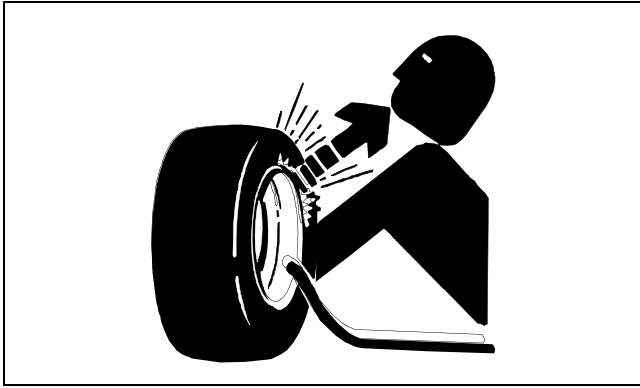

MIF

Explosive separation of a tire and rim parts can cause serious injury or death.

- Do not attempt to mount a tire unless you have the proper equipment and experience to perform the job.
- Always maintain the correct tire pressure. Do not inflate the tires above the recommended pressure. Never weld or heat a wheel and tire assembly. The heat can cause an increase in air pressure resulting in a tire explosion. Welding can structurally weaken or deform the wheel.
- When inflating tires, use a clip-on chuck and extension hose long enough to allow you to stand to one side and NOT in front of or over the tire assembly. Use a safety cage if available.
- Check wheels for low pressure, cuts, bubbles, damaged rims or missing lug bolts and nuts.

Avoid Injury from Rotating Blades, Augers, and PTO Shafts

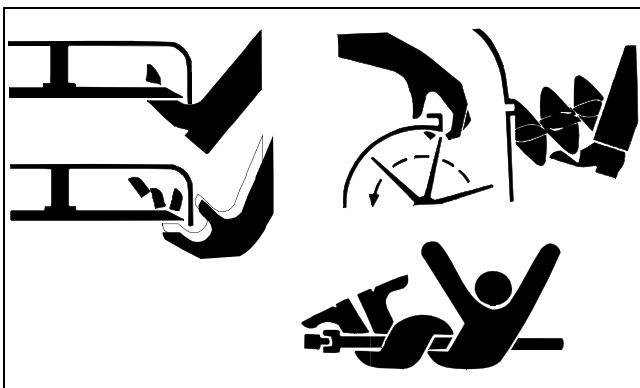

MIF

Keep hands and feet away while machine is running. Shut off power to service, lubricate, or remove mower blades, augers, or PTO shafts.

Handling Fuel Safely

Fuel and fuel vapors are highly flammable:



MIF

- Do not refuel machine while you smoke, when machine is near an open flame or sparks, or when engine is running. Stop engine and allow to cool before filling.
- Never remove the fuel cap or add fuel with the engine running.
- Never fill fuel tank or drain fuel from a machine in an enclosed area. Fill fuel tank outdoors.
- Prevent fires. Clean up spilled fuel immediately.
- Do not store machine with fuel in tank in a building where fumes may reach an open flame or spark.
- Prevent fire and explosion caused by static electric discharge. Use only non-metal, portable fuel containers approved by the Underwriter's Laboratory (U.L.) or the American Society for Testing & Materials (ASTM). If using a funnel, make sure it is plastic and has no screen or filter.

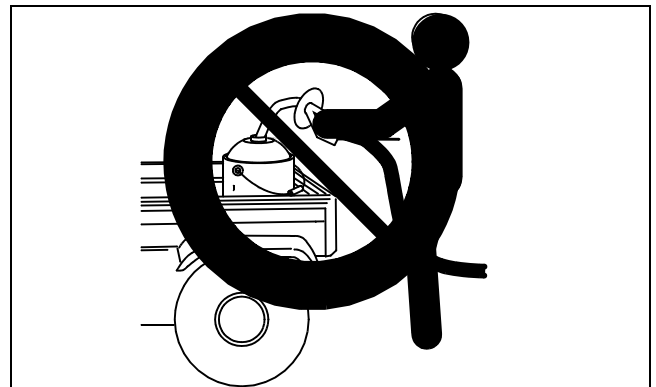

MIF

- Static electric discharge can ignite gasoline vapors in an ungrounded fuel container. Remove the fuel container from the bed of a vehicle or the trunk of a car and place on the ground away from the vehicle before filling. Keep nozzle in contact with container opening while filling.

SAFETY

- When practical, remove equipment from trailers or truck beds and refuel them on the ground. If this is not possible, use a portable, plastic fuel container to refuel equipment on a truck bed or trailer.
- For gasoline engines, do not use gas with methanol. Methanol is harmful to your health and to the environment.

Handle Chemical Products Safely

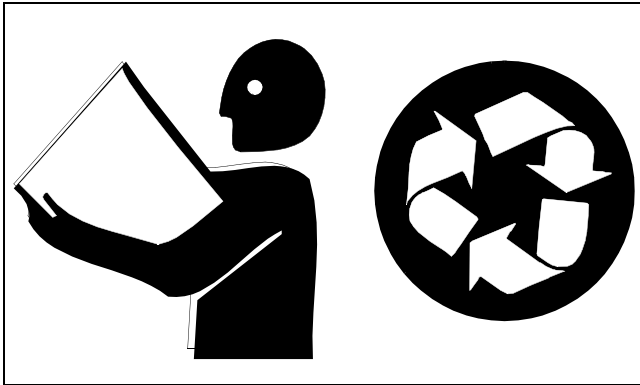

MIF

Direct exposure to hazardous chemicals can cause serious injury. Potentially hazardous chemicals used with John Deere equipment include such items as lubricants, coolants, paints, and adhesives.

A Material Safety Data Sheet (MSDS) provides specific details on chemical products: physical and health hazards, safety procedures, and emergency response techniques. Check the MSDS before you start any job using a hazardous chemical. That way you will know exactly what the risks are and how to do the job safely. Then follow procedures and recommended equipment.

Dispose of Waste Properly

Improperly disposing of waste can threaten the environment and ecology. Potentially harmful waste used with John Deere equipment includes such items as oil, fuel, coolant, brake fluid, filters, and batteries. Use leakproof containers when draining fluids. Do not use food or beverage containers that may mislead someone into drinking from them. Do not pour waste onto the ground, down a drain, or into any water source. Inquire on the proper way to recycle or dispose of waste from your local environmental or recycling center, or from your John Deere dealer.

Live with Safety



MIF

Before returning machine to customer, make sure machine is functioning properly, especially the safety systems. Install all guards and shields.

SPECIFICATIONS AND INFORMATION TABLE OF CONTENTS

Table of Contents

Specifications	9
Engine (Yanmar TNE Engines)	9
Engine (Yanmar TNV Engines)	9
Capacities.....	10
Travel Speeds	10
Tire Dimensions	10
Tire Inflation Pressures	10
Dimensions.....	10
Mower Decks.....	11
Recommended Lubricants	11
Repair Specifications	12
Metric Fastener Torque Values	12
Metric Fastener Torque Values - Grade 7 ...	13
Inch Fastener Torque Values	14
Hydraulic Fitting Service Recommendations	15
O-Ring Face Seal Fittings	18
O-Ring Boss Fittings	18
Diesel Fuel Specifications	19
4-Cycle Diesel Engine Oil.....	19
Hydrostatic Transmission and Hydraulic Oil	20
Mechanical Four Wheel Drive (MFWD) Oil ..	20
Anti-Corrosion Grease.....	21
Chassis and Roller Water Resistant Grease	21
Chassis and Mower Spindle Grease	22
Diesel and Gasoline Engine Coolant.....	22
Diesel and Gasoline Engine Coolant Drain Interval.....	23
General Information	23
Interlock System.....	23
Product Identification	25
Record Identification Numbers	25

SPECIFICATIONS AND INFORMATION TABLE OF CONTENTS



SPECIFICATIONS AND INFORMATION SPECIFICATIONS

Specifications

Engine (Yanmar TNE Engines)

Engine Model Number - 1600 and 1620	Yanmar 4TNE88
Engine Model Number - 1600 Turbo	Yanmar 4TNE84T
Engine Type	4-Cycle, 4-Cylinder, In-Line Turbocharged Diesel
Cooling	Liquid Cooled
Slow Idle Speed	700 rpm
Fast Idle Speed (Non-adjustable)	3200±50 rpm
Injection Type	Direct
Air Cleaner	Dry, Replaceable Dual Element

Bore x Stroke

4TNE88	88x90 mm (3.465x3.540 in.)
4TNE84T	84x90 mm (3.307x3.540 in.)

Displacement

4TNE88	2.19 L (133.6 cu in.)
4TNE84T	2.0 L (122 cu in.)

Gross Output

4TNE88	38 kW (51 hp)
4TNE84T	44 kW (59 hp)

Net Output

4TNE88	37 kW (49 hp)
4TNE84T	42.7 kW (57.3 hp)

Engine (Yanmar TNV Engines)

Engine Model Number - 1600 Turbo	Yanmar 4TNV84T
Engine Type	4-Cycle, 4-Cylinder, In-Line Turbocharged Diesel
Cooling	Liquid Cooled
Slow Idle Speed	700 rpm
Fast Idle Speed (Non-adjustable)	3200±50 rpm
Injection Type	Direct
Air Cleaner	Dry, Replaceable Dual Element
Bore x Stroke	84x90 mm (3.307x3.540 in.)
Displacement	2.0 L (122 cu in.)
Gross Output	44 kW (59 hp)
Net Output	42.7 kW (57.3 hp)

SPECIFICATIONS AND INFORMATION SPECIFICATIONS

Capacities

Engine Oil (with Filter) (TNE Engine)	6.6 L (7 qt)
Engine Oil (with Filter) (TNV Engine)	7.4 L (7.8 qt)
Fuel Tank	83 L (22 gal)
Coolant	7.5 L (8 qt)
Hydraulic System	58.7 L (15.5 gal)
Hydraulic System - 1600 Turbo S.N. (050001-)	50.7 L (13.4 gal)
Hydrostatic Transmission	13.3 L (3.5 gal)
Rear Axle	4.7 L (5 qt)

Travel Speeds

High Range

Forward	0–23.3 km/h (0–14.4 mph)
Reverse	0–11.6 km/h (0–7.2 mph)

Low Range

Forward	0–13.7 km/h (0–8.6 mph)
Reverse	0–7.2 km/h (0–4.3 mph)

Tire Dimensions

Front Drive Tire ¹	26x12.00-12 (4 ply)
Rear Tire ¹	20x10-8 (4 ply)
Front Drive Tire - 1600 Turbo S.N. (040001-)	26x12.00-12 (6 ply)
Rear Tire - 1600 Turbo S.N. (040001-)	18x9.5-8 (6 ply)
Mower Deck Caster Tire	11x4-5

Tire Inflation Pressures

Machine Front Tire ¹	138 kPa (20 psi)
Machine Rear Tire ¹	138 kPa (20 psi)
Machine Front Tire - 1600 Turbo S.N. (040001-)	207 kPa (30 psi)
Machine Rear Tire - 1600 Turbo S.N. (040001-)	193 kPa (28 psi)
Mower Deck Caster Tire	275 kPa (40 psi)

Dimensions

Height	2 m (78 in.)
Width (Mower Decks Raised)	2.2 m (84.5 in.)
Width (Mower Decks Lowered)	3.3 m (131 in.)
Length (With Mower Deck)	3.4 m (133 in.)
Length (Without Mower Deck)	2.6 m (101 in.)
Wheelbase	1.6 m (61 in.)
Weight (With Mower Decks)	1814 kg (4000 lbs)
Ground Clearance	18 cm (7 in.)
Cutting Width	3.3 m (131 in.)

1. 1600 Turbo S.N. (-040000) see SIB 05-11-70-2

SPECIFICATIONS AND INFORMATION SPECIFICATIONS

Mower Decks

Front Mower Deck

Cutting Width	1.6 m (62 in.)
Cutting Height.....	2.5–15.2 cm (1–6 in.)
Number of Blades.....	3

Side Mower Decks

Cutting Width	1 m (40 in.)
Cutting Height.....	2.5–14 cm (1–5.5 in.)
Number of Blades.....	2

Recommended Lubricants

Engine Oil	John Deere PLUS-50™ (15W-40)
.....	John Deere TORQ-GARD™ Supreme (5W-30)
Engine Coolant	John Deere COOL-GARD™ Pre-Diluted Diesel Engine Anti-Freeze/Summer Coolant™
.....	John Deere COOL-GARD™ Diesel Engine Anti-Freeze/Summer Coolant Concentrate™
Hydraulic Oil	John Deere HY-GARD™ J20C
Hydrostatic Oil	John Deere HY-GARD™ J20C
Grease	See Service Lubrication Section

SPECIFICATIONS AND INFORMATION REPAIR SPECIFICATIONS

Repair Specifications

Metric Fastener Torque Values

Property Class and Head Markings				
Property Class and Nut Markings				

MIF (TS1163)

SIZE	Class 4.8		Class 8.8 or 9.8				Class 10.9				Class 12.9					
	Lubricated ¹		Dry ¹		Lubricated ¹		Dry ¹		Lubricated ¹		Dry ¹		Lubricated ¹		Dry ¹	
	N•m	lb-ft	N•m	lb-ft	N•m	lb-ft	N•m	lb-ft	N•m	lb-ft	N•m	lb-ft	N•m	lb-ft	N•m	lb-ft
M6	4.8	3.5	6	4.5	9	6.5	11	8.5	13	9.5	17	12	15	11.5	19	14.5
M8	12	8.5	15	11	22	16	28	20	32	24	40	30	37	28	47	35
M10	23	17	29	21	43	32	55	40	63	47	80	60	75	55	95	70
M12	40	29	50	37	75	55	95	70	110	80	140	105	130	95	165	120
M14	63	47	80	60	120	88	150	110	175	130	225	165	205	150	260	109
M16	100	73	125	92	190	140	240	175	275	200	350	225	320	240	400	300
M18	135	100	175	125	260	195	330	250	375	275	475	350	440	325	560	410
M20	190	140	240	180	375	275	475	350	530	400	675	500	625	460	800	580
M22	260	190	330	250	510	375	650	475	725	540	925	675	850	625	1075	800
M24	330	250	425	310	650	475	825	600	925	675	1150	850	1075	800	1350	1000
M27	490	360	625	450	950	700	1200	875	1350	1000	1700	1250	1600	1150	2000	1500
M30	675	490	850	625	1300	950	1650	1200	1850	1350	2300	1700	2150	1600	2700	2000
M33	900	675	1150	850	1750	1300	2200	1650	2500	1850	3150	2350	2900	2150	3700	2750
M36	1150	850	1450	1075	2250	1650	2850	2100	3200	2350	4050	3000	3750	2750	4750	3500

1. "Lubricated" means coated with a lubricant such as engine oil, or fasteners with phosphate and oil coatings. "Dry" means plain or zinc plated (yellow dichromate - Specification JDS117) without any lubrication.

DO NOT use these hand torque values if a different torque value or tightening procedure is given for a specific application. Torque values listed are for general use only and include a $\pm 10\%$ variance factor. Check tightness of fasteners periodically. DO NOT use air powered wrenches.

Shear bolts are designed to fail under predetermined loads. Always replace shear bolts with identical grade.

Fasteners should be replaced with the same class. Make sure fastener threads are clean and that you properly start

thread engagement. This will prevent them from failing when tightening.

When bolt and nut combination fasteners are used, torque values should be applied to the NUT instead of the bolt head.

Tighten toothed or serrated-type lock nuts to the full torque value.

Reference: JDS-G200.







SPECIFICATIONS AND INFORMATION REPAIR SPECIFICATIONS

Metric Fastener Torque Values - Grade 7

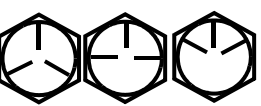
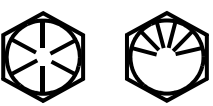
Size	Steel or Gray Iron Torque		Aluminum Torque	
	N•m	lb-ft	N•m	lb-ft
M6	11	8	8	6
M8	24	18	19	14
M10	52	38	41	30
M12	88	65	70	52
M14	138	102	111	82
M16	224	165	179	132

SPECIFICATIONS AND INFORMATION REPAIR SPECIFICATIONS

Inch Fastener Torque Values

SAE Grade and Head Markings	1 or 2 ¹ No Marks 	5 5.1 5.2 	8 8.2 
SAE Grade and Nut Markings	No Marks 	5  	8  

MIF (TS1162)

SIZE	Grade 1		Grade 2 ¹		Grade 5, 5.1 or 5.2		Grade 8 or 8.2									
	Lubricated ²	Dry ²	Lubricated ²	Dry ²	Lubricated ²	Dry ²	Lubricated ²	Dry ²								
	N•m	lb-ft	N•m	lb-ft	N•m	lb-ft	N•m	lb-ft								
1/4	3.7	2.8	4.7	3.5	6	4.5	7.5	5.5	9.5	7	12	9	13.5	10	17	12.5
5/16	7.7	5.5	10	7	12	9	15	11	20	15	25	18	28	21	35	26
3/8	14	10	17	13	22	16	27	20	35	26	44	33	50	36	63	46
7/16	22	16	28	20	35	26	44	32	55	41	70	52	80	58	100	75
1/2	33	25	42	31	53	39	67	50	85	63	110	80	120	90	150	115
9/16	48	36	60	45	75	56	95	70	125	90	155	115	175	130	225	160
5/8	67	50	85	62	105	78	135	100	170	125	215	160	215	160	300	225
3/4	120	87	150	110	190	140	240	175	300	225	375	280	425	310	550	400
7/8	190	140	240	175	190	140	240	175	490	360	625	450	700	500	875	650
1	290	210	360	270	290	210	360	270	725	540	925	675	1050	750	1300	975
1-1/8	470	300	510	375	470	300	510	375	900	675	1150	850	1450	1075	1850	1350
1-1/4	570	425	725	530	570	425	725	530	1300	950	1650	1200	2050	1500	2600	1950
1-3/8	750	550	950	700	750	550	950	700	1700	1250	2150	1550	2700	2000	3400	2550
1-1/2	1000	725	1250	925	990	725	1250	930	2250	1650	2850	2100	3600	2650	4550	3350

1. "Grade 2" applies for hex cap screws (not hex bolts) up to 152 mm (6-in.) long. "Grade 1" applies for hex cap screws over 152 mm (6-in.) long, and for all other types of bolts and screws of any length.

2. "Lubricated" means coated with a lubricant such as engine oil, or fasteners with phosphate and oil coatings. "Dry" means plain or zinc plated (yellow dichromate - Specification JDS117) without any lubrication.

DO NOT use these hand torque values if a different torque value or tightening procedure is given for a specific application. Torque values listed are for general use only and include a ±10% variance factor. Check tightness of fasteners periodically. DO NOT use air powered wrenches.

Shear bolts are designed to fail under predetermined loads. Always replace shear bolts with identical grade.

Fasteners should be replaced with the same grade. Make sure fastener threads are clean and that you properly start

thread engagement. This will prevent them from failing when tightening.

When bolt and nut combination fasteners are used, torque values should be applied to the NUT instead of the bolt head.

Tighten toothed or serrated-type lock nuts to the full torque value.

Reference: JDS-G200.

SPECIFICATIONS AND INFORMATION REPAIR SPECIFICATIONS

Hydraulic Fitting Service Recommendations

37° and 45° JIC/SAE Flare Fitting Torques

NOTE: Torque tolerance is + 15 - 20%

Nominal Tube OD/Hose ID				37° and 45° JIC Flare Tube/Hose End		
Metric Tube OD		Inch Tube OD		Thread Size	Tube Nut/ Swivel Nut Torque	
mm	Dash Size	in.	mm	in.	N•m	lb-ft
6	-4	0.250	6.35	7/16-20	16	12
8	-5	0.312	7.94	1/2-20	21	15
10	-6	0.375	9.52	9/16-18	29	21
12	-8	0.500	12.70	3/4-16	63	46
16	-10	0.625	15.88	7/8-14	74	54
	-12	0.750	19.05	1-1/16-12	113	85
25	-16	1.000	25.40	1-5/16	164	121
32	-20	1.25	31.75	1-5/8-12	226	167
38	-24	1.50	38.10	1-7/8-12	271	200

Straight Fitting or Special Nut Torque

Thread Size	Torque ¹		Number of Flats ²
	N•m	lb-ft	
3/8-24 UNF	8	(6)	2
7/16-20 UNF	12	(9)	2
1/2-20 UNF	16	(12)	2
9/16-18 UNF	24	(18)	2
3/4-16 UNF	46	(34)	2
7/8-14 UNF	62	(46)	1-1/2
1-1/16-12 UN	102	(75)	1
1-3/16-12 UN	122	(90)	1
1-5/16-12 UN	142	(105)	3/4
1-5/8-12 UN	190	(140)	3/4
1-7/8-12 UN	217	(160)	1/2

1. Torque tolerance is ± 10 percent.

2. To be used if a torque wrench cannot be used. After tightening fitting by hand, put a mark on nut or boss; then tighten special nut or straight fitting the number of flats shown.

SPECIFICATIONS AND INFORMATION REPAIR SPECIFICATIONS

Face Seal Fittings with Inch Stud End Torques

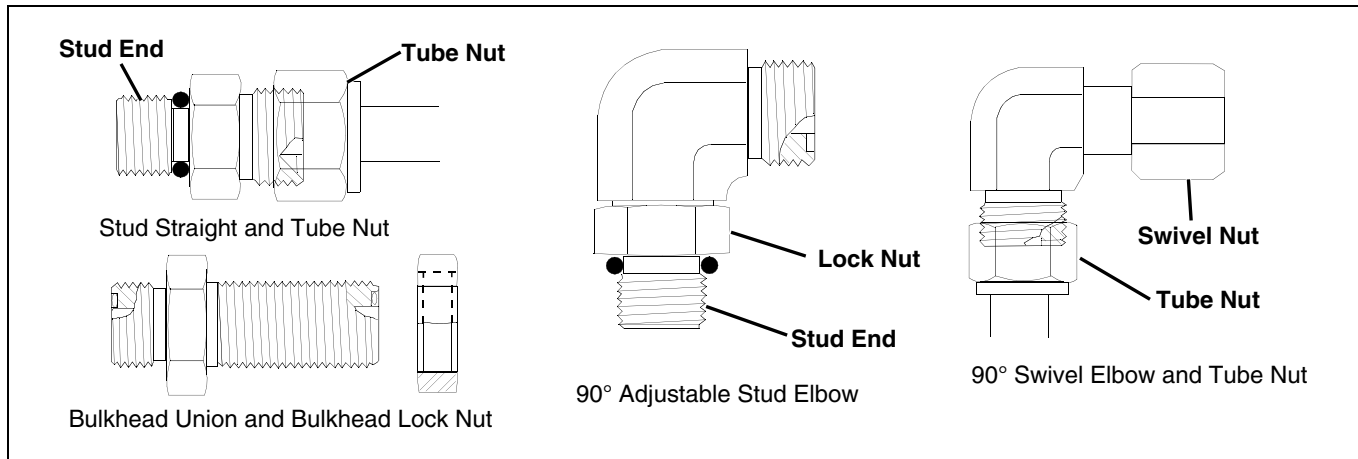

MIF

NOTE: Torque tolerance is + 15 - 20%

Nominal Tube OD/Hose ID				Face Seal Tube/Hose End					O-Ring Stud Ends		
Metric Tube OD	Inch Tube OD			Thread Size	Tube Nut/ Swivel Nut Torque		Bulkhead Lock Nut Torque		Thread Size	Straight Fitting of Lock Nut Torque	
	Dash Size	in.	mm		in.	N•m	lb-ft	N•m		lb-ft	in.
	-3	0.188	4.76						3/8-24	8	6
6	-4	0.250	6.35	9/16-18	16	12	12	9	7/16-20	12	9
8	-5	0.312	7.94						1/2-20	16	12
10	-6	0.375	9.52	11/16-16	24	18	24	18	9/16-18	24	18
12	-8	0.500	12.70	13/16-16	50	37	46	34	3/4-16	46	34
16	-10	0.625	15.88	1-14	69	51	62	46	7/8-14	62	46
	-12	0.750	19.05	1-3/16-12	102	75	102	75	1-1/16-12	102	75
22	-14	0.875	22.22	1-3/16-12	102	75	102	75	1-3/16-12	122	90
25	-16	1.000	25.40	1-7/16-12	142	105	142	105	1-5/16	142	105
32	-20	1.25	31.75	1-11/16-12	190	140	190	140	1-5/8-12	190	140
38	-24	1.50	38.10	2-12	217	160	217	160	1-7/8-12	217	160

SPECIFICATIONS AND INFORMATION REPAIR SPECIFICATIONS

Face Seal Fittings with Metric Stud End Torques

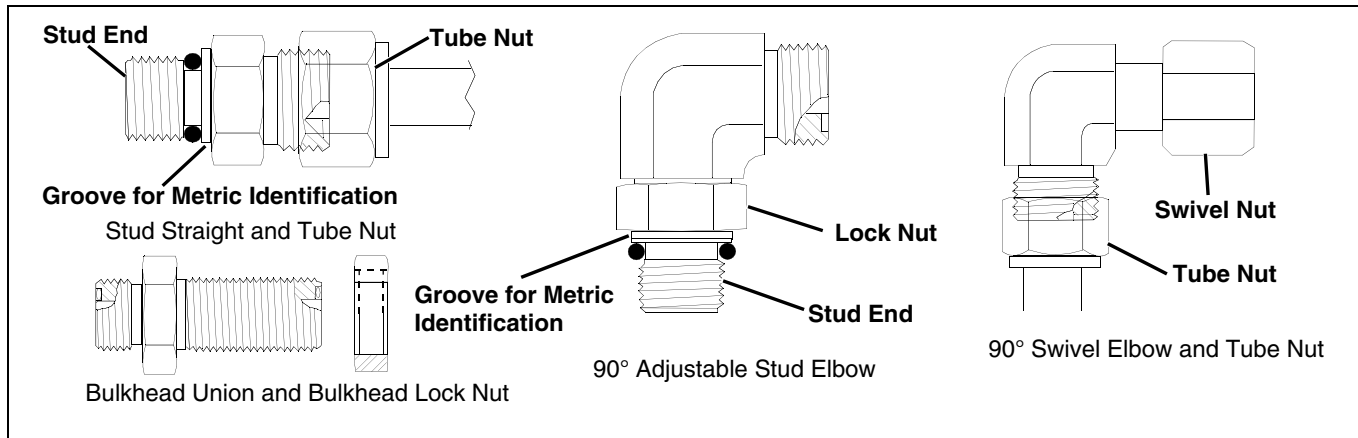

MIF

NOTE: Torque tolerance is + 15% - 20%

Nominal Tube OD/Hose ID				Face Seal Tube/Hose End						O-Ring Stud Ends, Straight Fitting or Lock Nut					
Metric Tube OD	Inch Tube OD			Thread Size	Hex Size	Tube Nut/ Swivel Nut Torque		Bulkhead Lock Nut Torque		Thread Size	Hex Size	Steel or Gray Iron Torque		Aluminum Torque	
	mm	Dash Size	in.			mm	in.	mm	N•m			lb-ft	N•m	lb-ft	mm
6	-4	0.250	6.35	9/16-18	17	16	12	12	9	M12X1.5	17	21	15.5	9	6.6
8	-5	0.312	7.94												
										M14X1.5	19	33	24	15	11
10	-6	0.375	9.52	11/16-16	22	24	18	24	18	M16X1.5	22	41	30	18	13
12	-8	0.500	12.70	13/16-16	24	50	37	46	34	M18X1.5	24	50	37	21	15
16	-10	0.625	15.88	1-14	30	69	51	62	46	M22X1.5	27	69	51	28	21
	-12	0.750	19.05	1-3/16-12	36	102	75	102	75	M27X2	32	102	75	46	34
22	-14	0.875	22.22	1-3/16-12	36	102	75	102	75	M30X2	36				
25	-16	1.000	25.40	1-7/16-12	41	142	105	142	105	M33X2	41	158	116	71	52
28										M38X2	46	176	130	79	58
32	-20	1.25	31.75	1-11/16-12	50	190	140	190	140	M42X2	50	190	140	85	63
38	-24	1.50	38.10	2-12	60	217	160	217	160	M48X2	55	217	160	98	72

O-Ring Face Seal Fittings

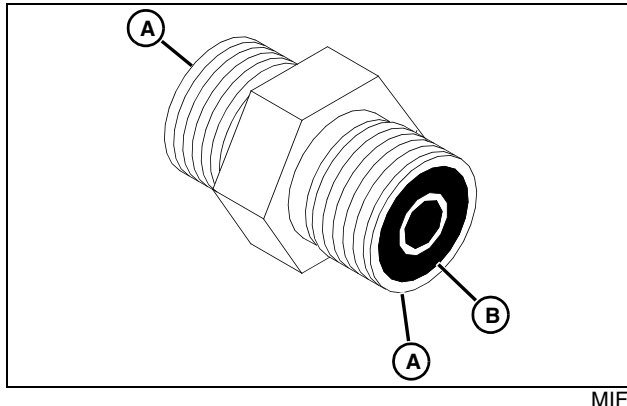

1. Inspect the fitting sealing surfaces (A). They must be free of dirt or defects.
2. Inspect the O-ring (B). It must be free of damage or defects.
3. Lubricate O-rings and install into groove using petroleum jelly to hold in place.
4. Push O-ring into the groove with plenty of petroleum jelly so O-ring is not displaced during assembly.
5. Index angle fittings and tighten by hand-pressing joint together to ensure O-ring remains in place.

IMPORTANT: Avoid damage! DO NOT allow hoses to twist when tightening fittings. Use two wrenches to tighten hose connections; one to hold the hose, and the other to tighten the swivel fitting.

6. Tighten fitting or nut to torque value shown on the chart per dash size stamped on the fitting.

O-Ring Boss Fittings

1. Inspect boss O-ring boss seat. It must be free of dirt and defects. If repeated leaks occur, inspect for defects with a magnifying glass. Some raised defects can be removed with a slip stone.

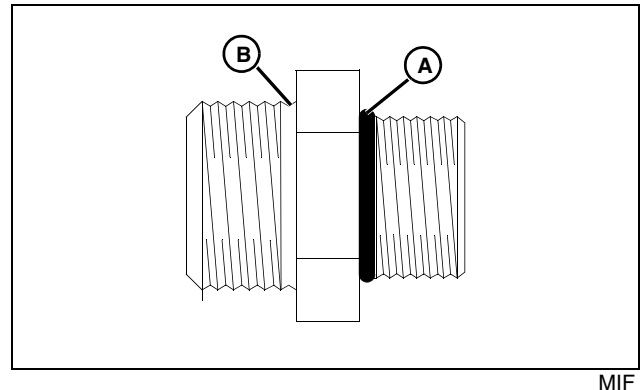

2. Put hydraulic oil or petroleum jelly on the O-ring (A). Place electrical tape over the threads to protect O-ring from nicks. Slide O-ring over the tape and into the groove (B) of fitting. Remove tape.

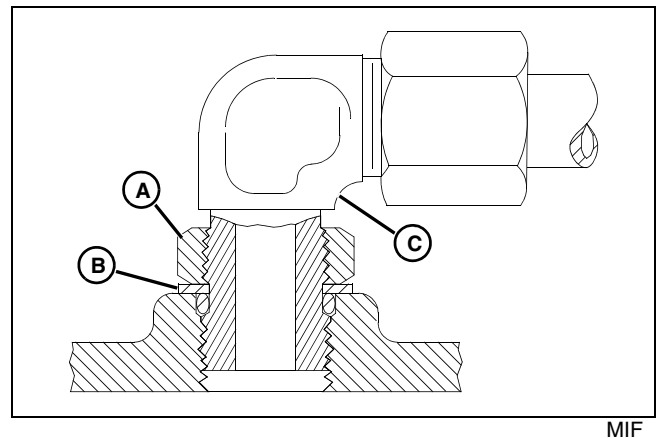

3. For angle fittings, loosen special nut (A) and push special washer (B) against threads so O-ring can be installed into the groove of fitting.
4. Turn fitting into the boss by hand until special washer or washer face (straight fitting) contacts boss face and O-ring is squeezed into its seat.
5. To position angle fittings (C), turn the fitting counter-clockwise a maximum of one turn.
6. Tighten straight fittings to torque value shown on chart. For angle fittings, tighten the special nut to value shown in the chart while holding body of fitting with a wrench.

Diesel Fuel Specifications

In general, diesel fuels are blended to satisfy the low air temperature requirements of the geographical area in which they are sold.

In **North America**, diesel fuel is usually specified to **ASTM D975** and sold as either **Grade 1** for cold air temperatures or **Grade 2** for warm air temperatures.

In **Europe**, diesel fuel is usually specified to **EN590** and sold in 5 different classes or 6 different grades.

If diesel fuels being supplied in your area **DO NOT** meet any of the above specifications, use diesel fuels with the following equivalent properties:

- **Cetane Number 40 (Minimum)**

A cetane number **greater than 50 is preferred**, especially for air temperatures below -20°C (-4°F) or elevations above 1500 m (5000 ft).

- **Cold Filter Plugging Point (CFPP)**

The temperature at which diesel fuel **begins to cloud or jell**. Use diesel fuels with a CFPP which is at least 5°C (9°F) below the expected low air temperature.

- **Sulfur Content of 0.05% (Maximum)**

Diesel fuels for highway use in the United States now require sulfur content to be **less than 0.05%**.

If diesel fuel being used has a sulfur content **greater than 0.5%**, **reduce the service interval for engine oil and filter by 50%**.

Bio-Diesel Fuels with bio-degradable properties that meet specification DIN 51606, or equivalent, may be used.

Consult your local diesel fuel distributor for properties of the diesel fuel available in your area.



CAUTION: Avoid injury! California Proposition 65 Warning: Diesel engine exhaust and some of its elements from this product are known to the State of California to cause cancer, birth defects, or other reproductive harm.

4-Cycle Diesel Engine Oil

Use the appropriate oil viscosity based on the expected air temperature range during the period between recommended oil changes. Operating outside of these recommended oil air temperature ranges may cause premature engine failure.

The following John Deere oils are **PREFERRED**:

- **PLUS-50™ - SAE 15-40**
- **TORQ-GARD SUPREME™ - SAE 5W-30**

The following John Deere oils are **also recommended**, based on their specified temperature range:

- **TURF-GARD™ - SAE 10W-30**
- **PLUS-4™ - SAE 10W-30**
- **TORQ-GARD SUPREME - SAE 30**

Other oils may be used if above John Deere oils are not available, provided they meet one of the following specifications:

- SAE 15W-40 - API Service Classification CF-4 or higher.
- SAE 5W-30 - API Service Classification CC or higher.
- SAE 10W-30 - API Service Classification CF or higher.
- SAE 30 - API Service Classification CF or higher.

IMPORTANT: Avoid damage! If diesel fuel with sulfur content greater than 0.5% is used, reduce the service interval for oil and filter by 50%.

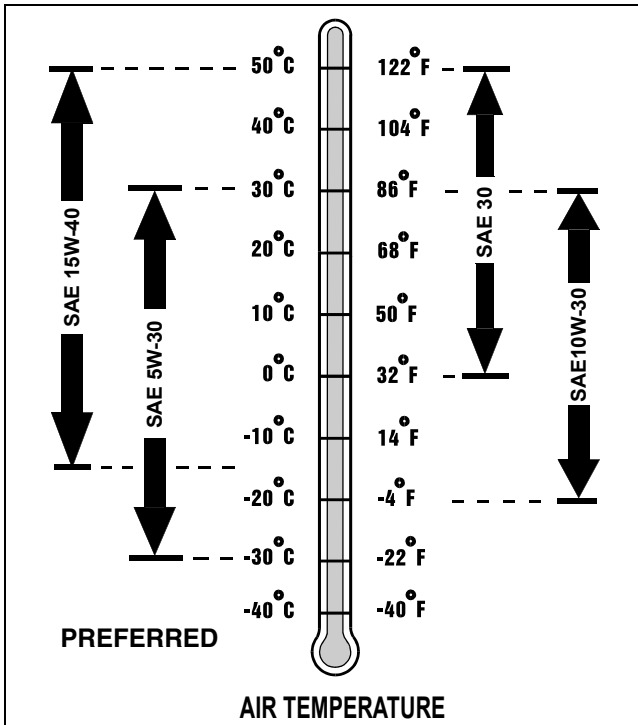

MIF (M58275)

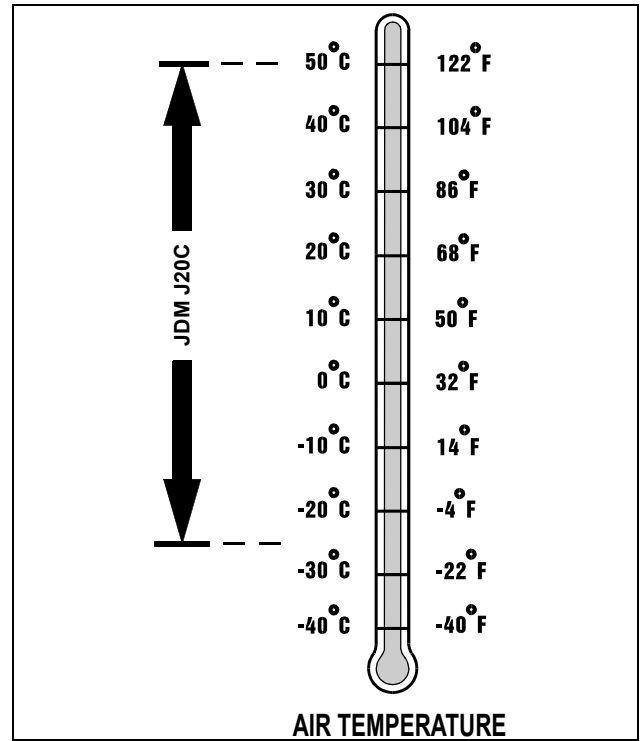

MIF (M58275)

Hydrostatic Transmission and Hydraulic Oil

Use the following oil viscosity based on the air temperature range. Operating outside of the recommended oil air temperature range may cause premature hydrostatic transmission or hydraulic system failures.

IMPORTANT: Avoid damage! DO NOT use engine oil or "Type F" (Red) Automatic Transmission Fluid in this transmission. DO NOT mix any other oils in this transmission. DO NOT use BIO-HY-GARD™ in this transmission.

The following John Deere transmission and hydraulic oil is **PREFERRED**:

- **HY-GARD™ - J20C.**

Other oils may be used if above recommended John Deere oil is not available, provided they meet the following specification:

- John Deere Standard JDM J20C.

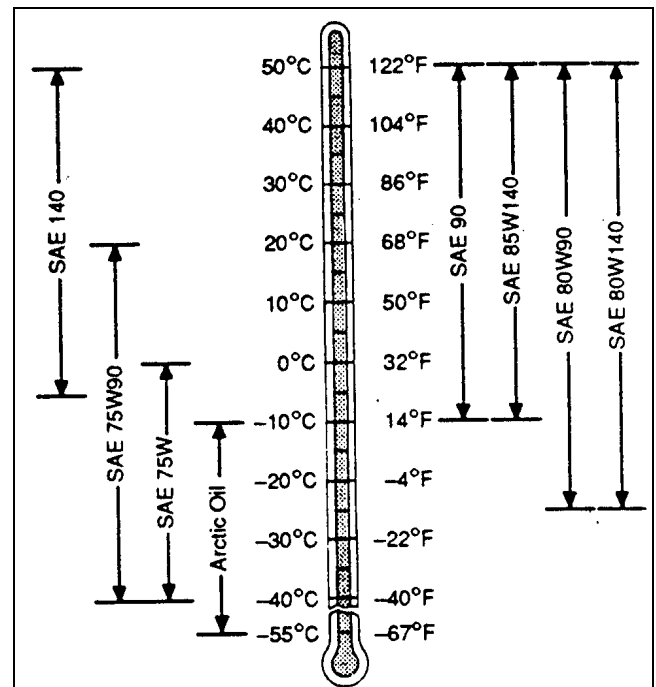

- John Deere GL-5 Gear Lubricant is recommended.
- Other oils may be used provided they meet the following specifications:
 - API Class GL-5.

SPECIFICATIONS AND INFORMATION REPAIR SPECIFICATIONS

Anti-Corrosion Grease

This anti-corrosion grease is formulated to provide the best protection against absorbing moisture, which is one of the major causes of corrosion. This grease is also superior in its resistance to separation and migration.

The following anti-corrosion grease is **PREFERRED**:

- **DuBois MPG-2® Multi-Purpose Polymer Grease - M79292.**

Other greases may be used if they meet or exceed the following specification:

- John Deere Standard JDM J13A2, NLGI Grade 1.

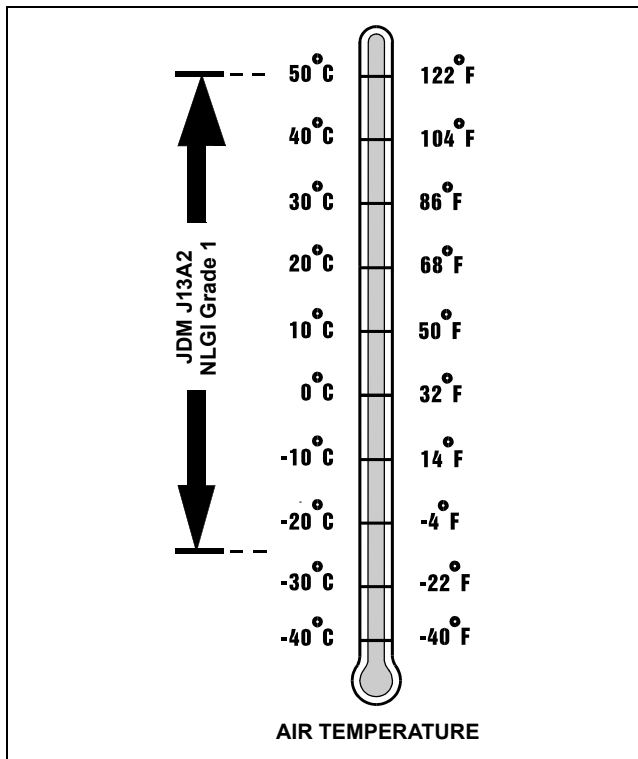

MIF (M58275)

Chassis and Roller Water Resistant Grease

This grease is specially formulated to prevent corrosion and water washout when used in a wet environment.

The following water resistant grease is **PREFERRED**:

- **Special Purpose HD Water Resistant Grease - TY24425.**

The following water resistant grease may also be used:

- **Multi-Purpose HD Lithium Complex Grease - TY24416.**

Other greases may be used if they meet or exceed the following specification:

- John Deere Standard JDM J13E4, NLGI Grade 2.

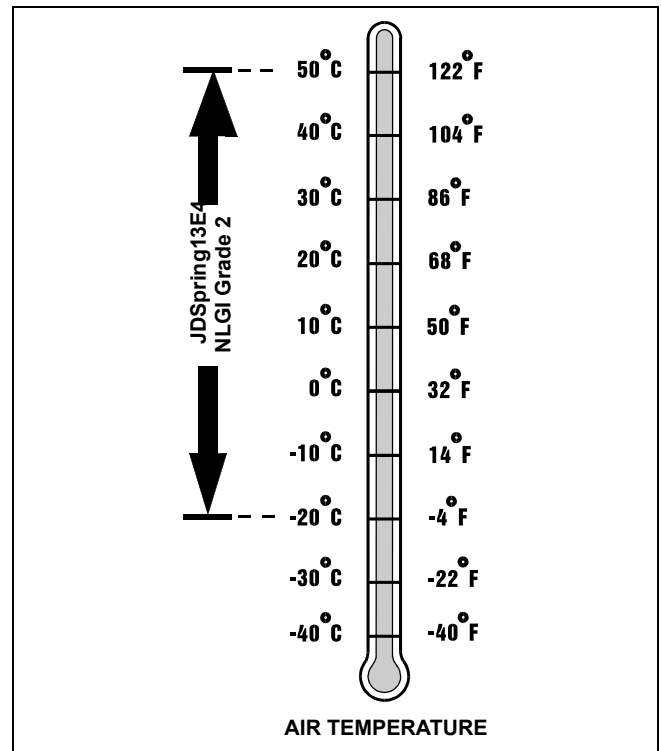

MIF (M58275)

SPECIFICATIONS AND INFORMATION REPAIR SPECIFICATIONS

Chassis and Mower Spindle Grease

This premium, multi-purpose grease is specially formulated as a high-temperature, extreme-pressure grease, especially effective in rolling contact applications.

The following water resistant grease is **PREFERRED**:

- **Multi-Purpose SD Polyurea Grease - TY6341.**

The following multi-purpose grease may also be used:

- **Multi-Purpose HD Lithium Complex Grease - TY24416.**

Other greases may be used if they meet or exceed the following specification:

- John Deere Standard JDM J13E4, NLGI Grade 2.

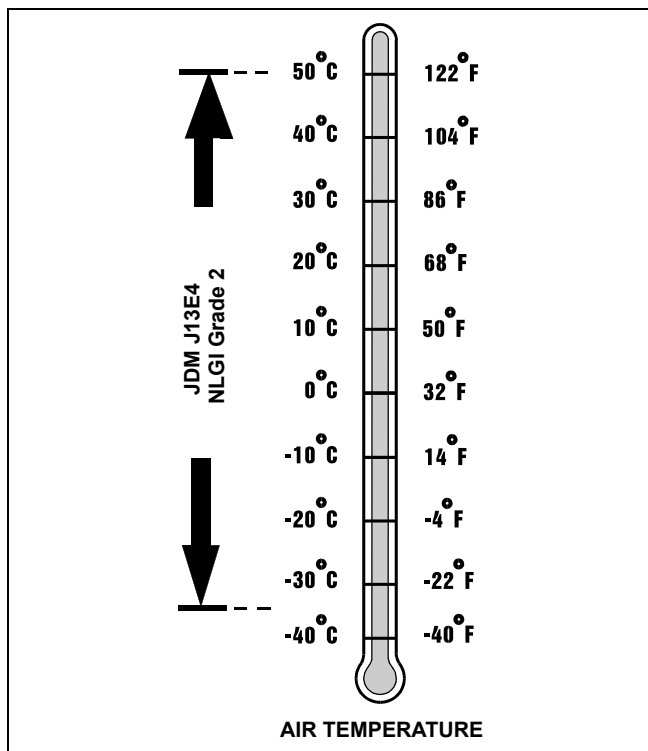

MIF (M58275)

Diesel and Gasoline Engine Coolant

The engine cooling system, when filled with a proper dilution mixture of anti-freeze and deionized or distilled water, provides year-round protection against corrosion, cylinder or liner pitting, and winter freeze protection down to -37°C (-34°F).

The following John Deere coolant is **PREFERRED**:

- **PRE-DILUTED DIESEL ENGINE ANTI-FREEZE/ SUMMER COOLANT - TY16036**

This coolant satisfies specifications for “Automobile and Light Duty Engine Service” and is safe for use in John Deere Lawn and Grounds Care/Golf and Turf Division equipment, including aluminum block gasoline engines and cooling systems.

The above preferred pre-diluted anti-freeze provides:

- adequate heat transfer
- corrosion-resistant chemicals for the cooling system
- compatibility with cooling system hose and seal material
- protection during extreme cold and extreme hot weather operations
- chemically pure water for better service life
- compliance with ASTM D4656 (JDM H24C2) specifications

If above preferred pre-diluted coolant is not available, the following John Deere concentrate is **recommended**:

- **DIESEL ENGINE ANTI-FREEZE/SUMMER COOLANT CONCENTRATE - TY16034.**

If either of above recommended engine coolants are not available use any Automobile and Light Duty Engine Service **ethylene glycol base coolant**, meeting the following specification:

- ASTM D3306 (JDM H24C1).

Read container label completely before using and follow instructions as stated.

SPECIFICATIONS AND INFORMATION GENERAL INFORMATION

IMPORTANT: Avoid damage! To prevent engine damage, DO NOT use pure anti-freeze or less than 50% anti-freeze mixture in the cooling system. DO NOT mix or add any additives/conditioners to the cooling system in Lawn and Grounds Care/Golf and Turf Division equipment. Water used to dilute engine coolant concentrate must be of high quality - clean, clear, potable water (low in chloride and hardness - Table 1) is generally acceptable. DO NOT use salt water. Deionized or distilled water is ideal to use. Coolant that is not mixed to these specified levels and water purity can cause excessive scale, sludge deposits, and increased corrosion potential.

Property	Requirements
Total Solids, Max	340 ppm (20 grns/gal)
Total Hardness, Max	170 ppm (10 grns/gal)
Chloride (as Cl), Max	40 ppm (2.5 grns/gal)
Sulfate (as SO ₄), Max	100 ppm (5.8 grns/gal)

Mix 50 percent anti-freeze concentrate with 50 percent distilled or deionized water. This mixture and the pre-diluted mixture (TY16036) will protect the cooling system down to -37°C (-34°F) and up to 108°C (226°F).

Certain geographical areas may require lower air temperature protection. See the label on your anti-freeze container or consult your John Deere dealer to obtain the latest information and recommendations.

Diesel and Gasoline Engine Coolant Drain Interval

When using **John Deere Pre-Diluted (TY16036)** Automobile and Light Duty Engine Service coolants, drain and flush the cooling system and refill with fresh coolant mixture every **36 months or 3,000 hours** of operation, whichever comes first.

When using **John Deere Concentrate (TY16034)** Automobile and Light Duty Engine Service coolants, drain and flush the cooling system and refill with fresh coolant mixture every **24 months or 2,000 hours** of operation, whichever comes first.

If above John Deere Automobile and Light Duty Engine Service coolants **are not** being used, drain, flush, and refill the cooling system according to instructions found on product container or in equipment operator's manual or technical manual.

General Information

Interlock System

It is important to understand the interlock system and how it works. Before performing the checkout procedures, become familiar with the interlock system so that an interlock function will not be mistaken for a machine problem.

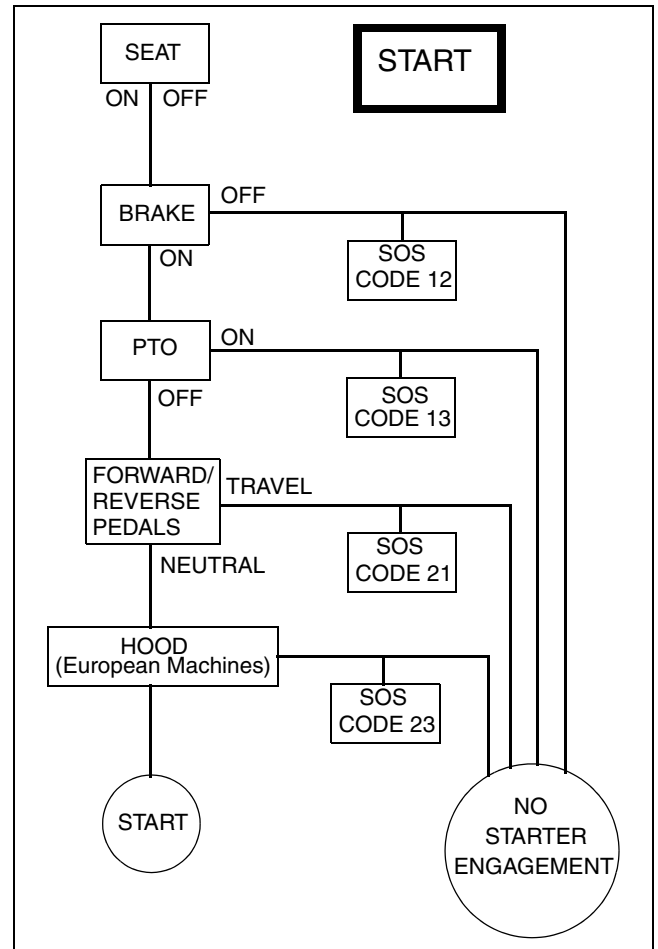

MIF

For the starting motor to engage and the engine to run, the following conditions must be met simultaneously:

- Operator on seat and/or park brake engaged.
- PTO switch in OFF position.
- Forward/reverse pedals in NEUTRAL position.
- Hood closed (European machines) or hood switch bypass in place (North American machines).

SPECIFICATIONS AND INFORMATION GENERAL INFORMATION

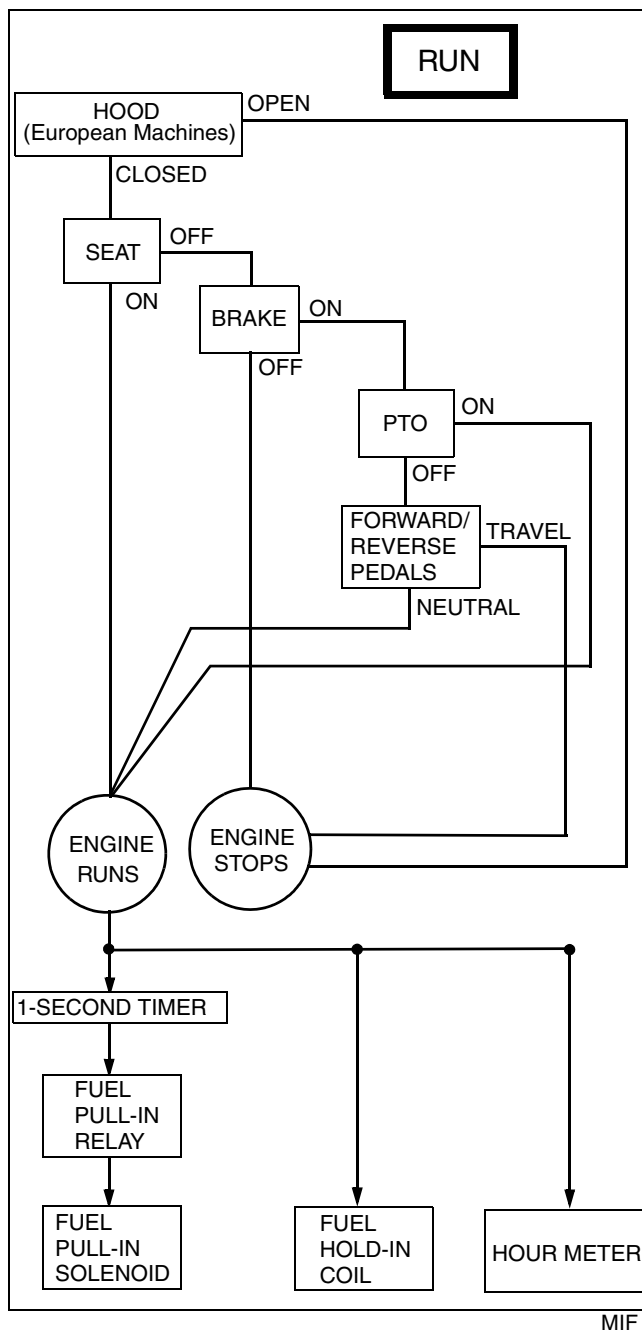

In order to mow, the following conditions must be met:

- Operator in the operator seat.
- Throttle lever moved to the FAST position.
- Cutting units lowered to the ground.
- Speed range lever in LOW position.
- Park brake not engaged.
- PTO switch in the ON position.

If the operator is mowing and the park brake is depressed, the mower decks will stop rotating.

For the engine to run, the following conditions must be met:

- Operator must be on the seat and/or the park brake must be engaged.
- Hood closed (European machines) or hood switch bypass in place (North American machines).

With the park brake not engaged and the operator rises off the seat, the engine will stop.

If the forward/reverse pedals are moved out of the NEUTRAL position and the park brake engaged, the engine will stop.

If the operator is mowing and rises off the seat, the mower decks and engine will stop.

SPECIFICATIONS AND INFORMATION PRODUCT IDENTIFICATION

Product Identification

Record Identification Numbers

Wide Area Mower 1600 Turbo

If you need to contact an Authorized Service Center for information on servicing, always provide the product model and identification numbers.

You will need to locate the identification numbers for the product. Record the information in the spaces provided below.

DATE OF PURCHASE:

DEALER NAME:

DEALER PHONE:



MX10674

PRODUCT IDENTIFICATION NUMBER (A):

ENGINE SERIAL NUMBER (B):

SPECIFICATIONS AND INFORMATION PRODUCT IDENTIFICATION

Product: John Deere 1600, 1620, and 1600 Turbo Wide Area Mower Service Repair Technical Manual

Full Download: [https://www.bobmanualstore.com/downloads/john-deere-1600-1620](https://www.bobmanualstore.com/downloads/john-deere-1600-1620-and-1600-turbo-wide-area-mower-service-repair-technical-manual/)

[0-and-1600-turbo-wide-area-mower-service-repair-technical-manual/](https://www.bobmanualstore.com/downloads/john-deere-1600-1620-and-1600-turbo-wide-area-mower-service-repair-technical-manual/)

Sample manual. Download All 688 pages at:

[https://www.bobmanualstore.com/downloads/john-deere-1600-1620-and-1600-turbo-wide-area-mower-service-repair-technical-](https://www.bobmanualstore.com/downloads/john-deere-1600-1620-and-1600-turbo-wide-area-mower-service-repair-technical-manual/)