

Product: John Deere 2653B Trim and Surrounds Mower Service Repair Technical Manual  
Full Download: <https://www.bobmanualstore.com/downloads/john-deere-2653b-trim-and-surrounds-mower-service-repair-technical-manual/>

# 2653B Tech Manual TM108019



# JOHN DEERE GOLF

Thanks, JD

Product: John Deere 2653B Trim and Surrounds Mower Service Repair Technical Manual

Full Download: <https://www.bobmanualstore.com/downloads/john-deere-2653b-trim-and-surrounds-mower-service-repair-technical-manual/>

[im-and-surrounds-mower-service-repair-technical-manual/](https://www.bobmanualstore.com/downloads/john-deere-2653b-trim-and-surrounds-mower-service-repair-technical-manual/)

Sample manual. Download All 411 pages at:

<https://www.bobmanualstore.com/downloads/john-deere-2653b-trim-and-surrounds-mower-service-repair-technical-manual/>



**JOHN DEERE**  
WORLDWIDE COMMERCIAL & CONSUMER  
EQUIPMENT DIVISION

---

**Trim and Surrounds Mower  
2653B  
(SN 030001-)**

TM108019 MARCH 2011

**TECHNICAL MANUAL**



**JOHN DEERE**

North American Version  
Litho In U.s.a.



# INTRODUCTION

---

## Manual Description

This technical manual is written for an experienced technician and contains sections that are specifically for this product. It is a part of a total product support program.

The manual is organized so that all the information on a particular system is kept together. The order of grouping is as follows:

- Table of Contents
- Specifications and Information
- Identification Numbers
- Tools and Materials
- Component Location
- Schematics and Harnesses
- Theory of Operation
- Operation and Diagnostics
- Diagnostics
- Tests and Adjustments
- Repair
- Other

**Note:** *Depending on the particular section or system being covered, not all of the above groups may be used.*

The bleed tabs for the pages of each section will align with the sections listed on this page. Page numbering is consecutive from the beginning of the Safety section through the last section.

We appreciate your input on this manual. If you find any errors or want to comment on the layout of the manual please contact us.

Safety

Specifications and Information

Engine

Electrical

Power Train

Hydraulics

Steering

Brakes

Attachments

Miscellaneous

All information, illustrations and specifications in this manual are based on the latest information at the time of publication. The right is reserved to make changes at any time without notice.

COPYRIGHT© 2011  
Deere & Co.  
John Deere Worldwide Commercial and  
Consumer Equipment Division  
All rights reserved  
Previous Editions  
COPYRIGHT© 2009



# SAFETY

## Recognize Safety Information

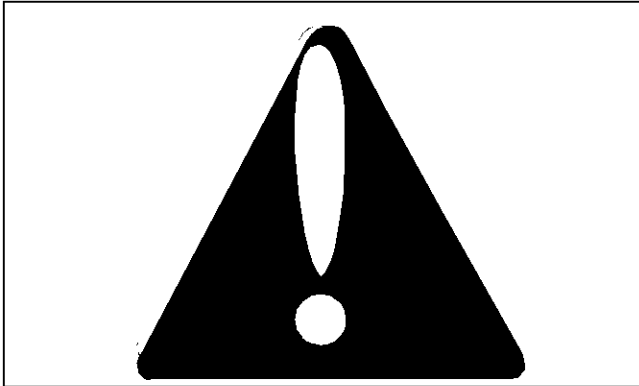

MIF

This is the safety-alert symbol. When you see this symbol on your machine or in this manual, be alert to the potential for personal injury.

Follow recommended precautions and safe servicing practices.

## Understand Signal Words

A signal word - DANGER, WARNING, or CAUTION - is used with the safety-alert symbol. DANGER identifies the most serious hazards.

DANGER or WARNING safety signs are located near specific hazards. General precautions are listed on CAUTION safety signs. CAUTION also calls attention to safety messages in this manual.

## Replace Safety Signs

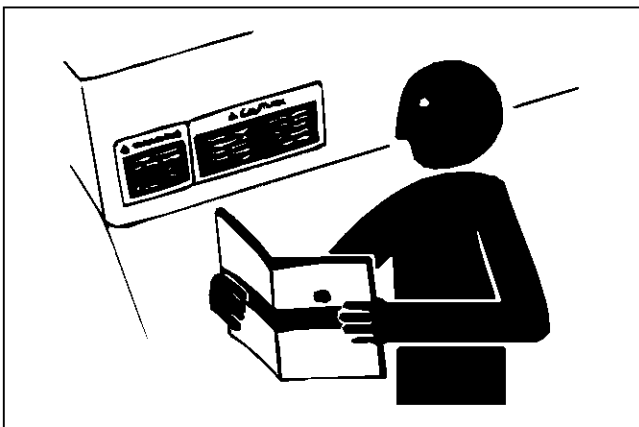

MIF

Replace missing or damaged safety signs. See the machine operator's manual for correct safety sign placement.

## Handle Fluids Safely - Avoid Fires

### Be Prepared For Emergencies

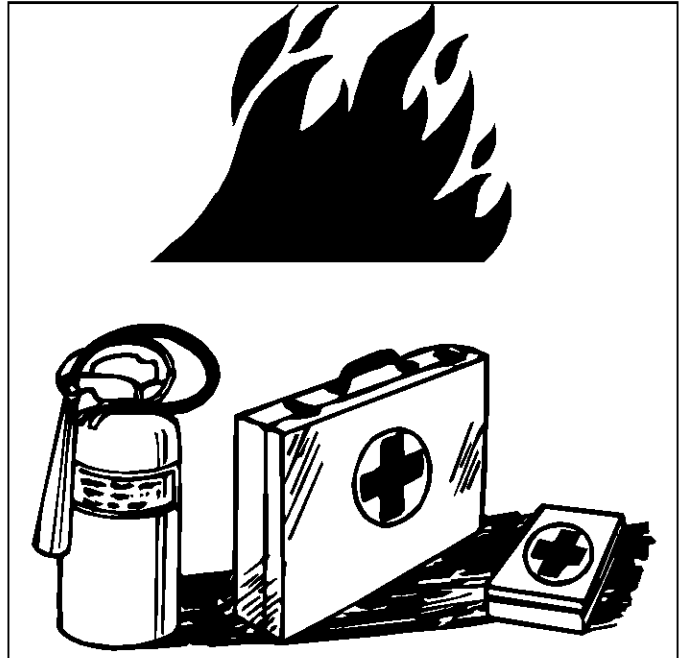

MIF

When you work around fuel, do not smoke or work near heaters or other fire hazards.

Store flammable fluids away from fire hazards. Do not incinerate or puncture pressurized containers.

Make sure machine is clean of trash, grease, and debris.

Do not store oily rags; they can ignite and burn spontaneously.

Be prepared if a fire starts.

Keep a first aid kit and fire extinguisher handy.

Keep emergency numbers for doctors, ambulance service, hospital, and fire department near your telephone.

## Use Care in Handling and Servicing Batteries

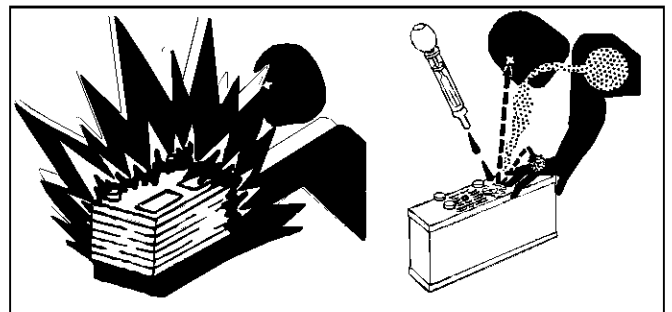

MIF

### Prevent Battery Explosions

- Keep sparks, lighted matches, and open flame away

# SAFETY

from the top of battery. Battery gas can explode.

- Never check battery charge by placing a metal object across the posts. Use a voltmeter or hydrometer.
- Do not charge a frozen battery; it may explode. Warm battery to 16°C (60°F).

## Prevent Acid Burns

- Sulfuric acid in battery electrolyte is poisonous. It is strong enough to burn skin, eat holes in clothing, and cause blindness if splashed into eyes.

## Avoid acid burns by:

1. Filling batteries in a well-ventilated area.
2. Wearing eye protection and rubber gloves.
3. Avoiding breathing fumes when electrolyte is added.
4. Avoiding spilling or dripping electrolyte.
5. Using proper jump start procedure.

## If you spill acid on yourself:

6. Flush your skin with water.
7. Apply baking soda or lime to help neutralize the acid.
8. Flush your eyes with water for 10-15 minutes.
9. Get medical attention immediately.

## If acid is swallowed:

10. Drink large amounts of water or milk.
11. Then drink milk of magnesia, beaten eggs, or vegetable oil.
12. Get medical attention immediately.

## Use Care Around High-Pressure Fluid Lines

### Avoid High-Pressure Fluids

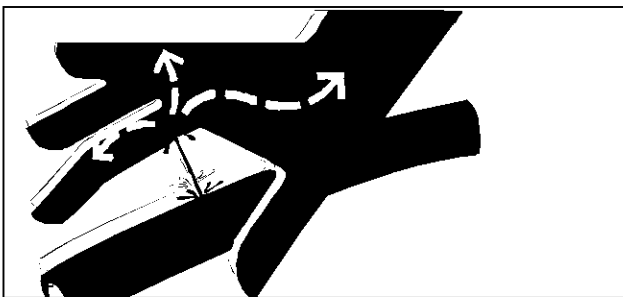

MIF

Escaping fluid under pressure can penetrate the skin causing serious injury.

Avoid injury from escaping fluid under pressure by stopping the engine and relieving pressure in the system before disconnecting or connecting hydraulic or other lines. Tighten all connections before applying pressure.

Search for leaks with a piece of cardboard. Protect hands and body from high-pressure fluids.

If an accident occurs, see a doctor immediately. Any fluid injected into the skin must be surgically removed within a few hours or gangrene may result. Doctors unfamiliar with this type of injury should reference a knowledgeable medical source. Such information is available from Deere & Company Medical Department in Moline, Illinois, U.S.A.

## Avoid Heating Near Pressurized Fluid Lines



MIF

Flammable spray can be generated by heating near pressurized fluid lines, resulting in severe burns to yourself and bystanders. Do not heat by welding, soldering, or using a torch near pressurized fluid lines or other flammable materials. Pressurized lines can be accidentally cut when heat goes beyond the immediate flame area.

## Use Safe Service Procedures

### Wear Protective Clothing

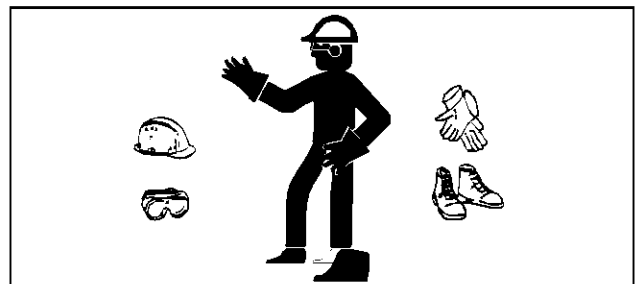

MIF

Wear close-fitting clothing and safety equipment appropriate to the job.

Prolonged exposure to loud noise can cause impairment or loss of hearing. Wear a suitable hearing protective device such as earmuffs or earplugs to protect against objectionable or uncomfortable loud noises.

Operating equipment safely requires the full attention of the operator. Do not wear radio or music headphones while operating machine.

# SAFETY

## Service Machines Safely

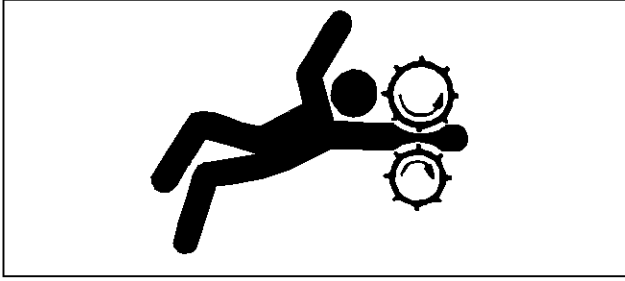

MIF

Tie long hair behind your head. Do not wear a necktie, scarf, loose clothing, or necklace when you work near machine tools or moving parts. If these items were to get caught, severe injury could result.

Remove rings and other jewelry to prevent electrical shorts and entanglement in moving parts.

### Use Proper Tools

Use tools appropriate to the work. Makeshift tools and procedures can create safety hazards. Use power tools only to loosen threaded parts and fasteners. For loosening and tightening hardware, use the correct size tools. **DO NOT** use U.S. measurement tools on metric fasteners. Avoid bodily injury caused by slipping wrenches. Use only service parts meeting John Deere specifications.

### Park Machine Safely

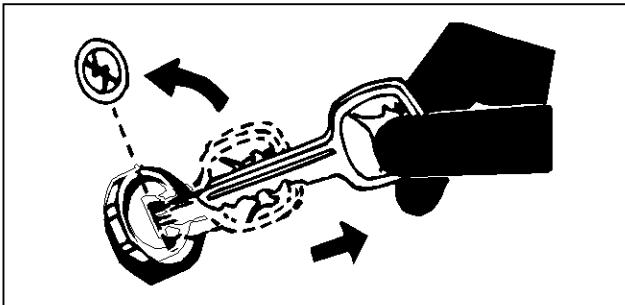

MIF

### Before working on the machine:

13. Lower all equipment to the ground.
14. Stop the engine and remove the key.
15. Disconnect the battery ground strap.
16. Hang a "DO NOT OPERATE" tag in operator station.

## Support Machine Properly and Use Proper Lifting Equipment

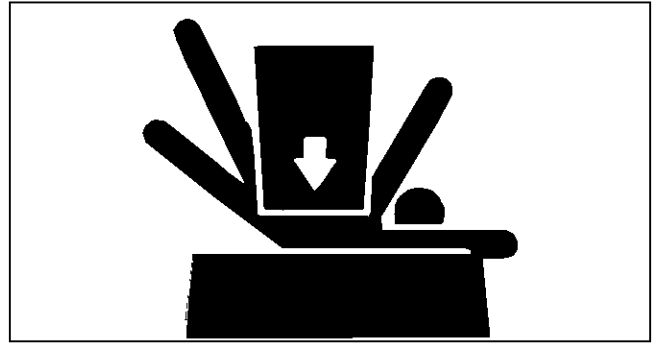

MIF

If you must work on a lifted machine or attachment, securely support the machine or attachment.

Do not support the machine on cinder blocks, hollow tiles, or props that may crumble under continuous load. Do not work under a machine that is supported solely by a jack. Follow recommended procedures in this manual.

Lifting heavy components incorrectly can cause severe injury or machine damage. Follow recommended procedure for removal and installation of components in the manual.

### Work in Clean Area

#### Before starting a job:

17. Clean work area and machine.
18. Make sure you have all necessary tools to do your job.
19. Have the right parts on hand.
20. Read all instructions thoroughly; do not attempt shortcuts.

### Using High-Pressure Washers

Directing pressurized water at electronic/electrical components or connectors, bearings, hydraulic seals, fuel injection pumps or other sensitive parts and components may cause product malfunctions. Reduce pressure and spray at a 45 to 90 degree angle.

### Illuminate Work Area Safely

Illuminate your work area adequately but safely. Use a portable safety light for working inside or under the machine. Make sure the bulb is enclosed by a wire cage. The hot filament of an accidentally broken bulb can ignite spilled fuel or oil.

# SAFETY

## Work in Ventilated Area

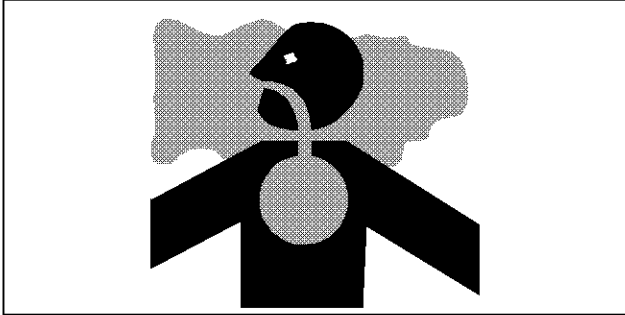

MIF

Engine exhaust fumes can cause sickness or death. If it is necessary to run an engine in an enclosed area, remove the exhaust fumes from the area with an exhaust pipe extension.

If you do not have an exhaust pipe extension, open the doors and get outside air into the area.

### **WARNING: California Proposition 65 Warning**

Diesel engine exhaust and some of its constituents are known to the State of California to cause cancer, birth defects, and other reproductive harm.

Gasoline engine exhaust from this product contains chemicals known to the State of California to cause cancer, birth defects, or other reproductive harm.

### **Remove Paint Before Welding or Heating**

Avoid potentially toxic fumes and dust. Hazardous fumes can be generated when paint is heated by welding, soldering, or using a torch. Do all work outside or in a well ventilated area. Dispose of paint and solvent properly. Remove paint before welding or heating: If you sand or grind paint, avoid breathing the dust. Wear an approved respirator. If you use solvent or paint stripper, remove stripper with soap and water before welding. Remove solvent or paint stripper containers and other flammable material from area. Allow fumes to disperse at least 15 minutes before welding or heating.

### **Avoid Harmful Asbestos Dust**

Avoid breathing dust that may be generated when handling components containing asbestos fibers. Inhaled asbestos fibers may cause lung cancer.

Components in products that may contain asbestos fibers are brake pads, brake band and lining assemblies, clutch plates, and some gaskets. The asbestos used in these components is usually found in a resin or sealed in some way. Normal handling is not hazardous as long as airborne dust containing asbestos is not generated.

Avoid creating dust. Never use compressed air for cleaning. Avoid brushing or grinding material containing asbestos. When servicing, wear an approved respirator. A special

vacuum cleaner is recommended to clean asbestos. If not available, apply a mist of oil or water on the material containing asbestos. Keep bystanders away from the area.

## Service Tires Safely

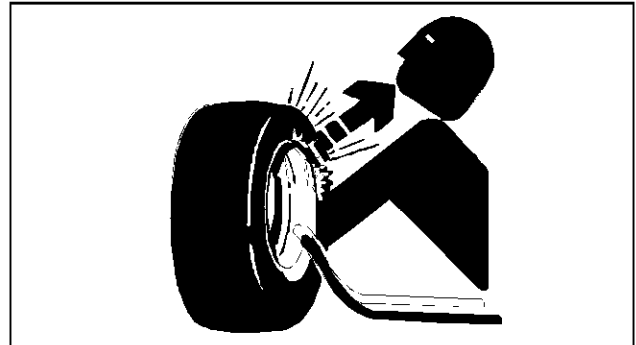

MIF

Explosive separation of a tire and rim parts can cause serious injury or death.

Do not attempt to mount a tire unless you have the proper equipment and experience to perform the job. Always maintain the correct tire pressure. Do not inflate the tires above the recommended pressure. Never weld or heat a wheel and tire assembly. The heat can cause an increase in air pressure resulting in a tire explosion. Welding can structurally weaken or deform the wheel.

When inflating tires, use a clip-on chuck and extension hose long enough to allow you to stand to one side and NOT in front of or over the tire assembly. Use a safety cage if available.

Check wheels for low pressure, cuts, bubbles, damaged rims or missing lug bolts and nuts.

## Avoid Injury from Rotating Blades and Drive Shafts

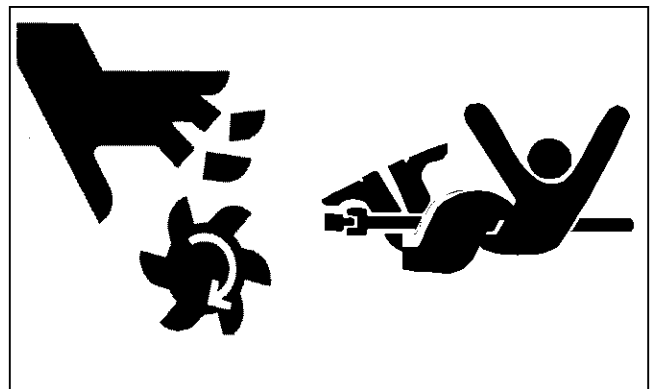

MIF

Keep hands and feet away while machine is running. Shut off power to service, lubricate or remove mower blades or drive shafts.

# SAFETY

## Service Cooling System Safety

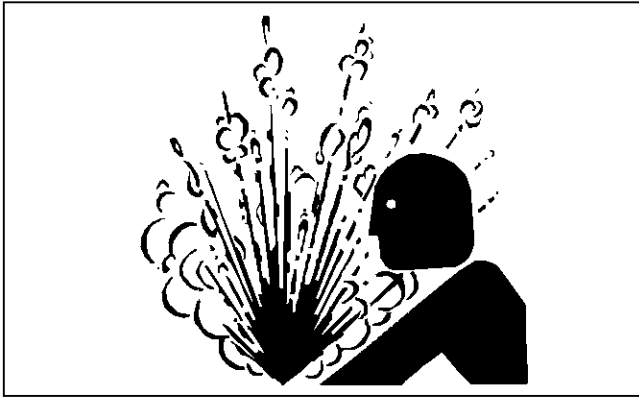

MIF

Explosive release of fluids from pressurized cooling system can cause serious burns.

Shut off machine. Only remove filler cap when cool enough to touch with bare hands. Slowly loosen the cap to first stop to relieve the pressure before removing completely.

## Handle Chemical Products Safely

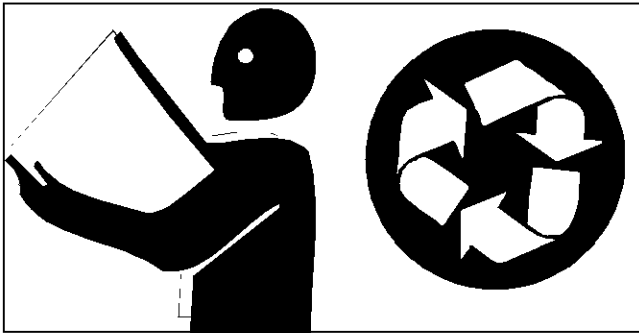

MIF

Direct exposure to hazardous chemicals can cause serious injury. Potentially hazardous chemicals used with John Deere equipment include such items as lubricants, coolants, paints, and adhesives.

A Material Safety Data Sheet (MSDS) provides specific details on chemical products: physical and health hazards, safety procedures, and emergency response techniques. Check the MSDS before you start any job using a hazardous chemical. That way you will know exactly what the risks are and how to do the job safely. Then follow procedures and recommended equipment.

## Dispose of Waste Properly

Improperly disposing of waste can threaten the environment and ecology. Potentially harmful waste used with John Deere equipment includes such items as oil, fuel, coolant, brake fluid, filters, and batteries. Use leakproof containers when draining fluids. Do not use food or beverage containers that may mislead someone into drinking from them. Do not pour waste onto the ground, down a drain, or into any water source. Inquire on the proper way to recycle or dispose of waste from your local environmental or recycling center, or from your John Deere dealer.

## LIVE WITH SAFETY



MIF

Before returning machine to customer, make sure machine is functioning properly, especially the safety systems. Install all guards and shields.

# SAFETY

---

---



# SPECIFICATIONS AND INFORMATION TABLE OF CONTENTS

---

## Table of Contents

<b>General Information.....</b>	<b>9</b>
Metric Fastener Torque Values .....	9
Metric Fastener Torque Values - Grade 7.....	10
Inch Fastener Torque Values .....	11
Face Seal Fittings with Inch Stud Ends Torque .....	12
Face Seal Fittings with Metric Stud Ends Torque .....	13
O-Ring Face Seal Fittings .....	14
O-Ring Boss Fittings .....	14
Diesel Fuel - North America .....	15
Diesel Fuel - Europe.....	15
Diesel Fuel Lubricity .....	15
Diesel Fuel Storage.....	15
4-Cycle Diesel Engine Oil - North America ..	16
4-Cycle Diesel Engine Oil - Europe.....	16
Hydrostatic Transmission and Hydraulic Oil - North America and Europe.....	17
Biodegradable Oil.....	17
Converting From HY-GARD to BIO HY-GARD.....	17
Reel Support Bearing Grease - North America .....	18
Reel Support Bearing Grease - Europe .....	18
Chassis and Roller Water Resistant Grease	18
Alternative Lubricants.....	18
Synthetic Lubricants .....	19
Lubricant Storage .....	19
Oil Filters .....	19
<b>Coolant .....</b>	<b>19</b>
Recommended Engine Coolant .....	19
<b>Identification Numbers.....</b>	<b>20</b>
Machine Identification Number Locations ....	20

# SPECIFICATIONS AND INFORMATION TABLE OF CONTENTS

---

---



# SPECIFICATIONS AND INFORMATION GENERAL INFORMATION

## General Information

## Metric Fastener Torque Values

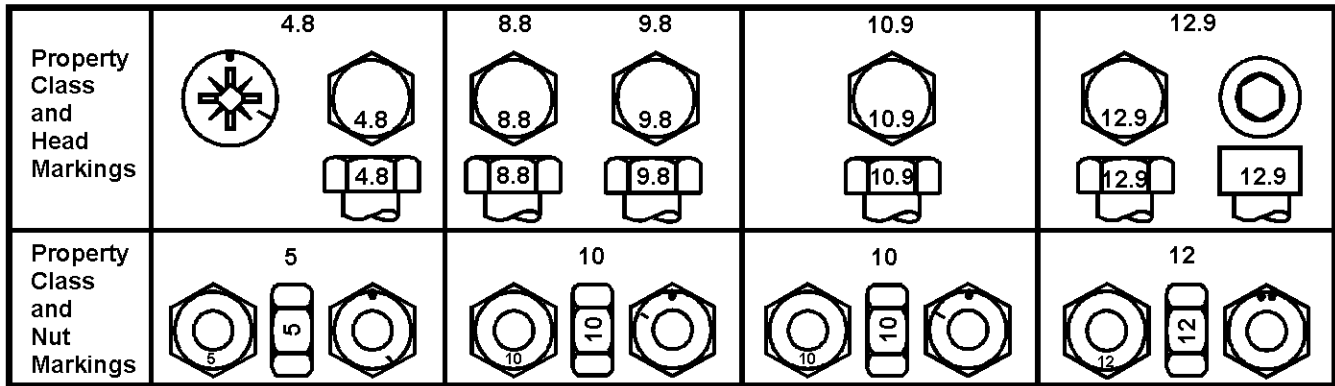

MIF (TS1163)

SIZE	Class 4.8				Class 8.8 or 9.8				Class 10.9				Class 12.9			
	Lubricated <sup>1</sup>		Dry <sup>1</sup>		Lubricated <sup>1</sup>		Dry <sup>1</sup>		Lubricated <sup>1</sup>		Dry <sup>1</sup>		Lubricated <sup>1</sup>		Dry <sup>1</sup>	
	N•m	lb-ft	N•m	lb-ft	N•m	lb-ft	N•m	lb-ft	N•m	lb-ft	N•m	lb-ft	N•m	lb-ft	N•m	lb-ft
M6	4.8	3.5	6	4.5	9	6.5	11	8.5	13	9.5	17	12	15	11.5	19	14.5
M8	12	8.5	15	11	22	16	28	20	32	24	40	30	37	28	47	35
M10	23	17	29	21	43	32	55	40	63	47	80	60	75	55	95	70
M12	40	29	50	37	75	55	95	70	110	80	140	105	130	95	165	120
M14	63	47	80	60	120	88	150	110	175	130	225	165	205	150	260	109
M16	100	73	125	92	190	140	240	175	275	200	350	225	320	240	400	300
M18	135	100	175	125	260	195	330	250	375	275	475	350	440	325	560	410
M20	190	140	240	180	375	275	475	350	530	400	675	500	625	460	800	580
M22	260	190	330	250	510	375	650	475	725	540	925	675	850	625	1075	800
M24	330	250	425	310	650	475	825	600	925	675	1150	850	1075	800	1350	1000
M27	490	360	625	450	950	700	1200	875	1350	1000	1700	1250	1600	1150	2000	1500
M30	675	490	850	625	1300	950	1650	1200	1850	1350	2300	1700	2150	1600	2700	2000
M33	900	675	1150	850	1750	1300	2200	1650	2500	1850	3150	2350	2900	2150	3700	2750
M36	1150	850	1450	1075	2250	1650	2850	2100	3200	2350	4050	3000	3750	2750	4750	3500

1. "Lubricated" means coated with a lubricant such as engine oil, or fasteners with phosphate and oil coatings. "Dry" means plain or zinc plated (yellow dichromate - Specification JDS117) without any lubrication.

DO NOT use these hand torque values if a different torque value or tightening procedure is given for a specific application. Torque values listed are for general use only and include a  $\pm 10\%$  variance factor. Check tightness of fasteners periodically. DO NOT use air powered wrenches.

Shear bolts are designed to fail under predetermined loads. Always replace shear bolts with identical grade.

Fasteners should be replaced with the same class. Make sure fastener threads are clean and that you properly start

thread engagement. This will prevent them from failing when tightening.

When bolt and nut combination fasteners are used, torque values should be applied to the NUT instead of the bolt head.

Tighten toothed or serrated-type lock nuts to the full torque value.

Reference: JDS-G200.

# SPECIFICATIONS AND INFORMATION GENERAL INFORMATION









---

## Metric Fastener Torque Values - Grade 7

Size	Steel or Gray Iron Torque		Aluminum Torque	
	N•m	lb-ft	N•m	lb-ft
M6	11	8	8	6
M8	24	18	19	14
M10	52	38	41	30
M12	88	65	70	52
M14	138	102	111	82
M16	224	165	179	132

# SPECIFICATIONS AND INFORMATION GENERAL INFORMATION

## Inch Fastener Torque Values

SAE Grade and Head Markings	1 or 2 <sup>1</sup> No Marks 	5    5.1    5.2 	8    8.2 
SAE Grade and Nut Markings	2 No Marks 	5  	8  

MIF (TS1162)

SIZE	Grade 1				Grade 2 <sup>1</sup>				Grade 5, 5.1 or 5.2				Grade 8 or 8.2			
	Lubricated <sup>2</sup>		Dry <sup>2</sup>		Lubricated <sup>2</sup>		Dry <sup>2</sup>		Lubricated <sup>2</sup>		Dry <sup>2</sup>		Lubricated <sup>2</sup>		Dry <sup>2</sup>	
	N•m	lb-ft	N•m	lb-ft	N•m	lb-ft	N•m	lb-ft	N•m	lb-ft	N•m	lb-ft	N•m	lb-ft	N•m	lb-ft
1/4	3.7	2.8	4.7	3.5	6	4.5	7.5	5.5	9.5	7	12	9	13.5	10	17	12.5
5/16	7.7	5.5	10	7	12	9	15	11	20	15	25	18	28	21	35	26
3/8	14	10	17	13	22	16	27	20	35	26	44	33	50	36	63	46
7/16	22	16	28	20	35	26	44	32	55	41	70	52	80	58	100	75
1/2	33	25	42	31	53	39	67	50	85	63	110	80	120	90	150	115
9/16	48	36	60	45	75	56	95	70	125	90	155	115	175	130	225	160
5/8	67	50	85	62	105	78	135	100	170	125	215	160	215	160	300	225
3/4	120	87	150	110	190	140	240	175	300	225	375	280	425	310	550	400
7/8	190	140	240	175	190	140	240	175	490	360	625	450	700	500	875	650
1	290	210	360	270	290	210	360	270	725	540	925	675	1050	750	1300	975
1-1/8	470	300	510	375	470	300	510	375	900	675	1150	850	1450	1075	1850	1350
1-1/4	570	425	725	530	570	425	725	530	1300	950	1650	1200	2050	1500	2600	1950
1-3/8	750	550	950	700	750	550	950	700	1700	1250	2150	1550	2700	2000	3400	2550
1-1/2	1000	725	1250	925	990	725	1250	930	2250	1650	2850	2100	3600	2650	4550	3350

1. "Grade 2" applies for hex cap screws (not hex bolts) up to 152 mm (6 in.) long. "Grade 1" applies for hex cap screws over 152 mm (6 in.) long, and for all other types of bolts and screws of any length.

2. "Lubricated" means coated with a lubricant such as engine oil, or fasteners with phosphate and oil coatings. "Dry" means plain or zinc plated (yellow dichromate - Specification JDS117) without any lubrication.

DO NOT use these hand torque values if a different torque value or tightening procedure is given for a specific application. Torque values listed are for general use only and include a ±10% variance factor. Check tightness of fasteners periodically. DO NOT use air powered wrenches.

Shear bolts are designed to fail under predetermined loads. Always replace shear bolts with identical grade.

Fasteners should be replaced with the same grade. Make sure fastener threads are clean and that you properly start

thread engagement. This will prevent them from failing when tightening.

When bolt and nut combination fasteners are used, torque values should be applied to the NUT instead of the bolt head.

Tighten toothed or serrated-type lock nuts to the full torque value.

Reference: JDS-G200.

# SPECIFICATIONS AND INFORMATION GENERAL INFORMATION

## Face Seal Fittings with Inch Stud Ends Torque

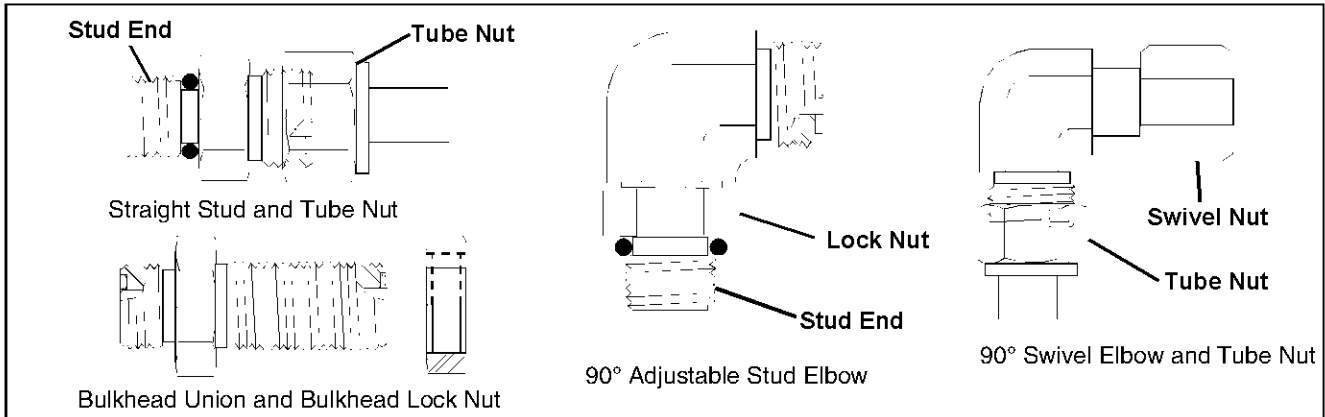

Nominal Tube OD/Hose ID				Face Seal Tube/Hose End					O-Ring Stud Ends		
Metric Tube OD	Inch Tube OD			Thread Size	Tube Nut/ Swivel Nut Torque		Bulkhead Lock Nut Torque		Thread Size	Straight Fitting or Lock Nut Torque	
mm	Dash Size	in.	mm	in.	N•m	lb-ft	N•m	lb-ft	in.	N•m	lb-ft
	-3	0.188	4.76						3/8-24	8	6
6	-4	0.250	6.35	9/16-18	16	12	12	9	7/16-20	12	9
8	-5	0.312	7.94						1/2-20	16	12
10	-6	0.375	9.52	11/16-16	24	18	24	18	9/16-18	24	18
12	-8	0.500	12.70	13/16-16	50	37	46	34	3/4-16	46	34
16	-10	0.625	15.88	1-14	69	51	62	46	7/8-14	62	46
	-12	0.750	19.05	1-3/16-12	102	75	102	75	1-1/16-12	102	75
22	-14	0.875	22.22	1-3/16-12	102	75	102	75	1-3/16-12	122	90
25	-16	1.000	25.40	1-7/16-12	142	105	142	105	1-5/16-12	142	105
32	-20	1.25	31.75	1-11/16-12	190	140	190	140	1-5/8-12	190	140
38	-24	1.50	38.10	2-12	217	160	217	160	1-7/8-12	217	160

**Note: Torque tolerance is +15%, -20%.**

# SPECIFICATIONS AND INFORMATION GENERAL INFORMATION

## Face Seal Fittings with Metric Stud Ends Torque

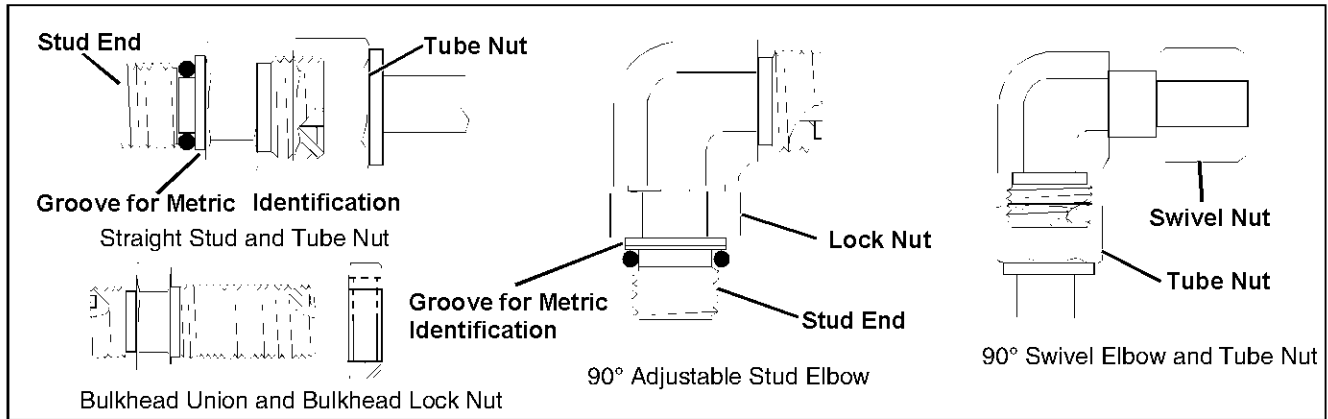

MIF

Nominal Tube OD/Hose ID				Face Seal Tube/Hose End						O-Ring Stud Ends, Straight Fitting or Lock Nut					
Metric Tube OD	Inch Tube OD			Thread Size	Hex Size	Tube Nut/ Swivel Nut Torque		Bulkhead Lock Nut Torque		Thread Size	Hex Size	Steel or Gray Iron Torque		Aluminum Torque	
	mm	Dash Size	in.			mm	in.	mm	N•m			lb-ft	N•m	lb-ft	mm
6	-4	0.250	6.35	9/16-18	17	16	12	12	9	M12x1.5	17	21	15.5	9	6.6
8	-5	0.312	7.94												
										M14x1.5	19	33	24	15	11
10	-6	0.375	9.52	11/16-16	22	24	18	24	18	M16x1.5	22	41	30	18	13
12	-8	0.500	12.70	13/16-16	24	50	37	46	34	M18x1.5	24	50	37	21	15
16	-10	0.625	15.88	1-14	30	69	51	62	46	M22x1.5	27	69	51	28	21
	-12	0.750	19.05	1-3/16-12	36	102	75	102	75	M27x2	32	102	75	46	34
22	-14	0.875	22.22	1-3/16-12	36	102	75	102	75	M30x2	36				
25	-16	1.000	25.40	1-7/16-12	41	142	105	142	105	M33x2	41	158	116	71	52
28										M38x2	46	176	130	79	58
32	-20	1.25	31.75	1-11/16-12	50	190	140	190	140	M42x2	50	190	140	85	63
38	-24	1.50	38.10	2-12	60	217	160	217	160	M48x2	55	217	160	98	72

**Note: Torque tolerance is +15%, -20%.**

## O-Ring Face Seal Fittings

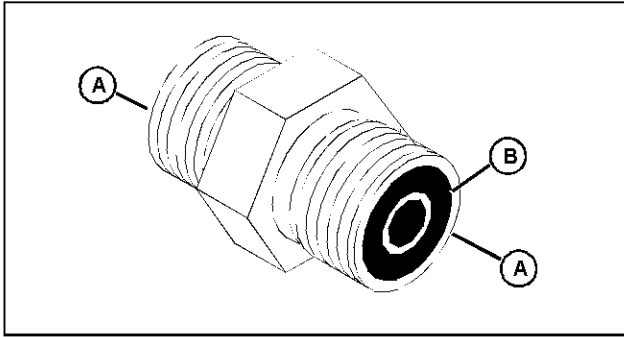

1. Inspect the fitting sealing surfaces (A). They must be free of dirt or defects.
2. Inspect the O-ring (B). It must be free of damage or defects.
3. Lubricate O-ring and install into groove using petroleum jelly to hold in place.
4. Push O-ring into the groove with plenty of petroleum jelly so O-ring is not displaced during assembly.
5. Index angle fittings and tighten by hand-pressing joint together to ensure O-ring remains in place.

**Important: Avoid Damage! DO NOT allow hoses to twist when tightening fittings. Use two wrenches to tighten hose connections: one to hold the hose, and the other to tighten the swivel fitting.**

6. Tighten fitting or nut to torque value shown on the chart per dash size stamped on the fitting.

## O-Ring Boss Fittings

1. Inspect O-ring boss seat. It must be free of dirt and defects. If repeated leaks occur, inspect for defects with a magnifying glass. Some raised defects can be removed with a slip stone.

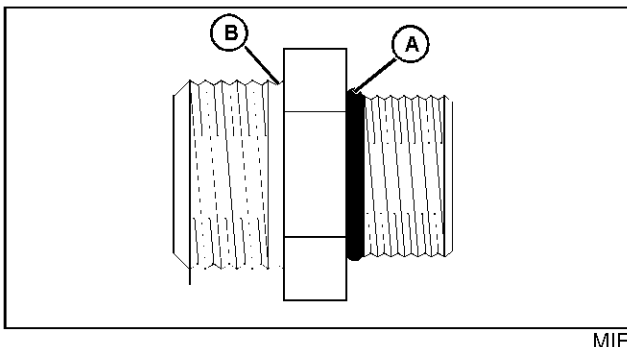

2. Put hydraulic oil or petroleum jelly on the O-ring (A). Place electrical tape over the threads to protect O-ring from nicks. Slide O-ring over the tape and into the groove (B) of fitting. Remove tape.

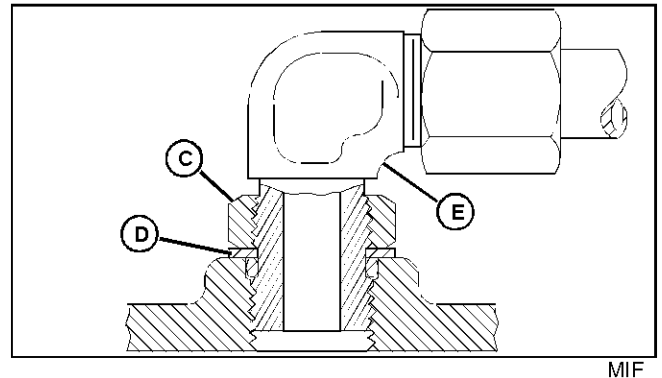

3. For angle fittings, loosen special nut (C) and push special washer (D) against threads so O-ring can be installed into the groove of fitting.
4. Turn fitting into the boss by hand until special washer or washer face (straight fitting) contacts boss face and O-ring is squeezed into its seat.
5. To position angle fittings (E), turn the fitting counter-clockwise a maximum of one turn.
6. Tighten straight fittings to torque value shown on chart. For angle fittings, tighten the special nut to value shown in the chart while holding body of fitting with a wrench.

### Straight Fitting or Special Nut Torque

Thread Size	Torque <sup>1</sup>		Number of Flats <sup>2</sup>
	N•m	lb-ft	
3/8-24 UNF	8	6	2
7/16-20 UNF	12	9	2
1/2-20 UNF	16	12	2
9/16-18 UNF	24	18	2
3/4-16 UNF	46	34	2
7/8-14 UNF	62	46	1-1/2
1-1/16-12 UN	102	75	1
1-3/16-12 UN	122	90	1
1-5/16-12 UN	142	105	3/4
1-5/8-12 UN	190	140	3/4
1-7/8-12 UN	217	160	1/2

1. Torque tolerance is  $\pm 10$  percent.

2. To be used if a torque wrench cannot be used. After tightening fitting by hand, put a mark on nut or boss, then tighten special nut or straight fitting the number of flats shown.

# SPECIFICATIONS AND INFORMATION GENERAL INFORMATION

## Diesel Fuel - North America

In general, diesel fuels are blended to satisfy the low air temperature requirements of the geographical area in which they are sold.

In North America, diesel fuel is usually specified to **ASTM D975** and sold as either **Grade 1** for cold air temperatures or **Grade 2** for warm air temperatures.

If diesel fuels being supplied in your area DO NOT meet any of the above specifications, use diesel fuels with the following equivalent properties:

- Cetane Number 40 (Min)

A cetane number greater than 50 is preferred, especially for air temperatures below -20°C (-4°F) or elevations above 1500 m (5000 ft).

- Cold Filter Plugging Point (CFPP)

The temperature at which diesel fuel begins to cloud or jell. Use diesel fuels with a CFPP which is at least 5°C (9°F) below the expected low air temperature.

- Sulfur Content of 0.05% (Max)

Diesel fuels for highway use in the United States now require sulfur content to be less than 0.05%.

If diesel fuel being used has a sulfur content greater than 0.5%, reduce the service interval for engine oil and filter by 50%.



**Caution: Avoid Injury! California Proposition 65 Warning: Diesel engine exhaust and some of its elements from this product are known to the State of California to cause cancer, birth defects, or other reproductive harm.**

Consult your local diesel fuel distributor for properties of the diesel fuel available in your area.

## Diesel Fuel - Europe

In general, diesel fuels are blended to satisfy the low air temperature requirements of the geographical area in which they are sold.

In Europe, diesel fuel is usually specified to **EN590** and sold in 5 different classes or 6 different grades.

If diesel fuels being supplied in your area DO NOT meet any of the above specifications, use diesel fuels with the following equivalent properties:

- Cetane Number 40 (Min)

A cetane number greater than 50 is preferred, especially for air temperatures below -20°C (-4°F) or elevations above 1500 m (5000 ft).

- Cold Filter Plugging Point (CFPP)

The temperature at which diesel fuel begins to cloud or jell. Use diesel fuels with a CFPP which is at least 5°C (9°F) below the expected low air temperature.

- Sulfur Content of 0.05% (Max)

If diesel fuel being used has a sulfur content greater than 0.5%, reduce the service interval for engine oil and filter by 50%.

Consult your local diesel fuel distributor for properties of the diesel fuel available in your area.

## Diesel Fuel Lubricity

Diesel fuel must have adequate lubricity to ensure proper operation and durability of fuel injection system components. Fuel lubricity should pass a minimum of 3300 gram load level as measured by the BOCLE scuffing test.

## Diesel Fuel Storage

**Important: Avoid Damage! DO NOT USE GALVANIZED CONTAINERS - diesel fuel stored in galvanized containers reacts with zinc coating in the container to form zinc flakes. If fuel contains water, a zinc gel will also form. The gel and flakes will quickly plug fuel filters and damage fuel injectors and fuel pumps.**

It is recommended that diesel fuel be stored ONLY in a clean, approved POLYETHYLENE PLASTIC container WITHOUT any metal screen or filter. This will help prevent any accidental sparks from occurring. Store fuel in an area that is well ventilated to prevent possible igniting of fumes by an open flame or spark; this includes any appliance with a pilot light.

**Important: Avoid Damage! Keep all dirt, scale, water, or other foreign material out of fuel.**

Keep fuel in a safe, protected area and in a clean, properly marked ("DIESEL FUEL") container. DO NOT use deicers to attempt to remove water from fuel. DO NOT depend on fuel filters to remove water from fuel. It is recommended that a water separator be installed in the storage tank outlet. BE SURE to properly discard unstable or contaminated diesel fuel and/or their containers when necessary.

# SPECIFICATIONS AND INFORMATION GENERAL INFORMATION

## 4-Cycle Diesel Engine Oil - North America

Use the appropriate oil viscosity based on the expected air temperature range during the period between recommended oil changes. Operating outside of these recommended oil air temperature ranges may cause premature engine failure.

The following John Deere oils are PREFERRED:

- **PLUS-50™-SAE 15W-40.**
- **TORQ-GARD SUPREME™-SAE 5W-30.**

The following John Deere oils are also recommended, based on their specified temperature range:

- **TURF-GARD™-SAE 10W-30.**
- **PLUS-4™-SAE 10W-30.**
- **TORQ-GARD SUPREME™-SAE 30.**

Other oils may be used if above John Deere oils are not available, provided they meet one of the following specifications:

- SAE 15W-40-API Service Classification CF-4 or higher.
- SAE 5W-30-API Service Classification CC or higher.
- SAE 10W-30-API Service Classification CF or higher.
- SAE 30-API Service Classification CF or higher.

**Important: Avoid Damage! If diesel fuel with sulfur content greater than 0.5% is used, reduce the service interval for oil and filter by 50%.**

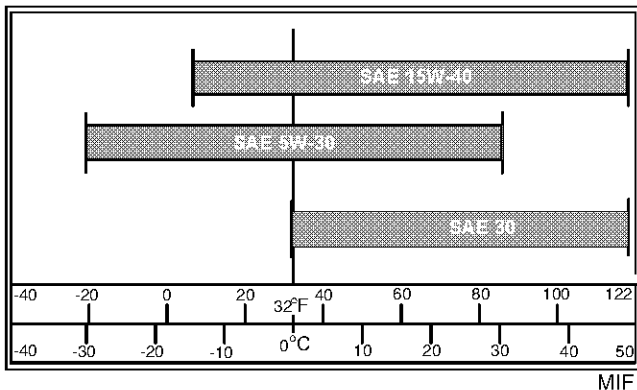

**John Deere Dealers:** You may want to cross-reference the following publications to recommend the proper oil for your customers:

- Module DX, ENOIL in JDS-G135.
- Section 530, Lubricants & Hydraulics, of the John Deere Merchandise Sales Guide.
- Lubrication Sales Manual PI7032.

## 4-Cycle Diesel Engine Oil - Europe

Use the appropriate oil viscosity based on the expected air temperature range during the period between recommended oil changes. Operating outside of these recommended oil air temperature ranges may cause premature engine failure.

The following John Deere oils are PREFERRED:

- **TORQ-GARD SUPREME™-SAE 15W-40.**
- **UNI-GARD™-SAE 15W-40.**
- **TORQ-GARD SUPREME™-SAE 5W-30.**
- **UNI-GARD™-SAE 5W-30.**

The following John Deere oils are also recommended, based on their specified temperature range:

- **TORQ-GARD SUPREME™-SAE 10W-30.**
- **UNI-GARD™-SAE 10W-30.**
- **TORQ-GARD SUPREME™-SAE 30.**
- **UNI-GARD™-SAE 30.**

Other oils may be used if above John Deere oils are not available, provided they meet the following specification:

- CCMC Specification D4 or Mercedes Benz MB228.1 or higher.

**Important: Avoid Damage! If diesel fuel with sulfur content greater the 0.5% is used, reduce the service interval for oil and filter by 50%.**

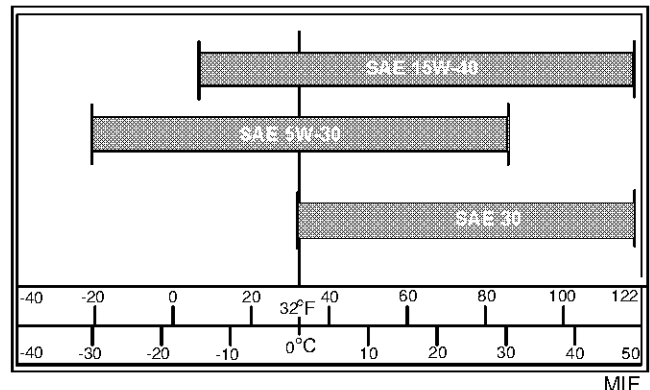

**John Deere Dealers:** You may want to cross-reference the following publications to recommend the proper oil for your customers:

- Module DX, ENOIL in JDS-G135.
- Section 530, Lubricants & Hydraulics, of the John Deere Merchandise Sales Guide.

# SPECIFICATIONS AND INFORMATION GENERAL INFORMATION

## Hydrostatic Transmission and Hydraulic Oil - North America and Europe

Use the following oil viscosity based on the air temperature range. Operating outside of the recommended oil air temperature range may cause premature hydrostatic transmission or hydraulic system failures.

**Important: Avoid Damage! DO NOT use engine oil or "Type F" (Red) Automatic Transmission Fluid in this transmission. DO NOT mix any other oils in this transmission.**

The following John Deere transmission and hydraulic oil is PREFERRED:

- **HY-GARD-JDM J20C.™**

### Low Viscosity HY-GARD™-JDM J20D.™

Use John Deere BIO HY-GARD™ oil when a biodegradable fluid is required.

Other oils may be used if above recommended John Deere oil is not available, provided they meet the following specification:

- John Deere Standard JDM J20C or J20D.

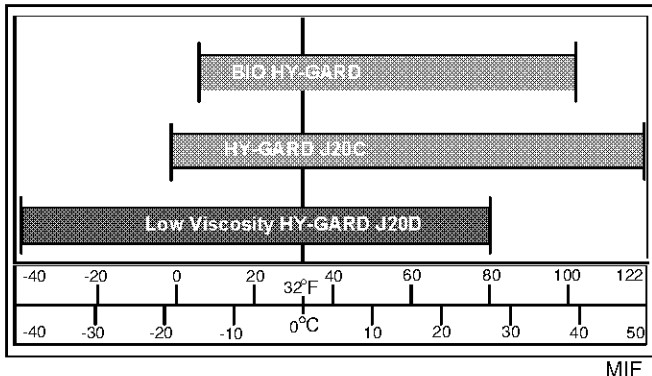

**John Deere Dealers:** You may want to cross-reference the following publications to recommend the proper oil for your customers:

- Module DX,ANTI in JDS-G135.
- Section 530, Lubricants & Hydraulics, of the John Deere Merchandise Sales Guide.
- Lubrication Sales Manual PI7032.

## Biodegradable Oil

### Application

**Important: Avoid Damage! Biodegradable oils, other than BIO HY-GARD™, are not recommended.**

When use of a biodegradable lubricant is desired or required, BIO HY-GARD is recommended. BIO HY-GARD may be used under normal mowing conditions.

DO NOT USE biodegradable lubricants in machines for the following operations:

- Any machine used for scalping procedure.
- Any verticut operation in temperatures exceeding 32°C (90°F).
- If the natural color of the fluid has become black, it is possible an overheating problem exists. Change the fluid.
- If the fluid becomes milky, water contamination may be a problem. Investigate the source of the contamination.
- Take fluid level reading when system is cold.
- Mixing of biodegradable oil and mineral oil will reduce the biodegradability of the lubricant in the machine. Mixing of HY-GARD and BIO HY-GARD will not result in performance deterioration.

### Converting From HY-GARD to BIO HY-GARD

Systems being converted from HY-GARD to BIO HY-GARD should follow the procedure listed below to obtain maximum lubricant biodegradability.

1. Park machine on a level surface.
2. Lower cutting units, stop engine, set park brake and remove key from ignition.
3. Drain hydraulic reservoir.
4. Replace hydraulic filter.
5. Fill reservoir with BIO HY-GARD to appropriate level.
6. Start engine and bring to medium idle.
7. Turn steering wheel full stroke several times and cycle cutting units several times.
8. Stop engine and check hydraulic oil level. Add BIO HY-GARD to appropriate level.
9. Operate machine under normal operating conditions for a minimum of two hours.
10. Repeat steps 1-8.
11. Follow recommended maintenance schedules.

## Reel Support Bearing Grease - North America

Use the following grease based on the air temperature range. Operating outside of the recommended grease air temperature range may cause premature failures.

The following John Deere grease is **PREFERRED**:

- **Corn Head Grease-AH80490/AN102562.**
- Cotton Picker Spindle Grease.

Other greases may be used if above preferred John Deere greases are not available, provided they meet the following specifications:

- Polyurea Grease-NLGI Grade 0.
- Calcium Complex Grease-NLGI Grade 0.

**Important: Avoid Damage! DO NOT mix any other greases (including calcium, lithium, lithium complex, and lithium 12-hydroxy based greases) with above recommended greases; they are NOT COMPATIBLE. For best results, completely remove all non-compatible grease from housing and fill with above preferred grease or one of the other greases, which are compatible with each other. DO NOT use any BIO-GREASE.**

**John Deere Dealers:** You may want to cross-reference the following publications to recommend the proper grease for your customers:

- Module DX,GREA1 in JDS-G135.
- Section 530, Lubricants & Hydraulics, of the John Deere Merchandise Sales Guide.
- Lubrication Sales Manual PI7032.

## Reel Support Bearing Grease - Europe

Use the following grease based on the air temperature range. Operating outside of the recommended grease air temperature range may cause premature failures.

The following John Deere grease is **PREFERRED**:

- **Corn Head Grease-AH80490/AN102562.**
- Cotton Picker Spindle Grease

Other greases may be used if above preferred John Deere greases are not available, provided they meet the following specifications:

- Polyurea Grease-NLGI Grade 0.
- Calcium Complex Grease-NLGI Grade 0.

**Important: Avoid Damage! DO NOT mix any other greases (including calcium, lithium, lithium complex, and lithium 12-hydroxy based greases) with above recommended greases; they are NOT COMPATIBLE. For best results, completely remove all non-compatible grease from housing and fill with above preferred grease or one of the other greases, which are compatible with each other. DO NOT use any BIO-GREASE.**

**John Deere Dealers:** You may want to cross-reference the following publications to recommend the proper grease for your customers:

- Module DX,GREA1 in JDS-G135.
- Section 530, Lubricants & Hydraulics, of the John Deere Merchandise Sales Guide.
- Lubrication Sales Manual PI7032.

## Chassis and Roller Water Resistant Grease

This grease is specially formulated to prevent corrosion and water washout when used in a wet environment.

The following water resistant grease is **PREFERRED**:

- **Special Purpose HD Water Resistant Grease - TY24425.**

The following water resistant grease may also be used:

- **Multi-Purpose HD Lithium Complex Grease - TY24416.**

Other greases may be used if they meet or exceed the following specification:

- John Deere Standard JDM J13E4, NLGI Grade 2.

## Alternative Lubricants

Conditions in certain geographical areas outside the United States and Canada may require different lubricant recommendations than the ones printed in this Technical Manual or the Operator's Manual. Consult with your John Deere Dealer, or Sales Branch, to obtain the alternative lubricant recommendations.

**Important: Avoid Damage! Use of alternative lubricants could cause reduced life of the component.**

If alternative lubricants are to be used, it is recommended that the factory fill be thoroughly removed before switching to any alternative lubricant.

# SPECIFICATIONS AND INFORMATION COOLANT

## Synthetic Lubricants

Synthetic lubricants may be used in John Deere equipment if they meet the applicable performance requirements (industry classification and/or military specification) as shown in this manual.

The recommended air temperature limits and service or lubricant change intervals should be maintained as shown in the Operator's Manual.

Avoid mixing different brands, grades, or types of oil. Oil manufacturers blend additives in their oils to meet certain specifications and performance requirements. Mixing different oils can interfere with the proper functioning of these additives and degrade lubricant performance.

## Lubricant Storage

All machines operate at top efficiency only when clean lubricants are used. Use clean storage containers to handle all lubricants. Store them in an area protected from dust, moisture, and other contamination. Store drums on their sides. Make sure all containers are properly marked as to their contents. Dispose of all old, used containers and their contents properly.

## Oil Filters

**Important: Avoid Damage! Filtration of oils is critical to proper lubrication performance. Always change filters regularly.**

The following John Deere oil filters are PREFERRED:

- **Automotive and Light Truck Engine Oil Filters.**

Most John Deere filters contain pressure relief and anti-drainback valves for better engine protection.

Other oil filters may be used if above recommended John Deere oil filters are not available, provided they meet the following specification:

- ASTB Tested in Accordance with SAE J806.

**John Deere Dealers:** You may want to cross-reference the following publications to recommend the proper oil filter for your customers:

- Module DX,FILT in JDS-G135.
- Section 540, Lubricants & Hydraulics, of the John Deere Merchandise Sales Guide.
- Lawn & Grounds Care Tune-Up Guide PI672.

## Coolant

### Recommended Engine Coolant

**Important: Avoid Damage! Using incorrect coolant mixture can cause overheating and damage to the radiator and engine:**

- **Do not operate engine with plain water.**
- **Do not exceed a 50% mixture of coolant and water.**
- **Aluminum engine blocks and radiators require approved ethylene-glycol based coolant.**

The engine cooling system is filled to provide year-round protection against corrosion and cylinder liner pitting, and winter freeze protection to -37 degrees C (-34 degrees F). If protection at lower temperatures is required, consult your John Deere dealer for recommendations.

#### The following coolants are preferred:

- John Deere COOL-GARD II™ Premix
- John Deere COOL-GARD Premix
- John Deere COOL-GARD PG Premix

John Deere COOL-GARD II Premix and John Deere COOL-GARD Premix are available in a concentration of 50% propylene glycol.

John Deere COOL-GARD PG Premix is available in a concentration of 55% propylene glycol.

#### Additional recommended coolants:

- John Deere COOL-GARD II Concentrate in a 40% to 60% mixture of concentrate with water.
- John Deere COOL-GARD Concentrate in a 40% to 60% mixture of concentrate with water.

**If the recommended coolants are unavailable, use an ethylene glycol or propylene glycol base coolant that meets the following specification:**

- ASTM D3306 prediluted (50%) coolant.
- ASTM D3306 coolant concentrate in a 40% to 60% mixture of concentrate with water.

Check container label before using to be sure it has the appropriate specifications for your machine. Use coolant with conditioner or add conditioner to coolant before using.

#### Water Quality

- Water quality is important to the performance of the cooling system. Distilled, deionized, or demineralized water is recommended with ethylene glycol base engine coolant concentrate.

# SPECIFICATIONS AND INFORMATION IDENTIFICATION NUMBERS

## Identification Numbers

### Machine Identification Number Locations

When ordering parts or submitting a warranty claim, it is **IMPORTANT** that the machine product identification number and component serial number are included.

The location of the machine identification number and component serial numbers are shown.

### Machine Identification Number

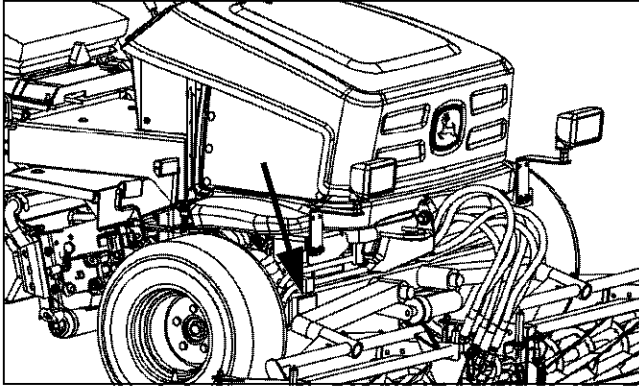

MX23409

### Diesel Engine Serial Number

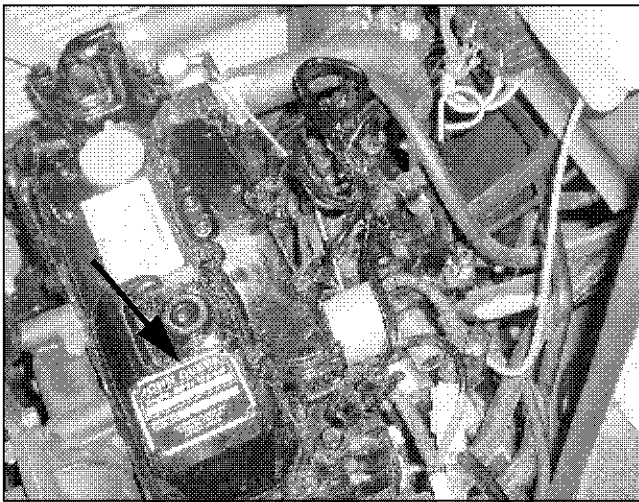

MX23404

### Hydrostatic Pump Serial Number

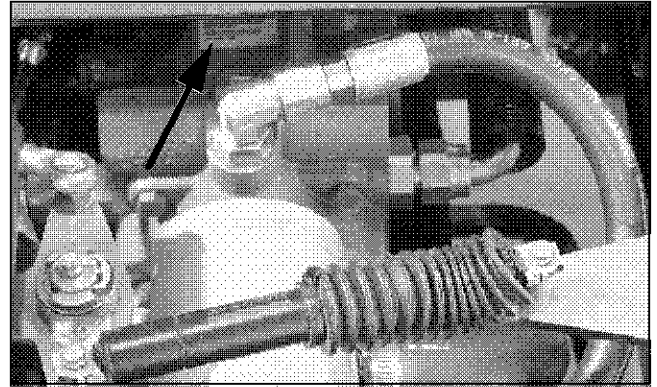

MX24081

### Cutting Unit Serial Number

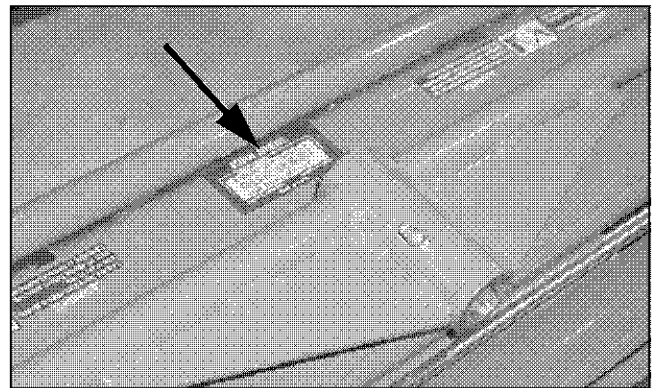

MX24308

# ENGINE - DIESEL TABLE OF CONTENTS

## Table of Contents

### Specifications .....23

General Vehicle Specifications.....	23
Test and Adjustment Specifications .....	23
Repair Specifications.....	24
Torque Specifications.....	27

### Tools and Materials .....28

Special or Required Tools .....	28
Other Material.....	30

### Theory of Operation .....31

Cooling System Operation .....	31
Lubrication System Operation .....	31
Fuel and Air System Operation .....	31

### Diesel Engine Troubleshooting.....33

Use of Dielectric Grease .....	33
Symptom: Engine Will Not Start.....	33
Symptom: Engine Starts but Does Not Continue Running - No Exhaust Smoke.....	34
Symptom: Engine Starts but Does Not Continue Running - Excess Exhaust Smoke.....	34
Symptom: Low Engine Output - Exhaust Color NORMAL .....	34
Symptom: Low Engine Output - Exhaust Color WHITE .....	35
Symptom: Low Engine Output - Exhaust Color BLACK.....	35
Symptom: Exhaust Color WHITE Under Load.....	36
Symptom: Exhaust Color BLACK Under Load.....	36
Symptom: Exhaust Temperature Too High.....	37
Engine Runs Rough - Misfiring.....	37
Symptom: Engine Runs Rough - Uneven Combustion Sound.....	37
Symptom: Engine Runs Rough - Engine Surges DURING IDLING.....	38
Symptom: Engine Runs Rough - Engine Surges UNDER LOAD .....	38
Symptom: Engine Runs Rough - Excessive Engine Vibration .....	38
Symptom: Excessive Fuel Consumption .....	39
Symptom: Excessive Oil Consumption .....	39
Symptom: Fuel Oil in Crankcase.....	39
Symptom: Coolant in Crankcase.....	39
Symptom: Low Oil Pressure.....	39

Symptom: Engine Is Overheating.....	40
Symptom: Low Engine Coolant Temperature .....	40
Symptom: Low Compression.....	40
Starting Motor Diagnostics.....	40
Symptom: Starter Does Not Rotate .....	41
Starter Rotates Slowly .....	41
Symptom: Starter Rotates but Does Not Crank 41	41

### Tests and Adjustments ..... 42

Check and Adjust Alternator Drive Belt Tension.....	42
Adjust Valve Clearance .....	42
Check Valve Lift.....	43
Test Cylinder Compression .....	44
Test Engine Oil Pressure.....	45
Leak Test Air Intake System.....	45
Test Fuel Pump Pressure .....	46
Test Fuel Transfer Pump Flow .....	47
Leak Test Fuel System .....	47
Bleed Fuel System.....	47
Adjust Slow Idle Speed.....	48
Adjust Throttle Cable .....	49
Fast Idle Speed Check .....	50
Test Fuel Injection System .....	50
Test Fuel Injection Nozzle .....	51
Injection Pump Static Timing Check.....	53
Pressure Test Cooling System .....	54
Pressure Test Radiator Cap .....	55
Test Thermostat.....	55

### Repair ..... 56

Remove and Install Alternator Drive Belt ....	56
Remove, Inspect and Install Radiator.....	57
Remove and Install Air Filter Restriction Indicator .....	57
Remove and Install Air Cleaner Assembly ..	58
Remove and Install Muffler .....	58
Remove and Install Exhaust Manifold .....	59
Remove and Install Thermostat.....	59
Remove and Install Coolant Temperature Switch .....	60
Fill Cooling System .....	61
Remove Engine .....	62
Remove and Install Subframe .....	64
Install Engine .....	64
Remove and Install Glow Plug.....	65
Remove and Install Intake Manifold (Rocker Arm Cover).....	65

# ENGINE - DIESEL TABLE OF CONTENTS

---

Remove and Install Rocker Arm Assembly .....	66
Disassemble and Assemble Rocker Arm Assembly .....	67
Remove and Install Cylinder Head .....	69
Recondition Cylinder Head .....	70
Measure Piston-to-Cylinder Head Clearance .....	75
Remove and Install Piston and Connecting Rod .....	76
Connecting Rod Side Play Check .....	82
Check Connecting Rod Bearing Clearance ..	82
Bore Engine Cylinder .....	83
Remove and Install Crankshaft Rear Oil Seal .....	85
Remove and Install Crankshaft Front Oil Seal .....	86
Crankshaft End Play Check .....	88
Crankshaft and Main Bearings .....	88
Crankshaft Main Bearing Clearance Check ..	91
Remove and Install Flywheel .....	92
Remove and Install Flywheel Housing .....	92
Remove, Inspect and Install Camshaft .....	93
Remove, Inspect, and Install Camshaft Follower .....	97
Remove and Install Timing Gear Cover .....	98
Remove and Install Idler Gear .....	99
Remove and Install Timing Gear Housing ..	101
Remove and Install Oil Pan, Crankcase Extension and Pickup Tube .....	102
Remove, Inspect and Install Oil Pump .....	103
Remove and Install Coolant Pump (Thermostat Included) .....	105
Remove and Install Fuel Filter and Water Separator Assembly .....	106
Disassemble and Assemble Fuel Filter and Water Separator .....	106
Remove and Install Fuel Injection Pump .....	107
Remove, Inspect, and Install Fuel Injection Nozzle .....	110
Remove and Install Fuel Pump .....	113
Remove and Install Starting Motor .....	114
Remove and Install 12V Alternator .....	114

# ENGINE - DIESEL SPECIFICATIONS

Product: John Deere 2653B Trim and Surrounds Mower Service Repair Technical Manual

Full Download: <https://www.bobmanualstore.com/downloads/john-deere-2653b-trim-and-surrounds-mower-service-repair-technical-manual/>

## General Vehicle Specifications

### Diesel Engine

Make	Yanmar
Model	3TNV70
Type	4-cycle diesel
Gross Output Power	14.6 kW (19.5 hp)
Bore	70 mm (2.756 in.)
Stroke	74 mm (2.913 in.)
Cylinders	3
Valves	Overhead
Displacement	0.854 L (52.1 cu in.)
Firing Order	1-3-2
Direction of Rotation	Counterclockwise (viewed from flywheel)
Combustion System	Indirect injection type
Compression Ratio	23:1
Oil Capacity with Filter (Approximate)	2.13 L (2.25 qt)
Cooling	Liquid with pump and radiator
Cooling System Capacity (Approximate)	3.5 L (3.7 qt)
Total Hydraulic System Capacity with Reservoir (Approximate)	28.4 L (7.5 gal)
Governor	Centrifugal
Slow Idle (No Load)	1400 ± 50 rpm
Fast Idle (No Load)	3150 ± 50 rpm
Fuel Filter/Water Separator	Replaceable element fuel water separator
Air Filter	Dry replaceable primary and secondary elements
Weight (Approximate)	98 kg (216 lb)

## Test and Adjustment Specifications

12V Alternator Drive Belt Deflection at 98 N (22 lb-force)	10-15 mm (0.40-0.60 in.)
Valve Clearance	0.15-0.25 mm (0.006-0.010 in.)
Cylinder Compression Pressure	3137-3344 kPa (455-485 psi)
Cylinder Compression Pressure (Minimum)	2448-2654 kPa (355-385 psi)
Pressure Difference between Cylinders (Maximum)	200-296 kPa (29-43 psi)
Engine Oil Pressure @ 3150 RPM	290-441 kPa (42-64 psi)
Engine Oil Pressure @ 1400 RPM	60 kPa (9 psi)
Fuel Transfer Pump Pressure (Minimum)	25 kPa (4.3 psi)
Fuel Transfer Pump Flow Volume (Min in One Minute)	400 mL (13.5 oz.)
Slow Idle Speed	1400 ± 50 rpm
Fast Idle Speed	3150 ± 50 rpm

### Fuel Injection Nozzle

New Nozzle Opening Pressure (5 Hours or Less Usage)	12 800-13 800 kPa (1856.5-2001.5 psi)
Used Nozzle Opening Pressure	12 300-13 300 kPa (1784-1929 psi)

Sample manual. Download All 411 pages at:

<https://www.bobmanualstore.com/downloads/john-deere-2653b-trim-and-surrounds-mower-service-repair-technical-manual/>  
Engine - Diesel Specifications - 23