

Product: John Deere 1200 Bunker and Field Rake Service Repair Technical Manual
Full Download: <https://www.bobmanualstore.com/downloads/john-deere-1200-bunker-and-field-rake-service-repair-technical-manual/>

1200 Bunker and Field Rake

For complete service information also see:

John Deere K Series Air Cooled
Engines CTM5

Sample Manual. Download All 476 pages at:
<https://www.bobmanualstore.com/downloads/john-deere-1200-bunker-and-field-rake-service-repair-technical-manual/>

TM1525 (27SEP91)

LITHO IN U.S.A.
ENGLISH

Introduction

Product: John Deere 1200 Bunker and Field Rake Service Repair Technical Manual

Full Download: <https://www.bobmanualstore.com/downloads/john-deere-1200-bun-ker-and-field-rake-service-repair-technical-manual/>

FOREWORD

This manual is written for an experienced technician. Essential tools required in performing certain service work are identified in this manual and are recommended for use.

Live with safety: Read the safety messages in the introduction of this manual and the cautions presented throughout the text of the manual.

N This is the safety-alert symbol. When you see this symbol on the machine or in this manual, be alert to the potential for personal injury.

Technical manuals are divided in two parts: repair and diagnostics. Repair sections tell how to repair the components. Diagnostic sections help you identify the majority of routine failures quickly.

Information is organized in groups for the various components requiring service instruction. At the beginning of each group are summary listings of all applicable essential tools, other materials needed to do the job and service parts kits.

Section 10, Group 15—Repair Specifications, consist of all applicable specifications, near tolerances and specific torque values for various components on each individual machine.

Binders, binder labels, and tab sets can be ordered by John Deere dealers direct from the John Deere Distribution Service Center.

This manual is part of a total product support program.

FOS MANUALS—REFERENCE

TECHNICAL MANUALS—MACHINE SERVICE

COMPONENT MANUALS—COMPONENT SERVICE

Fundamentals of Service (FOS) Manuals cover basic theory of operation, fundamentals of troubleshooting, general maintenance, and basic type of failures and their causes. FOS Manuals are for training new personnel and for reference by experienced technicians.

Technical Manuals are concise guides for specific machines. Technical manuals are on-the-job guides containing only the vital information needed for diagnosis, analysis, testing, and repair.

Component Technical Manuals are concise service guides for specific components. Component technical manuals are written as stand-alone manuals covering multiple machine applications.

Sample manual. Download All 476 pages at:

MX, TMIFC, A -19-25MAR91

<https://www.bobmanualstore.com/downloads/john-deere-1200-bunker-and-field-rake-service-repair-technical-manual/>

TM1625 (2/95 EP9)

1200 Bunker and Field Rake

171095

Contents

SECTION 10—GENERAL INFORMATION

- Group 05—Safety
- Group 10—General Specifications
- Group 15—Repair Specifications
- Group 20—Fuel and Lubricants
- Group 25—Serial Number Locations
- Group 30—Features and Attachments

SECTION 20—ENGINE REPAIR

- Group 05—Engine—FE290
- Group 10—Muffler

SECTION 30—FUEL AND AIR REPAIR

- Group 05—Fuel System
- Group 10—Air System

SECTION 40—ELECTRICAL REPAIR

- Group 05—Battery and Cables
- Group 10—Electrical System Components
- Group 15—Wiring Harness

SECTION 50—POWER TRAIN REPAIR

- Group 05—Wet Reduction Clutch
- Group 10—Drive Belt and Clutches
- Group 15—Control Linkage
- Group 20—Transaxle
- Group 25—Drive Axles

SECTION 60—STEERING AND BRAKE REPAIR

- Group 05—Steering System Repair
- Group 10—Brake Repair

SECTION 70—HYDRAULIC REPAIR

- Group 05—Lift System Repair

SECTION 80—MISCELLANEOUS REPAIR

- Group 05—Hoods and Panels
- Group 10—Wheels and Bearings
- Group 15—Rake Assembly
- Group 20—40 Inch Front Blade Assembly
- Group 25—Cultivator Assembly

SECTION 210—TEST & ADJUSTMENT SPECIFICATIONS/OPERATIONAL CHECKOUT PROCEDURES

- Group 05—Test & Adjustment Specifications
- Group 10—Operational Checkout Procedures

SECTION 220—ENGINE OPERATION, TESTS & ADJUSTMENTS

- Group 05—Component Location
- Group 10—Theory of Operation
- Group 15—Diagnosis, Tests & Adjustments

SECTION 230—FUEL/AIR OPERATION, TESTS & ADJUSTMENTS

- Group 05—Component Location
- Group 10—Theory of Operation
- Group 15—Diagnosis, Tests & Adjustments

SECTION 240—ELECTRICAL OPERATION, TESTS & ADJUSTMENTS

- Group 05—Component Location
- Group 10—Theory of Operation
- Group 15—Diagnosis, Tests & Adjustments
- Group 20—Wiring Schematics

SECTION 250—POWER TRAIN OPERATION, TESTS & ADJUSTMENTS

- Group 05—Component Location
- Group 10—Theory of Operation
- Group 15—Diagnosis, Tests & Adjustments

SECTION 260—STEERING & BRAKES OPERATION, TESTS & ADJUSTMENTS

- Group 05—Component Location
- Group 10—Theory of Operation
- Group 15—Diagnosis, Tests & Adjustments

SECTION 270—HYDRAULIC SYSTEM OPERATION, TESTS & ADJUSTMENTS

- Group 05—Component Location
- Group 10—Theory of Operation
- Group 15—Diagnosis, Tests & Adjustments

Continued on next page

All information, illustrations and specifications in this manual are based on the latest information available at the time of publication. The right is reserved to make changes at any time without notice.

TM1525-19-27SEP91

COPYRIGHT© 1991
DEERE & COMPANY
Moline, Illinois
All rights reserved
A John Deere ILLUSTRATION® Manual

Group 20—Hydraulic Schematic

10

Index

20

30

40

50

60

70

80

210

220

230

240

250

260

270

INDX

230

240

250

260

270

INDX

Section 10

GENERAL INFORMATION

Contents

Page

Group 05—Safety 10-05-1

Group 10—General Specifications

Specifications

Machine 10-10-1

Attachment 10-10-2

Group 15—Repair Specifications

Specifications

Repair 10-15-1

Tune-Up 10-15-5

Tune-Up Adjustments 10-15-6

Service Recommendations For O-Ring

Boss Fittings 10-15-7

Metric Cap Screw Torque Values 10-15-8

Inch Cap Screw Torque Values 10-15-9

Group 20—Fuel and Lubricants

Fuel 10-20-1

Storing Fuel 10-20-1

Gasoline Engine/Wet Clutch Oil 10-20-2

Transaxle Oil 10-20-2

Extreme Pressure or Multipurpose

Grease 10-20-3

Lubricant Storage 10-20-3

Alternative Lubricants 10-20-3

Group 25—Serial Number Locations

Serial Numbers 10-25-1

Product Identification Number Location . . 10-25-1

Serial Number Location

Engine 10-25-1

Transaxle 10-25-1

Hydraulic Pump 10-25-2

Group 30—Features and Attachments

Features and Attachments 10-30-1

Features

Machine 10-30-1

Engine 10-30-2

Power Train 10-30-3

Electrical System 10-30-4

Rake 10-30-4

Optional Attachments and Kits 10-30-5

RECOGNIZE SAFETY INFORMATION

This is the safety-alert symbol. When you see this symbol on your machine or in this manual, be alert to the potential for personal injury.

Follow recommended precautions and safe operating practices.

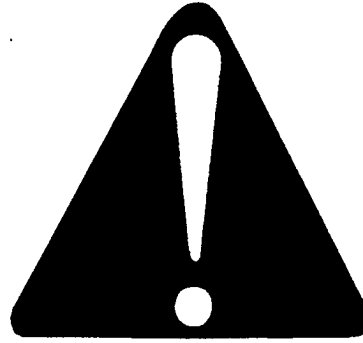

DX,ALERT -19-04JUN90

T81389 -UN-07DEC88

UNDERSTAND SIGNAL WORDS

A signal word—DANGER, WARNING, or CAUTION—is used with the safety-alert symbol. DANGER identifies the most serious hazards.

DANGER or WARNING safety signs are located near specific hazards. General precautions are listed on CAUTION safety signs. CAUTION also calls attention to safety messages in this manual.



DX,SIGNAL -19-04JUN90

TS187 -19-30SEP88

FOLLOW SAFETY INSTRUCTIONS

Carefully read all safety messages in this manual and on your machine safety signs. Keep safety signs in good condition. Replace missing or damaged safety signs. Be sure new equipment components and repair parts include the current safety signs. Replacement safety signs are available from your John Deere dealer.

Learn how to operate the machine and how to use controls properly. Do not let anyone operate without instruction.

Keep your machine in proper working condition. Unauthorized modifications to the machine may impair the function and/or safety and affect machine life.

If you do not understand any part of this manual and need assistance, contact your John Deere dealer.



DX,READ -19-04JUN90

TS201 -UN-23AUG88

10
05
2

HANDLE FLUIDS SAFELY—AVOID FIRES

When you work around fuel, do not smoke or work near heaters or other fire hazards.

Store flammable fluids away from fire hazards. Do not incinerate or puncture pressurized containers.

Make sure machine is clean of trash, grease, and debris.

Do not store oily rags; they can ignite and burn spontaneously.



DX,FLAME -19-04JUN90

-UN-23AUG88
TS227

PREVENT BATTERY EXPLOSIONS

Keep sparks, lighted matches, and open flame away from the top of battery. Battery gas can explode.

Never check battery charge by placing a metal object across the posts. Use a volt-meter or hydrometer.

Do not charge a frozen battery; it may explode. Warm battery to 16°C (60°F).



DX,SPARKS -19-04JUN90

-UN-23AUG88
TS204

PREPARE FOR EMERGENCIES

Be prepared if a fire starts.

Keep a first aid kit and fire extinguisher handy.

Keep emergency numbers for doctors, ambulance service, hospital, and fire department near your telephone.

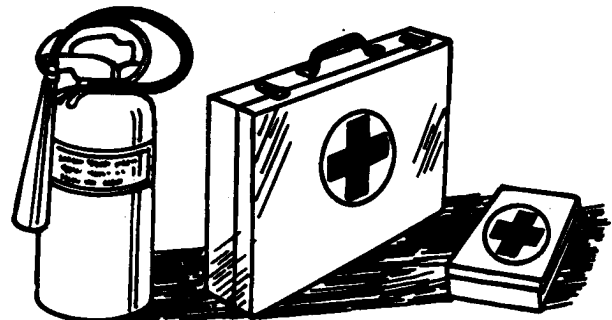

DX,FIRE2 -19-04JUN90

-UN-23AUG88
TS291

PREVENT ACID BURNS

Sulfuric acid in battery electrolyte is poisonous. It is strong enough to burn skin, eat holes in clothing, and cause blindness if splashed into eyes.

Avoid the hazard by:

1. Filling batteries in a well-ventilated area.
2. Wearing eye protection and rubber gloves.
3. Avoiding breathing fumes when electrolyte is added.
4. Avoiding spilling or dripping electrolyte.
5. Use proper jump start procedure.

If you spill acid on yourself:

1. Flush your skin with water.
2. Apply baking soda or lime to help neutralize the acid.
3. Flush your eyes with water for 10—15 minutes. Get medical attention immediately.

If acid is swallowed:

1. Drink large amounts of water or milk.
2. Then drink milk of magnesia, beaten eggs, or vegetable oil.
3. Get medical attention immediately.

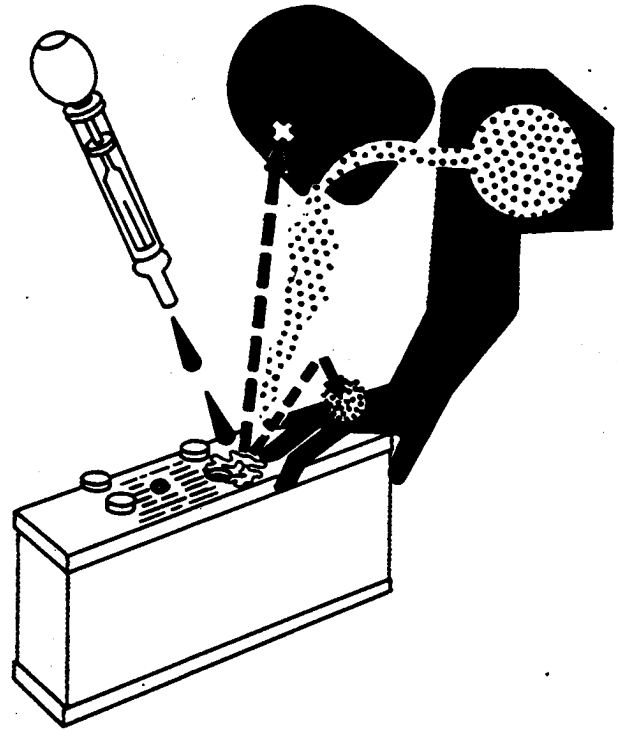

10
3 95

-UN-23AUG88

TS203

DX,POISON -19-04JUN90

10
05
4

AVOID HIGH-PRESSURE FLUIDS

Escaping fluid under pressure can penetrate the skin causing serious injury.

Avoid the hazard by relieving pressure before disconnecting hydraulic or other lines. Tighten all connections before applying pressure.

Search for leaks with a piece of cardboard. Protect hands and body from high pressure fluids.

If an accident occurs, see a doctor immediately. Any fluid injected into the skin must be surgically removed within a few hours or gangrene may result. Doctors unfamiliar with this type of injury should reference a knowledgeable medical source. Such information is available from Deere & Company Medical Department in Moline, Illinois, U.S.A.

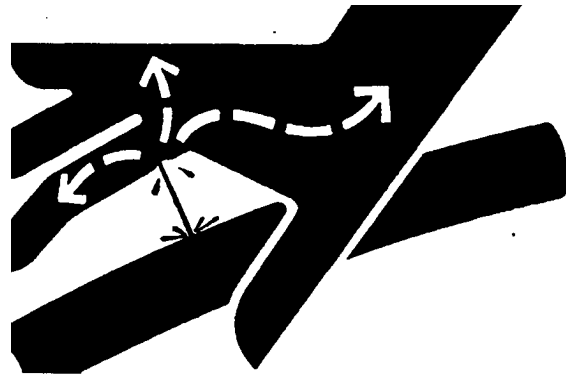

-UN-23AUG88

X9811

DX,FLUID -19-09AUG91

PARK MACHINE SAFELY

Before working on the machine:

- Lower all equipment to the ground.
- Stop the engine and remove the key.
- Disconnect the battery ground strap.
- Hang a "DO NOT OPERATE" tag in operator station.

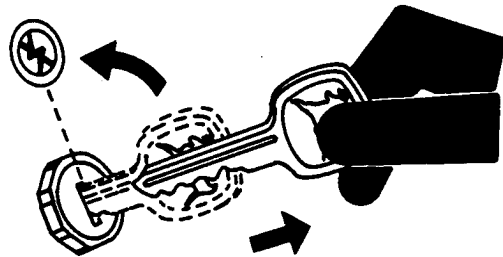

-UN-24MAY89

TS230

DX,PARK -19-04JUN90

SUPPORT MACHINE PROPERLY

Always lower the attachment or implement to the ground before you work on the machine. If you must work on a lifted machine or attachment, securely support the machine or attachment.

Do not support the machine on cinder blocks, hollow tiles, or props that may crumble under continuous load. Do not work under a machine that is supported solely by a jack. Follow recommended procedures in this manual.

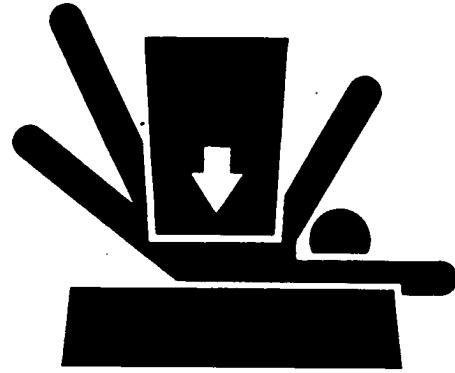

DX,LOWER -19-04JUN90

51910
-UN-23AUG88
TS229

WEAR PROTECTIVE CLOTHING

Wear close fitting clothing and safety equipment appropriate to the job.

Prolonged exposure to loud noise can cause impairment or loss of hearing.

Wear a suitable hearing protective device such as earmuffs or earplugs to protect against objectionable or uncomfortable loud noises.

Operating equipment safely requires the full attention of the operator. Do not wear radio or music headphones while operating machine.

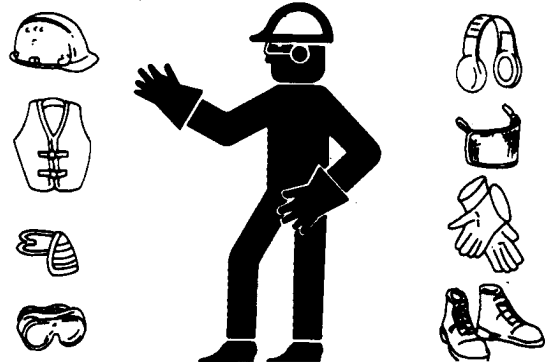

DX,WEAR -19-10SEP90

-UN-23AUG88
TS206

SERVICE MACHINES SAFELY

Tie long hair behind your head. Do not wear a necktie, scarf, loose clothing, or necklace when you work near machine tools or moving parts. If these items were to get caught, severe injury could result.

Remove rings and other jewelry to prevent electrical shorts and entanglement in moving parts.

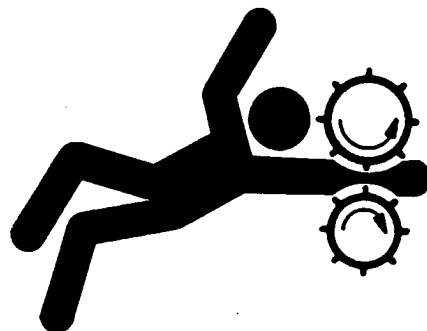

DX,LOOSE -19-04JUN90

-UN-23AUG88
TS228

WORK IN VENTILATED AREA

Engine exhaust fumes can cause sickness or death. If it is necessary to run an engine in an enclosed area, remove the exhaust fumes from the area with an exhaust pipe extension.

If you do not have an exhaust pipe extension, open the doors and get outside air into the area.

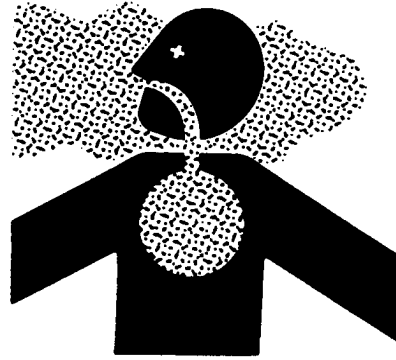

DX,AIR -19-04JUN90

TS220 -UN-23AUG88

WORK IN CLEAN AREA

Before starting a job:

- Clean work area and machine.
- Make sure you have all necessary tools to do your job.
- Have the right parts on hand.
- Read all instructions thoroughly; do not attempt shortcuts.

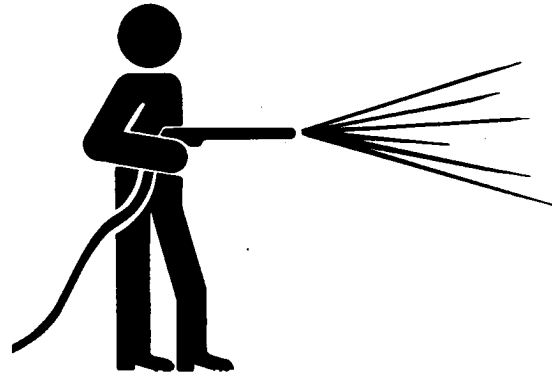

DX,CLEAN -19-04JUN90

T6642EJ -UN-18OCT88

ILLUMINATE WORK AREA SAFELY

Illuminate your work area adequately but safely. Use a portable safety light for working inside or under the machine. Make sure the bulb is enclosed by a wire cage. The hot filament of an accidentally broken bulb can ignite spilled fuel or oil.



DX,LIGHT -19-04JUN90

TS223 -UN-23AUG88

REMOVE PAINT BEFORE WELDING OR HEATING

Avoid potentially toxic fumes and dust.

Hazardous fumes can be generated when paint is heated by welding, soldering, or using a torch.

Do all work outside or in a well ventilated area. Dispose of paint and solvent properly.

Remove paint before welding or heating:

- If you sand or grind paint, avoid breathing the dust. Wear an approved respirator.
- If you use solvent or paint stripper, remove stripper with soap and water before welding. Remove solvent or paint stripper containers and other flammable material from area. Allow fumes to disperse at least 15 minutes before welding or heating.



DX,PAINT -19-04JUN90

10
05
7
-UN-23AUG88
TS220

AVOID HEATING NEAR PRESSURIZED FLUID LINES

Flammable spray can be generated by heating near pressurized fluid lines, resulting in severe burns to yourself and bystanders. Do not heat by welding, soldering, or using a torch near pressurized fluid lines or other flammable materials. Pressurized lines can be accidentally cut when heat goes beyond the immediate flame area.



DX,TORCH -19-05OCT90

-UN-15MAY90
TS953

REPLACE SAFETY SIGNS

Replace missing or damaged safety signs. See the machine operator's manual for correct safety sign placement.



DX,SIGNS1 -19-04JUN90

-UN-23AUG88
TS201

10
05
8

USE PROPER LIFTING EQUIPMENT

Lifting heavy components incorrectly can cause severe injury or machine damage.

Follow recommended procedure for removal and installation of components in the manual.

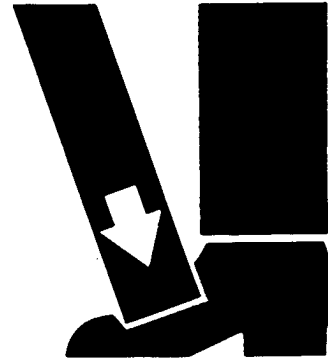

DX,LIFT -19-04JUN90

TS226 -UN-23AUG88

SERVICE TIRES SAFELY

Explosive separation of a tire and rim parts can cause serious injury or death.

Do not attempt to mount a tire unless you have the proper equipment and experience to perform the job.

Always maintain the correct tire pressure. Do not inflate the tires above the recommended pressure. Never weld or heat a wheel and tire assembly. The heat can cause an increase in air pressure resulting in a tire explosion. Welding can structurally weaken or deform the wheel.

When inflating tires, use a clip-on chuck and extension hose long enough to allow you to stand to one side and NOT in front of or over the tire assembly. Use a safety cage if available.

Check wheels for low pressure, cuts, bubbles, damaged rims or missing lug bolts and nuts.



DX,TIRECP -19-24AUG90

TS952 -UN-12APR90

AVOID HARMFUL ASBESTOS DUST

Avoid breathing dust that may be generated when handling components containing asbestos fibers. Inhaled asbestos fibers may cause lung cancer.

Components in products that may contain asbestos fibers are brake pads, brake band and lining assemblies, clutch plates, and some gaskets. The asbestos used in these components is usually found in a resin or sealed in some way. Normal handling is not hazardous as long as airborne dust containing asbestos is not generated.

Avoid creating dust. Never use compressed air for cleaning. Avoid brushing or grinding material containing asbestos. When servicing, wear an approved respirator. A special vacuum cleaner is recommended to clean asbestos. If not available, apply a mist of oil or water on the material containing asbestos.

Keep bystanders away from the area.



DX,DUST -19-15MAR91

10
9510
-UN-23AUG88
TS220

PRACTICE SAFE MAINTENANCE

Understand service procedure before doing work. Keep area clean and dry.

Never lubricate or service machine while it is moving. Keep hands, feet, and clothing from power-driven parts. Disengage all power and operate controls to relieve pressure. Lower equipment to the ground. Stop the engine. Remove the key. Allow machine to cool.

Securely support any machine elements that must be raised for service work.

Keep all parts in good condition and properly installed. Fix damage immediately. Replace worn or broken parts. Remove any buildup of grease, oil, or debris.

Disconnect battery ground cable (-) before making adjustments on electrical systems or welding on machine.



DX,SERV -19-04JUN90

-UN-23AUG88
TS218

10
05
10

USE PROPER TOOLS

Use tools appropriate to the work. Makeshift tools and procedures can create safety hazards.

Use power tools only to loosen threaded parts and fasteners.

For loosening and tightening hardware, use the correct size tools. **DO NOT** use U.S. measurement tools on metric fasteners. Avoid bodily injury caused by slipping wrenches.

Use only service parts meeting John Deere specifications.



-UN-08NOV89
TS779

DX,REPAIR -19-04JUN90

DISPOSE OF WASTE PROPERLY

Improperly disposing of waste can threaten the environment and ecology. Potentially harmful waste used with John Deere equipment include such items as oil, fuel, coolant, brake fluid, filters, and batteries.

Use leakproof containers when draining fluids. Do not use food or beverage containers that may mislead someone into drinking from them.

Do not pour waste onto the ground, down a drain, or into any water source.

Air conditioning refrigerants escaping into the air can damage the Earth's atmosphere. Government regulations may require a certified air conditioning service center to recover and recycle used air conditioning refrigerants.

Inquire on the proper way to recycle or dispose of waste from your local environmental or recycling center, or from your John Deere dealer.

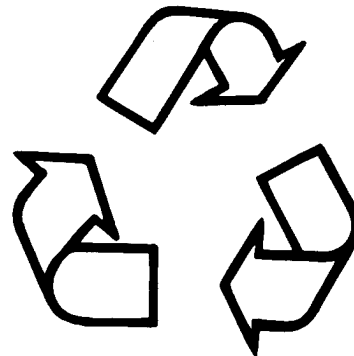

-UN-26NOV90
TS1133

DX,DRAIN -19-09AUG91

LIVE WITH SAFETY

Before returning machine to customer, make sure machine is functioning properly, especially the safety systems. Install all guards and shields.



DX,LIVE -19-04JUN90

TS231 -19-07OCT88

10
05
11

10
05
12

General Specifications/Specifications

10
10
2

HYDRAULIC SYSTEM

Lift Pump (optional) Oildyne Electro-Hydraulic Lift

CAPACITIES

Fuel Tank 9.5 L (2.5 U.S. gal)
 Engine Crankcase 1.4 L (3.0 U.S. pt)
 Wet Reduction Clutch Gearbox 0.6 L (1.3 U.S. pt)
 Transaxle 2.3 L (2.5 qt)

TIRES

Standard Equipment

Front One 22.5 x 10.00—8 2 PR High Floatation
 Rear Two 25 x 12.00—9 2 PR High Floatation

OVERALL DIMENSIONS:

Wheelbase 1054 mm (41.5 in.)
 Length 1676 mm (66 in.)
 Width 1473 mm (58 in.)
 Height 1041 mm (41 in.)
 Ground Clearance at
 Rake Attachment 241 mm (9.5 in.)
 Turning Radius 305 mm (12 in.)
 Approximate Shipping
 Weight 238 kg (525 lb)

(Specifications and design subject to change without notice.)

MX,1010HE,A2 -19-27SEP91

ATTACHMENT SPECIFICATIONS

RAKE (Standard)

Type Rear Mount, Hand Lift Control
 (Hydraulic Lift—Optional)
 Width 1981 mm (78 in.)
 Weight 20 kg (44 lb)
 Blades Five Section, Bunker or Field
 Prong Rake Three Section, 24 Prongs
 25—76 mm (1—3 in.) Adjustment

CULTIVATOR (Optional)

Type Mid-Mount, 10 Blades, Hand Control
 with 5-Position Depth Adjustment
 Width 1626 mm (64 in.)
 Weight 20 kg (44 lb)

FRONT BLADE (Optional)

Type Front-Mount, Hand Control with
 Up-Lock Position
 Width 1016 mm (40 in.)
 Height 152 mm (6 in.)
 Weight 25 kg (56 lb)

(Specifications and design subject to change without notice.)

MX,1010HE,A3 -19-27SEP91

REPAIR SPECIFICATIONS

Item	Measurement	Specification
SECTION 20—ENGINE REPAIR		
For all repair specifications—Use CTM5		
Engine-to-Frame Cap Screw	Torque	23 N·m (204 lb-in.)
Muffler-to-Engine Nut	Torque	14 N·m (124 lb-in.)
SECTION 30—FUEL AND AIR REPAIR		
For all carburetor repair specifications—Use CTM5		
SECTION 40—ELECTRICAL SYSTEM		
For all starter and engine ignition and charging system repair—Use CTM5		
Steering Wheel Nut-to-Shaft	Torque	197 N·m (145 lb-ft)
Neutral Start Switch-to-Transaxle	Torque	39 N·m (28 lb-ft)
SECTION 50—POWER TRAIN REPAIR		
Wet Reduction Clutch		
Output Shaft/Gear Gear Side Journal	OD (MIN)	0.25 mm (0.982 in.)
Output Shaft/Gear Shaft Side Journal	OD (MIN)	31.94 mm (1.257 in.)
Drive Hub Journal	OD (MIN)	36.92 mm (1.453 in.)
Clutch Drum Bushing	ID (MAX)	37.08 mm (1.460 in.)
	Installation Depth	1.50 mm (0.060 in.)
	Finished ID	37.00—37.03 mm (1.457—1.458 in.)
Clutch Springs	Free Length (MIN)	22.70 mm (0.890 in.)
Case Half-to-Engine Cap Screw	Torque	28 N·m (20 lb-ft)
Clutch Drum Assembly-to-Engine Crankshaft Cap Screw	Torque	55 N·m (40 lb-ft)
Case Cover-to-Case Half Cap Screw	Torque	28 N·m (20 lb-ft)

MX,1015HE,A1 -19-27SEP91

Item	Measurement	Specification
SECTION 50—POWER TRAIN REPAIR—CONTINUED		
Drive Clutch		
Drive Clutch-to-Output Shaft Cap Screw	Torque	50 N·m (37 lb-ft)
Roller Arm-to-Moveable Sheave Half Cap Screw	Torque	8 N·m (71 lb-in.)
Ramp Plate-to-Spider Cap Screw	Torque	12 N·m (107 lb-in.)
Driven Clutch Collar-to- Transaxle Input Shaft Set Screw	Torque	8 N·m (71 lb-in.)
Transaxle		
Input Shaft		
Washer	Thickness	1.55—1.65 mm (0.061—0.064 in.)
Washer	Thickness	1.45—1.55 mm (0.057—0.061 in.)
Reverse Drive Sprocket	ID	24.01—24.03 mm (0.945—0.946 in.)
Forward Drive Gear	ID	24.01—24.03 mm (0.945—0.946 in.)
Input Shaft	OD	19.99—20.01 mm (0.787—0.788 in.)
Shift Collar	Groove Width	14.10—14.30 mm (0.550—0.560 in.)
Shift Collar-to-Lock Fork Finger	Clearance (MAX)	2 mm (0.080 in.)
Shift Collar Spring	Free Length	24.20 mm (0.950 in.)
	Free Length (MIN)	20 mm (0.790 in.)
	Working Load	15.80 mm at 53N (0.620 in. at 12 lbs)

MX,1015HE,A2 -19-27SEP91

Item	Measurement	Specification
SECTION 50—POWER TRAIN REPAIR—CONTINUED		
Transaxle—continued		
Differential		
Differential Lock Collar	Groove Width	7.10—7.30 mm (0.280—0.290 in.)
Bevel Gear Washer	Thickness	0.74—0.86 mm (0.029—0.033 in.)
Pinion Gear Washer	Thickness	0.96—1.04 mm (0.038—0.041 in.)
Pinion Gear	ID	16.03—16.05 mm (0.631—0.632 in.)
Bevel Pinion Shaft	OD	15.95—15.97 mm (0.628—0.629 in.)
Shift-to-Pinion Gar	Clearance (MAX)	0.20 mm (0.010 in.)
Differential Half Nut	Torque	25 N·m (221 lb-in.)
Differential Lock Shaft		
Differential Lock Fork Finger	Thickness	6.70—6.90 mm (0.260—0.270 in.)
Differential Lock Fork	ID	20.05—20.10 mm (0.789—0.791 in.)
Finger-to-Collar Groove	Clearance (MAX)	2 mm (0.080 in.)
Differential Lock Shaft	OD	19.95—20.00 mm (0.785—0.787 in.)
Differential Lock Shaft-to-Fork	Clearance (MAX)	0.50 mm (0.020 in.)
Spring	Free Length	77.60 mm (3.060 in.)
	Working Load	52 mm at 511N (2.070 in. at 115 lbs)

MX,1015HE,A2A -19-27SEP91

Item	Measurement	Specification
SECTION 50—POWER TRAIN REPAIR—CONTINUED		
Transaxle—continued		
Shifter Arm Shifter Block	Width	13.70—13.90 mm (0.540—0.550 in.)
Block-to-Shift Collar Groove	Clearance (MAX)	2 mm (0.080 in.)
Shifter Arm Shaft	OD	16.96—17.00 mm (0.668—0.669 in.)
Transaxle Case Bore	ID	17.02—17.04 mm (0.670—0.671 in.)
Shaft-to-Case Bore	Clearance (MAX)	0.20 mm (0.010 in.)
Retaining Plate-to-Case Cap Screw	Torque	25 N·m (221 lb-in.)
Transaxle Case-Half Cap Screw	Torque (Same Case) (New Case)	25 N·m (221 lb-in.) 29 N·m (257 lb-in.)
Vent Tube-to-Transaxle	Torque	10 N·m (88 lb-in.)
Neutral Start Switch-to-Transaxle	Torque	39 N·m (28 lb-ft)
Flangette-to-Frame Nut	Torque	25 N·m (216 lb-in.)
Drive Axles		
Drive Axle-to-Frame	Distance	30.15 mm (1.187 in.)
Flangette-to-Frame Nut	Torque	25 N·m (216 lb-in.)
Locking Collar-to-Axle Shaft Set Screw	Torque	8 N·m (64 lb-in.)
SECTION 60—STEERING AND BRAKE REPAIR		
Locking Collar-to-Steering Shaft Set Screw	Torque	8 N·m (64 lb-in.)
Brake Housing Half Cap Screw	Torque	33 N·m (24 lb-ft)
Axle Bearing Flangette-to-Frame Nut	Torque	25 N·m (216 lb-in.)

Item	Measurement	Specification
SECTION 70—HYDRAULIC REPAIR		
Reservoir-to-Gear Pump Screw	Torque	5 N·m (45 lb-in.)
Gear Pump-to-Adapter Screw	Torque	8 N·m (70 lb-in.)
Hex Plug-to-Adapter	Torque	59 N·m (44 lb-ft)
Lower and Raise Relief Valve-to-Adapter Nut	Torque	2 N·m (20 lb-in.)
Thermal Relief Valve	Torque	7 N·m (60 lb-in.)
SECTION 80—MISCELLANEOUS REPAIR		
Steering Wheel Nut	Torque	197 N·m (145 lb-ft)
Rear Wheel Cap Screw	Torque	100 N·m (75 lb-ft)

MX,1015HE,A2C -19-27SEP91

TUNE-UP SPECIFICATIONS

Spark plug gap	0.64 mm (0.025 in.)
Spark plug torque	20 N·m (177 lb-in.)
Slow idle	
Stop screw setting	1300 rpm
Limiter screw setting	1300—1500 rpm
Fast idle limiter screw setting	3800 rpm

MX,1015HE,A3 -19-27SEP91

TUNE-UP ADJUSTMENTS

Perform tune-up adjustments in the following order to improve the efficiency and operation of the machine.

Tune-up Adjustment	Section	Group
1. Clean engine cooling fins.	See CTM5	
2. Clean or replace air cleaner element.	30	10
3. Check or replace fuel filter.	30	05
4. Check battery electrolyte level.	See Operators Manual	
5. Clean, regap or replace spark plug.	240	15
6. Check engine compression.	220	15
7. Adjust throttle cable.	230	15
8. Check and adjust choke.	230	15
9. Adjust governor.	230	15
10. Adjust slow idle stop and idle mixture screw.	230	15
11. Adjust slow idle limiter screw.	230	15
12. Adjust fast idle limiter screw.	230	15
13. Check and adjust brakes.	260	15
14. Check charging system output.	240	15
15. Check tire pressure.	See Operators Manual	

MX,1015HE,A4 -19-27SEP91

SERVICE RECOMMENDATIONS FOR O-RING BOSS FITTINGS

STRAIGHT FITTING

1. Inspect O-ring boss seat for dirt or defects.
2. Lubricate O-ring with petroleum jelly. Place electrical tape over threads to protect O-ring. Slide O-ring over tape and into O-ring groove of fitting. Remove tape.
3. Tighten fitting to torque value shown on chart.

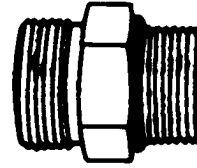

ANGLE FITTING

1. Back-off lock nut (A) and back-up washer (B) completely to head-end (C) of fitting.
2. Turn fitting into threaded boss until back-up washer contacts face of boss.
3. Turn fitting head-end counterclockwise to proper index (maximum of one turn).
4. Hold fitting head-end with a wrench and tighten locknut and back-up washer to proper torque value.

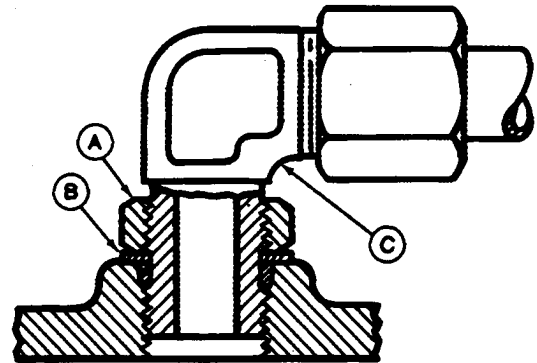

NOTE: Do not allow hoses to twist when tightening fittings.

TORQUE VALUE

Thread Size	N-m	lb-ft
3/8-24 UNF	8	6
7/16-20 UNF	12	9
1/2-20 UNF	16	12
9/16-18 UNF	24	18
3/4-16 UNF	46	34
7/8-14 UNF	62	46
1-1/16-12 UN	102	75
1-3/16-12 UN	122	90
1-5/16-12 UN	142	105
1-5/8-12 UN	190	140
1-7/8-12 UN	217	160

NOTE: Torque tolerance is $\pm 10\%$.

04T.90.K66 -19-13AUG91

10
15
7
-UN-18OCT88
T6249AE
-UN-18OCT88
T6520AB

METRIC BOLT AND CAP SCREW TORQUE VALUES

10
15
8

Property Class and Head Markings	4.8				8.8				9.8				10.9				12.9			
Property Class and Nut Markings	5				10				10				12							

TS1163 -19-04MAR91

Size	Class 4.8				Class 8.8 or 9.8				Class 10.9				Class 12.9			
	Lubricated ^a		Dry ^a		Lubricated ^a		Dry ^a		Lubricated ^a		Dry ^a		Lubricated ^a		Dry ^a	
	N-m	lb-ft	N-m	lb-ft	N-m	lb-ft	N-m	lb-ft	N-m	lb-ft	N-m	lb-ft	N-m	lb-ft	N-m	lb-ft
M6	4.8	3.5	6	4.5	9	6.5	11	8.5	13	9.5	17	12	15	11.5	19	14.5
M8	12	8.5	15	11	22	16	28	20	32	24	40	30	37	28	47	35
M10	23	17	29	21	43	32	55	40	63	47	80	60	75	55	95	70
M12	40	29	50	37	75	55	95	70	110	80	140	105	130	95	165	120
M14	63	47	80	60	120	88	150	110	175	130	225	165	205	150	260	190
M16	100	73	125	92	190	140	240	175	275	200	350	225	320	240	400	300
M18	135	100	175	125	260	195	330	250	375	275	475	350	440	325	560	410
M20	190	140	240	180	375	275	475	350	530	400	675	500	625	460	800	580
M22	260	190	330	250	510	375	650	475	725	540	925	675	850	625	1075	800
M24	330	250	425	310	650	475	825	600	925	675	1150	850	1075	800	1350	1000
M27	490	360	625	450	950	700	1200	875	1350	1000	1700	1250	1600	1150	2000	1500
M30	675	490	850	625	1300	950	1650	1200	1850	1350	2300	1700	2150	1600	2700	2000
M33	900	675	1150	850	1750	1300	2200	1650	2500	1850	3150	2350	2900	2150	3700	2750
M36	1150	850	1450	1075	2250	1650	2850	2100	3200	2350	4050	3000	3750	2750	4750	3500

DO NOT use these values if a different torque value or tightening procedure is given for a specific application. Torque values listed are for general use only. Check tightness of fasteners periodically.

Shear bolts are designed to fail under predetermined loads. Always replace shear bolts with identical property class.

Fasteners should be replaced with the same or higher property class. If higher property class fasteners are used, these should only be tightened to the strength of the original.

^a "Lubricated means coated with a lubricant such as engine oil, or fasteners with phosphate and oil coatings. "Dry means plain or zinc plated without any lubrication.

Make sure fasteners threads are clean and that you properly start thread engagement. This will prevent them from failing when tightening.

Tighten plastic insert or crimped steel-type lock nuts to approximately 50 percent of the dry torque shown in the chart, applied to the nut, not to the bolt head. Tighten toothed or serrated-type lock nuts to the full torque value.