

Product: John Deere 1200A Bunker and Field Vehicle Service Repair Technical Manual

Full Download: <https://www.bobmanualstore.com/downloads/john-deere-1200a-bu>

[nker-and-field-vehicle-service-repair-technical-manual/](https://www.bobmanualstore.com/downloads/john-deere-1200a-bu)

**JOHN DEERE**  
**WORLDWIDE COMMERCIAL & CONSUMER**  
**EQUIPMENT DIVISION**

---

**Bunker and Field Vehicle**  
**1200A**

TM1587 DEC05

**TECHNICAL MANUAL**



**JOHN DEERE**

North American Version  
Litho in U.S.A.

Sample manual. Download All 257 pages at:

<https://www.bobmanualstore.com/downloads/john-deere-1200a-bunker-and-field-vehicle-service-repair-technical-manual/>

Product: John Deere 1200A Bunker and Field Vehicle Service Repair Technical Manual  
Full Download: <https://www.bobmanualstore.com/downloads/john-deere-1200a-bunker-and-field-vehicle-service-repair-technical-manual/>

Sample manual. Download All 257 pages at:  
<https://www.bobmanualstore.com/downloads/john-deere-1200a-bunker-and-field-vehicle-service-repair-technical-manual/>

# INTRODUCTION

## Manual Description

This technical manual is written for an experienced technician and contains sections that are specifically for this product. It is a part of a total product support program.

The manual is organized so that all the information on a particular system is kept together. The order of grouping is as follows:

- Table of Contents
- Specifications and Information
- Identification Numbers
- Tools and Materials
- Component Location
- Schematics and Harnesses
- Theory of Operation
- Operation and Diagnostics
- Diagnostics
- Tests and Adjustments
- Repair
- Other

**NOTE: Depending on the particular section or system being covered, not all of the above groups may be used.**

The bleed tabs for the pages of each section will align with the sections listed on this page. Page numbering is consecutive from the beginning of the Safety section through the last section.

We appreciate your input on this manual. If you find any errors or want to comment on the layout of the manual, please contact us.

Safety

Specifications and Information

Engine - Gas

Electrical

Gear Power Train

Hydraulics/Power Train

Steering

Brakes

Attachments

Miscellaneous

All information, illustrations and specifications in this manual are based on the latest information at the time of publication. The right is reserved to make changes at any time without notice.

COPYRIGHT© 2005  
Deere & Co.  
John Deere Worldwide Commercial and  
Consumer Equipment Division  
All rights reserved  
Previous Editions  
COPYRIGHT© 1995



# SAFETY

## Recognize Safety Information

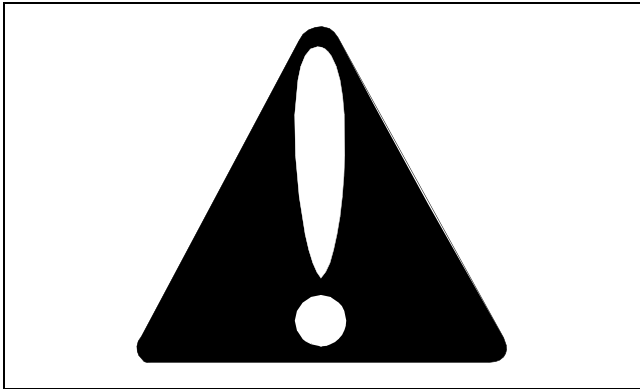

MIF

This is the safety-alert symbol. When you see this symbol on your machine or in this manual, be alert to the potential for personal injury.

Follow recommended precautions and safe servicing practices.

## Understand Signal Words

A signal word - DANGER, WARNING, or CAUTION - is used with the safety-alert symbol. DANGER identifies the most serious hazards.

DANGER or WARNING safety signs are located near specific hazards. General precautions are listed on CAUTION safety signs. CAUTION also calls attention to safety messages in this manual.

## Replace Safety Signs

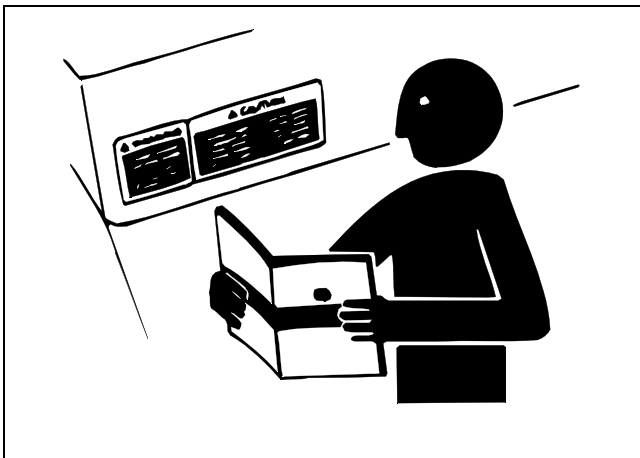

MIF

Replace missing or damaged safety signs. See the machine operator's manual for correct safety sign placement.

## Handle Fluids Safely - Avoid Fires

### Be Prepared for Emergencies

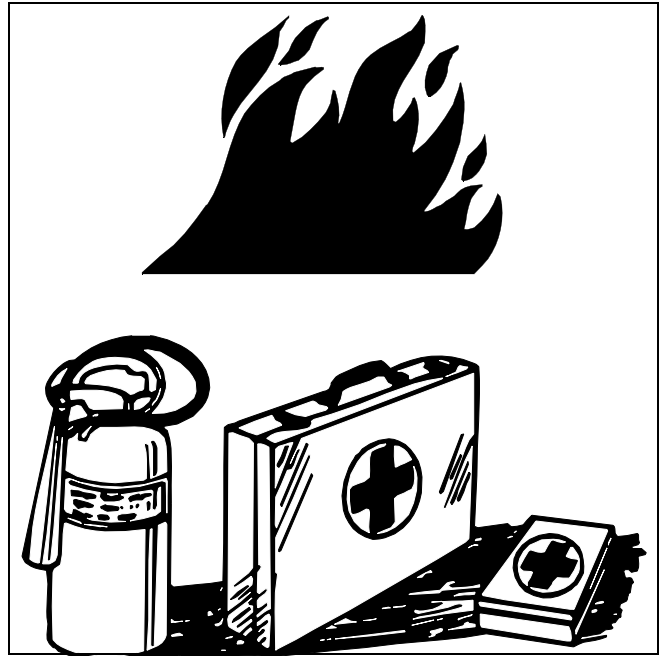

MIF

- When you work around fuel, do not smoke or work near heaters or other fire hazards.
- Store flammable fluids away from fire hazards. Do not incinerate or puncture pressurized containers.
- Make sure machine is clean of trash, grease, and debris.
- Do not store oily rags; they can ignite and burn spontaneously.
- Be prepared if a fire starts.
- Keep a first aid kit and fire extinguisher handy.
- Keep emergency numbers for doctors, ambulance service, hospital, and fire department near your telephone.

# SAFETY

## Use Care in Handling and Servicing Batteries

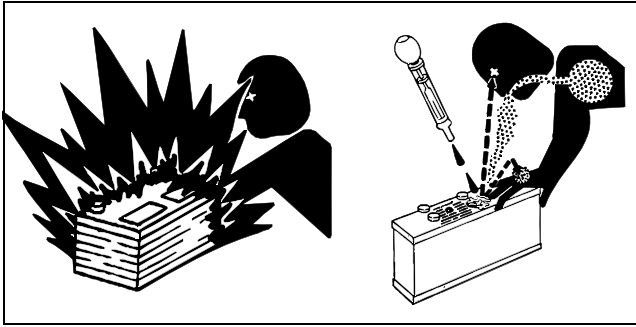

MIF

### Prevent Battery Explosions

- Keep sparks, lighted matches, and open flame away from the top of battery. Battery gas can explode.
- Never check battery charge by placing a metal object across the posts. Use a voltmeter or hydrometer.
- Do not charge a frozen battery; it may explode. Warm battery to 16°C (60°F).

### Prevent Acid Burns

- Sulfuric acid in battery electrolyte is poisonous. It is strong enough to burn skin, eat holes in clothing, and cause blindness if splashed into eyes.

#### Avoid acid burns by:

1. Filling batteries in a well-ventilated area.
2. Wearing eye protection and rubber gloves.
3. Avoiding breathing fumes when electrolyte is added.
4. Avoiding spilling or dripping electrolyte.
5. Using proper jump start procedure.

#### If you spill acid on yourself:

1. Flush your skin with water.
2. Apply baking soda or lime to help neutralize the acid.
3. Flush your eyes with water for 10-15 minutes.
4. Get medical attention immediately.

#### If acid is swallowed:

1. Drink large amounts of water or milk.
2. Then drink milk of magnesia, beaten eggs, or vegetable oil.
3. Get medical attention immediately.

## Wear Protective Clothing

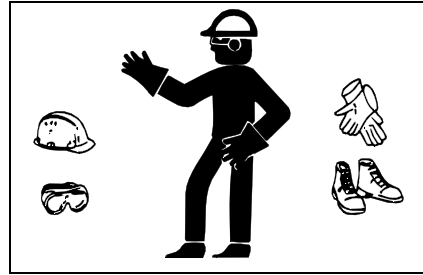

MIF

Wear close-fitting clothing and safety equipment appropriate to the job.

Prolonged exposure to loud noise can cause impairment or loss of hearing. Wear a suitable hearing protective device such as earmuffs or earplugs to protect against objectionable or uncomfortable loud noises.

Operating equipment safely requires the full attention of the operator. Do not wear radio or music headphones while operating machine.

## Use Care Around High-Pressure Fluid Lines

### Avoid High-Pressure Fluids



MIF

Escaping fluid under pressure can penetrate the skin causing serious injury.

Avoid injury from escaping fluid under pressure by stopping the engine and relieving pressure in the system before disconnecting or connecting hydraulic or other lines. Tighten all connections before applying pressure.

Search for leaks with a piece of cardboard. Protect hands and body from high-pressure fluids.

If an accident occurs, see a doctor immediately. Any fluid injected into the skin must be surgically removed within a few hours or gangrene may result. Doctors unfamiliar with this type of injury should reference a knowledgeable medical source. Such information is available from Deere & Company Medical Department in Moline, Illinois, U.S.A.

# SAFETY

## Avoid Heating Near Pressurized Fluid Lines



MIF

Flammable spray can be generated by heating near pressurized fluid lines, resulting in severe burns to yourself and bystanders. Do not heat by welding, soldering, or using a torch near pressurized fluid lines or other flammable materials. Pressurized lines can be accidentally cut when heat goes beyond the immediate flame area.

## Service Machines Safely

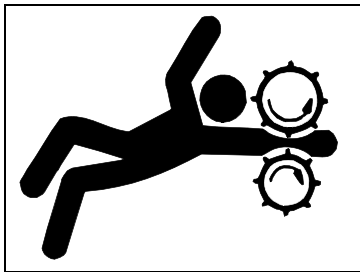

MIF

Tie long hair behind your head. Do not wear a necktie, scarf, loose clothing, or necklace when you work near machine tools or moving parts. If these items were to get caught, severe injury could result.

Remove rings and other jewelry to prevent electrical shorts and entanglement in moving parts.

## Use Proper Tools

Use tools appropriate to the work. Makeshift tools and procedures can create safety hazards. Use power tools only to loosen threaded parts and fasteners. For loosening and tightening hardware, use the correct size tools. **DO NOT** use U.S. measurement tools on metric fasteners. Avoid bodily injury caused by slipping wrenches. Use only service parts meeting John Deere specifications.

## Support Machine Properly and Use Proper Lifting Equipment

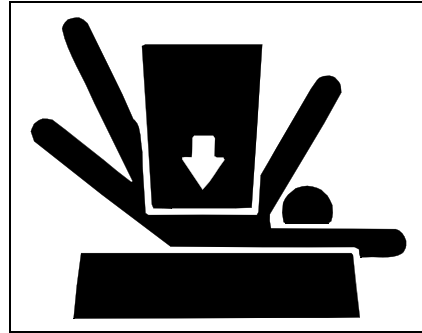

MIF

If you must work on a lifted machine or attachment, securely support the machine or attachment.

Do not support the machine on cinder blocks, hollow tiles, or props that may crumble under continuous load. Do not work under a machine that is supported solely by a jack. Follow recommended procedures in this manual.

Lifting heavy components incorrectly can cause severe injury or machine damage. Follow recommended procedure for removal and installation of components in the manual.

## Work in Clean Area

### Before starting a job:

1. Clean work area and machine.
2. Make sure you have all necessary tools to do your job.
3. Have the right parts on hand.
4. Read all instructions thoroughly; do not attempt shortcuts.

## Using High-Pressure Washers

Directing pressurized water at electronic/electrical components or connectors, bearings, hydraulic seals, fuel injection pumps or other sensitive parts and components may cause product malfunctions. Reduce pressure and spray at a 45- to 90-degree angle.

## Illuminate Work Area Safely

Illuminate your work area adequately but safely. Use a portable safety light for working inside or under the machine. Make sure the bulb is enclosed by a wire cage. The hot filament of an accidentally broken bulb can ignite spilled fuel or oil.

# SAFETY

## Work in Ventilated Area

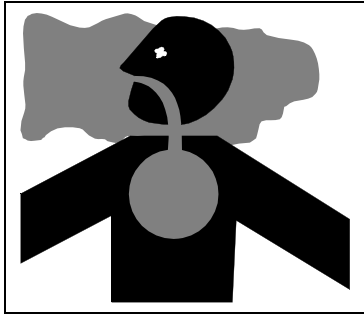

MIF

Engine exhaust fumes can cause sickness or death. If it is necessary to run an engine in an enclosed area, remove the exhaust fumes from the area with an exhaust pipe extension.

If you do not have an exhaust pipe extension, open the doors and get outside air into the area.

## Warning: California Proposition 65 Warning

Gasoline engine exhaust from this product contains chemicals known to the State of California to cause cancer, birth defects, or other reproductive harm.

Diesel engine exhaust and some of its constituents are known to the State of California to cause cancer, birth defects, and other reproductive harm.

## Remove Paint Before Welding or Heating

Avoid potentially toxic fumes and dust. Hazardous fumes can be generated when paint is heated by welding, soldering, or using a torch. Do all work outside or in a well-ventilated area. Dispose of paint and solvent properly. Remove paint before welding or heating: If you sand or grind paint, avoid breathing the dust. Wear an approved respirator. If you use solvent or paint stripper, remove stripper with soap and water before welding. Remove solvent or paint stripper containers and other flammable material from area. Allow fumes to disperse at least 15 minutes before welding or heating.

## Avoid Harmful Asbestos Dust

Avoid breathing dust that may be generated when handling components containing asbestos fibers. Inhaled asbestos fibers may cause lung cancer.

Components in products that may contain asbestos fibers are brake pads, brake band and lining assemblies, clutch plates, and some gaskets. The asbestos used in these components is usually found in a resin or sealed in some way. Normal handling is not hazardous as long as airborne dust containing asbestos is not generated.

Avoid creating dust. Never use compressed air for cleaning. Avoid brushing or grinding material containing asbestos. When servicing, wear an approved respirator. A special vacuum cleaner is recommended to clean asbestos. If not available, apply a mist of oil or water on the material containing asbestos. Keep bystanders away from the area.

## Service Tires Safely



MIF

Explosive separation of a tire and rim parts can cause serious injury or death.

Do not attempt to mount a tire unless you have the proper equipment and experience to perform the job.

Always maintain the correct tire pressure. Do not inflate the tires above the recommended pressure. Never weld or heat a wheel and tire assembly. The heat can cause an increase in air pressure resulting in a tire explosion. Welding can structurally weaken or deform the wheel.

When inflating tires, use a clip-on chuck and extension hose long enough to allow you to stand to one side and NOT in front of or over the tire assembly. Use a safety cage if available.

Check wheels for low pressure, cuts, bubbles, damaged rims or missing lug bolts and nuts.

# SAFETY

## Avoid Injury From Rotating Blades, Augers and PTO Shafts

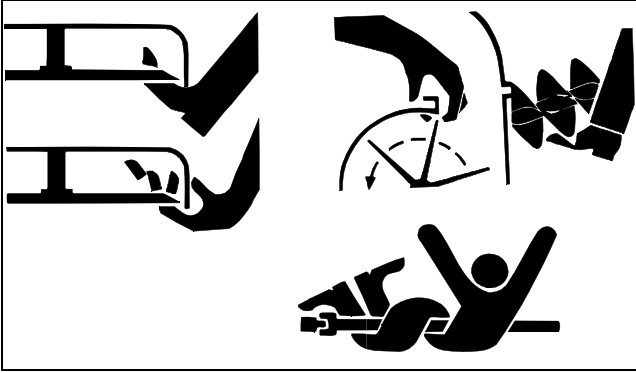

MIF

Keep hands and feet away while machine is running. Shut off power to service, lubricate or remove mower blades, augers or PTO shafts.

## Handle Chemical Products Safely

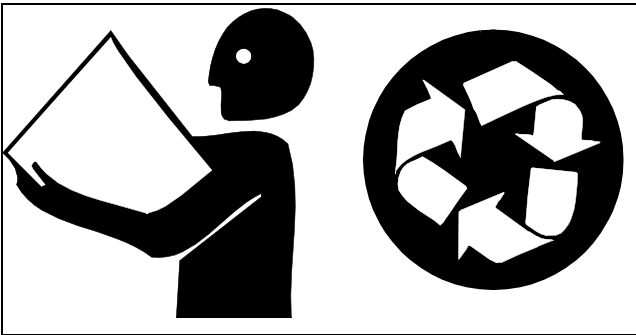

MIF

Direct exposure to hazardous chemicals can cause serious injury. Potentially hazardous chemicals used with John Deere equipment include such items as lubricants, coolants, paints, and adhesives.

A Material Safety Data Sheet (MSDS) provides specific details on chemical products: physical and health hazards, safety procedures, and emergency response techniques. Check the MSDS before you start any job using a hazardous chemical. That way you will know exactly what the risks are and how to do the job safely. Then follow procedures and use recommended equipment.

## Dispose of Waste Properly

Improperly disposing of waste can threaten the environment and ecology. Potentially harmful waste used with John Deere equipment includes such items as oil, fuel, coolant, brake fluid, filters, and batteries. Use leakproof containers when draining fluids. Do not use food or beverage containers that may mislead someone into drinking from them. Do not pour waste onto the ground, down a drain, or into any water source. Inquire on the proper way to recycle or dispose of waste from your local environmental or recycling center, or from your John Deere dealer.

## Parking Safely

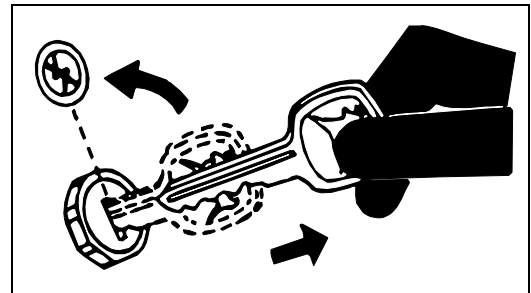

MIF

1. Stop machine on a level surface, not on a slope.
2. Disengage and stop attachments.
3. Lower attachments to the ground.
4. Lock park brake.
5. Stop engine.
6. Remove key.
7. Wait for engine and all moving parts to stop before you leave the operator station.
8. Close fuel shut-off valve, if your machine is equipped.

## Live With Safety



MIF

Before returning machine to customer, make sure machine is functioning properly, especially the safety systems. Install all guards and shields.

# SPECIFICATIONS AND INFORMATION TABLE OF CONTENTS

---

## Table of Contents

<b>Specifications .....</b>	<b>9</b>
Vehicle Specifications .....	9
<b>Fastener Torques.....</b>	<b>12</b>
Metric Fastener Torque Values .....	12
Metric Fastener Torque Values - Grade 7 ....	13
Inch Fastener Torque Values .....	14
<b>O-Ring Seal Service Recommendations .....</b>	<b>15</b>
Face Seal Fittings with Inch Stud Ends Torque .....	15
Face Seal Fittings with Metric Stud Ends Torque .....	16
O-Ring Face Seal Fittings .....	17
O-Ring Boss Fittings .....	17
Straight Fitting or Special Nut Torques .....	18
Metric Fastener Torque Value - Grade 7 (Special) .....	18
<b>General Information.....</b>	<b>19</b>
Gasoline .....	19
Gasoline Storage.....	19
4-Cycle Gasoline Engine Oil .....	19
Alternative Lubricants.....	20
Synthetic Lubricants .....	20
Lubricant Storage .....	20
Mixing of Lubricants .....	20
Oil Filters .....	20
<b>Serial Number Locations .....</b>	<b>21</b>
Product Serial Number .....	21
Engine Serial Number .....	21
Carburetor Serial Number .....	21
Transaxle Serial Number.....	21
Optional Hydraulic Pump Serial Number.....	21

# SPECIFICATIONS AND INFORMATION TABLE OF CONTENTS

---

---



# SPECIFICATIONS AND INFORMATION SPECIFICATIONS

## Specifications

### Vehicle Specifications

#### Engine

Make	John Deere "K" Series
Type	Gasoline
Model	FE290D-AS11
Aspiration	Natural
Cylinders	1
Displacement	286 mL (17.5 cu in.)
Stroke/Cycle	4-cycle
Bore	78 mm (3.070 in.)
Stroke	60 mm (2.360 in.)
Compression Ratio	8.4:1
Slow Idle	1175 ± 75 rpm
Fast Idle	3100 ± 75 rpm
Valving	Overhead valves
Lubrication	Pressurized
Engine Oil Capacity (With Filter)	1.30 L (2.75 pt)
Oil Filter	Full flow filter, spin on
Cooling System	Air cooled
Air Cleaner	Heavy duty with replaceable filter element
Muffler	Horizontal discharge below frame

#### Fuel System

Fuel Tank Location	Behind driver, left side
Fuel Tank Capacity	13.25 L (3.5 gal)
Fuel	Unleaded gasoline (minimum 87 octane)
Fuel Pump Location	On right side of engine
Fuel Delivery	Side draft carburetor
Fuel Filter	Replaceable, in-line

#### Electrical System

Ignition	Electronic CDI
Type of Starter	Solenoid shift
Charging System	Flywheel alternator
Charging Capacity	13 amp at 3000 rpm, regulated
Battery Type	BCI Group U1
Battery Voltage	12V
Battery Reserve Capacity at 25 Amps	RC 38
Battery Cold Cranking Amps at -18°C (0°F)	295 amps
Headlights	Halogen
Gages	Voltmeter, hour meter
Ignition Interlock Switches	Neutral start

# SPECIFICATIONS AND INFORMATION SPECIFICATIONS

---

## Power Train

### Clutch

Type ..... Continuously variable, belt-driven torque converter

### Transaxle

Type ..... Fully enclosed, oil bath

Transaxle Lubricant Capacity ..... 2.3 L (2.5 qt)

Lubricant Type ..... John Deere 85W140 API GL-5 Gear Oil

Gear Selection ..... Forward, neutral, reverse

Reduction Ratio ..... 17.03:1

Differential Lock ..... Hand operated

Travel Speed at Governed Fast Idle ..... 18.50 km/h (11.5 mph)

### Steering

Type ..... Mechanical, roller-chain and sprocket

Ratio ..... 8.4:1

### Brakes

Location ..... Transaxle

Type ..... External disk, single pedal

Park Brake ..... Brake pedal locking lever

### Weights and Dimensions

Empty Weight (Less Attachments) ..... 246 kg (542 lb)

Wheel Base ..... 1.054 m (41.5 in.)

Overall Width (Less Attachments) ..... 1.473 m (58 in.)

Overall Length ..... 1.676 m (66 in.)

Overall Height ..... 1.041 m (41 in.)

Turning Radius (Inside Rear Wheel) ..... 205 mm (12 in.)

Ground Clearance at Rake Attachment ..... 241 mm (9.5 in.)

### Wheels and Tires

Front ..... One 22.5 x 10.00-8 2PR high flotation

Rear ..... Two 25 x 12.00-9 2PR high flotation

Tire Air Pressure ..... 27.6-41.4 kpa (4-6 psi)

### Attachments and Kits

#### Front-Mounted Attachments

Lift System ..... Manual with up-lock position

Lift Assist Type ..... Fixed spring

Lift Lever Location ..... Right side of platform

#### Front Blade (Optional)

Width ..... 1016 mm (40 in.)

Height ..... 152 mm (6 in.)

Weight ..... 25 kg (56 lb)

# SPECIFICATIONS AND INFORMATION SPECIFICATIONS

## 60-Inch Aluminum Blade (Optional, Mounts to Optional Front Blade)

Width .....	1626 mm (60 in.)
Height .....	152 mm (6 in.)
Weight (Blade Only) .....	3.6 kg (8 lb)
Weight (60-Inch Blade With 40-inch Front Blade) .....	29 kg (64 lb)

## Core Removal Blade (Optional, Mounts to Optional Front Blade)

Width .....	1231 mm (48 in.)
Height .....	237 mm (9.25 in.)
Weight .....	10.9 kg (24 lb)

## Mid-Mounted Attachments

Lift System Manual (hand control) with 5-position depth adjustment

Lift Assist Type .....	Fixed spring
Lift Lever Location .....	Right side of seat

## Cultivator (Optional, Mounts to Optional Mid-mounted Base)

Type .....	10 blades
Width .....	1626 mm (64 in.)
Weight .....	20 kg (44 lb)

## 64.5-Inch Scraper Blade (Mounts to Optional Mid-mounted Base With Either Wide or Narrow Scarifier Tines Also Attached)

Width .....	1654 mm (64.5 in.)
Height .....	144 mm (5.625 in.)
Weight .....	20 kg (21 lb)
Mounting .....	Two bolts attach it to cultivator toolbar

## Wide- and Narrow-Interval Scarificer Tines Attachment (Mounts to Optional Mid-mounted Base)

Width .....	Wide - 1622 mm (63.25 in.)
.....	Narrow - 1590 mm (62 in.)
Weight .....	Wide - 10 kg (22 lb)
.....	Narrow - 11.3 kg (25 lb)
Tines .....	Wide - 20 Tines, 90 mm (3.50 in.) long
.....	Narrow - 35 Tines, 90 mm (3.50 in.) long

## Rear-Mounted Attachments

Lift System Electro-mechanical (hydraulic - optional)

Lift Switch Location .....	Right side of dash panel
----------------------------	--------------------------

## Bunker/Field Rake (Optional, Mounts to Optional Rear Frame)

Width .....	1981 mm (78 in.)
Weight .....	20 kg (44 lb)
Blades .....	Five-section, bunker or field
Prong Rake .....	Three-section, 24 prongs 25-76 mm (1-3 in.) adjustment

## Field Finisher (Optional, Mounts to Optional Rear Frame)





Width .....	1538 mm (60 in.)
Weight .....	1.8 kg (40 lb)

**NOTE: Specifications and design subject to change without notice.**

# SPECIFICATIONS AND INFORMATION FASTENER TORQUES

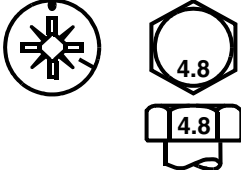
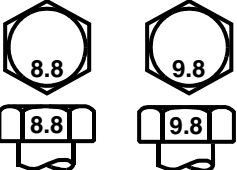
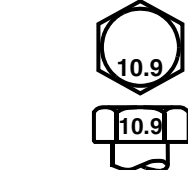
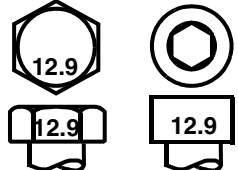
## Fastener Torques

### Metric Fastener Torque Values

Property Class and Head Markings	4.8 	8.8      9.8 	10.9 	12.9 
Property Class and Nut Markings	5 	10 	10 	12 

MIF (TS1163)

SIZE	Class 4.8				Class 8.8 or 9.8				Class 10.9				Class 12.9			
	Lubricated <sup>1</sup>		Dry <sup>1</sup>		Lubricated <sup>1</sup>		Dry <sup>1</sup>		Lubricated <sup>1</sup>		Dry <sup>1</sup>		Lubricated <sup>1</sup>		Dry <sup>1</sup>	
	N•m	lb-ft	N•m	lb-ft	N•m	lb-ft	N•m	lb-ft	N•m	lb-ft	N•m	lb-ft	N•m	lb-ft	N•m	lb-ft
M6	4.8	3.5	6	4.5	9	6.5	11	8.5	13	9.5	17	12	15	11.5	19	14.5
M8	12	8.5	15	11	22	16	28	20	32	24	40	30	37	28	47	35
M10	23	17	29	21	43	32	55	40	63	47	80	60	75	55	95	70
M12	40	29	50	37	75	55	95	70	110	80	140	105	130	95	165	120
M14	63	47	80	60	120	88	150	110	175	130	225	165	205	150	260	109
M16	100	73	125	92	190	140	240	175	275	200	350	225	320	240	400	300
M18	135	100	175	125	260	195	330	250	375	275	475	350	440	325	560	410
M20	190	140	240	180	375	275	475	350	530	400	675	500	625	460	800	580
M22	260	190	330	250	510	375	650	475	725	540	925	675	850	625	1075	800
M24	330	250	425	310	650	475	825	600	925	675	1150	850	1075	800	1350	1000
M27	490	360	625	450	950	700	1200	875	1350	1000	1700	1250	1600	1150	2000	1500
M30	675	490	850	625	1300	950	1650	1200	1850	1350	2300	1700	2150	1600	2700	2000
M33	900	675	1150	850	1750	1300	2200	1650	2500	1850	3150	2350	2900	2150	3700	2750
M36	1150	850	1450	1075	2250	1650	2850	2100	3200	2350	4050	3000	3750	2750	4750	3500

1. "Lubricated" means coated with a lubricant such as engine oil, or fasteners with phosphate and oil coatings. "Dry" means plain or zinc plated (yellow dichromate - Specification JDS117) without any lubrication.

DO NOT use these hand torque values if a different torque value or tightening procedure is given for a specific application. Torque values listed are for general use only and include a ±10% variance factor. Check tightness of fasteners periodically. DO NOT use air-powered wrenches.

Shear bolts are designed to fail under predetermined loads. Always replace shear bolts with identical grade.

Fasteners should be replaced with the same class. Make sure that fastener threads are clean and that you properly start thread engagement. This will prevent them from failing when tightening.

When bolt and nut combination fasteners are used, torque values should be applied to the NUT instead of the bolt head.

# SPECIFICATIONS AND INFORMATION FASTENER TORQUES

Tighten toothed or serrated-type locknuts to the full torque value.









Reference: JDS-G200.

## Metric Fastener Torque Values - Grade 7

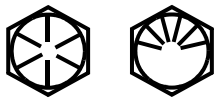
Size	Steel or Gray Iron Torque		Aluminum Torque	
	N•m	lb-ft	N•m	lb-ft
M6	11	8	8	6
M8	24	18	19	14
M10	52	38	41	30
M12	88	65	70	52
M14	138	102	111	82
M16	224	165	179	132

# SPECIFICATIONS AND INFORMATION FASTENER TORQUES

## Inch Fastener Torque Values

<b>SAE Grade and Head Markings</b>	1 or 2 <sup>1</sup> No Marks 	5    5.1    5.2 	8    8.2 
<b>SAE Grade and Nut Markings</b>	2 No Marks 	5  	8  

MIF (TS1162)

SIZE	Grade 1		Grade 2 <sup>1</sup>		Grade 5, 5.1 or 5.2		Grade 8 or 8.2									
	Lubricated <sup>2</sup>	Dry <sup>2</sup>	Lubricated <sup>2</sup>	Dry <sup>2</sup>	Lubricated <sup>2</sup>	Dry <sup>2</sup>	Lubricated <sup>2</sup>	Dry <sup>2</sup>								
	N•m	lb-ft	N•m	lb-ft	N•m	lb-ft	N•m	lb-ft								
1/4	3.7	2.8	4.7	3.5	6	4.5	7.5	5.5	9.5	7	12	9	13.5	10	17	12.5
5/16	7.7	5.5	10	7	12	9	15	11	20	15	25	18	28	21	35	26
3/8	14	10	17	13	22	16	27	20	35	26	44	33	50	36	63	46
7/16	22	16	28	20	35	26	44	32	55	41	70	52	80	58	100	75
1/2	33	25	42	31	53	39	67	50	85	63	110	80	120	90	150	115
9/16	48	36	60	45	75	56	95	70	125	90	155	115	175	130	225	160
5/8	67	50	85	62	105	78	135	100	170	125	215	160	215	160	300	225
3/4	120	87	150	110	190	140	240	175	300	225	375	280	425	310	550	400
7/8	190	140	240	175	190	140	240	175	490	360	625	450	700	500	875	650
1	290	210	360	270	290	210	360	270	725	540	925	675	1050	750	1300	975
1-1/8	470	300	510	375	470	300	510	375	900	675	1150	850	1450	1075	1850	1350
1-1/4	570	425	725	530	570	425	725	530	1300	950	1650	1200	2050	1500	2600	1950
1-3/8	750	550	950	700	750	550	950	700	1700	1250	2150	1550	2700	2000	3400	2550
1-1/2	1000	725	1250	925	990	725	1250	930	2250	1650	2850	2100	3600	2650	4550	3350

1. "Grade 2" applies for hex cap screws (not hex bolts) up to 152 mm (6 in.) long. "Grade 1" applies for hex cap screws over 152 mm (6 in.) long, and for all other types of bolts and screws of any length.

2. "Lubricated" means coated with a lubricant such as engine oil, or fasteners with phosphate and oil coatings. "Dry" means plain or zinc plated (yellow dichromate - Specification JDS117) without any lubrication.

DO NOT use these hand torque values if a different torque value or tightening procedure is given for a specific application. Torque values listed are for general use only and include a ±10% variance factor. Check tightness of fasteners periodically. DO NOT use air-powered wrenches.

Shear bolts are designed to fail under predetermined loads. Always replace shear bolts with identical grade.

Fasteners should be replaced with the same grade. Make sure that fastener threads are clean and that you properly

start thread engagement. This will prevent them from failing when tightening.

When bolt and nut combination fasteners are used, torque values should be applied to the NUT instead of the bolt head.

Tighten toothed or serrated-type locknuts to the full torque value.

Reference: JDS-G200.

# SPECIFICATIONS AND INFORMATION O-RING SEAL SERVICE

## O-Ring Seal Service Recommendations

### Face Seal Fittings with Inch Stud Ends Torque

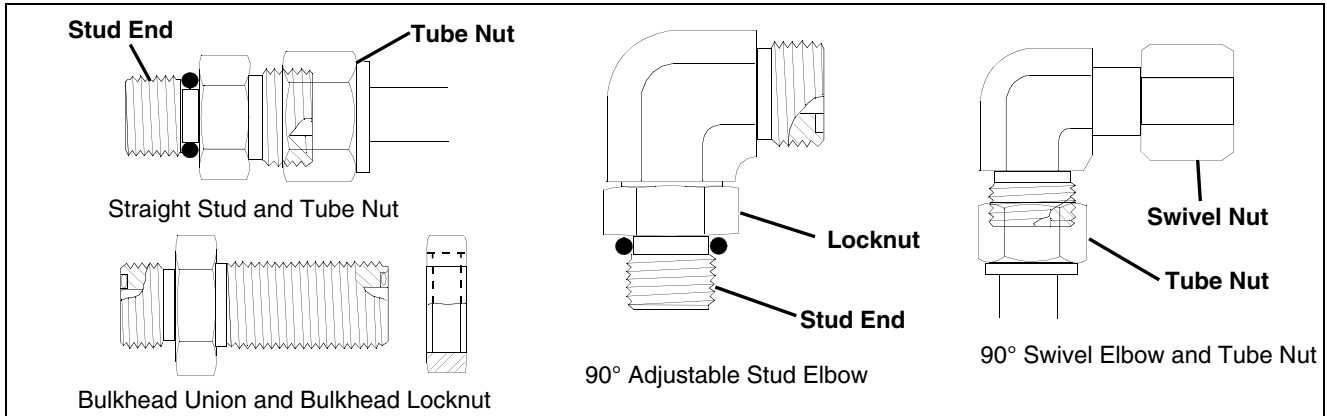

MIF

Nominal Tube OD/Hose ID				Face Seal Tube/Hose End					O-Ring Stud Ends		
Metric Tube OD	Inch Tube OD			Thread Size	Tube Nut/ Swivel Nut Torque		Bulkhead Locknut Torque		Thread Size	Straight Fitting or Locknut Torque	
	mm	Dash Size	in.		mm	in.	N•m	lb-ft		N•m	lb-ft
	-3	0.188	4.76						3/8-24	8	6
6	-4	0.250	6.35	9/16-18	16	12	12	9	7/16-20	12	9
8	-5	0.312	7.94						1/2-20	16	12
10	-6	0.375	9.52	11/16-16	24	18	24	18	9/16-18	24	18
12	-8	0.500	12.70	13/16-16	50	37	46	34	3/4-16	46	34
16	-10	0.625	15.88	1-14	69	51	62	46	7/8-14	62	46
	-12	0.750	19.05	1-3/16-12	102	75	102	75	1-1/16-12	102	75
22	-14	0.875	22.22	1-3/16-12	102	75	102	75	1-3/16-12	122	90
25	-16	1.000	25.40	1-7/16-12	142	105	142	105	1-5/16-12	142	105
32	-20	1.25	31.75	1-11/16-12	190	140	190	140	1-5/8-12	190	140
38	-24	1.50	38.10	2-12	217	160	217	160	1-7/8-12	217	160

**NOTE: Torque tolerance is +15%, -20%.**

# SPECIFICATIONS AND INFORMATION O-RING SEAL SERVICE

## Face Seal Fittings with Metric Stud Ends Torque

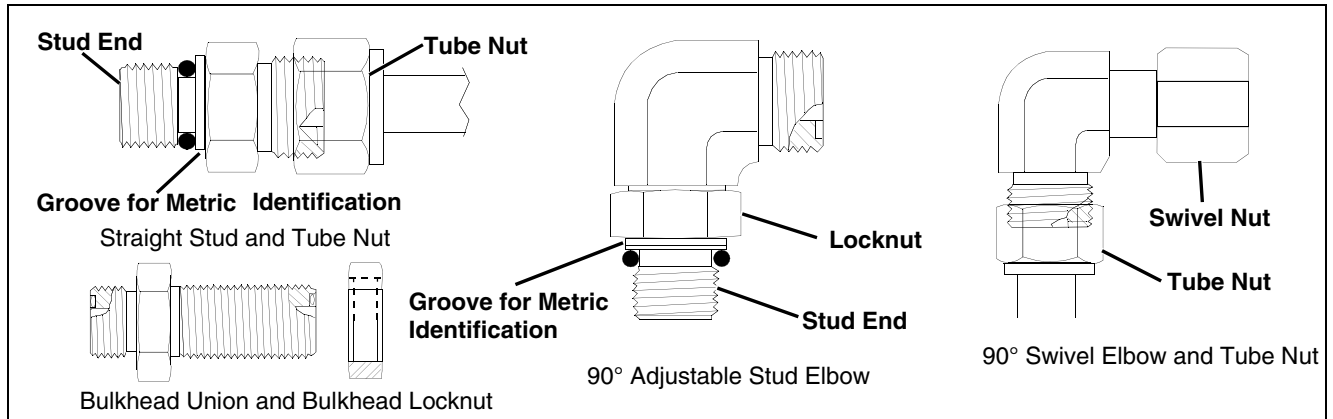

MIF

Nominal Tube OD/Hose ID				Face Seal Tube/Hose End						O-Ring Stud Ends, Straight Fitting or Locknut					
Metric Tube OD	Inch Tube OD			Thread Size	Hex Size	Tube Nut/ Swivel Nut Torque		Bulkhead Locknut Torque		Thread Size	Hex Size	Steel or Gray Iron Torque		Aluminum Torque	
	mm	Dash Size	in.			mm	in.	mm	N•m			lb-ft	N•m	lb-ft	mm
6	-4	0.250	6.35	9/16-18	17	16	12	12	9	M12x1.5	17	21	15.5	9	6.6
8	-5	0.312	7.94												
										M14x1.5	19	33	24	15	11
10	-6	0.375	9.52	11/16-16	22	24	18	24	18	M16x1.5	22	41	30	18	13
12	-8	0.500	12.70	13/16-16	24	50	37	46	34	M18x1.5	24	50	37	21	15
16	-10	0.625	15.88	1-14	30	69	51	62	46	M22x1.5	27	69	51	28	21
	-12	0.750	19.05	1-3/16-12	36	102	75	102	75	M27x2	32	102	75	46	34
22	-14	0.875	22.22	1-3/16-12	36	102	75	102	75	M30x2	36				
25	-16	1.000	25.40	1-7/16-12	41	142	105	142	105	M33x2	41	158	116	71	52
28										M38x2	46	176	130	79	58
32	-20	1.25	31.75	1-11/16-12	50	190	140	190	140	M42x2	50	190	140	85	63
38	-24	1.50	38.10	2-12	60	217	160	217	160	M48x2	55	217	160	98	72

**NOTE: Torque tolerance is +15%, -20%.**

# SPECIFICATIONS AND INFORMATION O-RING SEAL SERVICE

## O-Ring Face Seal Fittings

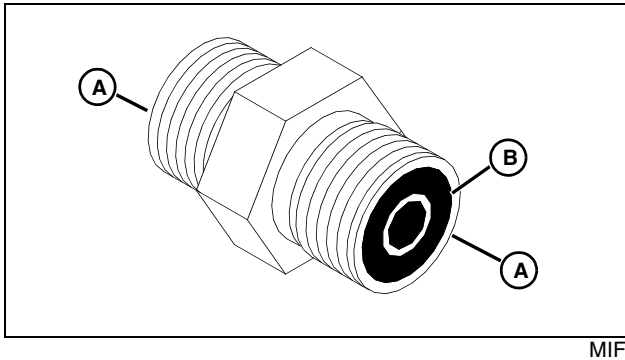

1. Inspect the fitting sealing surfaces (A). They must be free of dirt or defects.
2. Inspect the O-ring (B). It must be free of damage or defects.
3. Lubricate O-ring and install into groove using petroleum jelly to hold in place.
4. Push O-ring into the groove with plenty of petroleum jelly so O-ring is not displaced during assembly.
5. Index angle fittings and tighten by hand-pressing joint together to ensure O-ring remains in place.

**IMPORTANT: Avoid damage! DO NOT allow hoses to twist when tightening fittings. Use two wrenches to tighten hose connections: one to hold the hose, and the other to tighten the swivel fitting.**

6. Tighten fitting or nut to torque value shown on the chart per dash size stamped on the fitting.

## O-Ring Boss Fittings

1. Inspect O-ring boss seat. It must be free of dirt and defects. If repeated leaks occur, inspect for defects with a magnifying glass. Some raised defects can be removed with a slip stone.

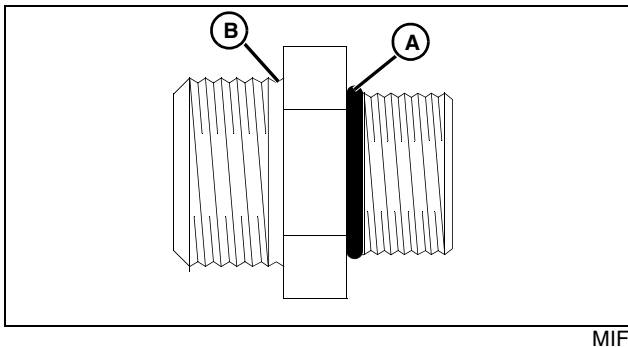

2. Put hydraulic oil or petroleum jelly on the O-ring (A). Place electrical tape over the threads to protect O-ring from nicks. Slide O-ring over the tape and into the groove (B) of fitting. Remove tape.

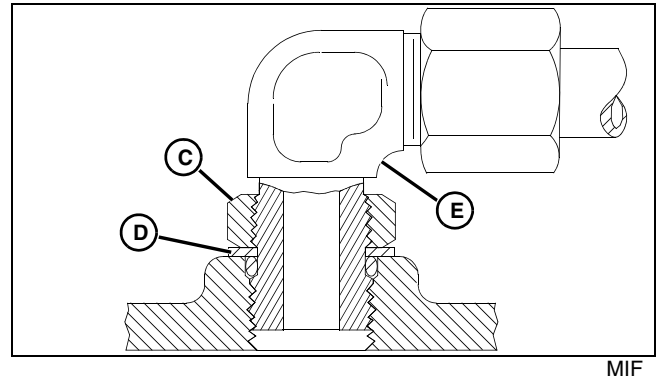

3. For angle fittings, loosen special nut (C) and push special washer (D) against threads so O-ring can be installed into the groove of fitting.
4. Turn fitting into the boss by hand until special washer or washer face (straight fitting) contacts boss face and O-ring is squeezed into its seat.
5. To position angle fittings (E), turn the fitting counter-clockwise a maximum of one turn.
6. Tighten straight fittings to torque value shown on chart. For angle fittings, tighten the special nut to value shown in the chart while holding body of fitting with a wrench.

### Straight Fitting or Special Nut Torque

Thread Size	Torque <sup>1</sup>		Number of Flats <sup>2</sup>
	N•m	lb-ft	
3/8-24 UNF	8	6	2
7/16-20 UNF	12	9	2
1/2-20 UNF	16	12	2
9/16-18 UNF	24	18	2
3/4-16 UNF	46	34	2
7/8-14 UNF	62	46	1-1/2
1-1/16-12 UN	102	75	1
1-3/16-12 UN	122	90	1
1-5/16-12 UN	142	105	3/4
1-5/8-12 UN	190	140	3/4
1-7/8-12 UN	217	160	1/2

1. Torque tolerance is  $\pm 10$  percent.

2. To be used if a torque wrench cannot be used. After tightening fitting by hand, put a mark on nut or boss, then tighten special nut or straight fitting the number of flats shown.

# SPECIFICATIONS AND INFORMATION O-RING SEAL SERVICE

## Straight Fitting or Special Nut Torques

Thread Size	Torque <sup>a</sup>		Number of Flats <sup>b</sup>
	N•m	lb-ft	
3/8-24 UNF	8	6	2
7/16-20 UNF	12	9	2
1/2-20 UNF	16	12	2
9/16-18 UNF	24	18	2
3/4-16 UNF	46	34	2
7/8-14 UNF	62	46	1-1/2
1-1/16-12 UN	102	75	1
1-3/16-12 UN	122	90	1
1-5/16-12 UN	142	105	3/4
1-5/8-12 UN	190	140	3/4
1-7/8-12 UN	217	160	1/2

<sup>a</sup>Torque tolerance is  $\pm 10$  percent.

<sup>b</sup>To be used if a torque wrench cannot be used. After tightening fitting by hand, put a mark on nut or boss; then tighten special nut or straight fitting the number of flats shown.

## Metric Fastener Torque Value - Grade 7 (Special)

Size	Steel or Gray Iron Torque	Aluminum Torque
	N•m (lb-ft)	N•m (lb-ft)
M6	11 (8)	8 (6)
M8	24 (18)	19 (14)
M10	52 (38)	41 (30)
M12	88 (65)	70 (52)
M14	138 (102)	111 (82)
M16	224 (165)	179 (132)

# SPECIFICATIONS AND INFORMATION GENERAL INFORMATION

## General Information

### Gasoline

#### 4-Cycle Engines



**CAUTION: Avoid Injury! Gasoline is HIGHLY FLAMMABLE**, handle it with care. **DO NOT** refuel machine while: indoors, always fill gas tank outdoors; machine is near an open flame or sparks; engine is running, **STOP** engine; engine is hot, allow it to cool sufficiently first; smoking.

Help prevent fires: fill gas tank to bottom of filler neck only; be sure fill cap is tight after fueling; clean up any gas spills **IMMEDIATELY**; keep machine clean and in good repair - free of excess grease, oil, debris, and faulty or damaged parts; any storage of machines with gas left in tank should be in an area that is well ventilated to prevent possible igniting of fumes by an open flame or spark, this includes any appliance with a pilot light. To prevent fire or explosion caused by **STATIC ELECTRIC DISCHARGE** during fueling: **ONLY** use a clean, approved **POLYETHYLENE PLASTIC** fuel container and funnel **WITHOUT** any metal screen or filter.

#### To avoid engine damage:

- DO NOT mix oil with gasoline.
- **ONLY** use clean, fresh unleaded gasoline with an octane rating (anti-knock index) of 87 or higher.
- Fill gas tank at the end of each day's operation to help prevent condensation from forming inside a partially filled tank.
- Keep up with specified service intervals.

Use of alternative oxygenated, gasohol blended, unleaded gasoline is acceptable as long as:

- The ethyl or grain alcohol blends **DO NOT** exceed 10% by volume.
- Methyl tertiary butyl ether (MTBE) blends **DO NOT** exceed 15% by volume.

RFG (reformulated) gasoline is acceptable for all machines designed for use of regular unleaded fuel. Older machines (that were designed for leaded fuel) may see some accelerated valve and seat wear.

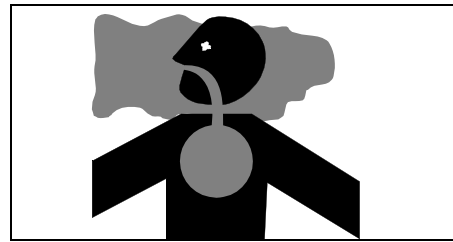

MIF

**IMPORTANT: Avoid damage! California Proposition 65 Warning: Gasoline engine exhaust from this product contains chemicals known to the State of California to cause cancer, birth defects, or other reproductive harm.**

### Gasoline Storage

**IMPORTANT: Avoid damage! Keep all dirt, scale, water or other foreign material out of gasoline.**

Keep gasoline stored in a safe, protected area. Storage of gasoline in a clean, properly marked ("UNLEADED GASOLINE") POLYETHYLENE PLASTIC container WITHOUT any metal screen or filter is recommended. **DO NOT** use de-icers to attempt to remove water from gasoline or depend on fuel filters to remove water from gasoline. Use a water separator installed in the storage tank outlet. **BE SURE** to properly discard unstable or contaminated gasoline. When storing the machine or gasoline, it is recommended that you add John Deere Gasoline Conditioner and Stabilizer (TY15977) or an equivalent to the gasoline. **BE SURE** to follow directions on container and to properly discard empty container.

### 4-Cycle Gasoline Engine Oil

Use the appropriate oil viscosity based on the expected air temperature range during the period between recommended oil changes. Operating outside of these recommended oil air temperature ranges may cause premature engine failure.

The following John Deere oils are **PREFERRED**:

- PLUS-4<sup>®</sup> - SAE 10W-40.
- TORQ-GARD SUPREME<sup>®</sup> - SAE 5W-30.

The following John Deere oils are **also recommended**, based on their specified temperature range:

- TURF-GARD<sup>®</sup> - SAE 10W-30.
- PLUS-4<sup>®</sup> - SAE 10W-30.
- TORQ-GARD SUPREME<sup>®</sup> - SAE 30.

Other oils may be used if above John Deere oils are not available, provided they meet one of the following specifications:

# SPECIFICATIONS AND INFORMATION GENERAL INFORMATION

- SAE 10W-40 - API Service Classifications SG or higher.
- SAE 5W-30 - API Service Classification SG or higher.
- SAE 10W-30 - API Service Classifications SG or higher.
- SAE 30 - API Service Classification SC or higher.

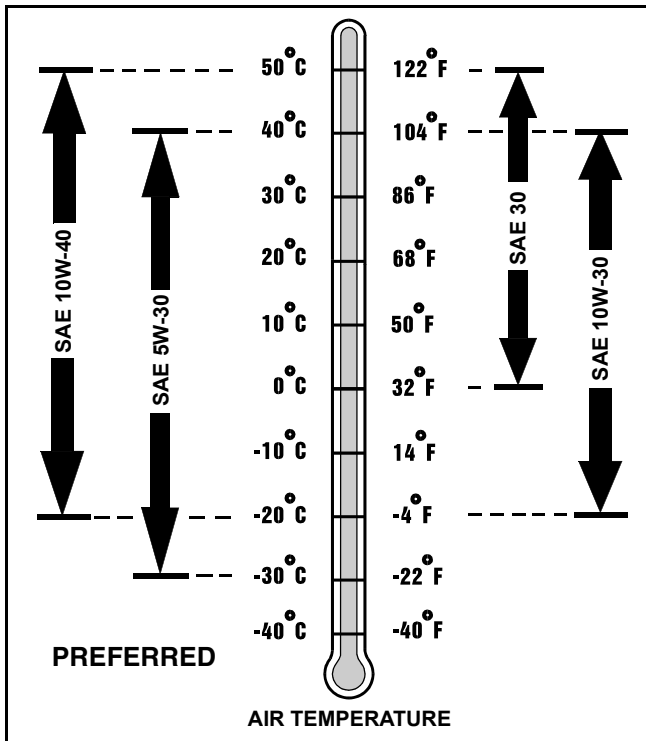

## Alternative Lubricants

Use of alternative lubricants could cause reduced life of the component.

If alternative lubricants are to be used, it is recommended that the factory fill be thoroughly removed before switching to any alternative lubricant.

## Synthetic Lubricants

Synthetic lubricants may be used in John Deere equipment if they meet the applicable performance requirements (industry classification and/or military specification) as shown in this manual.

The recommended air temperature limits and service or lubricant change intervals should be maintained as shown in the operator's manual, unless otherwise stated on lubricant label.

Avoid mixing different brands, grades, or types of oil. Oil manufacturers blend additives in their oils to meet certain specifications and performance requirements. Mixing different oils can interfere with the proper functioning of these additives and degrade lubricant performance.

## Lubricant Storage

All machines operate at top efficiency only when clean lubricants are used. Use clean storage containers to handle all lubricants. Store them in an area protected from dust, moisture, and other contamination. Store drums on their sides. Make sure all containers are properly marked as to their contents. Dispose of all old, used containers and their contents properly.

## Mixing of Lubricants

In general, avoid mixing different brands or types of lubricants. Manufacturers blend additives in their lubricants to meet certain specifications and performance requirements. Mixing different lubricants can interfere with the proper functioning of these additives and lubricant properties which will downgrade their intended specified performance.

## Oil Filters

**IMPORTANT: Avoid damage! Filtration of oils is critical to proper lubrication performance. Always change filters regularly.**

The following John Deere oil filters are PREFERRED:

- AUTOMOTIVE AND LIGHT TRUCK ENGINE OIL FILTERS.

Most John Deere filters contain pressure relief and anti-drainback valves for better engine protection.

Other oil filters may be used if above recommended John Deere oil filters are not available, provided they meet the following specification:

- ASTB TESTED IN ACCORDANCE WITH SAE J806.

# SPECIFICATIONS AND INFORMATION SERIAL NUMBER LOCATIONS

## Serial Number Locations

### Product Serial Number

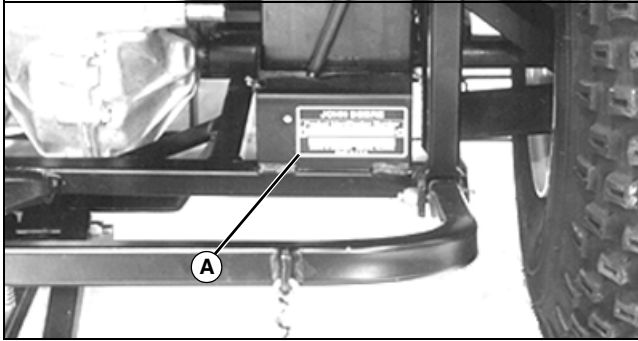

M83160

The product identification number (A) is located on the rear right side frame.

### Engine Serial Number

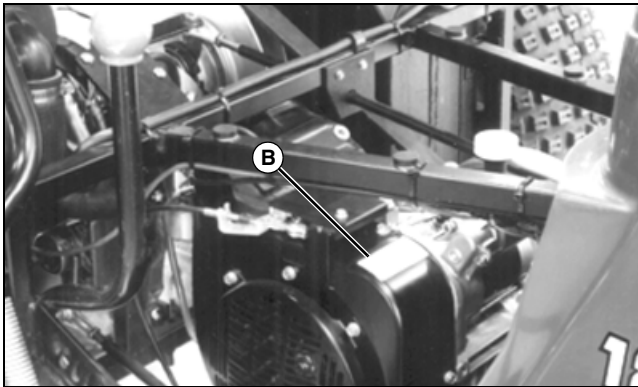

M83161

Engine serial number (B) is located on the side of the engine housing.

### Carburetor Serial Number

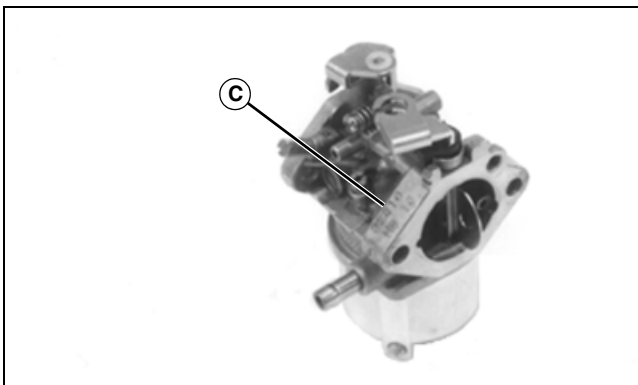

M83186

Carburetor serial number (C) is located on the top of the carburetor, above the fuel inlet.

### Transaxle Serial Number

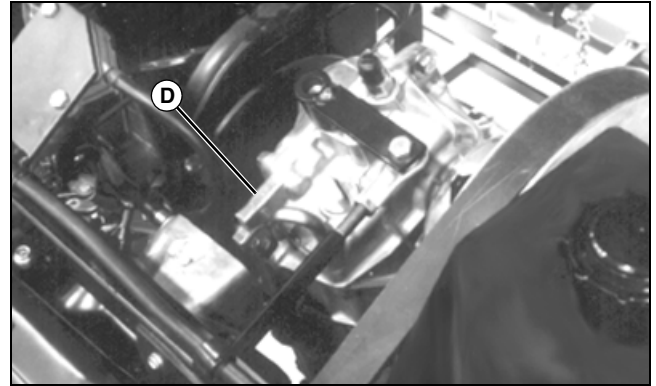

M83159

Transaxle serial number (D) is located on the top of the transaxle.

### Optional Hydraulic Pump Serial Number

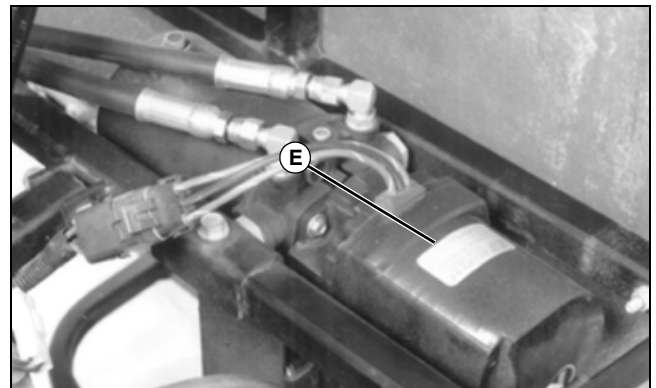

M80702

Hydraulic pump product identification number (E) is located on the top of the pump.

# **SPECIFICATIONS AND INFORMATION SERIAL NUMBER LOCATIONS**

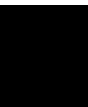

# ENGINE - GAS TABLE OF CONTENTS

## Table of Contents

### Specifications .....25

General Specifications .....	25
Fuel System Specifications .....	25
Test and Adjustment Specifications .....	25
Repair Specifications.....	26
Torque Specifications (Alphabetical).....	28
Special or Essential Tools .....	29
Other Materials.....	30

### Diagnostics .....31

Engine Will Not Start .....	31
-----------------------------	----

### Tests and Adjustments .....33

Adjust Throttle Cable.....	33
Adjust Choke Cable.....	33
Adjust Governor .....	34
Adjust Fast Idle Speed .....	34
Adjust Slow Idle Speed .....	35
Test Compression .....	36
Adjust Valve Clearance.....	37
Check Automatic Compression Release (ACR) .....	37
Test Crankcase Vacuum .....	38
Test Engine Oil Pressure .....	38
Test Fuel Pump .....	39
Check Crankshaft End Play .....	40
Test Spark.....	41
Adjust Spark Plug Gap.....	41

### Repair.....43

Remove and Install Fuel Tank.....	43
Remove and Install Accelerator Cable .....	43
Remove and Install Choke Cable.....	44
Remove and Install Muffler.....	45
Remove and Install Air Cleaner.....	45
Remove and Install Fuel Pump .....	46
Remove and Install Engine .....	46
Remove and Install Carburetor .....	47
Disassemble and Assemble Carburetor.....	49
Clean, Inspect, and Rebuild Carburetor .....	50
Service Breather Valve.....	50
Remove and Install Blower Housing .....	51
Remove and Install Flywheel .....	51
Remove and Install Rocker Arm.....	52
Remove and Install Cylinder Head.....	53
Disassemble and Assemble Cylinder Head .....	53
Inspect Cylinder Head .....	54

Replace Valve Guide Bushing .....	56
Inspect and Repair Valves.....	57
Remove and Install Crankcase Cover .....	59
Remove and Install Piston, Rings, and Rod .....	59
Disassemble and Assemble Piston and Connecting Rod.....	60
Inspect Piston and Connecting Rod .....	61
Ring End Gap .....	62
Analyze Piston Ring Wear .....	63
Analyze Piston Wear .....	64
Analyze Crankshaft and Connecting Rod Wear.....	65
Camshaft and Tappets .....	65
Remove and Install Reciprocating Balancer .....	67
Disassemble and Assemble Reciprocating Balancer .....	68
Inspect Reciprocating Balancer .....	68
Replace Reciprocating Balancer Bushing ...	69
Remove, Inspect, and Install Crankshaft and Main Bearings.....	69
Adjust Crankshaft End Play .....	71
Replace Crankshaft Oil Seal (Flywheel End).....	71
Replace Crankshaft Oil Seal (PTO End) .....	72
Analyze Crankshaft and Connecting Rod Wear.....	72
Cylinder Block.....	72
Hone Cylinder Bore .....	73
Resize Cylinder Bore.....	73
Oil Pump .....	74
Inspect Oil Pump .....	74
Remove and Install Oil Filter Manifold.....	75
Inspect and Replace Governor Shaft.....	75
Remove and Install Stator .....	76
Armature With Coil.....	76
Replace Ignition Module .....	77
Analyze Starting Motor .....	77
Test No-Load Amperage .....	77
Disassemble and Assemble Starting Motor .....	78
Inspect and Test Starting Motor.....	79

# ENGINE - GAS TABLE OF CONTENTS

---

---



# ENGINE - GAS SPECIFICATIONS

## Specifications

### General Specifications

Make	John Deere "K" Series
Type	Gasoline
Model	FE290D-AS11
Aspiration	Natural
Cylinders	1
Displacement	286 mL (17.5 cu in.)
Stroke/Cycle	4-Cycle
Bore	78 mm (3.070 in.)
Stroke	60 mm (2.360 in.)
Compression Ratio	8.4:1
Valving	Overhead valves
Lubrication	Pressurized
Oil Filter	Full flow filter, spin on
Engine Oil Capacity	1.30 L (2.75 pt)
Cooling System	Air cooled
Air Cleaner	Heavy duty with replaceable filter element
Muffler	Horizontal discharge below frame

### Fuel System Specifications

Fuel Tank Location	Behind driver, left side
Fuel Tank Capacity	13.25 L (3.5 gal)
Fuel	Unleaded gasoline (minimum 87 octane)
Fuel Pump Location	On right side of engine
Fuel Delivery	Side draft carburetor
Fuel Filter	Replaceable, in-line

### Test and Adjustment Specifications

Choke Knob-to-Cable-Mount Clearance	2-3 mm (0.08-0.12 in.)
Carburetor SLOW Idle Mixture Screw Initial Setting	1-3/8 in. turns
Throttle Control Arm SLOW Idle Stop Screw Setting	1175 ± 75 rpm
Carburetor SLOW Idle Stop Screw Setting	50 rpm less than throttle control arm SLOW idle stop screw setting
Throttle Control Arm FAST Idle Stop Screw Setting	3100 ± 75 rpm
Minimum Cylinder Compression Pressure at Operating Temperature	393 kPa (57 psi)
Minimum Crankcase Vacuum	30 mm (1.2 in.) water movement at fast idle
Minimum Engine Oil Pressure at 3800 RPM	310 kPa (45 psi)
Fuel Pump Minimum Pressure	6.120 kPa (0.90 psi)
Fuel Pump Minimum Flow	80 mL/15 seconds (2.7 oz/15 seconds)
Starter No-Load Amperage (Maximum)	50 amps
Starter No-Load RPM (Minimum)	6000 rpm
Armature With Coil Resistance Between Primary Lead and Coil	0.67-1.10 ohms
Armature With Coil Resistance Between Spark Plug Cap and Core	6-10 ohms
Armature Air Gap	0.20-0.30 mm (0.008-0.012 in.)

# ENGINE - GAS SPECIFICATIONS

Product: John Deere 1200A Bunker and Field Vehicle Service Repair Technical Manual

Full Download: <https://www.bobmanualstore.com/downloads/john-deere-1200a-bunker-and-field-vehicle-service-repair-technical-manual/>

Spark Plug Gap	0.30 mm (0.012 in.)
Valve Clearance (Cold)	0.125-0.025 mm (0.004-0.006 in.)
Intake and Exhaust Valve Adjustment Interval	300 hours
Minimum Exhaust Valve ACR Movement	0.6 mm (0.020 in.)
Maximum Exhaust Valve ACR Movement	1.65 mm (0.065 in.)
ACR Release RPM	approximately 900 rpm
Starter Brush Length (Minimum)	6 mm (0.240 in.)

## Repair Specifications

### Rocker Arm

Shaft OD (Minimum)	11.95 mm (0.470 in.)
Bearing ID (Maximum)	12.07 mm (0.475 in.)

### Push Rod

Maximum Bend	0.3 mm (0.012 in.)
--------------	--------------------

### Valves and Springs

Valve Spring Free Length (Minimum)	11.95 mm (1.289 in.)
Valve Guide ID (Maximum)	7.065 mm (0.2781 in.)
Finished Valve Guide ID (Reamed)	7.000-7.015 mm (0.2756-0.2762 in.)
Valve Stem Bend (Maximum)	0.03 mm (0.0012 in.)
Intake Valve Stem OD (Wear Limit)	6.930 mm (0.2728 in.)
Exhaust Valve Stem OD (Wear Limit)	6.915 mm (0.2722 in.)

### Valve Seat

Valve Seat Width	0.50-1.10 mm (0.020-0.043 in.)
Valve Seat and Face Angle	45°
Valve Face Margin (Minimum)	0.60 mm (0.020 in.)
Valve Seat Narrowing Angle	30°
Valve Clearance (Cold)	0.125 ± 0.025 mm (0.005 ± 0.001 in.)

### Cylinder Head

Cylinder Head Flatness (Maximum Distortion)	0.05 mm (0.002 in.)
---	---------------------

### Crankcase

Oil Capacity	1.3 L (2.7 pt.)
Maximum Crankcase Main Bearing ID	30.08 mm (1.184 in.)
End Play	0.09-0.22 mm (0.004-0.009 in.)
Crankshaft Oil Seal Depth (PTO End)	4 mm (0.158 in.)
Governor Mounting Shaft Height (Top of Shaft-to-Cover)	32.2-32.8 mm (1.267-1.291 in.)
Governor Shaft Oil Seal Depth	1.42 mm (0.056 in.)

### Camshaft

Minimum PTO and Flywheel Journal OD	22.93 mm (0.903 in.)
Minimum Lobe Height	32.70 mm (1.287 in.)
Maximum Cylinder Block and Cover Bearing ID	23.06 mm (0.908 in.)

Sample manual. Download All 257 pages at:

<https://www.bobmanualstore.com/downloads/john-deere-1200a-bunker-and-field-vehicle-service-repair-technical-manual/>  
Engine - Gas Specifications - 26