

Product: John Deere 1800 Utility Vehicle Service Repair Technical Manual
Full Download: <https://www.bobmanualstore.com/downloads/john-deere-1800-utility-vehicle-service-repair-technical-manual/>

1800 Utility Vehicle

Sample Manual. Download All 452 pages at
<https://www.bobmanualstore.com/downloads/john-deere-1800-utility-vehicle-service-repair-technical-manual/>

TW1527 (10APR92)

LITHO IN U.S.A.
ENGLISH

Introduction

Product: John Deere 1800 Utility Vehicle Service Repair Technical Manual

Full Download: <https://www.bobmanualstore.com/downloads/john-deere-1800-uti>

[utility-vehicle-service-repair-technical-manual/](https://www.bobmanualstore.com/downloads/john-deere-1800-utility-vehicle-service-repair-technical-manual/)

FOREWORD

This manual is written for an experienced technician. Essential tools required in performing certain service work are identified in this manual and are recommended for use.

LIVE WITH SAFETY: Read the safety messages in the introduction of this manual and the cautions presented throughout the text of the manual.

PThis is the safety-alert symbol. When you see this symbol on the machine or in this manual, be alert to the potential for personal injury.

Technical manuals are divided in two parts: repair and diagnostics. Repair sections tell how to repair the components. Diagnostic sections help you identify the majority of routine failures quickly.

Information is organized in groups for the various components requiring service instruction. At the beginning of each group are summary listings of all applicable essential tools, service equipment and tools, other materials needed to do the job, service parts kits, specifications, wear tolerances, and torque values.

Binders, binder labels, and tab sets can be ordered by John Deere dealers direct from the John Deere Distribution Service Center.

This manual is part of a total product support program.

FOS MANUALS—REFERENCE

TECHNICAL MANUALS—MACHINE SERVICE

COMPONENT MANUALS—COMPONENT SERVICE

Fundamentals of Service (FOS) Manuals cover basic theory of operation, fundamentals of troubleshooting, general maintenance, and basic type of failures and their causes. FOS Manuals are for training new personnel and for reference by experienced technicians.

Technical Manuals are concise guides for specific machines. Technical manuals are on-the-job guides containing only the vital information needed for diagnosis, analysis, testing, and repair.

Component Technical Manuals are concise service guides for specific components. Component technical manuals are written as stand-alone manuals covering multiple machine applications.

Sample manual. Download All 432 pages at:

MX,TM1527,IFC -19-14APR92

<https://www.bobmanualstore.com/downloads/john-deere-1800-utility-vehicle-service-repair-technical-manual/>

TM1527 (NOV-1992)

1800 Utility Vehicle

VEHICLE

161095

Contents

SECTION 10—GENERAL INFORMATION

- Group 05—Safety
- Group 10—General Specifications
- Group 15—Repair Specifications
- Group 20—Fuels and Lubricants
- Group 25—Serial Number Locations
- Group 30—Features and Attachments

SECTION 20—Engine Repair

- Group 05—Engine

SECTION 30—FUEL AND AIR REPAIR

- Group 05—Fuel System
- Group 10—Air System

SECTION 40—ELECTRICAL REPAIR

- Group 05—Electrical System
- Group 10—Starter
- Group 15—Ignition and Charging System

SECTION 50—POWER TRAIN REPAIR

- Group 05—Transmission
- Group 10—Two-Speed Differential
- Group 15—Transmission Control Linkage
- Group 20—Axles
- Group 25—Drive Shaft

SECTION 60—STEERING AND BRAKE REPAIR

- Group 05—Steering Valve
- Group 10—Steering Cylinder
- Group 15—Brakes

SECTION 80—MISCELLANEOUS

- Group 05—Front/Rear Wheel Bearing Repair

SECTION 210—OPERATIONAL CHECKOUT PROCEDURES

- Group 05—Test and Adjustment Specifications
- Group 10—Operational Checkout Procedures

SECTION 220—ENGINE OPERATION, TESTS, AND ADJUSTMENTS

- Group 05—Component Location Information
- Group 10—Theory of Operation

- Group 15—Diagnosis, Tests, & Adjustments

SECTION 230—FUEL OPERATION, TESTS, AND ADJUSTMENTS

- Group 05—Component Location
- Group 10—Theory of Operation

SECTION 240—ELECTRICAL OPERATION, TESTS, AND ADJUSTMENTS

- Group 05—Component Location Information
- Group 10—Theory of Operation
- Group 15—Diagnosis, Tests, & Adjustments
- Group 20—Wiring Schematics

SECTION 250—POWER TRAIN OPERATION, TESTS, AND ADJUSTMENTS

- Group 05—Component Location
- Group 10—Theory of Operation
- Group 15—Diagnosis

SECTION 260—STEERING AND BRAKES OPERATION, TESTS, & ADJUSTMENTS

- Group 05—Component Location
- Group 10—Theory of Operation
- Group 15—Diagnosis, Tests, & Adjustments

Index

All information, illustrations and specifications in this manual are based on the latest information available at the time of publication. The right is reserved to make changes at any time without notice.

TM1527-19-10APR92

COPYRIGHT© 1991
DEERE & COMPANY
Moline, Illinois
All rights reserved
A John Deere ILLUSTRATION™ Manual

Contents

10

20

30

40

50

60

80

210

220

230

240

250

260

INDX

Contents

240

250

260

INDX

Section 10 GENERAL INFORMATION

Contents

	Page
Group 05—Safety	10-05-1
Group 10—General Specifications	
Machine Specifications	10-10-1
Group 15—Repair Specifications	
Repair Specifications	10-15-1
Repair Specifications	10-15-2
Group 20—Fuels and Lubricants	
Fuel	10-20-1
Fuel	10-20-1
Gasoline Engine Oil	10-20-2
Engine Coolant	10-20-2
Hydrostatic Drive Oil	10-20-3
Extreme Pressure or Multipurpose Grease	10-20-3
Lubricant Storage	10-20-4
Alternative Lubricants	10-20-4
Group 25—Serial Number Locations	
Record Product Identification Number . . .	10-25-1
Record Engine Serial Number	10-25-1
Record Differential Serial Number	10-25-1
Record Hydrostatic Transmission Serial Number	10-25-2
Group 30—Features and Attachments	
Standard Features	10-30-2

RECOGNIZE SAFETY INFORMATION

This is the safety-alert symbol. When you see this symbol on your machine or in this manual, be alert to the potential for personal injury.

Follow recommended precautions and safe operating practices.

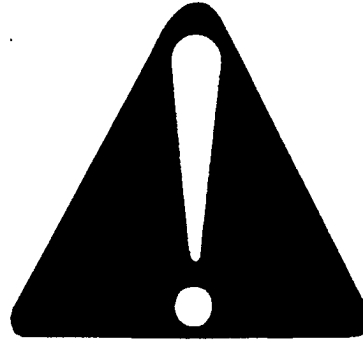

DX,ALERT -19-04JUN90

10
05
1
-UN-07DEC88
T81389

UNDERSTAND SIGNAL WORDS

A signal word—DANGER, WARNING, or CAUTION—is used with the safety-alert symbol. DANGER identifies the most serious hazards.

DANGER or WARNING safety signs are located near specific hazards. General precautions are listed on CAUTION safety signs. CAUTION also calls attention to safety messages in this manual.



DX,SIGNAL -19-09JAN92

-19-30SEP88
TS187

FOLLOW SAFETY INSTRUCTIONS

Carefully read all safety messages in this manual and on your machine safety signs. Keep safety signs in good condition. Replace missing or damaged safety signs. Be sure new equipment components and repair parts include the current safety signs. Replacement safety signs are available from your John Deere dealer.

Learn how to operate the machine and how to use controls properly. Do not let anyone operate without instruction.

Keep your machine in proper working condition. Unauthorized modifications to the machine may impair the function and/or safety and affect machine life.

If you do not understand any part of this manual and need assistance, contact your John Deere dealer.



DX,READ -19-04JUN90

-UN-23AUG88
TS201

10
05
2

HANDLE FLUIDS SAFELY—AVOID FIRES

When you work around fuel, do not smoke or work near heaters or other fire hazards.

Store flammable fluids away from fire hazards. Do not incinerate or puncture pressurized containers.

Make sure machine is clean of trash, grease, and debris.

Do not store oily rags; they can ignite and burn spontaneously.



DX,FLAME -19-04JUN90

-UN-23AUG88
TS227

PREVENT BATTERY EXPLOSIONS

Keep sparks, lighted matches, and open flame away from the top of battery. Battery gas can explode.

Never check battery charge by placing a metal object across the posts. Use a volt-meter or hydrometer.

Do not charge a frozen battery; it may explode. Warm battery to 16°C (60°F).



DX,SPARKS -19-04JUN90

-UN-23AUG88
TS204

PREPARE FOR EMERGENCIES

Be prepared if a fire starts.

Keep a first aid kit and fire extinguisher handy.

Keep emergency numbers for doctors, ambulance service, hospital, and fire department near your telephone.

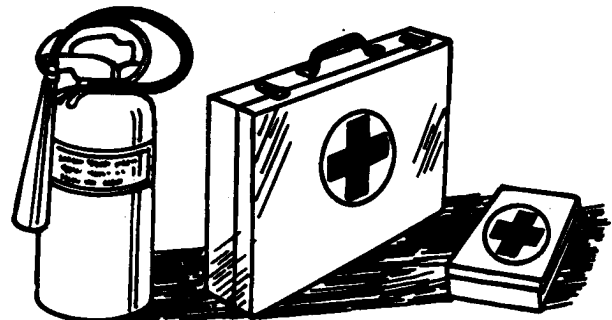

DX,FIRE2 -19-04JUN90

-UN-23AUG88
TS291

PREVENT ACID BURNS

Sulfuric acid in battery electrolyte is poisonous. It is strong enough to burn skin, eat holes in clothing, and cause blindness if splashed into eyes.

Avoid the hazard by:

1. Filling batteries in a well-ventilated area.
2. Wearing eye protection and rubber gloves.
3. Avoiding breathing fumes when electrolyte is added.
4. Avoiding spilling or dripping electrolyte.
5. Use proper jump start procedure.

If you spill acid on yourself:

1. Flush your skin with water.
2. Apply baking soda or lime to help neutralize the acid.
3. Flush your eyes with water for 10—15 minutes. Get medical attention immediately.

If acid is swallowed:

1. Drink large amounts of water or milk.
2. Then drink milk of magnesia, beaten eggs, or vegetable oil.
3. Get medical attention immediately.

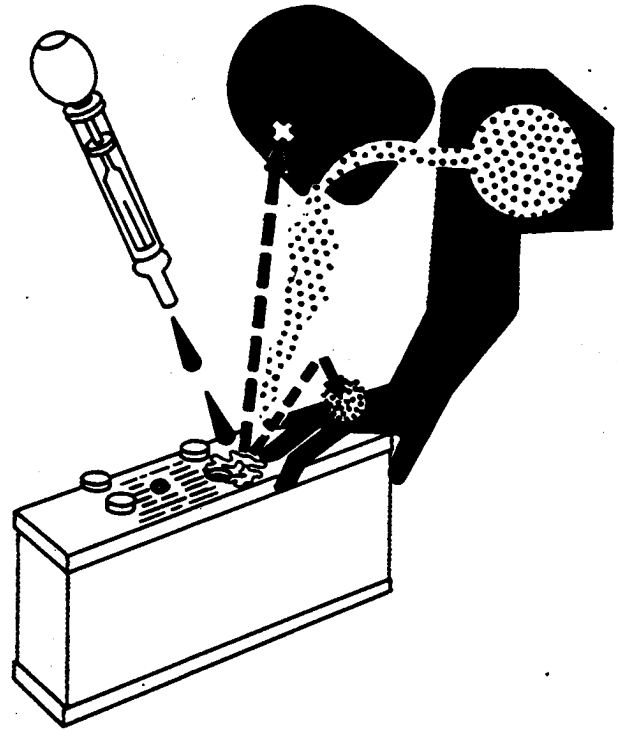

DX,POISON -19-04JUN90

10
3
95
-UN-23AUG88
T5203

SERVICE COOLING SYSTEM SAFELY

Explosive release of fluids from pressurized cooling system can cause serious burns.

Shut off engine. Only remove filler cap when cool enough to touch with bare hands. Slowly loosen cap to first stop to relieve pressure before removing completely.



DX,RCAP -19-04JUN90

-UN-23AUG88
T5281

10
05
4

PARK MACHINE SAFELY

Before working on the machine:

- Lower all equipment to the ground.
- Stop the engine and remove the key.
- Disconnect the battery ground strap.
- Hang a "DO NOT OPERATE" tag in operator station.

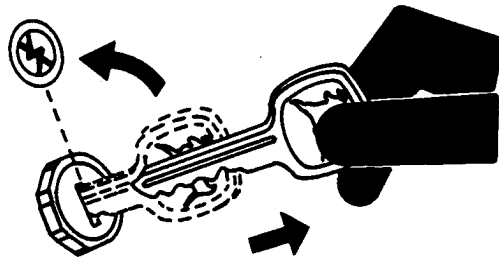

DX,PARK -19-04JUN90

TS230 -UN-24MAY89

SUPPORT MACHINE PROPERLY

Always lower the attachment or implement to the ground before you work on the machine. If you must work on a lifted machine or attachment, securely support the machine or attachment.

Do not support the machine on cinder blocks, hollow tiles, or props that may crumble under continuous load. Do not work under a machine that is supported solely by a jack. Follow recommended procedures in this manual.

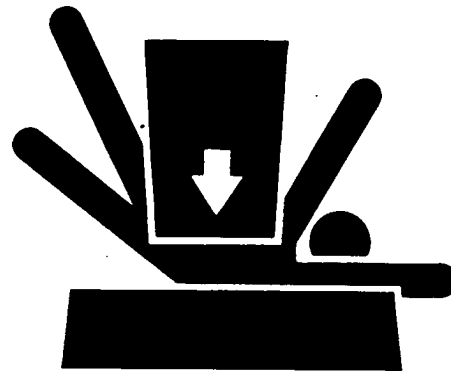

DX,LOWER -19-04JUN90

TS229 -UN-23AUG88

WEAR PROTECTIVE CLOTHING

Wear close fitting clothing and safety equipment appropriate to the job.

Prolonged exposure to loud noise can cause impairment or loss of hearing.

Wear a suitable hearing protective device such as earmuffs or earplugs to protect against objectionable or uncomfortable loud noises.

Operating equipment safely requires the full attention of the operator. Do not wear radio or music headphones while operating machine.

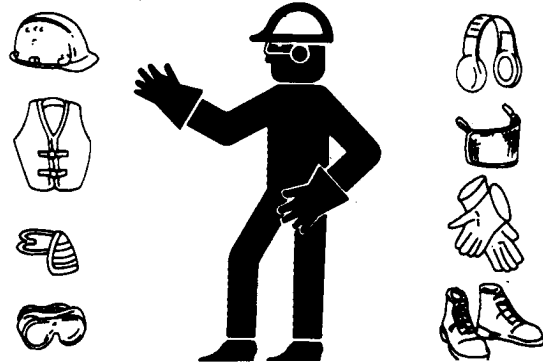

DX,WEAR -19-10SEP90

TS206 -UN-23AUG88

WORK IN CLEAN AREA

Before starting a job:

- Clean work area and machine.
- Make sure you have all necessary tools to do your job.
- Have the right parts on hand.
- Read all instructions thoroughly; do not attempt shortcuts.

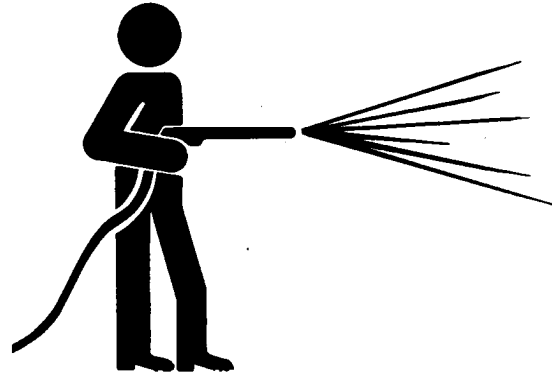

DX,CLEAN -19-04JUN90

T6642EJ -UN-18OCT88

51510

SERVICE MACHINES SAFELY

Tie long hair behind your head. Do not wear a necktie, scarf, loose clothing, or necklace when you work near machine tools or moving parts. If these items were to get caught, severe injury could result.

Remove rings and other jewelry to prevent electrical shorts and entanglement in moving parts.

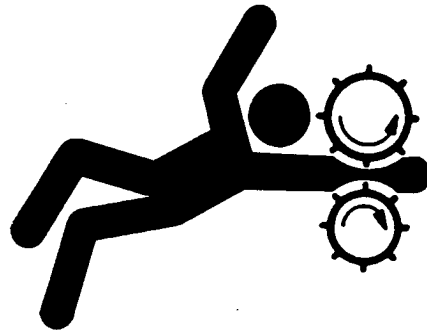

DX,LOOSE -19-04JUN90

TS228 -UN-23AUG88

WORK IN VENTILATED AREA

Engine exhaust fumes can cause sickness or death. If it is necessary to run an engine in an enclosed area, remove the exhaust fumes from the area with an exhaust pipe extension.

If you do not have an exhaust pipe extension, open the doors and get outside air into the area.

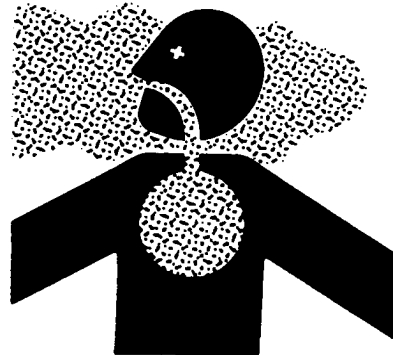

DX,AIR -19-04JUN90

TS220 -UN-23AUG88

ILLUMINATE WORK AREA SAFELY

Illuminate your work area adequately but safely. Use a portable safety light for working inside or under the machine. Make sure the bulb is enclosed by a wire cage. The hot filament of an accidentally broken bulb can ignite spilled fuel or oil.

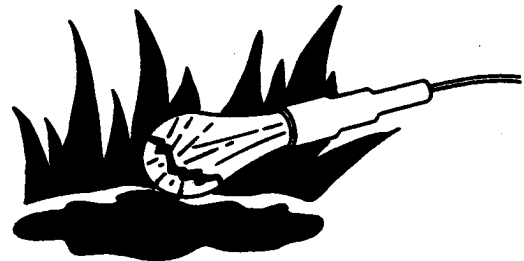

DX,LIGHT -19-04JUN90

TS223 -UN-23AUG88

10
05
6

REPLACE SAFETY SIGNS

Replace missing or damaged safety signs. See the machine operator's manual for correct safety sign placement.

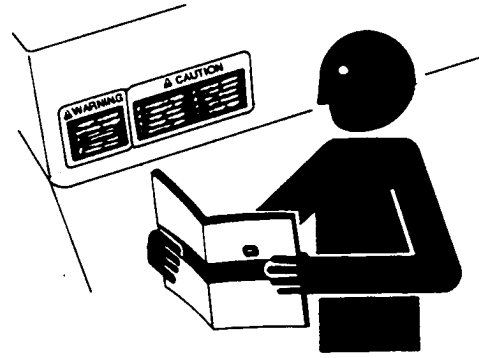

DX,SIGNS1 -19-04JUN90

TS201 -UN-23AUG88

USE PROPER LIFTING EQUIPMENT

Lifting heavy components incorrectly can cause severe injury or machine damage.

Follow recommended procedure for removal and installation of components in the manual.

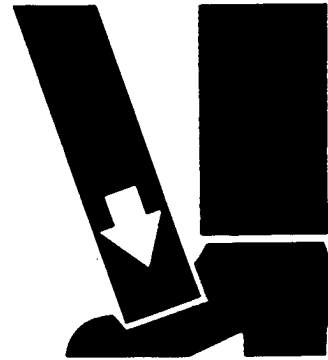

DX,LIFT -19-04JUN90

TS226 -UN-23AUG88

SERVICE TIRES SAFELY

Explosive separation of a tire and rim parts can cause serious injury or death.

Do not attempt to mount a tire unless you have the proper equipment and experience to perform the job.

Always maintain the correct tire pressure. Do not inflate the tires above the recommended pressure. Never weld or heat a wheel and tire assembly. The heat can cause an increase in air pressure resulting in a tire explosion. Welding can structurally weaken or deform the wheel.

When inflating tires, use a clip-on chuck and extension hose long enough to allow you to stand to one side and NOT in front of or over the tire assembly. Use a safety cage if available.

Check wheels for low pressure, cuts, bubbles, damaged rims or missing lug bolts and nuts.



DX,TIRECP -19-24AUG90

TS952 -UN-12APR90

AVOID HARMFUL ASBESTOS DUST

Avoid breathing dust that may be generated when handling components containing asbestos fibers. Inhaled asbestos fibers may cause lung cancer.

Components in products that may contain asbestos fibers are brake pads, brake band and lining assemblies, clutch plates, and some gaskets. The asbestos used in these components is usually found in a resin or sealed in some way. Normal handling is not hazardous as long as airborne dust containing asbestos is not generated.

Avoid creating dust. Never use compressed air for cleaning. Avoid brushing or grinding material containing asbestos. When servicing, wear an approved respirator. A special vacuum cleaner is recommended to clean asbestos. If not available, apply a mist of oil or water on the material containing asbestos.

Keep bystanders away from the area.

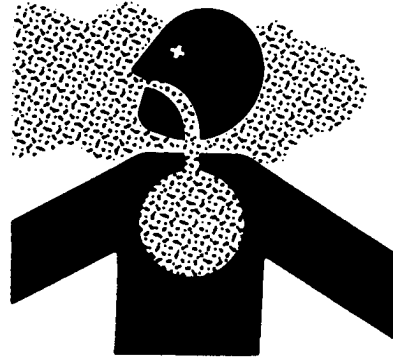

DX,DUST -19-15MAR91

TS220 -UN-23AUG88

10
05
7

AVOID HEATING NEAR PRESSURIZED FLUID LINES

Flammable spray can be generated by heating near pressurized fluid lines, resulting in severe burns to yourself and bystanders. Do not heat by welding, soldering, or using a torch near pressurized fluid lines or other flammable materials. Pressurized lines can be accidentally cut when heat goes beyond the immediate flame area.



DX,TORCH -19-05OCT90

TS953 -UN-15MAY90

10
05
8

REMOVE PAINT BEFORE WELDING OR HEATING

Avoid potentially toxic fumes and dust.

Hazardous fumes can be generated when paint is heated by welding, soldering, or using a torch.

Do all work outside or in a well ventilated area. Dispose of paint and solvent properly.

Remove paint before welding or heating:

- If you sand or grind paint, avoid breathing the dust. Wear an approved respirator.
- If you use solvent or paint stripper, remove stripper with soap and water before welding. Remove solvent or paint stripper containers and other flammable material from area. Allow fumes to disperse at least 15 minutes before welding or heating.



TS220 -UN-23AUG88

DX,PAINT -19-04JUN90

USE PROPER TOOLS

Use tools appropriate to the work. Makeshift tools and procedures can create safety hazards.

Use power tools only to loosen threaded parts and fasteners.

For loosening and tightening hardware, use the correct size tools. DO NOT use U.S. measurement tools on metric fasteners. Avoid bodily injury caused by slipping wrenches.

Use only service parts meeting John Deere specifications.



TS779 -UN-08NOV89

DX,REPAIR -19-04JUN90

DISPOSE OF WASTE PROPERLY

Improperly disposing of waste can threaten the environment and ecology. Potentially harmful waste used with John Deere equipment include such items as oil, fuel, coolant, brake fluid, filters, and batteries.

Use leakproof containers when draining fluids. Do not use food or beverage containers that may mislead someone into drinking from them.

Do not pour waste onto the ground, down a drain, or into any water source.

Air conditioning refrigerants escaping into the air can damage the Earth's atmosphere. Government regulations may require a certified air conditioning service center to recover and recycle used air conditioning refrigerants.

Inquire on the proper way to recycle or dispose of waste from your local environmental or recycling center, or from your John Deere dealer.

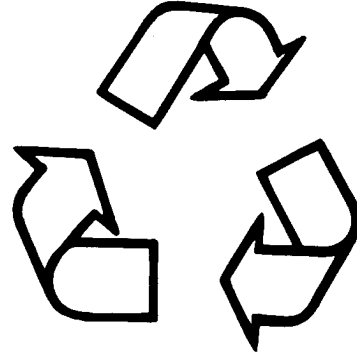

DX,DRAIN -19-09AUG91

9510
-UN-26NOV90
TS1133

LIVE WITH SAFETY

Before returning machine to customer, make sure machine is functioning properly, especially the safety systems. Install all guards and shields.



DX,LIVE -19-04JUN90

-19-07OCT88
TS231

10
05
10

MACHINE SPECIFICATIONS

ENGINE

Make Kawasaki
 Type Gasoline
 Model FD620D
 Horsepower 13.4 kW (18 hp)
 Number of Cylinders Two 90° V-Twin
 Cycle Four
 Displacement 617 cc (37.7 cu. in.)
 Bore 76 mm (2.99 in.)
 Stroke 68 mm (2.66 in.)
 Compression Ratio 9.0:1
 Speed, Fast (no load) 3600 ± 50 rpm
 Speed, idle (no load) 1550 ± 50 rpm
 Lubrication Full Pressure
 Cooling System Water Pump/Radiator
 Oil Filter Full Flow Replaceable
 Air Cleaner Dry, replaceable primary and secondary elements

FUEL SYSTEM

Fuel Unleaded gasoline or leaded gasoline with an antiknock index of 87 or higher
 Fuel Filter Replaceable in-line filter
 Fuel Pump Electric

ELECTRICAL SYSTEM

Type 12 volt, negative ground
 Charging System Stator
 Capacity 20 amp Regulator
 Battery Size 430 CCA at -18°C (0° F), BCI-45, length 9.4 in., width 5.5 in., height 8.9 in.
 Battery Reserve Capacity at 25 amps 80 min.

INSTRUMENTATION

Speedometer Dash Mounted, In KPH and MPH readable to within ± .5 mph
 Hourmeter Dash Mounted, running with key in ON position
 Tachometer Dash Mounted, reading engine rpm
 Low Battery Indicator Light Dash Mounted, warning low battery voltage
 Engine Coolant Temp. Indicator Dash Mounted, warning high coolant temperature
 Engine Oil Pressure Indicator Light Dash Mounted, warning low oil pressure
 Choke Dash Mounted, for cold starting
 Ignition Switch Dash Mounted

POWER TRAIN

Transmission Hydrostatic U-type
 Manufacturer Sauer Sundstrand 15 Series
 Number of Speeds Infinite
 Travel Speeds
 Forward 0-18 km/h (0-11.5 mph)
 Reverse 0-9.7 km/h (0-6 mph)
 Differential Peerless 2-Speed (without Differential Lock and with Park Lock)

10
10
2

MACHINE SPECIFICATIONS—CONTINUED

STEERING/BRAKES

Steering Power, Hydrostatic
 Brakes Independent, shoe and drum. Rear Axle Mounted
 Park Brake 1 Motion Release

CAPACITIES

Fuel Tank Translucent With No Graduations,
 30 L (8 gallon) capacity
 Transmission 7.1 L (7.5 U.S. qt)
 Cooling System 3.5 L (3.8 U.S. qt)
 Crankcase (w/ filter) 2.1 L (4.44 U.S. qt)
 Crankcase (w/o filter) 1.9 L (4.0 U.S. qt)

TIRES

Front Tire Size/Type 23 x 10.5 - 12 Softrac
 Front Tire Operating PSI (8-12 psi)
 Rear Tire Size/Type 26 x 12.0 - 12 Softrac
 Rear Tire Operating PSI (8-12 psi)

DIMENSIONS (BASE VEHICLE)

Wheel Base 61.5 in. (1562 mm)
 Front Tread Width (center line) 54 in. (1372 mm)
 Rear Tread Width (center line) 54 in. (1372 mm)
 Outside Turning Radius 24 ft(7.32 m)
 Inside Turning Radius 23.4 ft (7.11 m)
 Ground Clearance 7 in. (178 mm)
 Overall Length 120 in. (3048 mm)
 Overall Width 65.6 in. (1667 mm)
 Overall Height 50.5 in. (1283 mm)
 Overall Weight* 1325 lbs (602 kg)
 Front Axle Weight* 857 lbs (390 kg)
 Rear Axle Weight* 468 lbs (213 kg)
 Noise Levels
 Low Idle at Operators Ear
 High Idle at Operators Ear

VEHICLE USAGE (BASE VEHICLE WITH SPRAYER)

Spraying Speed ± tolerance 3-6 mph ± .5 mph
 Speed Reduction Up 10% Grade
 Transporting 2.3 mph (20% Reduction)
 Spraying6 - 1.5 mph (20% Reduction)
 Max. Slope During Spraying Operation 20% (11.3 Degree)
 Satisfies Stability Standards ANSI B71.4

*ALL WEIGHTS INCLUDE A 200 LB OPERATOR, FULL TANK OF FUEL, AND BATTERY.

REPAIR SPECIFICATIONS

Item	Measurement	Specification
SECTION 20 - ENGINE REPAIR		
For all engine repair specs-Use CTM39		
Engine-to-Frame Cap Screw	Torque	18 N·M (160 lb-in.)
Drive Shaft-to-Engine Cap Screw	Torque	35 N·M (27 lb-ft)
Cylinder Head Cap Screw	Torque	21 N·M (0.800 in.)
Outer Sheave Half-to-Flywheel Cap Screw	Torque	13 N·M (115 lb-in.)
Spark Plugs	Torque	20 N·M (177 lb-in.)

SECTION 30 - FUEL AND AIR REPAIR

For all carburetor repair specifications -
Use CTM39

Transfer Pump	Flow Pressure	207 mL (7 oz)/30 sec min. 19.6 kPa (0.196 bar) (2.8 psi)
-------------------------	-------------------------	-------------------------------------------------------------

SECTION 50 - POWER TRAIN REPAIR

TRANSMISSION

Swashplate	Full Movement	25 mm (1 in.)
Meter Shaft Bearing Race	Mounting surface to bearing race	5 mm (0.187 in.)
Spring Pin-to-Swashplate	Depth	6 mm (0.250 in.)
Valve Plate Needle Bearings	Top of bearing to cover surface	3 mm (0.109 in.)
Cover-to-Housing Cap Screws	Torque	35 N·m (28 lb-ft)
Hydraulic Line Fitting	Torque	24 N·m (215 lb-in.)
Transmission-to-Differential cap screws	Torque	45 N·m (35 lb-ft)

CHARGE PUMP

Pump-to-Transmission Cap Screws	Torque	70 N·m (50 lb-ft)
-------------------------------------------	------------------	-------------------

DIFFERENTIAL

Carrier-to-Holder Cap Screw	Torque	52 N·m (37 lb-ft)
Cover-to-Case Cap Screw	Torque	22 N·m (192 lb-in.)

AXLES

Axle-to-Differential Seal	Depth	3 mm (0.125 in.)
Axle-to-Differential Cap Screw	Torque	80 N·m (60 lb-ft)
Axle-to-Frame Cap Screw	Torque	106 N·m (78 lb-ft)

10
15
2

REPAIR SPECIFICATIONS—CONTINUED

Item	Measurement	Specification
SECTION 60 - STEERING AND BRAKE REPAIR		
STEERING		
Steering Wheel-to-column Nut	Torque	14 N·m (12 lb-in.)
Steering Valve		
Rotor-to-Stator	Maximum Clearance	0.08 N·m (0.003 in.)
Bushing	Depth below top of steering tube	2.5 mm (0.100 in.)
METERING ASSEMBLY-TO-VALVE		
Screw	Torque	1.4 N·m (12 lb-in.)
Steering Valve Nuts	Torque	30 N·m (22 lb-ft)
Relief Valve Plug	Torque	14 N·m (124 lb-in.)
Implement Relief Valve	Torque	14 N·m (124 lb-in.)
Steering Link-to-Axle Nut	Torque	75 N·m (55 lb-ft)
BRAKES		
Brake Plate-to-Frame Cap Screw	Torque	68 N·m (50 lb-ft)
Brake Drum-to-Axle Shaft Nut	Torque	115-156 N·m (85-115 lb-ft)
Hub-to-Drum Cap Screws	Torque	95 N·m (70 lb-ft)
FRONT AXLE		
Steering Link-to-Axle Nut	Torque	75 N·m (55 lb-ft)
Front Wheel Cap Screws	Torque	81-95 N·m (60-70 lb-ft)
Axle-to-Tie Rod End Nut	Torque	61 N·m (45 lb-ft)
Front Axle Mounting Bolt	Torque	668 N·m (150 lb-ft)

MX,1015HJ,1A -19-14APR92

SERVICE RECOMMENDATIONS FOR O-RING BOSS FITTINGS

STRAIGHT FITTING

1. Inspect O-ring boss seat for dirt or defects.
2. Lubricate O-ring with petroleum jelly. Place electrical tape over threads to protect O-ring. Slide O-ring over tape and into O-ring groove of fitting. Remove tape.
3. Tighten fitting to torque value shown on chart.

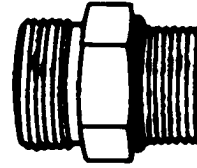

ANGLE FITTING

1. Back-off lock nut (A) and back-up washer (B) completely to head-end (C) of fitting.
2. Turn fitting into threaded boss until back-up washer contacts face of boss.
3. Turn fitting head-end counterclockwise to proper index (maximum of one turn).
4. Hold fitting head-end with a wrench and tighten locknut and back-up washer to proper torque value.

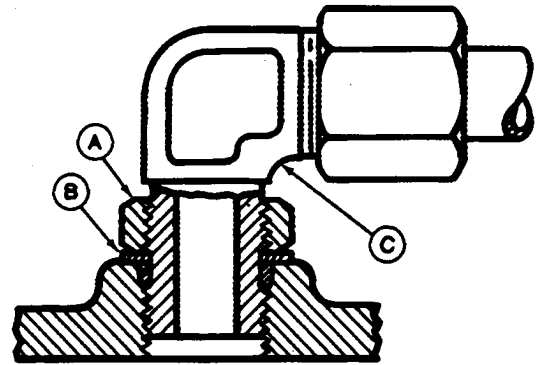

NOTE: Do not allow hoses to twist when tightening fittings.

TORQUE VALUE

Thread Size	N-m	lb-ft
3/8-24 UNF	8	6
7/16-20 UNF	12	9
1/2-20 UNF	16	12
9/16-18 UNF	24	18
3/4-16 UNF	46	34
7/8-14 UNF	62	46
1-1/16-12 UN	102	75
1-3/16-12 UN	122	90
1-5/16-12 UN	142	105
1-5/8-12 UN	190	140
1-7/8-12 UN	217	160

NOTE: Torque tolerance is $\pm 10\%$.

04T,90,K66 -19-21JAN92

10
15
3
-UN-18OCT88
T6249AE
-UN-18OCT88
T6520AB

METRIC BOLT AND CAP SCREW TORQUE VALUES

10
15
4

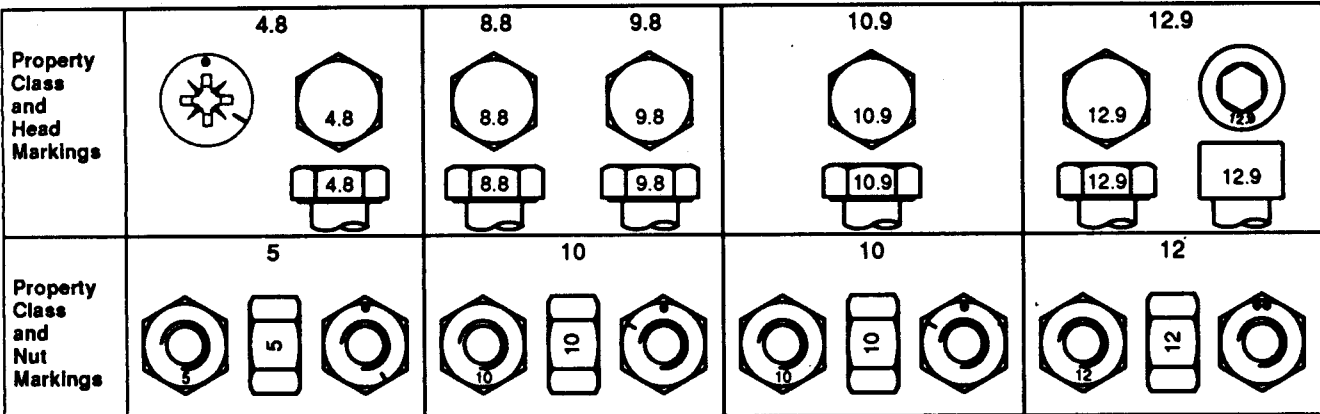

TS1163 -19-04/MAR91

Size	Class 4.8				Class 8.8 or 9.8				Class 10.9				Class 12.9			
	Lubricated ^a		Dry ^a		Lubricated ^a		Dry ^a		Lubricated ^a		Dry ^a		Lubricated ^a		Dry ^a	
	N-m	lb-ft	N-m	lb-ft	N-m	lb-ft	N-m	lb-ft	N-m	lb-ft	N-m	lb-ft	N-m	lb-ft	N-m	lb-ft
M6	4.8	3.5	6	4.5	9	6.5	11	8.5	13	9.5	17	12	15	11.5	19	14.5
M8	12	8.5	15	11	22	16	28	20	32	24	40	30	37	28	47	35
M10	23	17	29	21	43	32	55	40	63	47	80	60	75	55	95	70
M12	40	29	50	37	75	55	95	70	110	80	140	105	130	95	165	120
M14	63	47	80	60	120	88	150	110	175	130	225	165	205	150	260	190
M16	100	73	125	92	190	140	240	175	275	200	350	225	320	240	400	300
M18	135	100	175	125	260	195	330	250	375	275	475	350	440	325	560	410
M20	190	140	240	180	375	275	475	350	530	400	675	500	625	460	800	580
M22	260	190	330	250	510	375	650	475	725	540	925	675	850	625	1075	800
M24	330	250	425	310	650	475	825	600	925	675	1150	850	1075	800	1350	1000
M27	490	360	625	450	950	700	1200	875	1350	1000	1700	1250	1600	1150	2000	1500
M30	675	490	850	625	1300	950	1650	1200	1850	1350	2300	1700	2150	1600	2700	2000
M33	900	675	1150	850	1750	1300	220	1650	2500	1850	3150	2350	2900	2150	3700	2750
M36	1150	850	1450	1075	2250	1650	2850	2100	3200	2350	4050	3000	3750	2750	4750	3500

DO NOT use these values if a different torque value or tightening procedure is given for a specific application. Torque values listed are for general use only. Check tightness of fasteners periodically.

Make sure fasteners threads are clean and that you properly start thread engagement. This will prevent them from failing when tightening.









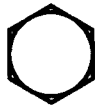

Shear bolts are designed to fail under predetermined loads. Always replace shear bolts with identical property class.

Tighten plastic insert or crimped steel-type lock nuts to approximately 50 percent of the dry torque shown in the chart, applied to the nut, not to the bolt head. Tighten toothed or serrated-type lock nuts to the full torque value.

Fasteners should be replaced with the same or higher property class. If higher property class fasteners are used, these should only be tightened to the strength of the original.

^a "Lubricated means coated with a lubricant such as engine oil, or fasteners with phosphate and oil coatings. "Dry means plain or zinc plated without any lubrication.

UNIFIED INCH BOLT AND CAP SCREW TORQUE VALUES

SAE Grade and Head Markings	1 or 2 ^b	5	5.1	5.2	8	8.2
	NO MARK 					
SAE Grade and Nut Markings	2	5		8		
	NO MARK 					

Size	Grade 1				Grade 2 ^b				Grade 5, 5.1, or 5.2				Grade 8 or 8.2			
	Lubricated ^a		Dry ^a		Lubricated ^a		Dry ^a		Lubricated ^a		Dry ^a		Lubricated ^a		Dry ^a	
	N-m	lb-ft	N-m	lb-ft	N-m	lb-ft	N-m	lb-ft	N-m	lb-ft	N-m	lb-ft	N-m	lb-ft	N-m	lb-ft
1/4	3.7	2.8	4.7	3.5	6	4.5	7.5	5.5	9.5	7	12	9	13.5	10	17	12.5
5/16	7.7	5.5	10	7	12	9	15	11	20	15	25	18	28	21	35	26
3/8	14	10	17	13	22	16	27	20	35	26	44	33	50	36	63	46
7/16	22	16	28	20	35	26	44	32	55	41	70	52	80	58	100	75
1/2	33	25	42	31	53	39	67	50	85	63	110	80	120	90	150	115
9/16	48	36	60	45	75	56	95	70	125	90	155	115	175	130	225	160
5/8	67	50	85	62	105	78	135	100	170	125	215	160	215	160	300	225
3/4	120	87	150	110	190	140	240	175	300	225	375	280	425	310	550	400
7/8	190	140	240	175	190	140	240	175	490	360	625	450	700	500	875	650
1	290	210	360	270	290	210	360	270	725	540	925	675	1050	750	1300	975
1-1/8	470	300	510	375	470	300	510	375	900	675	1150	850	1450	1075	1850	1350
1-1/4	570	425	725	530	570	425	725	530	1300	950	1650	1200	2050	1500	2600	1950
1-3/8	750	550	950	700	750	550	950	700	1700	1250	2150	1550	2700	2000	3400	2550
1-1/2	1000	725	1250	925	990	725	1250	930	2250	1650	2850	2100	3600	2650	4550	3350

DO NOT use these values if a different torque value or tightening procedure is given for a specific application. Torque values listed are for general use only. Check tightness of fasteners periodically.

Shear bolts are designed to fail under predetermined loads. Always replace shear bolts with identical grade.

^a "Lubricated" means coated with a lubricant such as engine oil, or fasteners with phosphate and oil coatings. "Dry" means plain or zinc plated without any lubrication.

^b Grade 2 applies for hex cap screws (not hex bolts) up to 152 mm (6-in.) long. Grade 1 applies for hex cap screws over 152 mm (6-in.) long, and for all other types of bolts and screws of any length.

Fasteners should be replaced with the same or higher grade. If higher grade fasteners are used, these should only be tightened to the strength of the original.

Make sure fasteners threads are clean and that you properly start thread engagement. This will prevent them from failing when tightening.

Tighten plastic insert or crimped steel-type lock nuts to approximately 50 percent of the dry torque shown in the chart, applied to the nut, not to the bolt head. Tighten toothed or serrated-type lock nuts to the full torque value.

FUEL

N **CAUTION:** Handle fuel carefully. If engine is hot or running, do not fill the fuel tank. Stop engine and allow to cool several minutes before filling fuel tank. Do not smoke while you fill the fuel tank or service the fuel system. Fill fuel tank only to bottom of filler neck.



10
20
1
-UN-23AUG88
TS185

IMPORTANT: To avoid engine damage, **DO NOT** mix oil with gasoline.

Unleaded fuel is recommended because it burns cleaner and leaves less unburned deposits in engine combustion chamber. Regular leaded gasoline with an anti-knock index of 87 or higher may be used.

Use of gasohol is acceptable as long as the ethyl alcohol blend does not exceed 10 percent. Unleaded gasohol is preferred over leaded gasohol.

Fuel Tank Capacity 30 L (8 U.S. gal)

Fill fuel tank at end of each day's operation.

MX,1020HJ,1 -19-14APR92

STORING FUEL

If there is a very slow turnover of fuel in the fuel tank or supply tank, it may be necessary to add a fuel conditioner to prevent water condensation. Contact your John Deere dealer for proper service or maintenance recommendations.

DX,FUEL -19-04JUN90

10
20
2

GASOLINE ENGINE OIL

Use oil viscosity based on the expected air temperature range during the period between oil changes.

John Deere PLUS-4® engine oil is recommended.

Other oils may be used if they meet API Service Classification SG or SF.

Oils meeting Military Specification MIL-L-46167A may be used as arctic oils.

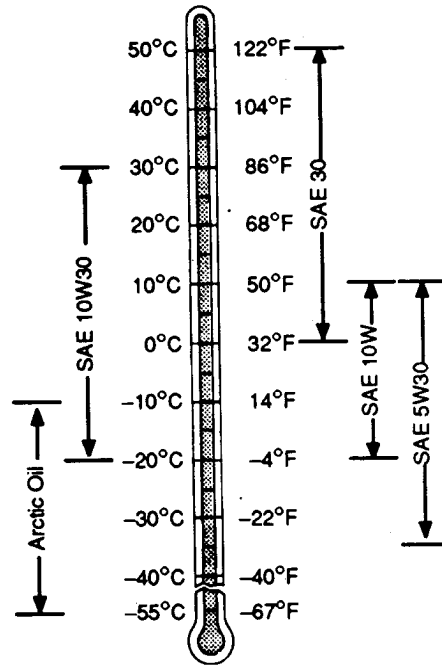

DX,GAS -19-15MAR91

TS239 -19-28NOV90

ENGINE COOLANT

John Deere Low Silicate Antifreeze is recommended.

Also recommended is low silicate antifreeze formulated to GM6038M or equivalent.

Other antifreezes that may be used:

- Ethylene-glycol type.
- Those containing not more than 0.1 percent anhydrous metasilicate.
- Those meeting General Motors Performance Specification GM1899M

IMPORTANT: Some types of ethylene-glycol antifreeze are intended for automotive use. These products are often labeled for use in aluminum engines and usually contain more than 0.1 percent of anhydrous metasilicate.

Check container label or consult with antifreeze supplier before using.

Mix 50-67 percent low silicate antifreeze with 33-50 percent distilled or deionized water.

Low silicate antifreeze provides:

- Adequate heat transfer.
- Corrosion-resistant environment within the cooling system.
- Compatibility with cooling system hose and seal material.
- Protection during cold and hot weather operations.

Certain geographical areas may require special antifreeze or coolant practices. If you have any questions, consult your authorized servicing dealer to obtain the latest information and recommendations.

DX,COOL -19-04JUN90

HYDROSTATIC DRIVE OIL

Use oil viscosity based on the expected air temperature range during the period between oil changes.

John Deere HY-GARD® Transmission/Hydraulic Oil is recommended.

Other oils may be used if they are QUATROL® oils or if they meet John Deere Standard JDM J20A or J20B.

Automatic transmission fluids of Type M2C33F or M2C33G may also be used.

Oils meeting Military Specification MIL-L-46167A may be used as arctic oils.

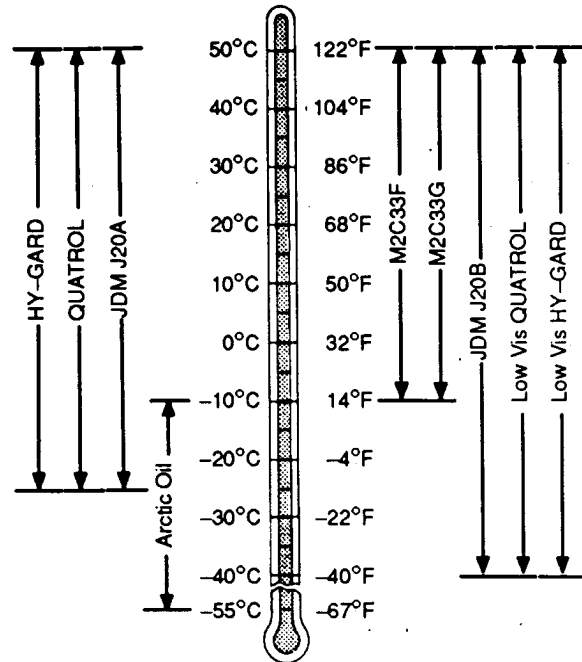

DX.HOIL2 -19-15MAR91

TS244 -19-28NOV90

EXTREME PRESSURE OR MULTIPURPOSE GREASE

Use grease based on the expected air temperature range during the service interval.

John Deere Moly High Temperature EP Grease and John Deere High Temperature EP Grease are recommended.

Other greases that may be used are:

- SAE Multipurpose EP Grease with 3 to 5 percent molybdenum disulfide.
- SAE Multipurpose EP Grease.
- Greases meeting Military Specification MIL-G-10924C may be used as arctic grease.

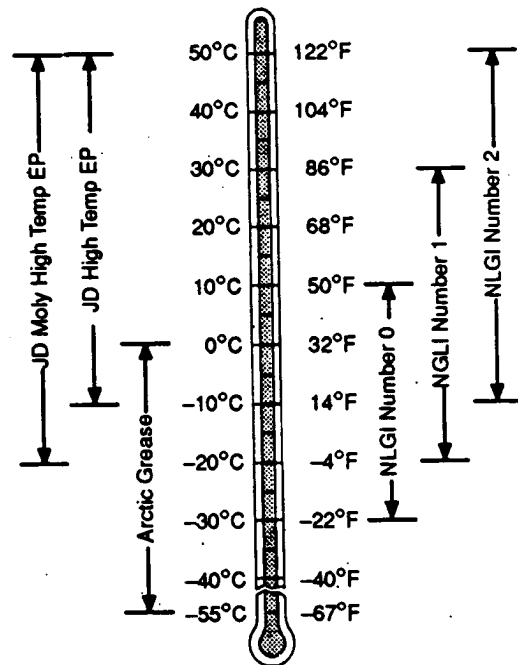

DX.GREA1 -19-15MAR91

TS248 -19-28NOV90

LUBRICANT STORAGE

Your equipment can operate at top efficiency only if clean lubricants are used.

Use clean containers to handle all lubricants.

Store lubricants and containers in an area protected from dust, moisture, and other contamination.

DX,LUBST -19-15MAR91

ALTERNATIVE LUBRICANTS

Conditions in certain geographical areas outside the United States and Canada may require different lubricant recommendations than these printed in the operator's manual. Consult manufacturer to obtain the alternative lubricant recommendations.

WX,622,FUEL,E -19-09MAY90