

Product: John Deere 16,18,20 and 24HP Onan Engines Service Repair Technical Manual
Full Download: <https://www.bobmanualstore.com/downloads/john-deere-161820-and-24hp-onan-engines-service-repair-technical-manual/>

16, 18, 20 and 24HP Onan Engines

Sample manual. Download All 224 pages at:

<https://www.bobmanualstore.com/downloads/john-deere-161820-and-24hp-onan-engines-service-repair-technical-manual/>

John Deere Horizon Works
CTM2 (19APR90)

LITHO IN U.S.A.
ENGLISH

Introduction

Product: John Deere 16,18,20 and 24HP Onan Engines Service Repair Technical Manual

Full Download: <https://www.bobmanualstore.com/downloads/john-deere-161820-a>

[nd-24hp-onan-engines-service-repair-technical-manual/](https://www.bobmanualstore.com/downloads/john-deere-161820-a)

This component technical manual (CTM) contains necessary instructions to repair the engine.

Use this component technical manual in conjunction with the machine technical manual. An engine application listing in the introduction identifies product-model/engine type-model relationship. See the machine technical manual for:

- Engine removal and installation.
- Theory of operation, diagnostic, and testing procedures.

N CAUTION: THIS SAFETY-ALERT SYMBOL MEANS ATTENTION! BECOME ALERT! YOUR SAFETY IS INVOLVED.

When you see this symbol on your machine or in your manual, be alert to the possibility of personal injury or death. Follow the instructions in the safety message.

Sample manual. Download All 224 pages at:

<https://www.bobmanualstore.com/downloads/john-deere-161820-and-24hp-onan-engines-service-repair-technical-man>

INTRODUCTION

This manual is part of a total service support program.

FOS MANUALS—REFERENCE

TECHNICAL MANUALS—MACHINE SERVICE

COMPONENT MANUALS—COMPONENT SERVICE

Fundamentals of Service (FOS) Manuals cover basic theory of operation, fundamentals of troubleshooting, general maintenance, and basic types of failures and their causes. FOS Manuals are for training new personnel and for reference by experienced technicians.

Technical Manuals are concise service guides for specific machines. Technical manuals are on-the-job guides containing only the vital information needed by an experienced service technician.

Component Technical Manuals are concise service guides for specific components. Component Technical Manuals are written as stand alone manuals covering multiple machine applications.

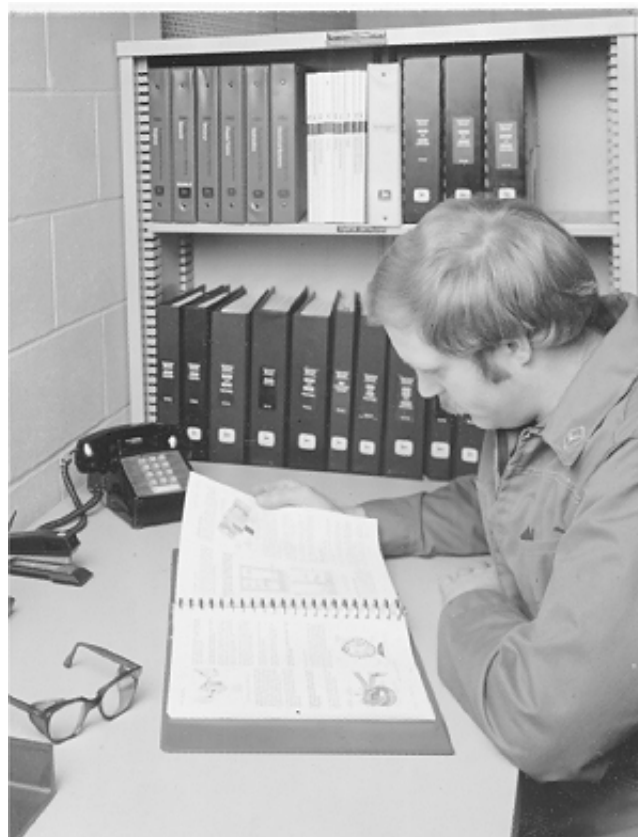

RW5559
-UN-23AUG88

O53.INTRO2 -19-03JUL85

FEATURES OF THIS TECHNICAL MANUAL

John Deere ILLUSTRATION format emphasizing illustrations and concise instructions in easy-to-use modules.

Emphasis on diagnosis, analysis, and testing so you can understand the problem and correct it.

Diagnostic information presented with the most logical and easiest to isolate problems first to help you identify the majority of routine failures quickly.

Step-by-step instructions for teardown and assembly.

Summary listing at the beginning of each group of all applicable specifications, wear tolerances, torque values, essential tools, and materials needed to do the job.

An emphasis throughout on safety—so you do the job right without getting hurt.

This technical manual was planned and written for you—an experienced service technician. Keep it in a permanent binder in the shop where it is handy. Refer to it when you need to know correct service procedures or specifications.



RW5560 -UN-23AUG88

O53,INTRO3 -19-07OCT85

ABOUT THIS MANUAL

This Component Technical Manual (CTM-2) covers the recommended repair procedures for all 16, 18, 20, and 24 HP Onan Engines removed from the machine. These engines can be repaired on a clean work bench or put on an engine stand.

Some components may be serviced without removing the engine from the machine. You may want to determine the repair procedure before you remove the engine. Refer to the machine technical manual for engine removal and installation procedures.

M98,INTR,1 -19-11NOV85

ENGINE SERIAL NUMBER PLATE

The engine serial number plate is located under the air cleaner.

Refer to the engine model designation on your engine's serial number plate to identify repair information covered in the Component Technical Manual.



M98,INTR,2 -19-07OCT85

BASIC ENGINE SPECIFICATIONS

ENGINE	B43E	B43G	P218G	B48G and P220G	T260
CYLINDER	2	2	2	2	2
CYCLE	4	4	4	4	4
BORE	82.55 mm (3.25 in.)	82.55 mm (3.25 in.)	82.55 mm (3.25 in.)	82.55 mm (3.25 in.)	90.42 mm (3.56 in.)
STROKE	66.55 mm (2.62 in.)	66.55 mm (2.62 in.)	73 mm 2.875 in.)	73 mm (2.87 in.)	76.20 mm (3.00 in.)
DISPLACEMENT	710 cm ³ (43.3 cu in.)	710 cm ³ (43 cu in.)	782 cm ³ 47.7 cu in.)	782 cm ³ (48 cu in.)	983 cm ³ (60 cu in.)
*HORSEPOWER	12kW (16 hp)	13.5 kW (18 HP)	13.4 kW (18 hp)	15 kW (20 hp)	18 kW (24 hp)

**Horsepower rating is established by engine manufacturer in accordance with Standard International Combustion Institute procedure. It is corrected to (60 °F) and 29.92 hg barometer. Laboratory test engines are equipped with air cleaner and muffler.*

M98,INTR,3 -19-10FEB87

ENGINE APPLICATION CHART

Refer to the engine application chart to identify product-model/engine type-model relationship.

CONSUMER PRODUCTS

Lawn and Garden Tractors

Machine No.	Engine Model
316	B43E or P218G
318	B43G or P218G
420	B48G or P220G

Front Mowers

Machine No.	Engine Model
F910	B48G or P220G
F930	T260

M98,INTR,4 -19-29JAN87

ENGLISH TORQUE SPECIFICATIONS

NOTE: Wrench torque tolerance is $\pm 20\%$.

Bolt Diameter	Plain Head*		Three Radial Dashes*		Six Radial Dashes*	
	lb-ft	N-m	lb-ft	N-m	lb-ft	N-m
1/4 in.	6	8	9	12	12	16
5/16 in.	10	14	18	24	25	34
3/8 in.	20	27	30	41	45	61
7/16 in.	30	41	50	68	70	95
1/2 in.	45	61	75	101	110	149
9/16 in.	70	95	110	150	155	210
5/8 in.	95	128	155	210	215	290
3/4 in.	165	225	270	365	385	520
7/8 in.	170	230	435	590	620	840
1 in.	255	345	660	895	930	1260

Torque figures indicated above and in the Specification Sections of this manual are valid for non-greased or non-oiled threads and heads unless otherwise specified. Therefore, do not grease or oil bolts or cap screws unless otherwise specified in this manual.

* Torque value for bolts and cap screws are identified by their head markings.

S11,2000,DD -19-11JUL85

METRIC TORQUE SPECIFICATIONS

NOTE: Wrench torque tolerance is $\pm 20\%$.

Bolt Diameter	Property Class 8.8*		Property Class 10.9*	
	lb-ft	N-m	lb-ft	N-m
M5	5	6	7	9
M6	8	10	11	15
M8	18	25	26	35
M10	37	50	52	70
M12	66	90	92	125
M16	166	225	229	310
M20	321	435	450	610
M24	554	750	775	1050

Torque figure indicated above and in the Specification Sections of this manual are valid for non-greased or non-oiled threads and heads unless otherwise specified. Therefore, do not grease or oil bolts or cap screws unless otherwise specified in this manual.

* Torque value for bolts and cap screws are identified by their head markings.

S11,2000,DE -19-11JUL85

SPECIFICATIONS

Item	Measurement	Specification
Breather Valve Cover Bolt	Torque	2 ± 1 N·m (18 ± 9 lb-in.)

M98,2005K,1 -19-07OCT85

REMOVE AIR CLEANER

1. Remove wing nut and cover.



M98,2005K,2 -19-07OCT85

2. Remove lock nut and air cleaner element.



M98,2005K,3 -19-07OCT85

3. Remove precleaner. Wash precleaner as necessary.



M98,2005K,4 -19-07OCT85

4. Wash precleaner in warm, soapy water. Rinse in clean water. Squeeze precleaner to remove most of water. Let precleaner air dry.



M98,2005K,5 -19-07OCT85

M34579 -UN-07SEP88

5. Hold a lighted bulb inside air cleaner element. If you can see the light through element and the paper appears clean, the element is still usable. If the element is oily, dirty, bent, torn, crushed or obstructed in any way, install a new element.



M98,2005K,6 -19-07OCT85

M34582 -UN-07SEP88

IMPORTANT: Close choke and all openings to keep objects from falling into carburetor, flywheel housing, and air intake system.

6. Remove three cap screws and splash plate (A).
7. Remove two base cap screws (B).
8. Push breather hose (C) from air cleaner base.
9. Lift air cleaner base from carburetor.
10. Clean inside of base and cover.
11. Inspect air intake hose for cracks or deterioration; replace if necessary.

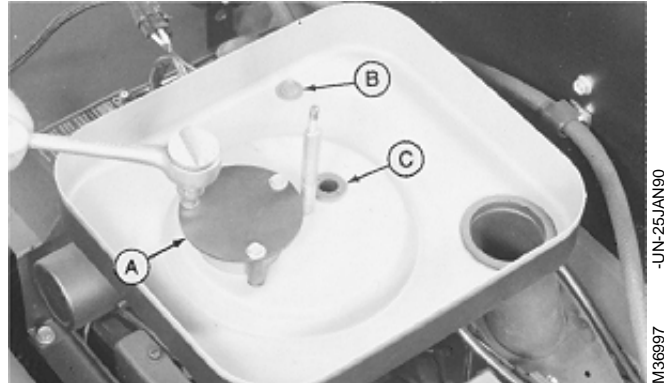

M98,2005K,7 -19-07OCT85

M36997 -UN-25-JAN90

INSTALL AIR CLEANER

1. Check carburetor intake to make sure the O-ring is in place.
2. Put air cleaner base on carburetor.
3. Install breather hose (C). Be sure breather hose and intake hose are tightly installed to prevent dirt from entering the system.
4. Install and tighten two cap screws (B).
5. Install and fasten splash plate (A) with three screws.

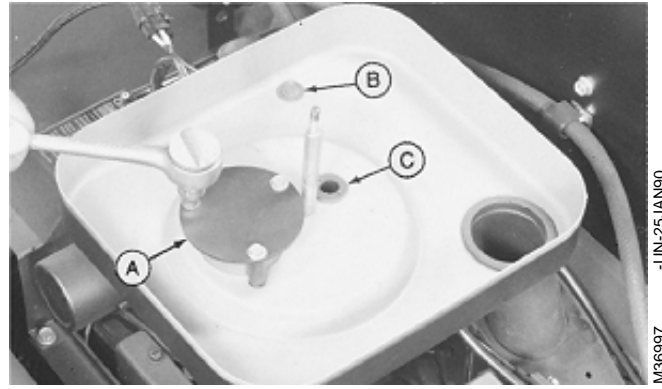

M98,2005K,8 -19-08OCT85

6. Apply 1 oz (30 ml) of clean engine oil to precleaner.
7. Squeeze precleaner to distribute oil evenly and to remove excess oil.

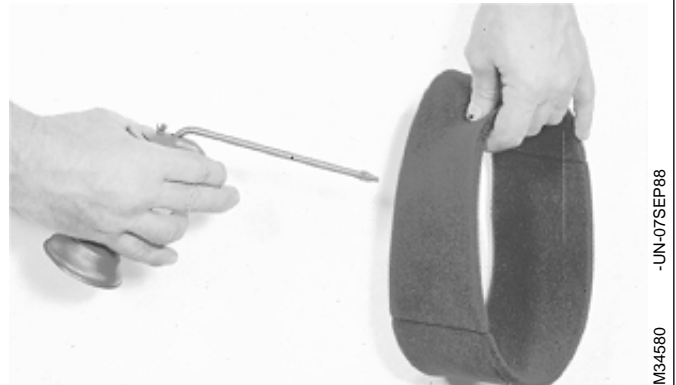

M34580 -UN-07SEP88
M98,2005K,9 -19-08OCT85

8. Put precleaner on air cleaner element. Install element and holddown.
9. Install lock nut. Tighten until snug only.



M366996 -UN-25JAN90
M98,2005K,10 -19-11NOV85

10. Install cover. Fasten with wing nut.



M98,2005K,11 -19-08OCT85

M36695
-UN-25JAN90

REPAIR BREATHER—T260 ENGINE

1. Remove air cleaner. (See Remove Air Cleaner in this section.)

2. Loosen clamp to remove breather tube.

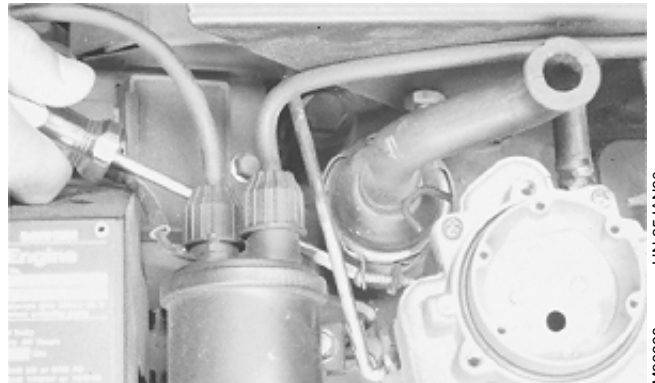

M98,2005K,12 -19-08OCT85

M36698
-UN-25JAN90

3. Remove filter packing.

4. Wash filter packing in a safe solvent and blow dry with air pressure. If packing comes apart or is deteriorated, replace it.

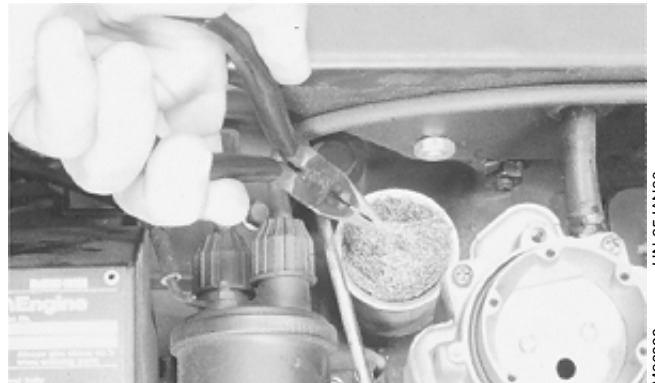

M98,2005K,13 -19-08OCT85

M36699
-UN-25JAN90

5. Wash breather valve with solvent.

Inspect ball valves to be sure they move freely.

Inspect O-ring for cuts or cracks. Replace if defective.

6. When installing breather tube, be sure filter packing is in breather and that the O-ring is installed on the valve assembly.



M98,2005K,14 -19-08OCT85

M37002
-UN-25JAN90

REPAIR BREATHER—B43E, B43G, B48G, P218G, AND P220G ENGINES

1. Remove air cleaner. (See Remove Air Cleaner in this group.)
2. Pull breather tube from breather assembly.

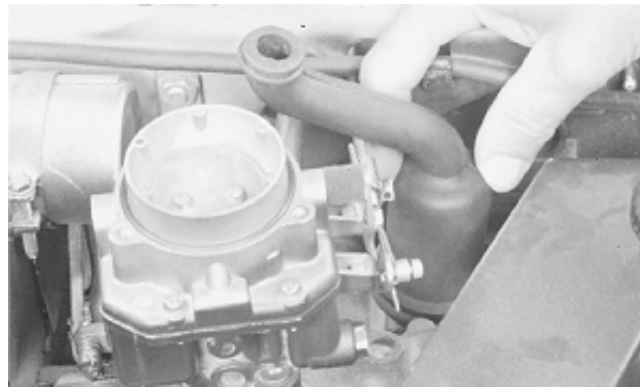

M98,2005K,15 -19-29JAN87

M37000
-UN-25JAN90
05

3. Remove filter packing.
4. Wash filter packing in a safe solvent and blow dry with air pressure. If packing comes apart or is deteriorated, replace it.



M98,2005K,16 -19-08OCT85

M37001
-UN-25JAN90

5. Remove three cap screws to remove manifold cover.

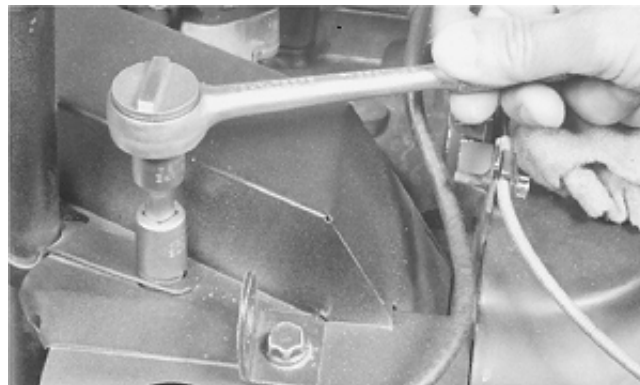

M98,2005K,17 -19-08OCT85

M37017
-UN-25JAN90

6. Remove cap screw (A).

IMPORTANT: Do not drop small parts into engine opening when removing breather assembly.

7. Remove breather assembly.

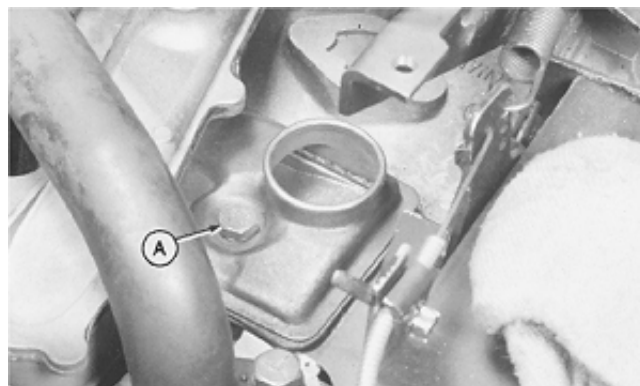

M98,2005K,18 -19-08OCT85

M37018
-UN-25JAN90

8. Clean parts with solvent. Inspect reed valve (C). Replace it if cracked or bent. Replace gaskets if broken or deteriorated.

NOTE: When installing the first gasket, be sure it aligns with the flange on the deflector (B). Apply a small amount of clean grease to the gaskets to hold them in place during installation.

9. Install in order:

- A—Gasket
- B—Deflector
- C—Reed Valve
- D—Washer
- E—Spring
- F—Gasket
- G—Valve Cover
- H—Washer
- I—Cap Screw

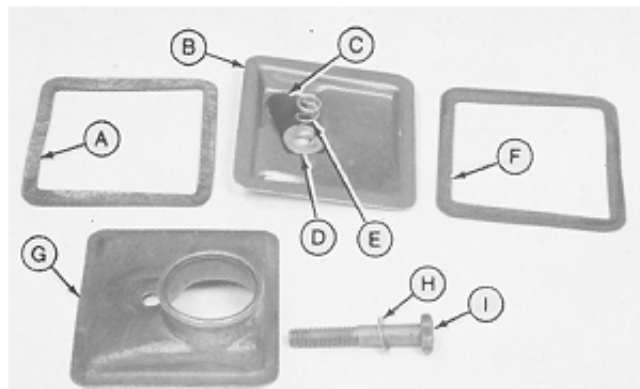

M98,2005K,19 -19-08OCT85

IMPORTANT: Be sure gaskets are in place before tightening cap screw. Breather will not function properly if air leaks are present.

10. Tighten cap screw to 2 ± 1 N·m (18 ± 9 lb-in.).

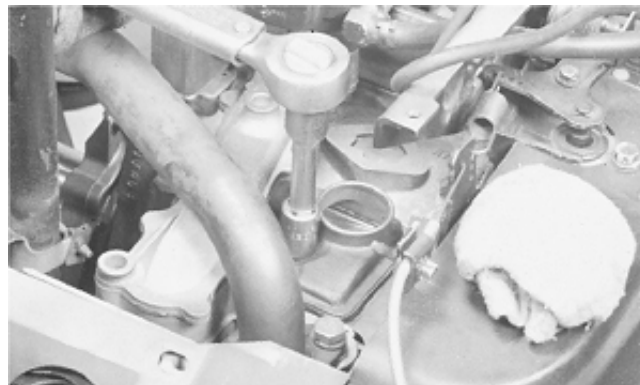

M98,2005K,20 -19-11NOV85

11. Install manifold cover. Fasten with three cap screws.

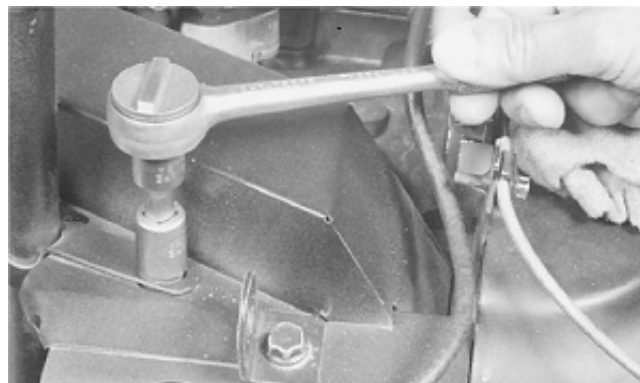

M98,2005K,21 -19-11NOV85

12. Install filter packing in breather tube.

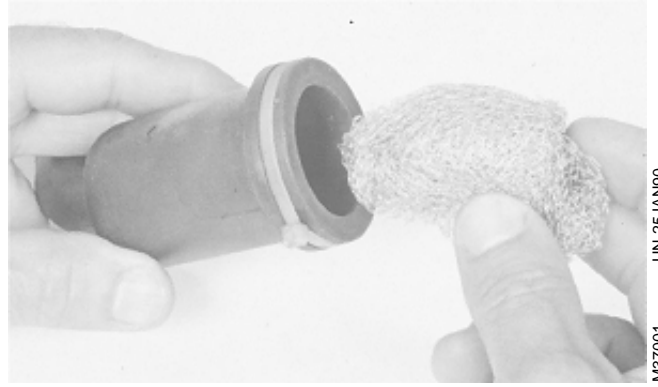

M98,2005K,22 -19-11NOV85

M37001
-UN-25JAN90
05
7

13. Push breather tube securely onto valve cover.

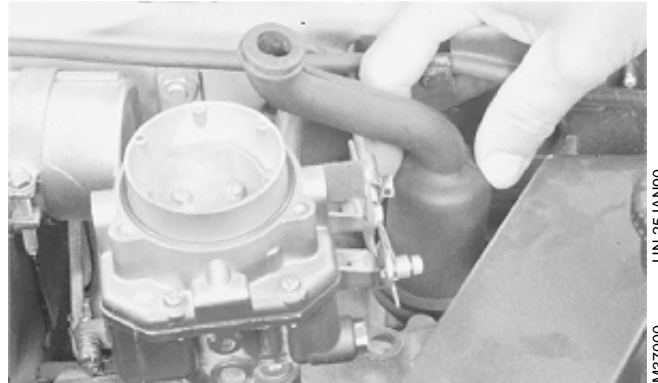

M98,2005K,23 -19-11NOV85

M37000
-UN-25JAN90

SERVICE EQUIPMENT AND TOOLS

NOTE: Order tools from the U.S. SERVICE-GARD™ Catalog or from the European Microfiche Tool Catalog (MTC). Some tools may be available from a local supplier.

Name	Use
Feeler Gauge	Measure cylinder head flatness

M98,2010K,1 -19-11NOV85

SERVICE PARTS KITS

The following kits are available through your parts catalog:

Overhaul Gasket Kit

M98,2010K,2 -19-08OCT85

SPECIFICATIONS

Item	Measurement	Specification
MUFFLER AND EXHAUST PIPES		
Exhaust Pipe Cap Screw		
P218G, P220G, B43E, B43G, B48G Engines	Torque	11 ± 3 N·m (97 ± 27 lb-in.)
T260 Engine	Torque	29 ± 2 N·m (257 ± 18 lb-in.)
Lift Bracket Cap Screw	Torque	11 ± 3 N·m (97 ± 27 lb-in.)
INTAKE MANIFOLD		
Attaching Cap Screw		
B43E, B43G, B48G Engines	Torque	11 ± 3 N·m (97 ± 27 lb-in.)
T260 Engine	Torque	29 ± 2 N·m (257 ± 18 lb-in.)
P218G, P220G Engines	Torque	6 N·m (53 lb-in.)
CYLINDER HEAD		
Cylinder Head	Flatness	0.005—0.10 mm (0.002—0.004 in.)
Attaching Cap Screws or Nuts		
P218G, P220G, B43E, B43G, B48G Engines	Torque-In Sequence	20 ± 1 N·m (180 ± 12 lb-in.)
T260 Engine:		
(Top six nuts with washers)	Torque-In Sequence	16 ± 1 N·m (142 ± 12 lb-in)
(Bottom four nuts)	Torque-In Sequence	20 ± 1 N·m (180 ± 12 lb-in.)
Lift Bracket Cap Screw	Torque	11 ± 3 N·m (97 ± 27 lb-in.)

M98,2010K,3 -19-10FEB87

REMOVE INTAKE MANIFOLD

1. Remove muffler. (See machine technical manual.)
2. Remove four cap screws to remove exhaust pipes and gasket (A). Inspect exhaust pipes for cracks or damage. Replace as necessary.
3. Remove air cleaner base. (See Group 05 in this manual.)

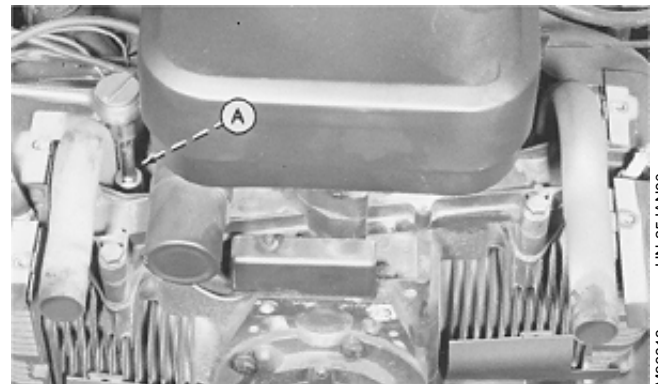

M36913 -UN-25JAN90

M98,2010K,4 -19-11NOV85

4. For T260 engines, remove two cap screws to remove coil bracket.

5. Remove clip (A) to disconnect throttle rod.

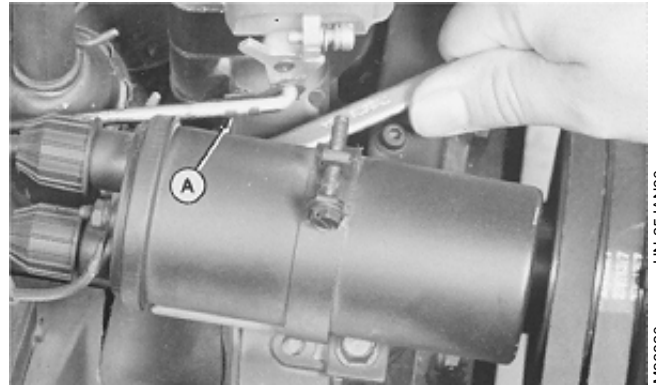

M98,2010K,5 -19-11NOV85

6. If engine is in machine, loosen clamp and screw (A) to disconnect choke cable (B).

7. If engine is in machine, slide hose clamp (C) back to disconnect fuel inlet line (D).

- A—Screw
- B—Choke Cable
- C—Hose Clamp
- D—Fuel Inlet Line

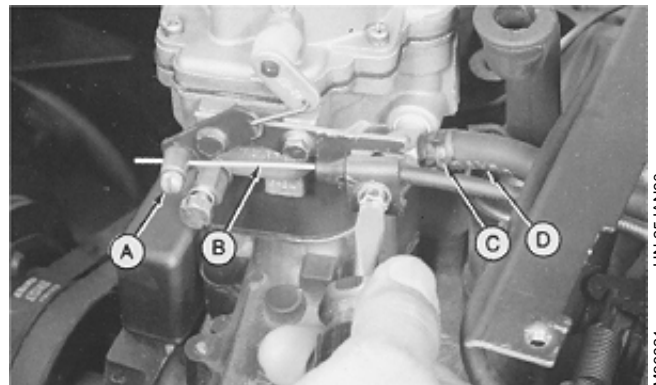

M98,2010K,6 -19-10FEB87

8. For T260 engine, remove four cap screws to remove intake manifold, carburetor, and gaskets (A).

For B43E, B43G, or B48G engine, remove three cap screws to remove spacer (B), intake manifold, carburetor, and gaskets (C).

For P218G and P220G engine, remove four cap screws to remove intake manifold, carburetor, and gaskets.



T260 Engine

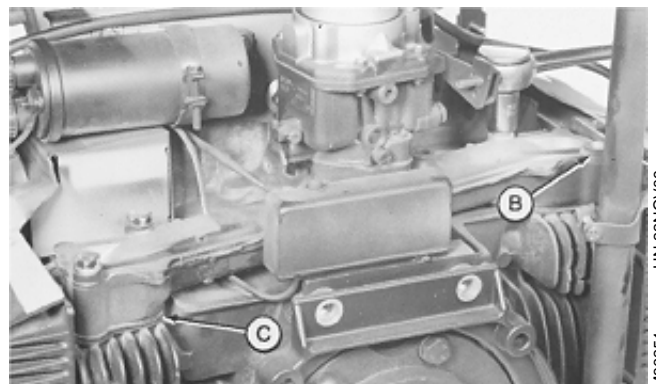

B43E, B43G, B48G Engines

M98,2010K,7 -19-10FEB87

9. For T260, P218G or P220G engine, remove two cap screws to remove carburetor, gasket (A), spacer (B), and gasket (C).

For B43E, B43G, or B48G engine, remove two cap screws to remove carburetor and gasket (A).

10. Inspect intake manifold for cracks or holes. Replace as necessary.

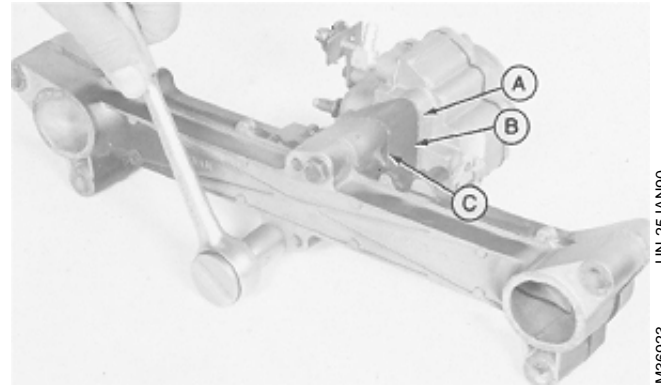

T260, P218G, P220G Engine

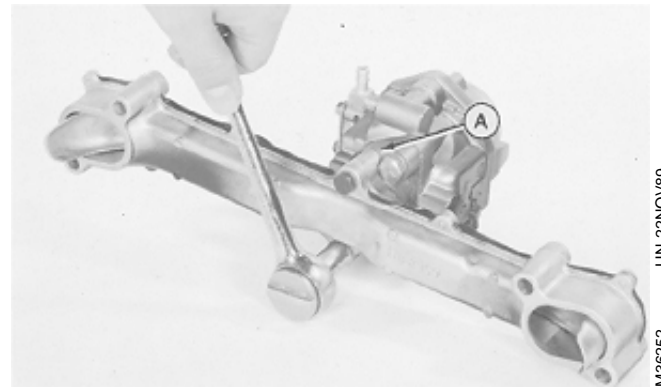

B43E, B43G, B48G Engines

M98,2010K,8 -19-10FEB87

INSTALL INTAKE MANIFOLD

1. Install a new gasket on intake manifold.



M98,2010K,9 -19-08OCT85

2. For T260, P218G, or P220G engine, install gasket (A) spacer (B), gasket (C), and carburetor on intake manifold. Install and tighten two cap screws.

For B43E, B43G, or B48G engine, install carburetor on intake manifold and fasten with cap screws.

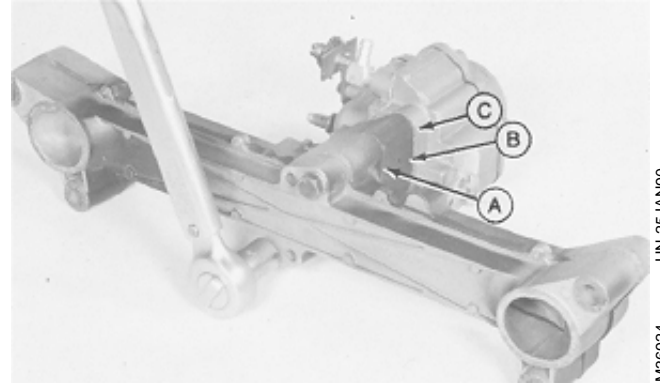

T260, P218G, P220G Engine

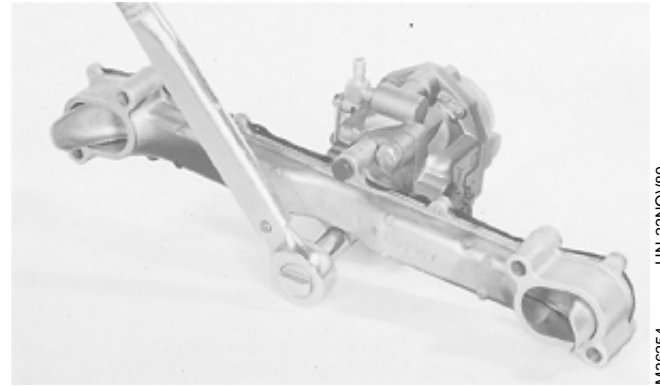

B43E, B43G, B48G Engines

M98.2010K,10 -19-30JAN87

NOTE: For T260 engine, go to step 5.

3. Install new gaskets with notch in gasket aligned with notch on intake port.

4. For B43E, B43G, or B48G engine, install intake manifold and tighten cap screws to 11 ± 3 N-m (97 ± 27 lb-in.). Install spacer (A).

For P218G or P220G engine, install intake manifold and oil fill tube. Tighten cap screws to 6 N-m (53 lb-in.).

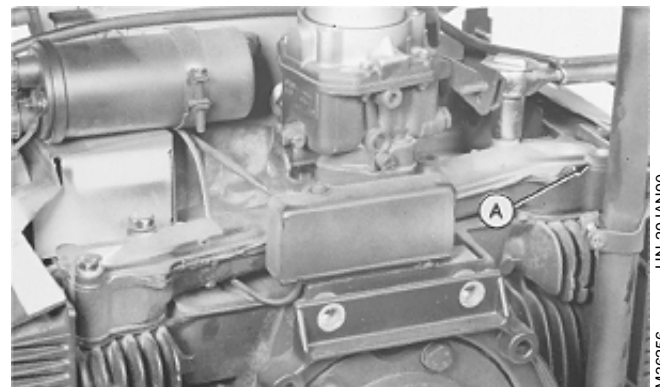

M98.2010K,11 -19-30JAN87

5. Install new gaskets on intake ports.

6. Install intake manifold and tighten cap screws to 29 ± 2 N-m (257 ± 18 lb-in.).

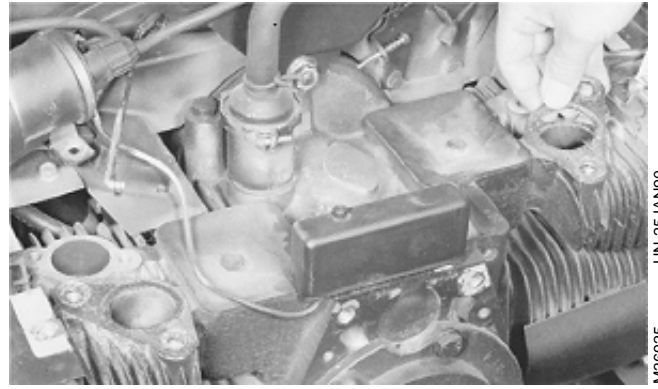

M36925 -UN-25JAN90

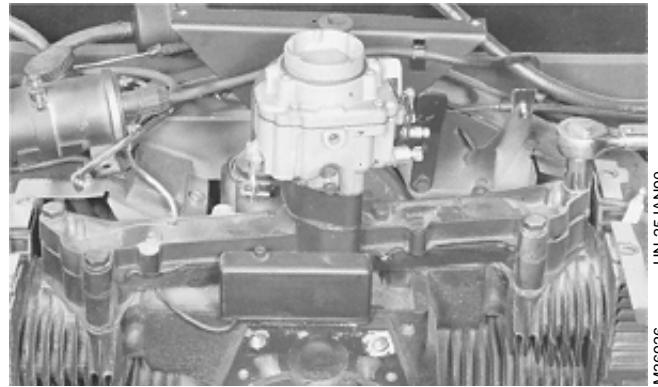

M36926 -UN-25JAN90

T260 engine

M98,2010K,12 -19-11NOV85

7. If engine is in machine, connect fuel inlet line (D) and fasten with hose clamp (C).

8. If engine is in machine, connect choke cable (B) to choke linkage. Push choke knob down. Hold choke linkage upward (choke plate open). Tighten screw (A) and clamp.

- A—Screw
- B—Choke Cable
- C—Hose Clamp
- D—Fuel Inlet Line

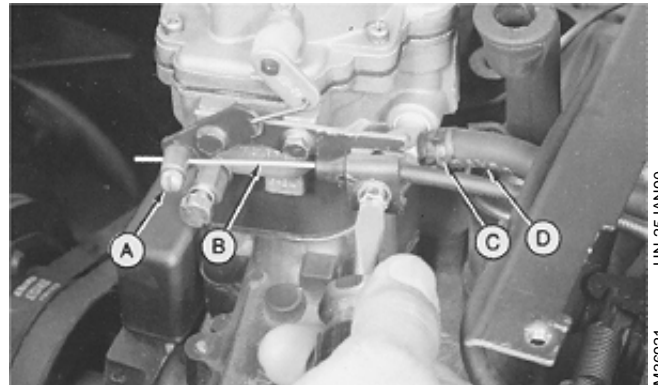

M36921 -UN-25JAN90

M98,2010K,13 -19-08OCT85

9. Connect throttle rod and fasten with clip (A).

10. For T260 engine, install coil bracket on intake manifold. Install and tighten two cap screws.

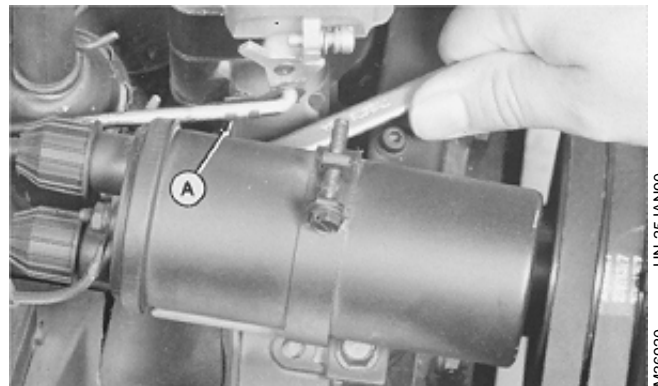

M36920 -UN-25JAN90

M98,2010K,14 -19-30JAN87

11. Install new exhaust pipe gaskets.
12. Install exhaust pipes and fasten with four cap screws.

EXHAUST PIPE TORQUE SPECIFICATIONS

Engine	Measurement	Specifications
T260	Cap Screw Torque	29 ± 2 N·m (257 ± 18 lb-in.)
B43E, B43G, B48G, P218G or P220G	Cap Screw Torque	11 ± 3 N·m (97 ± 27 lb-in.)

13. Install manifold covers and fasten with cap screws.
14. Install air cleaner assembly. (See Group 05 in this manual.)

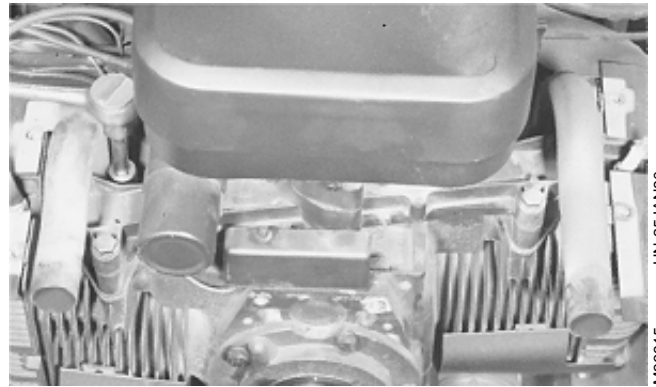
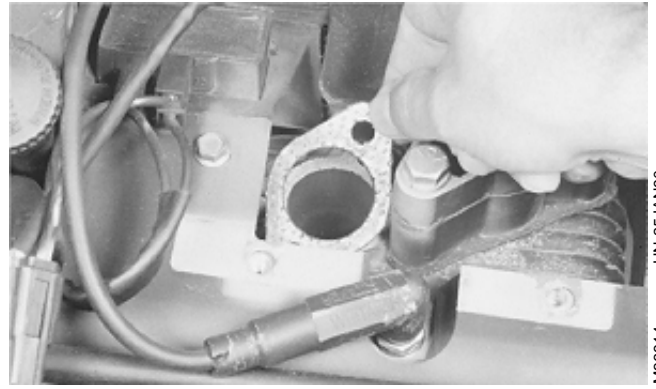

M36914 -UN-25JAN90

M36915 -UN-25JAN90

M98,2010K,15 -19-10FEB87

REMOVE CYLINDER HEAD

1. Park tractor safely.
2. Remove engine. (See machine technical manual.)
3. Disconnect spark plug wire (A).
4. For T260 engine, remove six cap screws to remove lift bracket (B), exhaust pipe shroud (C), and right side shroud (D).

For B43E, B43G, or B48G engine, remove four cap screws to remove lift bracket (B) and right side shroud (D).

For P218G or P220G engines, remove air cleaner assembly (See Group 05 in this manual.) Remove four cap screws to remove lift bracket and right side shroud.

- A—Spark Plug Wire
- B—Lift Bracket
- C—Exhaust Pipe Shroud
- D—Right Side Shroud

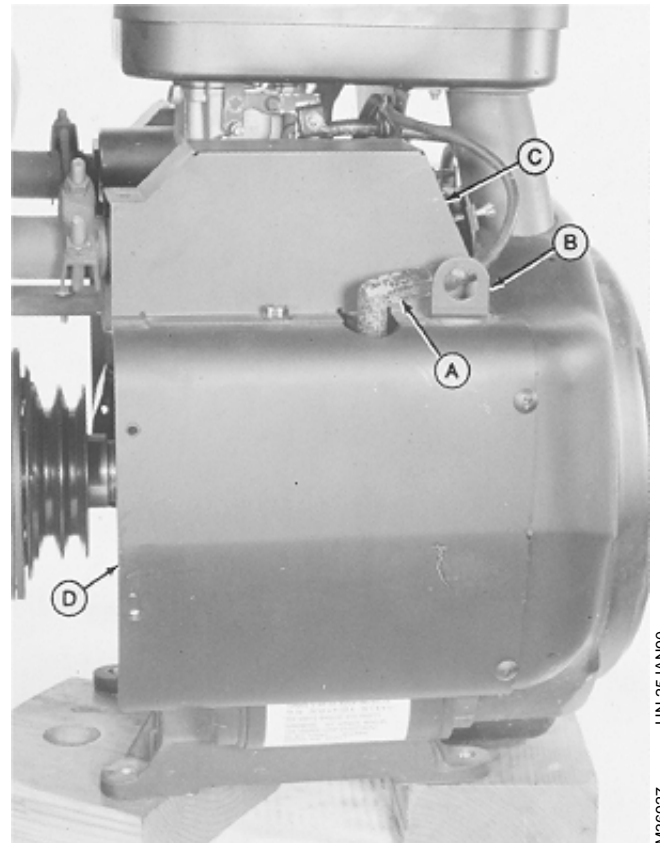

T260 Engine

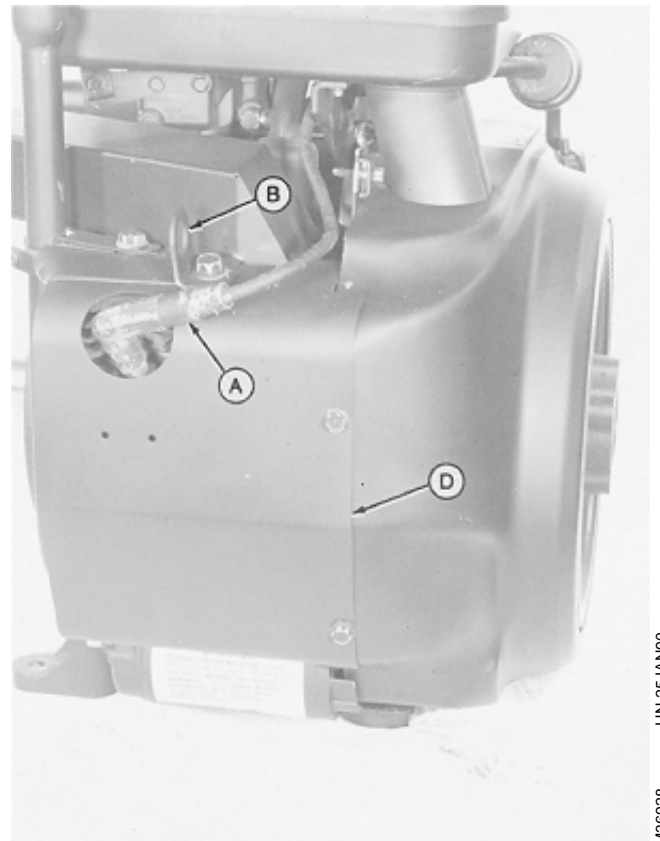

B43E, B43G, B48G Engines

M98.2010K,17 -19-30JAN87

5. Disconnect spark plug wire (A).

6. For T260 engine, remove seven cap screws to remove lift bracket (B), exhaust pipe shroud (C), and left side shroud (D).

For B43E, B43G, OR B48G engine, disconnect voltage regulator leads (E). Remove five cap screws to remove lift bracket (B) and left side shroud (D).

For P218G or P220G engines, disconnect voltage regulator leads. Remove four cap screws to remove lift bracket and left side shroud.

- A—Spark Plug Wire
- B—Lift Bracket
- C—Exhaust Pipe Shroud
- D—Left Side Shroud
- E—Voltage Regulator Leads

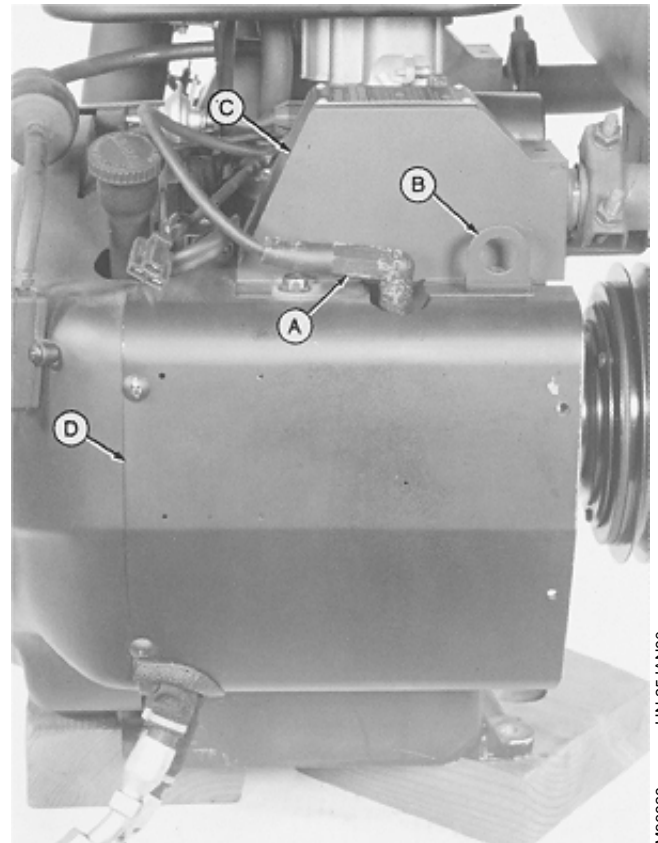

T260 Engine

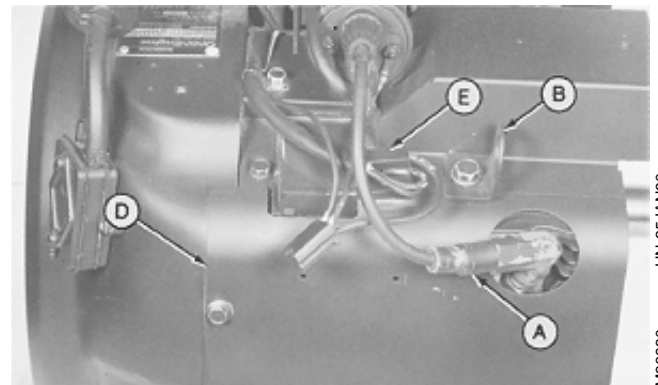

B43E, B43G, B48G Engines

M36929 -UN-25/JAN90
M36930 -UN-25/JAN90
M98,2010K,18 -19-10/FEB87

IMPORTANT: Do not remove cylinder heads while they are hot. Cylinder head may warp. A hot gasket will be soft and difficult to remove.

7. Remove spark plug (A).

8. For T260 engine, remove 10 nuts, 20 compression washers (B), and 10 washers (C) to remove cylinder head and gasket (D).

For P21G, P220G, B43E, B43G, OR B48G engine, remove nine cap screws and washers (E) to remove cylinder head and gasket (D).

- A—Spark Plug
- B—Compression Washer (20 Used)
- C—Washer (10 Used)
- D—Gasket
- E—Washer (9 Used)

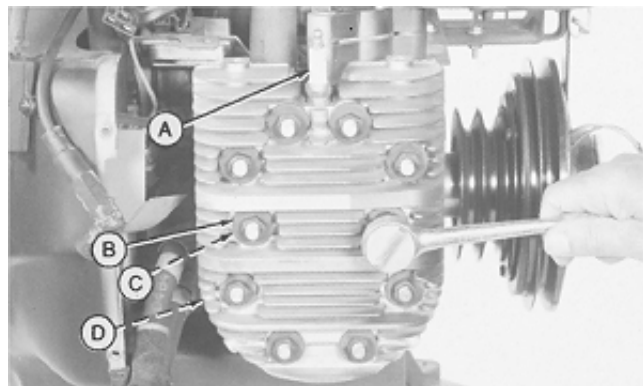

T260 Engine

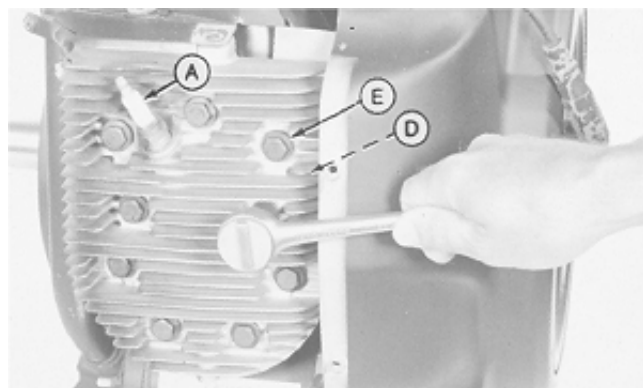

P218G, P220G, B43E, B43G, B48G

M98,2010K,19 -19-10FEB87

IMPORTANT: Do not damage gasket sealing surface while cleaning carbon deposits.

9. Carefully clean carbon deposits from combustion chamber and gasket surface on heads and cylinder block with a scraper and wire brush.

10. Inspect head for cracks or broken cooling fins. Check gasket sealing surface for burrs or nicks. Replace head if damaged.

11. Measure cylinder head flatness in several locations.



CYLINDER HEAD SPECIFICATIONS

Item	New Part	Wear Tolerance
Flat Within	0.05 mm (0.002 in.)	0.10 mm (0.004 in.)

Replace head if cylinder head is warped more than 0.10 mm (0.004 in.).

M98,2010K,20 -19-08OCT85

INSTALL CYLINDER HEAD

NOTE: To install cylinder head on P218G, P220G, B43E, B43G, OR B48G engine, go to step 4.

1. For T260 engine, install a new gasket (A) on cylinder head.

2. Install cylinder head on cylinder block. Install flat washer (B), two compression washers (C) with outside edges contacting each other, and nut (D) on each of the top six longer studs. Install flat washer and nut on each of the bottom four shorter studs. Tighten nuts in several steps in the sequence shown.

NUT TORQUE SPECIFICATIONS

Top six nuts 16 ± 1 N·m (142 ± 12 lb-in.)
(with compression washers)

Bottom four nuts 20 ± 1 N·m (180 ± 12 lb-in.)

3. Install spark plug (E).

- A—Gasket
- B—Washer (10 Used)
- C—Compression Washer (20 Used)
- D—Nut (10 Used)
- E—Spark Plug

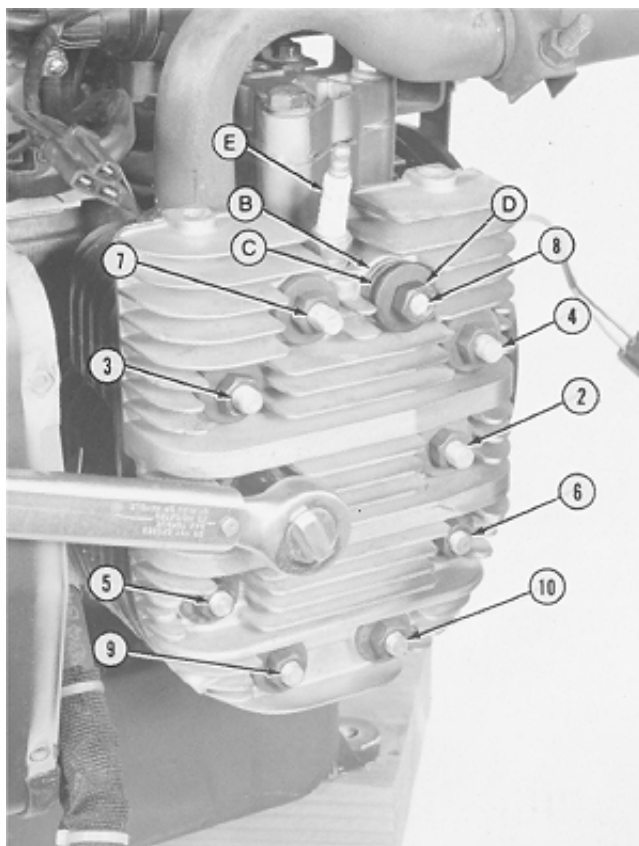
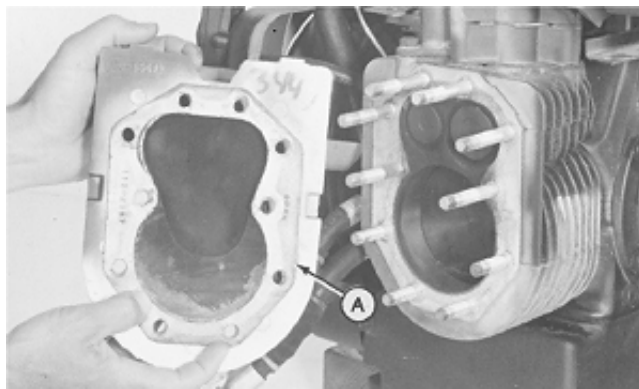

M36933 -UN-25JAN90

M36934 -UN-25JAN90

M98,2010K,21 -19-30JAN87

4. For P218G, P220G, B43E, B43G, or B48G engine, install a new gasket (A) on cylinder head.

5. Install cylinder head on cylinder block with the five longest cap screws in the top holes of cylinder head. Tighten cap screws in several steps in the sequence shown.

CAP SCREW TORQUE SPECIFICATION

Attaching Cap Screws 20 ± 1 N·m (180 ± 12 lb-in.)

6. Install spark plug (B).

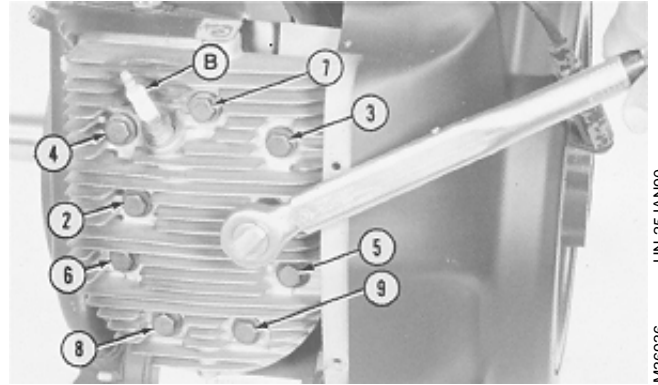
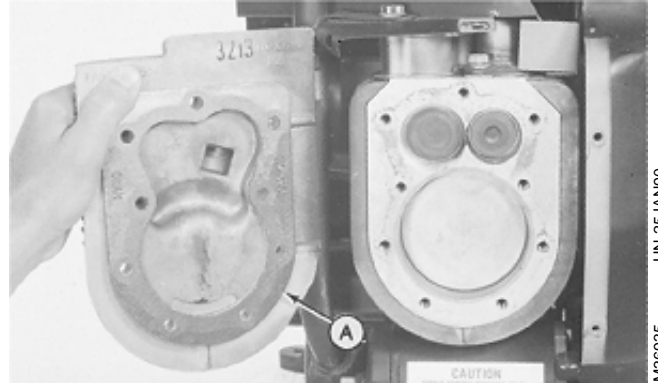

M36935 -UN-25JAN90

M36936 -UN-25JAN90

M98,2010K,22 -19-30JAN87

10
12

7. For T260 engine, install left side shroud (D), exhaust pipe shroud (C), lift bracket (B) and fasten with seven cap screws. Tighten lift bracket cap screw to 11 ± 3 N·m (97 ± 27 lb-in.).

For P218G or P220G engines, install left side shroud, lift bracket, and fasten with four cap screws. Tighten lift bracket cap screw to 11 ± 3 N·m (97 ± 27 lb-in.). Connect voltage regulator leads.

For B43E, B43G, OR B48G engine, install left side shroud (D), lift bracket (B), and fasten with five cap screws. Tighten lift bracket cap screw to 11 ± 3 N·m (97 ± 27 lb-in.).

Connect voltage regulator leads (E). Install the two stator leads on "AC" terminals and the battery lead on "B+" terminal of the voltage regulator.

8. Connect spark plug wire (A).

- A—Spark Plug Wire
- B—Lift Bracket
- C—Exhaust Pipe Shroud
- D—Left Side Shroud
- E—Voltage Regulator Leads

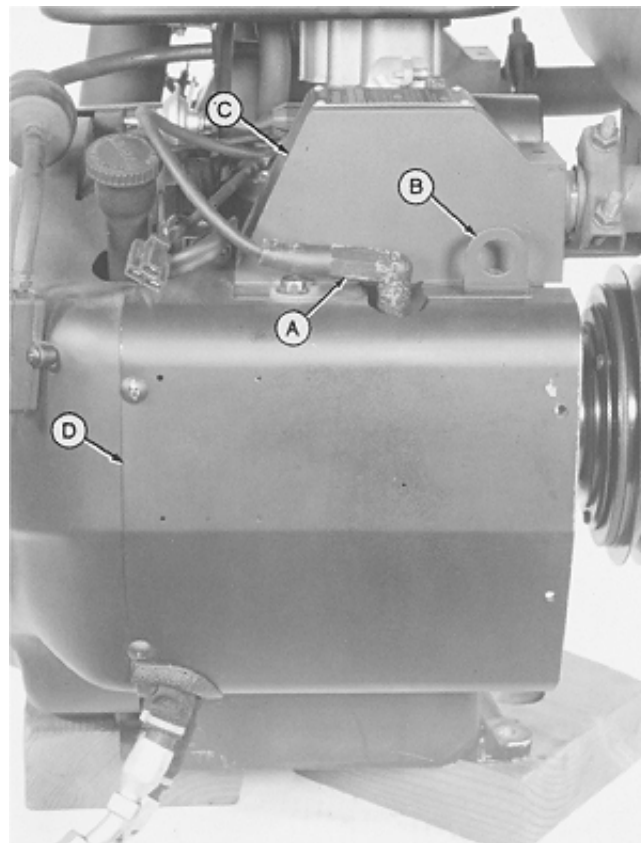

T260 Engine

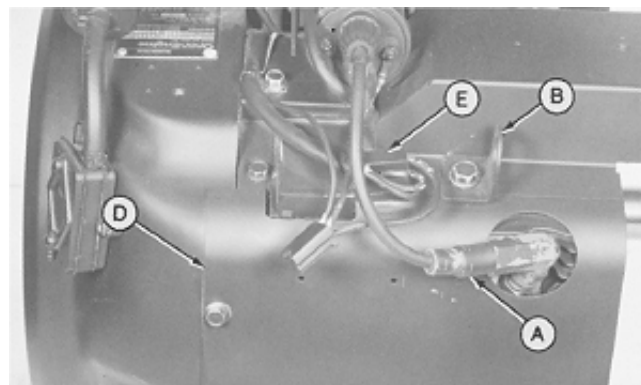

B43E, B43G, B48G Engines

M36929 -UN-25/JAN90
M36930 -UN-25/JAN90
M36930
M98,2010K,23 -19-10FEB87

9. For T260 engine, install right side shroud (D), exhaust pipe shroud (C), lift bracket (B), and fasten with six cap screws. Tighten lift bracket cap screw to 11 ± 3 N·m (97 ± 27 lb-in.).

For B43E, B43G, OR B48G engine, install right side shroud (D), lift bracket (B), and fasten with four cap screws. Tighten lift bracket cap screw to 11 ± 3 N·m (97 ± 27 lb-in.).

For P218G or P220G engines, install right side shroud, lift bracket, and fasten with four cap screws. Tighten lift bracket cap screw to 11 ± 3 N·m (97 ± 27 lb-in.).

10. Connect spark plug wire (A).

11. Install engine. (See machine technical manual.)

- A—Spark Plug Wire
- B—Lift Bracket
- C—Exhaust Pipe Shroud
- D—Right Side Shroud

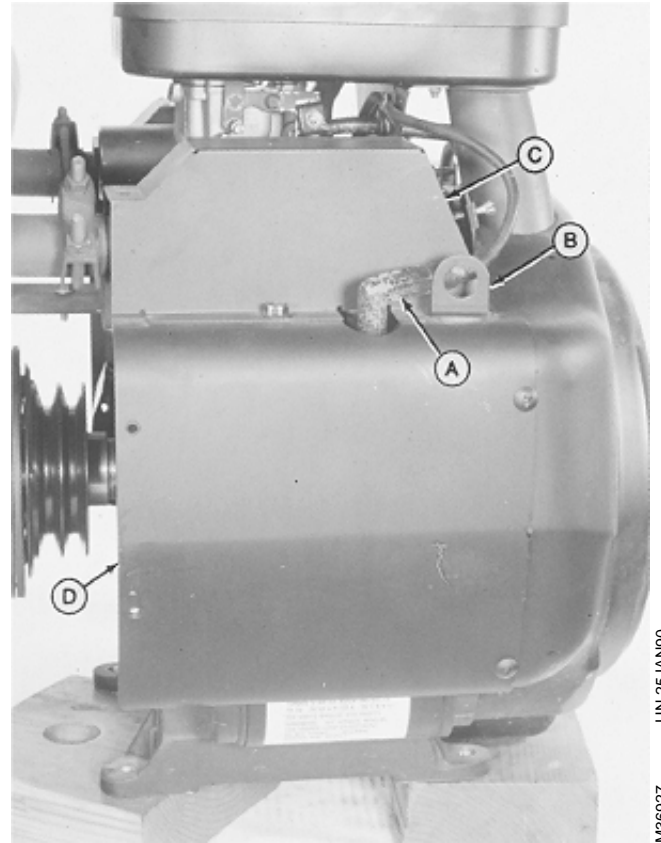

T260 Engine

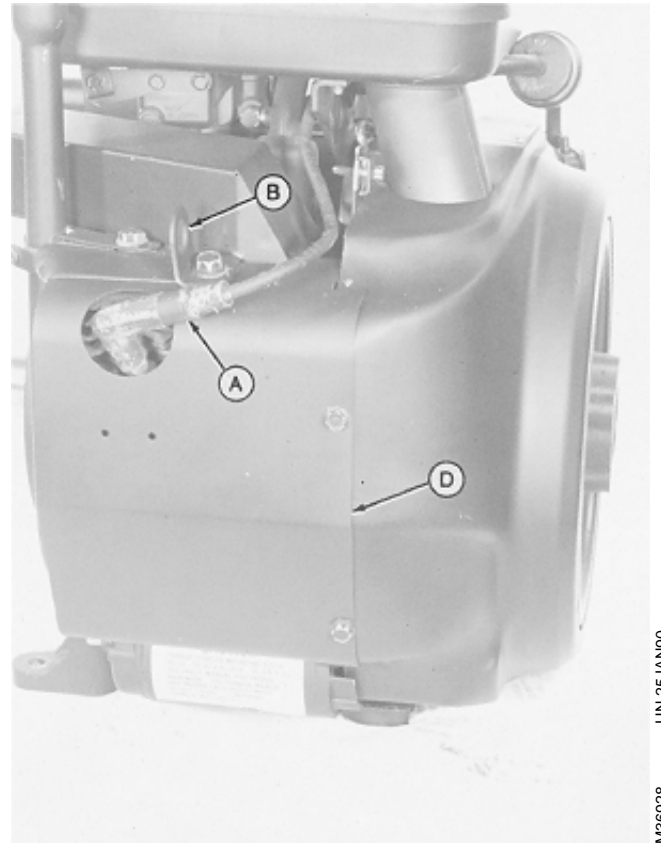

B43E, B43G, B48G Engines