

Product: John Deere 325 and 345 Lawn and Garden Tractors Service Repair Technical Manual

Full Download: [https://www.bobmanualstore.com/downloads/john-deere-325-and-](https://www.bobmanualstore.com/downloads/john-deere-325-and-345-lawn-and-garden-tractors-service-repair-technical-manual)

[345-lawn-and-garden-tractors-service-repair-technical-manual](https://www.bobmanualstore.com/downloads/john-deere-325-and-345-lawn-and-garden-tractors-service-repair-technical-manual)

/

JOHN DEERE
WORLDWIDE COMMERCIAL & CONSUMER
EQUIPMENT DIVISION

325 and 345
Lawn and Garden Tractors

TM1574 Feb-95

TECHNICAL MANUAL



JOHN DEERE

Litho in U.S.A.

Sample manual. Download All 470 pages at:

<https://www.bobmanualstore.com/downloads/john-deere-325-and-345-lawn-and-garden-tractors-service-repair-technical-manual>

/



This technical manual is written for an experienced technician and contains sections that are specifically for this product. It is a part of a total product support program.

The manual is organized so that all the information on a particular system is kept together. The order of grouping is as follows:

- Table of Contents
- Specifications
- Component Location
- System Schematic
- Theory of Operation
- Troubleshooting Chart
- Diagnostics
- Tests and Adjustments
- Repair

NOTE: Depending on the particular section or system being covered, not all of the above groups may be used.

Each section will be identified with a symbol rather than a number. The groups and pages within a section will be consecutively numbered.

All information, illustrations and specifications in this manual are based on the latest information available at the time of publication. The right is reserved to make changes at any time without notice.

We appreciate your input on this manual. To help, there are postage paid post cards included at the back. If you find any errors or want to comment on the layout of the manual please fill out one of the cards and mail it back to us.

Safety



Specifications and General Information



Engine—325 (FC540V)



Engine—345 (FD590V)



Electrical



Power Train (Hydrostatic)



Steering—325



Steering—345



Brakes



Hydraulics



Attachments



Miscellaneous



COPYRIGHT© 1995
JOHN DEERE HORICON WORKS
Horicon, Wisconsin
All rights reserved

RECOGNIZE SAFETY INFORMATION



T81389

This is the safety-alert symbol. When you see this symbol on your machine or in this manual, be alert to the potential for personal injury.

Follow recommended precautions and safe servicing practices.

Understand Signal Words

A signal word—DANGER, WARNING, or CAUTION—is used with the safety-alert symbol. DANGER identifies the most serious hazards.

DANGER or WARNING safety signs are located near specific hazards. General precautions are listed on CAUTION safety signs. CAUTION also calls attention to safety messages in this manual.

REPLACE SAFETY SIGNS

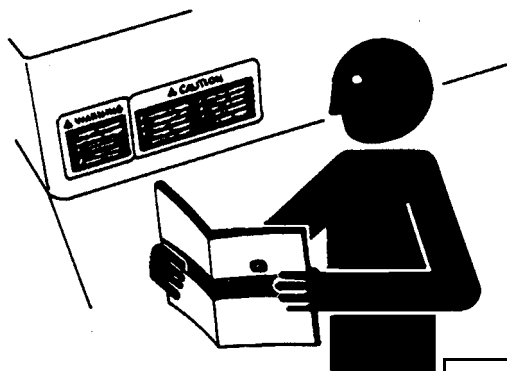

TS201

Replace missing or damaged safety signs. See the machine operator's manual for correct safety sign placement.

HANDLE FLUIDS SAFELY-AVOID FIRES



Be Prepared For Emergencies

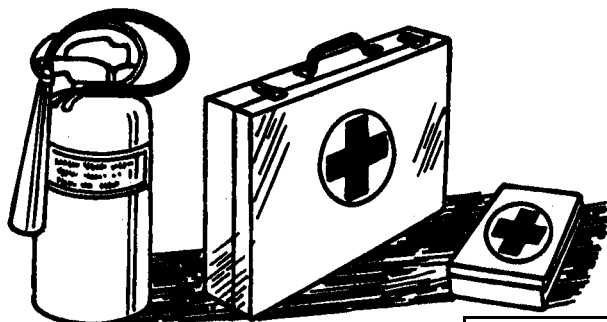

TS291



TS227

When you work around fuel, do not smoke or work near heaters or other fire hazards.

Store flammable fluids away from fire hazards. Do not incinerate or puncture pressurized containers.

Make sure machine is clean of trash, grease, and debris.

Do not store oily rags; they can ignite and burn spontaneously.

Be prepared if a fire starts.

Keep a first aid kit and fire extinguisher handy.

Keep emergency numbers for doctors, ambulance service, hospital, and fire department near your telephone.



USE CARE IN HANDLING AND SERVICING BATTERIES

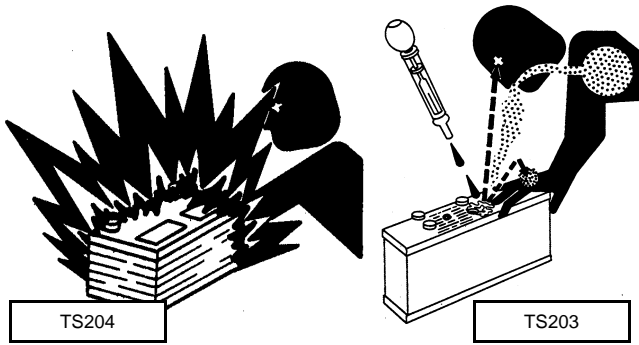

Prevent Battery Explosions

- Keep sparks, lighted matches, and open flame away from the top of battery. Battery gas can explode.
- Never check battery charge by placing a metal object across the posts. Use a volt-meter or hydrometer.
- Do not charge a frozen battery; it may explode. Warm battery to 16°C (60°F).

Prevent Acid Burns

- Sulfuric acid in battery electrolyte is poisonous. It is strong enough to burn skin, eat holes in clothing, and cause blindness if splashed into eyes.
- **Avoid acid burns by:**
 1. Filling batteries in a well-ventilated area.
 2. Wearing eye protection and rubber gloves.
 3. Avoiding breathing fumes when electrolyte is added.
 4. Avoiding spilling or dripping electrolyte.
 5. Use proper jump start procedure.
- **If you spill acid on yourself:**
 1. Flush your skin with water.
 2. Apply baking soda or lime to help neutralize the acid.
 3. Flush your eyes with water for 15-30 minutes.
 4. Get medical attention immediately.
- **If acid is swallowed:**
 1. Do not induce vomiting.
 2. Drink large amounts of water or milk, but do not exceed 1.9 L (2 quarts).
 3. Get medical attention immediately.

SERVICE COOLING SYSTEM SAFELY

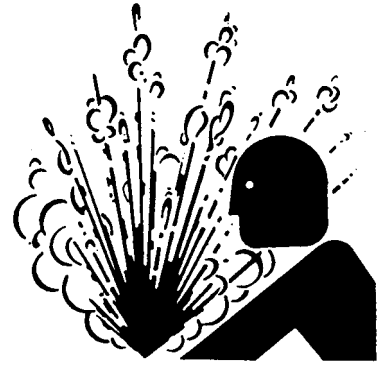

Explosive release of fluids from pressurized cooling system can cause serious burns.

Shut off machine. Only remove filler cap when cool enough to touch with bare hands. Slowly loosen cap to first stop to relieve pressure before removing completely.

USE SAFE SERVICE PROCEDURES

Wear Protective Clothing

Wear close fitting clothing and safety equipment appropriate to the job.

Prolonged exposure to loud noise can cause impairment or loss of hearing. Wear a suitable hearing protective device such as earmuffs or earplugs to protect against objectionable or uncomfortable loud noises.

Operating equipment safely requires the full attention of the operator. Do not wear radio or music headphones while operating machine.

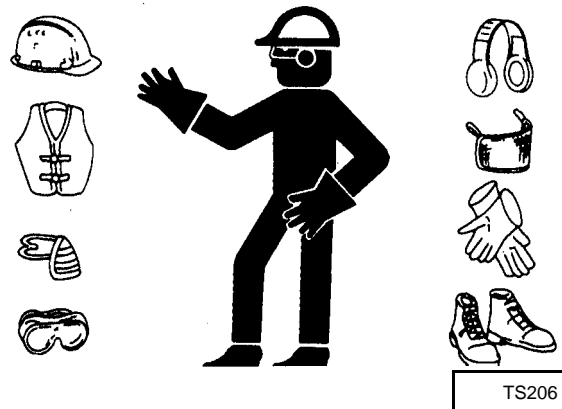

Service Machine Safely

Tie long hair behind your head. Do not wear a necktie, scarf, loose clothing, or necklace when you work near machine tools or moving parts. If these items were to get caught, severe injury could result.

Remove rings and other jewelry to prevent electrical shorts and entanglement in moving parts.

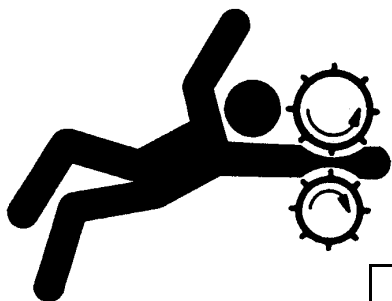

TS228

Use Proper Tools

Use tools appropriate to the work. Makeshift tools can create safety hazards. Use power tools only to loosen threaded parts and fasteners. For loosening and tightening hardware, use the correct size tools. **DO NOT** use U.S. measurement tools on metric fasteners. Use only service parts meeting John Deere specifications.

Park Machine Safely

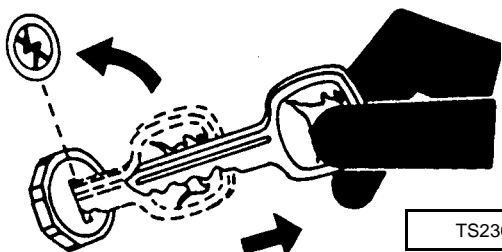

TS230

- **Before working on the machine:**

1. Lower all equipment to the ground.
2. Stop the machine and remove the key.
3. Disconnect the battery ground strap.
4. Hang a "DO NOT OPERATE" tag in operator station.

Support Machine Properly and Use Proper Lifting Equipment

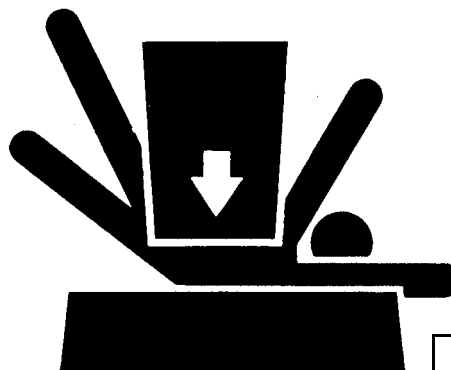

TS229

If you must work on a lifted machine or attachment, securely support the machine or attachment.

Do not support the machine on cinder blocks, hollow tiles, or props that may crumble under continuous load. Do not work under a machine that is supported solely by a jack. Follow recommended procedures in this manual.

Lifting heavy components incorrectly can cause severe injury or machine damage. Follow recommended procedure for removal and installation of components in the manual.

Work In A Clean Area

- **Before starting a job:**

1. Clean work area and machine.
2. Make sure you have all necessary tools to do your job.
3. Have the right parts on hand.
4. Read all instructions thoroughly; do not attempt shortcuts.

Illuminate Work Area Safely

Illuminate your work area adequately but safely. Use a portable safety light for working inside or under the machine. Make sure the bulb is enclosed by a wire cage. The hot filament of an accidentally broken bulb can ignite spilled fuel or oil.



Work In A Ventilated Area

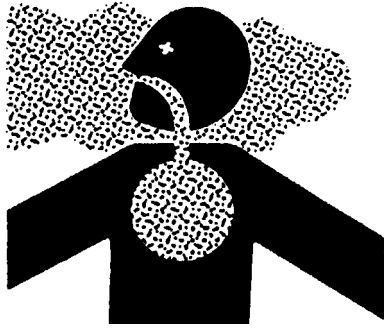

TS220

Engine exhaust fumes can cause sickness or death. If it is necessary to run an engine in an enclosed area, remove the exhaust fumes from the area with an exhaust pipe extension.

If you do not have an exhaust pipe extension, open the doors and get outside air into the area.

Remove Paint Before Welding Or Heating

Avoid potentially toxic fumes and dust. Hazardous fumes can be generated when paint is heated by welding, soldering, or using a torch. Do all work outside or in a well ventilated area. Dispose of paint and solvent properly. Remove paint before welding or heating: If you sand or grind paint, avoid breathing the dust. Wear an approved respirator. If you use solvent or paint stripper, remove stripper with soap and water before welding. Remove solvent or paint stripper containers and other flammable material from area. Allow fumes to disperse at least 15 minutes before welding or heating.

SERVICE TIRES SAFELY



TS952

Explosive separation of a tire and rim parts can cause serious injury or death.

Do not attempt to mount tire unless you have the proper equipment and experience to perform the job.

Always maintain the correct tire pressure. Do not inflate the tires above the recommended pressure. Never weld or heat a wheel and tire assembly. The heat can cause an increase in tire pressure resulting in a tire explosion. Welding can structurally weaken or deform the wheel.

When inflating tires, use a clip-on chuck and extension hose long enough to allow you stand to one side and NOT in front of or over the tire assembly. Use a safety cage if available.

Check wheels for low pressure, cuts, bubbles, damaged rims or missing lug bolts and nuts.

AVOID INJURY FROM ROTATING BLADES

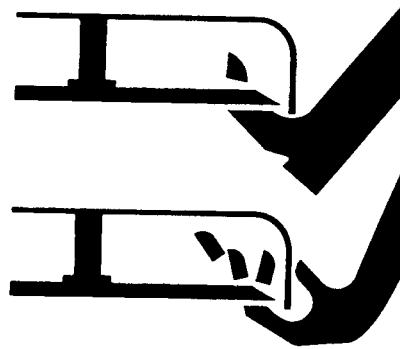

TS273

Keep hands and feet away while machine is running. Shut off power to service, lubricate or unlatch mower decks.

USE CARE AROUND HIGH-PRESSURE FLUID LINES

Avoid High-Pressure Fluids

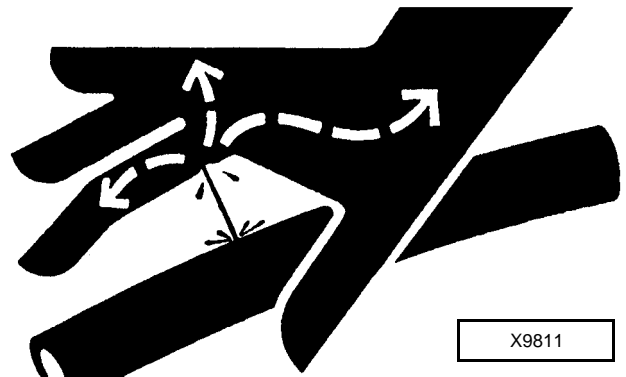

X9811

Escaping fluid under pressure can penetrate the skin causing serious injury.

Avoid the hazard by relieving pressure before disconnecting hydraulic or other lines. Tighten all connections before applying pressure.

Search for leaks with a piece of cardboard. Protect hands and body from high pressure fluids.

If an accident occurs, see a doctor immediately. Any fluid injected into the skin must be surgically removed within a few hours or gangrene may result. Doctors unfamiliar with this type of injury should reference a knowledgeable medical source. Such information is available from Deere & Company Medical Department in Moline, Illinois, U.S.A.

HANDLE CHEMICAL PRODUCTS SAFELY

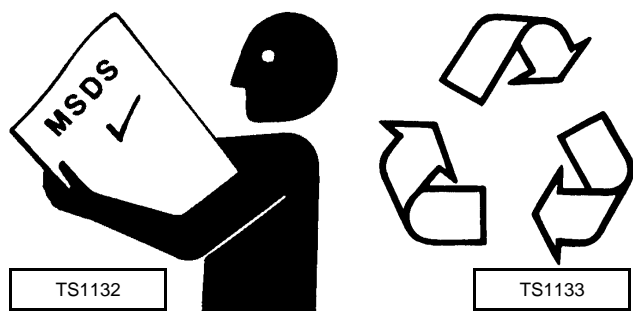

TS1132

TS1133

Direct exposure to hazardous chemicals can cause serious injury. Potentially hazardous chemicals used with John Deere equipment include such items as lubricants, coolants, paints, and adhesives.

A Material Safety Data Sheet (MSDS) provides specific details on chemical products: physical and health hazards, safety procedures, and emergency response techniques. Check the MSDS before you start any job using a hazardous chemical. That way you will know exactly what the risks are and how to do the job safely. Then follow procedures and recommended equipment.

Dispose of Waste Properly

Improperly disposing of waste can threaten the environment and ecology. Potentially harmful waste used with John Deere equipment include such items as oil, fuel, coolant, brake fluid, filters, and batteries. Use leakproof containers when draining fluids. Do not use food or beverage containers that may mislead someone into drinking from them. Do not pour waste onto the ground, down a drain, or into any water source. Inquire on the proper way to recycle or dispose of waste from your local environmental or recycling center, or from your John Deere dealer.



LIVE WITH SAFETY



TS231

Before returning machine to customer, make sure machine is functioning properly, especially the safety systems. Install all guards and shields.



This page intentionally left blank.

CONTENTS

Page

GENERAL VEHICLE SPECIFICATIONS 1-2

REPAIR INFORMATION

METRIC BOLT AND CAP SCREW TORQUE VALUES 1-5

UNIFIED INCH BOLT AND CAP SCREW TORQUE VALUES 1-6

SERVICE RECOMMENDATIONS FOR O-RING
BOSS FITTINGS 1-7

SERVICE RECOMMENDATIONS FOR FLAT FACE
O-RING SEAL FITTINGS 1-8

FUEL AND LUBRICANTS

GASOLINE 1-9

FUEL STORAGE 1-9

ENGINE OIL 1-9

ENGINE COOLANT - 345 1-10

OILSCAN AND COOLSCAN 1-10

GREASE 1-10

ANTI-CHATTER TRANSMISSION OIL 1-11

ALTERNATIVE LUBRICANTS 1-11

SYNTHETIC LUBRICANTS 1-11

OIL FILTER 1-11

LUBRICANT STORAGE 1-11

SERIAL NUMBER LOCATIONS

MACHINE IDENTIFICATION NUMBER 1-12

ENGINE SERIAL NUMBERS 1-12

CARBURETOR SERIAL NUMBERS 1-12

HYDROSTATIC TRANSMISSION SERIAL NUMBER 1-12

MOWER DECK SERIAL NUMBERS 1-13



VEHICLE SPECIFICATIONS

ENGINE- 325



Make John Deere "K" Series, Air Cooled
 Type Gasoline
 Model FC540V-AS15
 Aspiration Natural
 Horsepower (SAEJ1940) 12.6 kW (17 HP)
 Cylinders 1
 Displacement 535 cm³ (32.6 cu. in.)
 Stroke/Cycle 4 Cycle
 Bore 89 mm (3.500 in.)
 Stroke 86 mm (3.360 in.)
 Compression Ratio 8.3:1
 Slow Idle 1550 ± 75 rpm
 Fast Idle 3350 ± 50 rpm
 Valves Overhead
 Lubrication Pressurized
 Oil Filter Full Flow Filter
 Cooling System Air Cooled
 Air Cleaner Dual Stage Paper Air Filter
 and Foam Precleaner
 Muffler Horizontal discharge below frame
 Engine Oil Capacity
 With Filter 1.8 L (3.8 U.S. pt)
 Without Filter 1.6 L (3.4 U.S. pt)

ENGINE- 345

Make John Deere "K" Series, Liquid Cooled
 Type Gasoline
 Model FC590V-AS04
 Aspiration Natural
 Horsepower (SAEJ1940) 13.4 kW (18 HP)
 Cylinders 2, V-twin
 Displacement 585 cm³ (35.7 cu. in.)
 Stroke/Cycle 4 Cycle
 Bore 74 mm (2.900 in.)
 Stroke 68 mm (2.700 in.)
 Compression Ratio 8.7:1
 Slow Idle 1550 ± 75 rpm
 Fast Idle 3400 ± 75 rpm
 Valves Overhead
 Lubrication Pressurized
 Oil Filter Full Flow Filter
 Cooling System Liquid Cooled
 Coolant Capacity 3.1 L (3.3 qt)
 Air Cleaner Dual Stage Paper Air Filter
 and Foam Precleaner
 Muffler Horizontal discharge below frame
 Engine Oil Capacity
 With Filter 1.9 L (4.0 U.S. pt)
 Without Filter 1.7 L (3.6 U.S. pt)

FUEL SYSTEM

Fuel Tank Location	Rear
Fuel Tank Capacity (Total)	13.2 L (3.50 U.S. gal)
Fuel (min. octane)	Unleaded gasoline, 87 octane
Fuel Pump	
Location	
325	On Left-hand Side of Engine
345	On Front of Engine
Type	
325	Diaphragm Vacuum Pulse
345	Mechanical
Fuel Delivery	Float-Type Side Draft Carburetor
Fuel Shut-Off	Fuel Shutoff Solenoid (325)
Fuel Filter	Replaceable, In-line
Fuel Gauge	Translucent Fuel Tank



ELECTRICAL

Ignition	Electronic
Type of Starter	Solenoid Shift
Charging System	Flywheel Alternator
Charging Capacity:	
325	15 amp Regulated
345	17 amp Regulated
Battery Type	BCI Group, 45
Battery Voltage	12V
Battery Reserve Capacity at 25 amp	76 minutes
Battery Cold Cranking amps at 0° F	470 amps
Headlights	Incandescent, Standard (Halogen Bulbs, Optional)
Indicator Lights	Engine Oil Pressure, Battery Charge, Coolant Temperature (345)
Gauges	Hourmeter
Ignition Interlock Switches	Neutral Start, Operator Presence

PTO DRIVE

Type	V-Belt
Clutch Type	Engine Mounted, Electric

POWER TRAIN

Drive Wheels	Rear
Traction Drive	Hydrostatic, Twin Touch Foot Control
Transmission	Hydrostatic, Piston Type
Transmission Drive	Belt
Transmission Filter	Replaceable Internal Cartridge
Fan Blade Size	9 in. Diameter
Transmission Lubricant Capacity	4.3 L (4.7 qt)
Axle Type/Wheel Hubs	Straight with Separate 5-Bolt Hubs
Cruise Control	Forward Travel, Lever on Dash
Travel Speeds at Full RPM	
Forward	0—11.2 km/h (0—7 mph)
Reverse	0—6.4 km/h (0—4 mph)

STEERING

Type:
 325 Manual, Sealed Gearbox
 345 Power, Hydraulic, Front Wheels
 Tilt Wheel 5 Position



BRAKES

Location Transmission
 Type Internal Wet Disk, Single Pedal
 Parking Brake Brake Pedal Lock Lever

HYDRAULICS

System Lift and Steering (345)
 Lift Control Valve
 Type Mechanical, Spool Valve
 Location Under Tunnel Cover
 Cutting Unit Lift Rear Cylinder
 Filter 10 Micron, Replaceable, In-Line

IMPLEMENT LIFT

Lift System Hydraulic with Depth Stop
 Lift Lever Location Right-hand Side of Dash
 Cutting Heights 12.7—143.3 mm (6.35 mm increments)
 0.500—4.500 in. (0.250 in. increments)

MOWER ATTACHMENTS

Cutting Unit Drive Belt

WEIGHTS AND DIMENSIONS

Net Weight (less attachments and fuel)
 325 291 kg (642 lbs)
 345 317 kg (699 lbs)
 Mower Deck Weight
 38-Inch Mower Deck 43 kg (95 lbs)
 44-Inch Mower Deck 49 kg (108 lbs)
 48-Inch Mower Deck 57 kg (125 lbs)
 54-Inch Mower Deck 64 kg (140 lbs)
 Wheel Base 1.28 m (47.900 in.)
 Tread Width 0.74 m (29 in.)
 Turning Radius (inside rear wheel) 0.64 m (25 in.)
 Overall Length 1.84 m (72.250 in.)
 Overall Height 1.11 m (43.6 in.)
 Overall Width (less attachments) 0.99—1.05 m (39—41.5 in.)
 With 38-Inch Mower Deck 1.33 m (52.600 in.)
 With 44-Inch Mower Deck 1.16 m (45.700 in.)
 With 48-Inch Mower Deck 1.52 m (60 in.)
 With 54-Inch Mower Deck 1.68 m (66 in.)











WHEELS AND TIRES

Front 16 x 6.50-8.00, 2 or 4 ply, Turf
 Rear 23 x 10.50-12.00, Turf or Bar

(Specifications and design subject to change without notice.)

METRIC BOLT AND CAP SCREW TORQUE VALUES



SAE Grade and Head Markings	1 or 2 ^b No Marks 	5  5.1  5.2 	8  8.2 
	2 No Marks 	5  	8  

TS1162

	Class 4.8		Class 8.8 or 9.8		Class 10.9		Class 12.9									
	Lubricated ^a		Dry ^a		Lubricated ^a		Dry ^a		Lubricated ^a		Dry ^a		Lubricated ^a		Dry ^a	
Size	Nm	lb-ft	Nm	lb-ft	Nm	lb-ft	Nm	lb-ft	Nm	lb-ft	Nm	lb-ft	Nm	lb-ft	Nm	lb-ft
M6	4.8	3.5	6	4.5	9	6.5	11	8.5	13	9.5	17	12	15	11.5	19	14.5
M8	12	8.5	15	11	22	16	28	20	32	24	40	30	37	28	47	35
M10	23	17	29	21	43	32	55	40	63	47	80	60	75	55	95	70
M12	40	29	50	37	75	55	95	70	110	80	140	105	130	95	165	120
M14	63	47	80	60	120	88	150	110	175	130	225	165	205	150	260	190
M16	100	73	125	92	190	140	240	175	275	200	350	255	320	240	400	300
M18	135	100	175	125	260	195	330	250	375	275	475	350	440	325	560	410
M20	190	140	240	180	375	275	475	350	530	400	675	500	625	460	800	580
M22	260	190	330	250	510	375	650	475	725	540	925	675	850	625	1075	800
M24	330	250	425	310	650	475	825	600	925	675	1150	850	1075	800	1350	1000
M27	490	360	625	450	950	700	1200	875	1350	1000	1700	1250	1600	1150	2000	1500
M30	675	490	850	625	1300	950	1650	1200	1850	1350	2300	1700	2150	1600	2700	2000
M33	900	675	1150	850	1750	1300	2200	1650	2500	1850	3150	2350	2900	2150	3700	2750
M36	1150	850	1450	1075	2250	1650	2850	2100	3200	2350	4050	3000	3750	2750	4750	3500

DO NOT use these values if a different torque value or tightening procedure is given for a specific application. Torque values listed are for general use only. Check tightness of fasteners periodically.

Shear bolts are designed to fail under predetermined loads. Always replace shear bolts with identical grade.

Fasteners should be replaced with the same or higher grade. If higher grade fasteners are used, these should only be tightened to the strength of the original. Make sure fasteners threads are clean and that you properly start thread engagement. This will prevent them from failing when tightening.

Tighten plastic insert or crimped steel-type lock nuts to approximately 50 percent of the dry torque shown in the chart, applied to the nut, not to the bolt head. Tighten toothed or serrated-type lock nuts to the full torque value.

^a "Lubricated" means coated with a lubricant such as engine oil, or fasteners with phosphate and oil coatings. "Dry" means plain or zinc plated without any lubrication.

UNIFIED INCH BOLT AND CAP SCREW TORQUE VALUES



Property Class and Head Markings	4.8	8.8	9.8	10.9	12.9
Property Class and Nut Markings	5	10	10	12	

TS1163

Size	Grade 1		Grade 2 ^b				Grade 5, 5.1 or 5.2				Grade 8 or 8.2					
	Lubricated ^a		Dry ^a		Lubricated ^a		Dry ^a		Lubricated ^a		Dry ^a		Lubricated ^a		Dry ^a	
	Nm	lb-ft	Nm	lb-ft	Nm	lb-ft	Nm	lb-ft	Nm	lb-ft	Nm	lb-ft	Nm	lb-ft	Nm	lb-ft
1/4	3.7	2.8	4.7	3.5	6	4.5	7.5	5.5	9.5	7	12	9	13.5	10	17	12.5
5/16	7.7	5.5	10	7	12	9	15	11	20	15	25	18	28	21	35	26
3/8	14	10	17	13	22	16	27	20	35	26	44	33	50	36	63	46
7/16	22	16	28	20	35	26	44	32	55	41	70	52	80	58	100	75
1/2	33	25	42	31	53	39	67	50	85	63	110	80	120	90	150	115
9/16	48	36	60	45	75	56	95	70	125	90	155	115	175	130	225	160
5/8	67	50	85	62	105	78	135	100	170	125	215	160	240	175	300	225
3/4	120	87	150	110	190	140	240	175	300	225	375	280	425	310	550	400
7/8	190	140	240	175	190	140	240	175	490	360	625	450	700	500	875	650
1	290	210	360	270	290	210	360	270	725	540	925	675	1050	750	1300	975
1-1/8	470	300	510	375	470	300	510	375	900	675	1150	850	1450	1075	1850	1350
1-1/4	570	425	725	530	570	425	725	530	1300	950	1650	1200	2050	1500	2600	1950
1-3/8	750	550	950	700	750	550	950	700	1700	1250	2150	1550	2700	2000	3400	2550
1-1/2	1000	725	1250	925	990	725	1250	930	2250	1650	2850	2100	3600	2650	4550	3350

DO NOT use these values if a different torque value or tightening procedure is given for a specific application. Torque values listed are for general use only. Check tightness of fasteners periodically.

Shear bolts are designed to fail under predetermined loads. Always replace shear bolts with identical grade.

Fasteners should be replaced with the same or higher grade. If higher grade fasteners are used, these should only be tightened to the strength of the original. Make sure fasteners threads are clean and that you properly start thread engagement. This will prevent them from failing when tightening.

Tighten plastic insert or crimped steel-type lock nuts to approximately 50 percent of the dry torque shown in the chart, applied to the nut, not to the bolt head. Tighten toothed or serrated-type lock nuts to the full torque value.

^a "Lubricated" means coated with a lubricant such as engine oil, or fasteners with phosphate and oil coatings. "Dry" means plain or zinc plated without any lubrication.

^b Grade 2 applies for hex cap screws (not hex bolts) up to 152 mm (6 in.) long. Grade 1 applies for hex cap screws over 152 mm (6 in.) long, and for all other types of bolts and screws of any length.

SERVICE RECOMENDATIONS FOR O-RING BOSS FITTINGS

Straight Fitting

1. Inspect O-ring boss seal for dirt or defects.
2. Lubricate O-rings with petroleum jelly. Place electrical tape over threads to protect O-ring. Slide O-ring over tape and into O-ring groove of fitting. Remove tape.
3. Tighten fitting to torque value shown on chart.

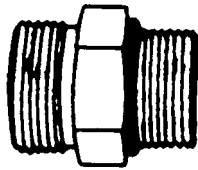

M82649A

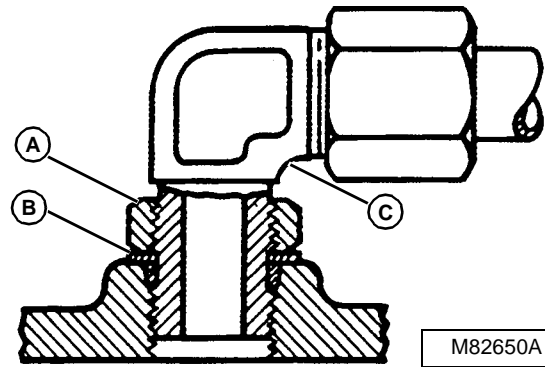

M82650A

NOTE: Do not allow hoses to twist when tightening fittings.

TORQUE VALUE

Thread Size	N•m	lb-ft
3/8-24 UNF	8	6
7/16-20 UNF	12	9
1/2-20 UNF	16	12
9/16-18 UNF	24	18
3/4-16 UNF	46	34
7/8-14UNF	62	46
1-1/16-12 UN	102	75
1-3/16-12 UN	122	90
1-5/16-12 UN	142	105
1-5/8-12 UN	190	140
1-7/8-12 UN	217	160

NOTE: Torque tolerance is ± 10%

Angle Fitting

1. Back-off lock nut (A) and back-up washer (B) completely to head-end (C) of fitting.
2. Turn fitting into threaded boss until back-up washer contacts face of boss.
3. Turn fitting head-end counterclockwise to proper index (maximum of one turn).
4. Hold fitting head-end with a wrench and tighten locknut and back-up washer to proper torque value.

SERVICE RECOMENDATIONS FOR FLAT FACE O-RING SEAL FITTINGS



1. Inspect the fitting sealing surfaces. They must be free of dirt or defects.
2. Inspect the O-ring. It must be free of damage or defects.
3. Lubricate O-rings and install into groove using petroleum jelly to hold in place.
4. Push O-ring into the groove with plenty of petroleum jelly so O-ring is not displaced during assembly.
5. Index angle fittings and tighten by hand pressing joint together to insure O-ring remains in place.

6. Tighten fitting or nut to torque value shown on the chart per dash size stamped on the fitting. Do not allow hoses to twist when tightening fittings.

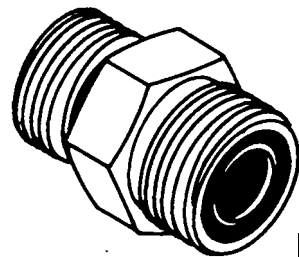

M82651A

FLAT FACE O-RING SEAL FITTING TORQUE

Nominal Tube O.D.		Dash Size	Thread Size (in.)	Swivel Nut Torque		Bulkhead Nut Torque	
mm	(in.)			N•m	(lb-ft)	N•m	(lb-ft)
6.35	0.250	-4	9/16-18	16	12	5.0	3.5
9.52	0.375	-6	11/16-16	24	18	9.0	6.5
12.70	0.500	-8	13/16-16	50	51	17.0	12.5
15.88	0.625	-10	1-14	69	51	17.0	12.5
19.05	0.750	-12	1-3/16-12	102	75	17.0	12.5
22.22	0.875	-14	1-3/16-12	102	75	17.0	12.5
25.40	1.000	-16	1-7/16-12	142	105	17.0	12.5
31.75	1.250	-20	1-11/16-12	190	140	17.0	12.5
38.10	1.500	-24	2-12	217	160	17.0	12.5

NOTE: Torque tolerance is +15 -20%.

GASOLINE

C CAUTION

Handle fuel with care, it is highly flammable. DO NOT refuel machine:

- Indoors. Always fill fuel tank outdoors.
- While you smoke.
- When machine is near an open flame or sparks.
- When engine is running. STOP engine.
- When engine is hot. Allow to cool.

Help prevent fires:

- Fill fuel tank only to bottom of filler neck.
- Clean oil, grease and dirt from machine.
- Clean up spilled fuel immediately.
- Do not store machine with fuel in tank in a building where fumes may reach an open flame or spark.

To prevent fire and explosion caused by static electric discharge while you fill tank:

- Use approved, non-metal fuel container.
- When using a funnel, MAKE SURE it is PLASTIC.
- Avoid using a funnel which has a metal screen or filter.

IMPORTANT: To avoid engine damage:

- DO NOT mix oil with gasoline.
- Use only clean approved containers and funnels.
- Store oil and fuel in an area protected from dust, moisture and other contamination.

Unleaded fuel is recommended because it burns cleaner and leaves less unburned deposits in engine combustion chamber. Regular leaded gasoline with an anti-knock index of 87 or higher may be used. Use of gasohol is acceptable as long as the ethyl alcohol blend does not exceed 11 percent. Unleaded gasohol is preferred over leaded gasohol.

Fill fuel tank at the end of each day's operation. Fill only to bottom of filler neck. Fuel tank capacity is 10.4 L (2.75 U.S. gal).

FUEL STORAGE

Keep fuel in a clean container in a protected area. Water and sediment must be bromated before fuel gets to the engine. Do not use deicers to remove water from fuel. Do not depend on fuel filters to remove water.

If possible, install a water separator at the storage tank outlet.

IMPORTANT: Keep all dirt, scale, water or other foreign material out of fuel.



If machine is stored during the winter, add TY6295 John Deere Gasoline Storage Stabilizer or an equivalent to the fuel. Follow directions on the can.

ENGINE OIL

Use oil viscosity based on the expected air temperature range during the period between oil changes.

The following oil is preferred:

- John Deere PLUS-4®.

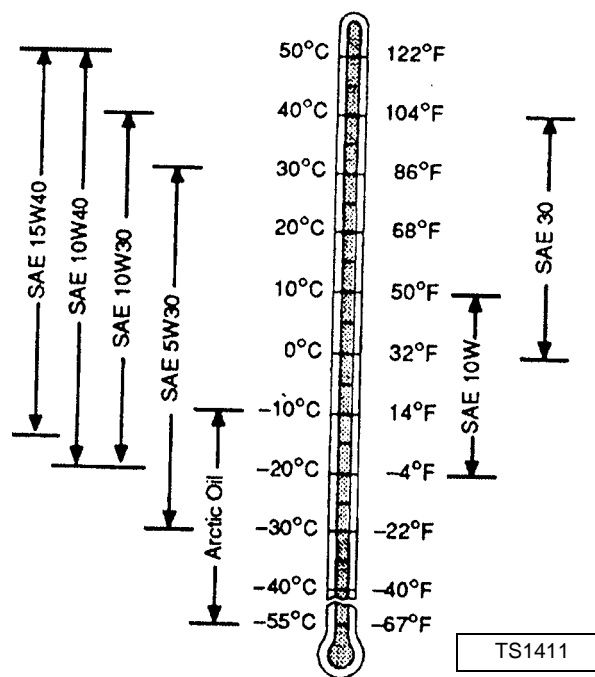

Other oils may be used if they meet one of the following:

- API Service Classification SG
- API Service Classification SF
- CCMC Specification G4

Oils meeting Military Specification MIL-L-46167B may be used as arctic oils.

ENGINE COOLANT—345

Use ethylene glycol base coolant. These coolants usually have labels stating “For Automobile and Light Duty Service.” These product are also often labels for use in aluminum engines. Check container label before using.



IMPORTANT: To prevent engine damage, DO NOT use pure antifreeze or more than 50 percent antifreeze in the cooling system. DO NOT mix or add any other type additives to the cooling system.

Mix approximately 50 percent antifreeze with 50 percent distilled or deionized water. This mixture will provide freeze protection to -37° C (-34° F).

Certain geographical areas may require lower temperature protection. See the label on your antifreeze container or consult your John Deere dealer to obtain the latest information and recommendations.

The recommended antifreeze provides:

- Adequate heat transfer.
- Corrosion-resistant environment within the cooling system.
- Compatibility with cooling system hose and seal material.
- Protection during cold and hot weather operations.

OILSCAN® AND COOLSCAN™

OILSCAN and COOLSCAN are John Deere sampling programs to help you monitor machine performance and identify potential problems before they cause serious damage.

Oil and coolant samples should be taken from each system prior to its recommended change interval.

Check with your John Deere dealer for the availability of OILSCAN and COOLSCAN kits.

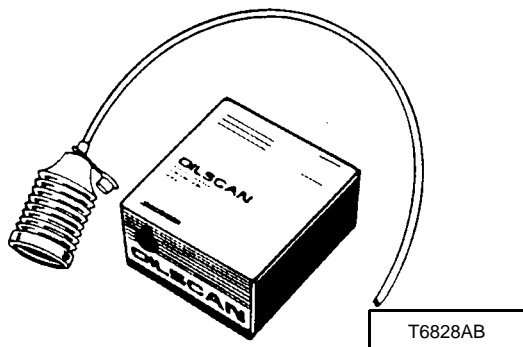

T6828AB

GREASE

Use grease based on the expected air temperature range during the service interval.

The following greases are preferred:

- John Deere MOLY HIGH TEMPERATURE EP GREASE
- John Deere HIGH TEMPERATURE EP GREASE
- John Deere GREASE-GARD™

Other greases may be used if they meet one of the following:

- SAE Multipurpose EP Grease with a maximum of 5% molybdenum disulfide
- SAE Multipurpose EP Grease

Grease meeting Military Specification MIL-G-10294F may be used as arctic grease.

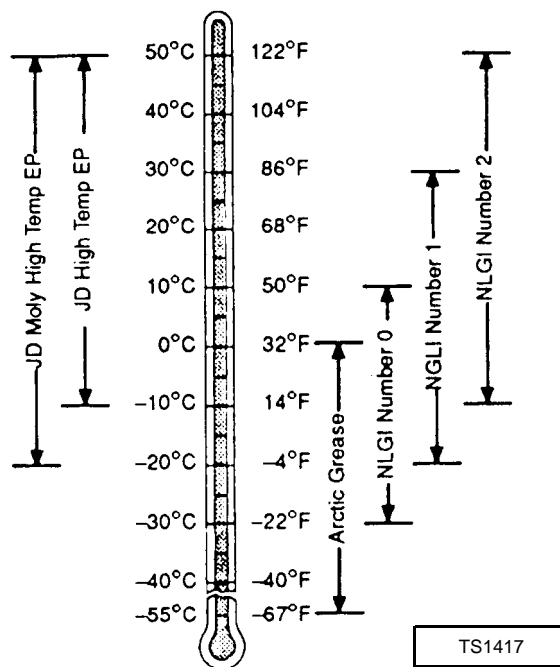

TS1417

ANTI-CHATTER TRANSMISSION OIL

NOTE: This transmission is filled with John Deere Low Viscosity HY-GARD® (J20D) transmission oil at the factory. DO NOT mix oils.

This machine is equipped with an internal wet disc brake transmission. To avoid chatter, use only Low Viscosity HY-GARD® (J20D) transmission oil. It is specifically formulated to minimize wet brake chatter, and to provide maximum protection against mechanical wear, corrosion and foaming.

DO NOT use type "F" automatic transmission fluid.

IMPORTANT: When operating in temperatures below -7°C (-20°F), Low Viscosity HY-GARD® must be used or transmission will be noisy.

ALTERNATIVE LUBRICANTS

Conditions in certain geographical areas outside the United States and Canada may require different lubricant recommendations than these printed in this manual or the operator's manual. Consult with your John Deere Dealer, or Sales Branch to obtain the alternative lubricant recommendations.

SYNTHETIC LUBRICANTS

Synthetic lubricants may be used in John Deere equipment if they meet the applicable performance requirements (industry classification and/or military specification).

The recommended temperature limits and service or oil change intervals should be maintained as shown in the operator's manual.

Avoid mixing different brands, grades or types of oil. Oil manufacturers blend additives in their oils to meet certain specifications and performance requirements. Mixing different oils can interfere with the proper functioning of these additives and degrade lubricant performance.

OIL FILTERS

Filtration of oils is critical to proper lubrication. Always change filter regularly.

Use filters meeting John Deere performance specifications.

LUBRICANT STORAGE

This machine can operate at top efficiency only if clean lubricants are used.

Use clean containers to handle all lubricants. Store them in an area protected from dust, moisture and other contamination. Store drum on their sides.



SERIAL NUMBER LOCATION

When ordering parts or submitting a warranty claim, it is IMPORTANT that the machine product identification number and component serial numbers are included.



The location of the machine identification number and component serial numbers are shown.

MACHINE IDENTIFICATION NUMBER

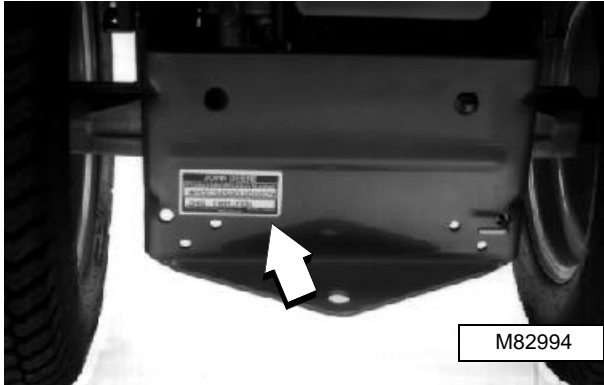

ENGINE SERIAL NUMBER

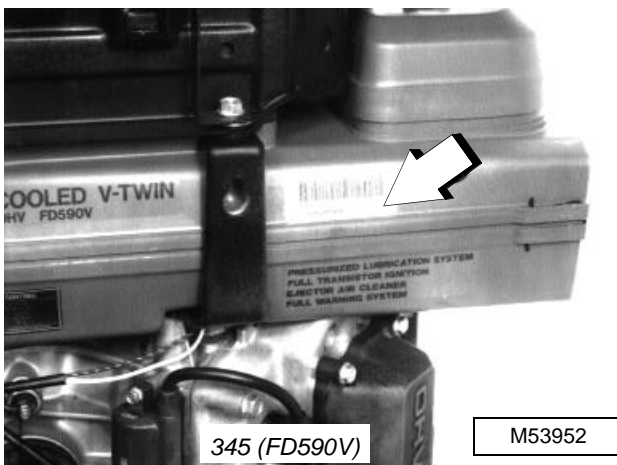
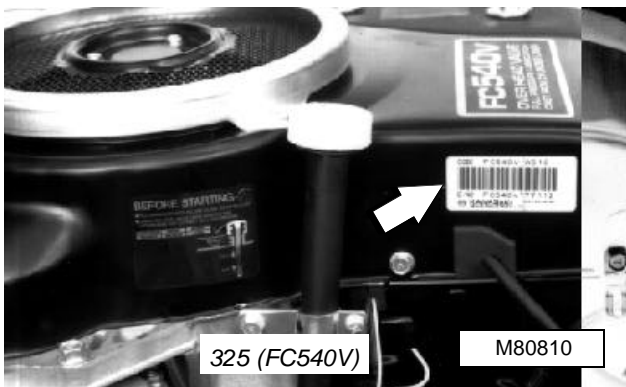

CARBURETOR SERIAL NUMBER

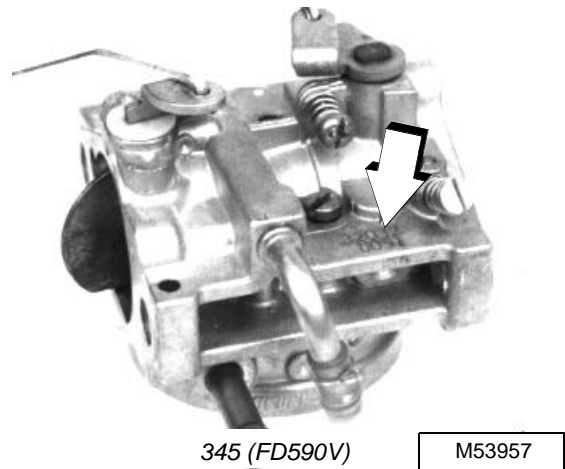
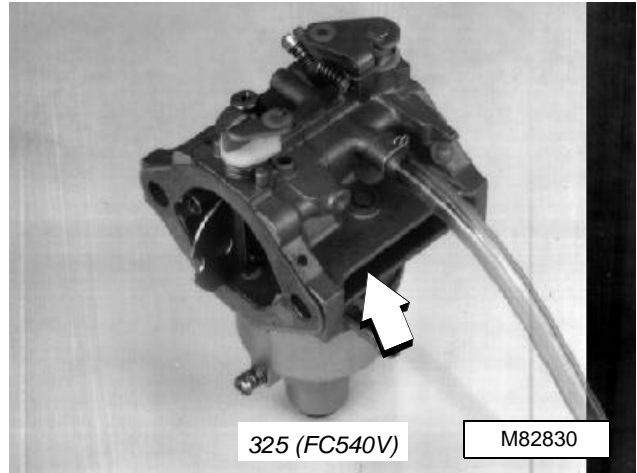

HYDROSTATIC TRANSMISSION SERIAL NUMBER

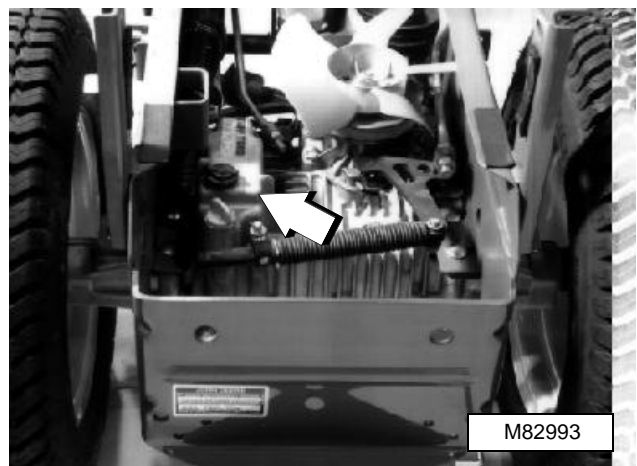

MOWER DECK SERIAL NUMBER



M82828

38, 48 and 54-Inch Mower Decks

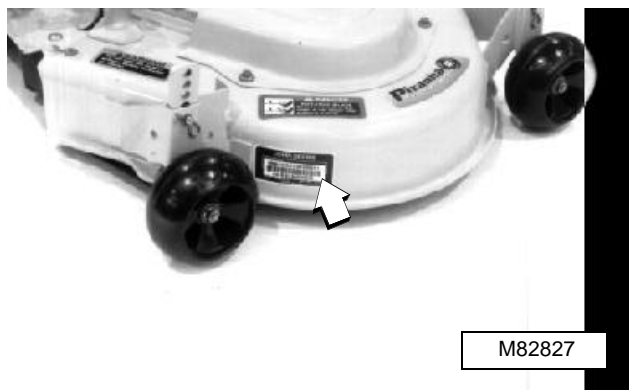

M82827

44-Inch Rear Discharge Mower Deck



This page intentionally left blank.

CONTENTS

	Page
SPECIFICATIONS	
ENGINE DESIGNATION	2-4
TEST AND ADJUSTMENT SPECIFICATIONS	2-4
REPAIR SPECIFICATIONS	2-4
SPECIAL OR ESSENTIAL TOOLS	2-7
OTHER MATERIALS	2-8
SERVICE PARTS KITS	2-8
COMPONENT LOCATION	
EXTERIOR ENGINE COMPONENTS	2-9
INTERNAL ENGINE COMPONENTS	2-10
OIL PUMP, BREATHER AND COMPRESSION RELEASE COMPONENTS	2-11
FUEL AND AIR SYSTEM COMPONENTS	2-12
TROUBLESHOOTING	
ENGINE AND FUEL SYSTEM TROUBLESHOOTING CHART	2-13
ENGINE TROUBLESHOOTING GUIDE	2-15
STARTER MOTOR TROUBLESHOOTING GUIDE	2-19
CHECKS, TESTS AND ADJUSTMENTS	
THROTTLE CABLE CHECK AND ADJUSTMENT	2-20
CHOKE PLATE CHECK AND ADJUSTMENT	2-20
GOVERNOR ADJUSTMENT	2-22
FAST IDLE SPEED ADJUSTMENT	2-22
SLOW IDLE SPEED ADJUSTMENT	2-23
CYLINDER COMPRESSION PRESSURE TEST	2-24
VALVE CLEARANCE, CHECK AND ADJUSTMENT	2-24
AUTOMATIC COMPRESSION RELEASE (ACR) CHECK	2-25
CRANKCASE VACUUM TEST	2-25
ENGINE OIL PRESSURE TEST	2-26
FUEL PUMP TEST	2-27
CRANKSHAFT END PLAY CHECK	2-28
SPARK TEST	2-28
SPARK PLUG GAP ADJUSTMENT	2-29
REPAIR	
FUEL TANK	2-30
THROTTLE CONTROL LEVER AND CABLE	2-30
ENGINE	
Removal/Installation	2-30
MUFFLER	2-32
AIR CLEANER ASSEMBLY	2-32



REPAIR, continued

CARBURETOR	
Removal/Installation	2-33
Disassembly/Assembly	2-33
Clean/Inspect/Rebuild	2-34
FUEL PUMP	2-34
BREATHER	2-34
BLOWER HOUSING	
Inspection/Replacement	2-36
Flywheel Screen Adjustment.	2-36
FLYWHEEL	2-36
ROCKER ARM ASSEMBLY	
Removal/Installation	2-37
Inspection	2-37
CYLINDER HEAD AND VALVES	
Removal/Installation	2-37
Disassembly/Assembly	2-38
Inspection	2-38
Valve Guide Replacement.	2-36
ANALYZE VALVES	2-40
RECONDITION VALVE SEATS	2-41
LAP VALVES	2-42
CRANKCASE COVER	2-42
PISTON AND CONNECTING ROD	
Removal	2-43
Installation.	2-43
Disassembly	2-43
Assembly.	2-44
Inspection	2-44
ANALYZE PISTON RING WEAR.	2-46
ANALYZE PISTON WEAR.	2-47
ANALYZE CRANKSHAFT AND CONNECTING ROD WEAR.	2-48
CAMSHAFT AND TAPPETS	
Removal	2-48
Installation.	2-49
Inspection	2-49
RECIPROCATING BALANCER	
Removal/Installation	2-50
Disassembly/Assembly	2-51
Inspection	2-51
Bushing Replacement.	2-52



REPAIR, continued

CRANKSHAFT AND MAIN BEARINGS	
Removal/Installation	2-52
Inspection	2-52
End Play Adjustment.	2-54
CRANKSHAFT OIL SEAL - FLYWHEEL END	2-54
CRANKSHAFT OIL SEAL - PTO END	2-55
ANALYZE CRANKSHAFT AND CONNECTING ROD WEAR.	2-55
CYLINDER BLOCK	
Inspection	2-55
Deglaze Cylinder Bore	2-56
Resize Cylinder Bore	2-56
OIL PUMP	
Disassembly/Assembly	2-57
Inspection	2-57
OIL FILTER MANIFOLD	2-59
GOVERNOR	2-59
GOVERNOR SHAFT.	2-59
STATOR.	2-60
ARMATURE WITH COIL	
Removal/Installation	2-60
Test	2-60
Air Gap Adjustment.	2-61
STARTER	
Analyze Condition.	2-61
No-Load Amperage Draw and RPM Test	2-61
Disassembly/Assembly	2-61
Inspection/Test	2-62



ENGINE DESIGNATION

FC 540 V

Four Cycle

Model Designation/
Variation A, B, C, D, etc.

Displacement

V - Vertical
G - Gear Drive off Camshaft
R - Gear Box Drive
D - Direct Drive



TEST AND ADJUSTMENT SPECIFICATIONS

Fast Idle	3350 ± 50 rpm
Slow Idle	
Throttle control arm SLOW idle stop screw setting	100 rpm higher than carburetor setting
Carburetor SLOW idle stop screw setting	1550 ± 75 rpm
Minimum Cylinder Compression Pressure	.483 kPa (71 psi)
Valve Clearance (cold)	0.15 mm (0.006 in.)
Valve Adjustment Screw Jam Nut Torque	.9 N•m (79 lb-in.)
Valve Cover Cap Screw Torque	.6 N•m (53 lb-in.)
Minimum Exhaust Valve ACR Movement	0.25 mm (0.010 in.)
Minimum Crankcase Vacuum	.25 cm (10 in.) water
Minimum Engine Oil Pressure:	
Fast Idle (3350 ± 50 rpm)	.240 kPa (35 psi)
Slow Idle (1450 ± 75 rpm)	.28 kPa (4 psi)
Fuel Pump Minimum Pressure	.6.12 kPa (0.90 psi)
Fuel Pump Minimum Flow	65 ml/15 seconds (2.2 oz/15 seconds)
Crankshaft End Play	0.09—0.22 mm (0.004—0.009 in.)
Spark Plug Gap	0.76 mm (0.030 in.)
Spark Plug Torque	.20 N•m (177 lb-in.)

REPAIR SPECIFICATIONS

Engine Oil Capacity	
Without Filter	1.6 L (3.4 U.S. pt)
With Filter	1.8 L (3.8 U.S. pt)
Engine Mounting Cap Screw Torque	.16 N•m (144 lb-in.)
Breather Air Gap	1—2 mm (0.040—0.080 in.)
Valve Adjustment Screw Jam Nut Torque	.9 N•m (79 lb-in.)
Valve Cover Cap Screw Torque	.6 N•m (53 lb-in.)
Flywheel Screen Minimum Gap	1.5 mm (0.059 in.)
Flywheel Nut Torque	.172 N•m (127 lb-ft)
Rocker Arm Assembly	
Minimum Shaft O.D.	12.94 mm (0.509 in.)
Maximum Bearing I.D.	13.07 mm (0.515 in.)
Maximum Push Rod Bend	0.30 mm (0.012 in.)

REPAIR SPECIFICATIONS, continued

Cylinder Head and Valves

Cap Screw Torque in Sequence (Lubricated)

Initial Torque32 N•m (24 lb-ft)

Final Torque52 N•m (38 lb-ft)

Spark Plug Torque.20 N•m (177 lb-in.)

Cylinder Head Flatness (Maximum)0.05 mm (0.002 in.)

Maximum Valve Guide I.D.7.07 mm (0.278 in.)

Valve Seating Surface1.10—1.46 mm (0.043—0.057 in.)

Minimum Spring Free Length37.50 mm (1.476 in.)

Minimum Valve Margin0.60 mm (0.024 in.)

Maximum Valve Stem Bend0.03 mm (0.001 in.)

Valve Guide Installation Depth9.5 mm (0.370 in.)

Finished Valve Guide ID. (Reamed)7.00—7.02 mm (0.275—0.276 in.)

Valve Seat and Face Angle45°

Valve Narrowing Angle30°

Crankcase Cover

Oil Capacity

Without Filter.1.6 L (3.4 U.S. pt)

With Filter1.8 L (3.8 U.S. pt)

Mounting Cap Screw Torque26 N•m (230 lb-in.)

Oil Drain Plug Torque23 N•m (200 lb-in.)

Piston

Connecting Rod Cap Screw Torque20 N•m (177 lb-in.)

Maximum Ring Groove Side Clearance

Top Ring0.17 mm (0.007 in.)

Second Ring0.15 mm (0.006 in.)

Oil Ring0.20 mm (0.008 in.)

Minimum Pin O.D.21.98 mm (0.865 in.)

Maximum Pin Bore O.D.22.04 mm (0.868 in.)

Piston O.D.

Standard Piston88.83—88.864 mm (3.4885—3.4984 in.)

0.50 mm (0.020 in.)

Oversize Piston.89.330—89.364 mm (3.517—3.518 in.)

Cylinder Bore I.D.

Standard88.98—89.00 mm (3.5031—3.5039 in.)

Wear Limit (Maximum)89.08 mm (3.507 in.)

0.50 mm (0.020 in.) Oversize Bore

Standard89.48—89.50 mm (3.5228—3.5236 in.)

Wear Limit(Maximum) 89.58 mm (3.5267 in.)

Connecting Rod

Maximum Crankshaft Bearing I.D.

Standard41.07 mm (1.617 in.)

Undersized40.56 mm (1.597 in.)

Maximum Piston Pin Bearing I.D.22.06 mm (0.868 in.)

Piston Rings

Minimum Ring Thickness (Top and Second Rings)1.94 mm (0.076 in.)

Minimum Ring End Gap0.18 mm (0.007 in.)

Maximum Ring End Gap

Compression Rings (Top and Second)0.90 mm (0.035 in.)

Oil Ring Side Rails1.30 mm (0.051 in.)



REPAIR SPECIFICATIONS, continued

Camshaft

Minimum End Journal O.D.	20.91 mm (0.823 in.)
Minimum Lobe Height.	37.10 mm (1.461 in.)
Maximum Bearing I.D.	21.08 mm (0.830 in.)

Reciprocating Balancer

Support Shaft Nut Torque.	7 N•m (65 lb-in.)
-----------------------------------	-------------------

Link Rod

Minimum Journal O.D.	57.94 mm (2.281 in.)
Maximum Small End I.D.	12.06 mm (0.475 in.)
Maximum Large End I.D.	58.15 mm (2.289 in.)

Balancer Weight

Maximum Bearing I.D.	26.10 mm (1.027 in.)
Bushing Depth	0.50 mm (0.020 in.)

Support Shaft

Minimum Shaft O.D.	25.93 mm (1.021 in.)
----------------------------	----------------------

Crankshaft

Maximum T.I.R.	0.05 mm (0.002 in.)
Minimum Main Bearing Journal O.D.	37.90 mm (1.492 in.)
Minimum Connecting Rod Journal O.D.	
Standard.	40.93 mm (1.611 in.)
Undersized.	40.43 mm (1.591 in.)
Maximum Crankcase Cover Plain Bearing I.D.	38.06 mm (1.498 in.)

PTO Side Oil Seal Depth	0.50 mm (0.020 in.)
-----------------------------------	---------------------

Oil Pump

Minimum Rotor Shaft O.D.	12.63 mm (0.497 in.)
Maximum Rotor Shaft Bearing I.D.	12.76 mm (0.502 in.)

Outer Rotor

Minimum Thickness	9.92 mm (0.391 in.)
Minimum O.D.	40.47 mm (1.596 in.)

Outer Rotor Bearing

Minimum Depth	10.17 mm (0.401 in.)
Maximum I.D.	40.77 mm (1.605 in.)

Minimum Valve Spring Free Length	19.00 mm (0.750 in.)
--	----------------------

Governor

Governor Mounting Shaft Height	32.2—32.8 mm (1.267—1.291 in.)
Governor Lever Nut Torque	7.8 N•m (69 lb-in.)

Armature with Coil

Resistance between primary lead and core	0.48—0.72 ohms
Resistance between plug cap and core	10.9—16.3 Kohms
Air Gap	0.30 mm (0.012 in.)

Starter

Maximum Amperage (No Load)	50 amps at 5000 rpm
Minimum Brush Length.	10.5 mm (0.413 in.)



Product: John Deere 325 and 345 Lawn and Garden Tractors Service Repair Technical Manual

Full Download: <https://www.bobmanualstore.com/downloads/john-deere-325-and-345-lawn-and-garden-tractors-service-repair-technical-manual>

SPECIAL OR ESSENTIAL TOOLS

/NOTE: Order tools according to information given in the U.S. SERVICE-GARD™ Catalog or in the European Microfiche Tool Catalog (MTC).

JT05719 Hand-Held Digital Tachometer

Used to check idle speed and starter performance.

JDM59 Compression Gauge

Used to check engine compression.

8741-F66 Plug

Used to connect U-tube manometer to engine for Crankcase Vacuum Test.

JT05703 Barb Fitting

Used to connect U-tube manometer to engine for Crankcase Vacuum Test.

JT05699 Line

Used to connect U-tube manometer to engine for Crankcase Vacuum Test.

JT05698 U-Tube Manometer

Used to check engine crankcase vacuum.

JT03338 90° Elbow Fitting

Used to connect pressure gauge to engine when performing Engine Oil Pressure Test.

JT03017 Hose Assembly

Used to connect pressure gauge to engine when performing Engine Oil Pressure Test.

JT03344 Pressure Gauge Assembly

Used to read engine oil pressure when performing Engine Oil Pressure Test.

JDG356 Pressure Gauge

Used to check fuel pump performance.

D-05351ST Spark Tester

Used to check overall condition of ignition system.

JDM70 Valve Spring Compressor

Used to remove and install valve springs.

JDG504 Valve Guide Driver Tool

Used to replace valve guide bushings.

JT05712 Current Gun

Used to check starter performance.

