

Product: John Deere TS and TH 6x4 Gator Utility Vehicle Service Repair Technical Manual

Full Download: <https://www.bobmanualstore.com/downloads/john-deere-ts-and-t>

[h-6x4-gator-utility-vehicle-service-repair-technical-manual/](https://www.bobmanualstore.com/downloads/john-deere-ts-and-t-h-6x4-gator-utility-vehicle-service-repair-technical-manual/)

JOHN DEERE
WORLDWIDE COMMERCIAL & CONSUMER
EQUIPMENT DIVISION

Gator Utility Vehicle
TS and TH 6x4

TM2239 OCTOBER 2004

TECHNICAL MANUAL



JOHN DEERE

North American Version
Litho in U.S.A.

Sample manual. Download All 384 pages at:

<https://www.bobmanualstore.com/downloads/john-deere-ts-and-th-6x4-gator-utility-vehicle-service-repair-technical-manual/>

Product: John Deere TS and TH 6x4 Gator Utility Vehicle Service Repair Technical Manual

Full Download: <https://www.bobmanualstore.com/downloads/john-deere-ts-and-t>

[h-6x4-gator-utility-vehicle-service-repair-technical-manual/](https://www.bobmanualstore.com/downloads/john-deere-ts-and-t-h-6x4-gator-utility-vehicle-service-repair-technical-manual/)

Sample manual. Download All 384 pages at:

<https://www.bobmanualstore.com/downloads/john-deere-ts-and-th-6x4-gator-utility-vehicle-service-repair-technical-manual/>

INTRODUCTION

Manual Description

This technical manual is written for an experienced technician and contains sections that are specifically for this product. It is a part of a total product support program.

The manual is organized so that all the information on a particular system is kept together. The order of grouping is as follows:

- Table of Contents
- Specifications and Information
- Identification Numbers
- Tools and Materials
- Component Location
- Schematics and Harnesses
- Theory of Operation
- Operation and Diagnostics
- Diagnostics
- Tests and Adjustments
- Repair
- Other

NOTE: Depending on the particular section or system being covered, not all of the above groups may be used.

The bleed tabs for the pages of each section will align with the sections listed on this page. Page numbering is consecutive from the beginning of the Safety section through the last section.

We appreciate your input on this manual. If you find any errors or want to comment on the layout of the manual please contact us.

Safety

Specifications and Information

Engine - Gas (10 Hp)

Engine - Gas (19 Hp)

Electrical

Power Train

Steering

Brakes

Miscellaneous

All information, illustrations and specifications in this manual are based on the latest information at the time of publication. The right is reserved to make changes at any time without notice.

COPYRIGHT© 2004
Deere & Co.
John Deere Worldwide Commercial and
Consumer Equipment Division
All rights reserved
Previous Editions
COPYRIGHT©

INTRODUCTION

SAFETY

Recognize Safety Information



MIF

This is the safety-alert symbol. When you see this symbol on your machine or in this manual, be alert to the potential for personal injury.

Follow recommended precautions and safe servicing practices.

Understand Signal Words

A signal word - DANGER, WARNING, or CAUTION - is used with the safety-alert symbol. DANGER identifies the most serious hazards.

DANGER or WARNING safety signs are located near specific hazards. General precautions are listed on CAUTION safety signs. CAUTION also calls attention to safety messages in this manual.

Replace Safety Signs

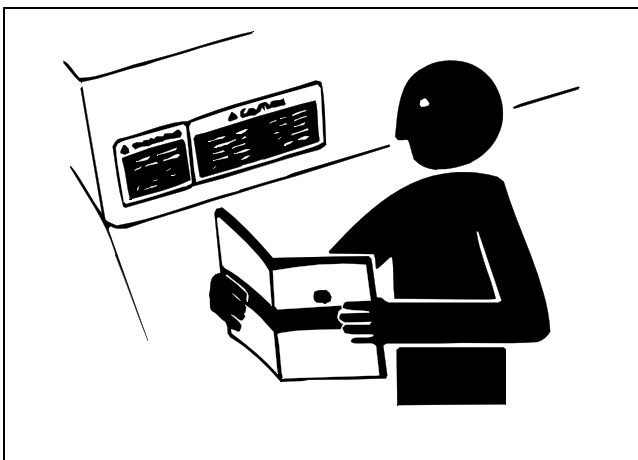

MIF

Replace missing or damaged safety signs. See the machine operator's manual for correct safety sign placement.

Handle Fluids Safely - Avoid Fires

Be Prepared For Emergencies

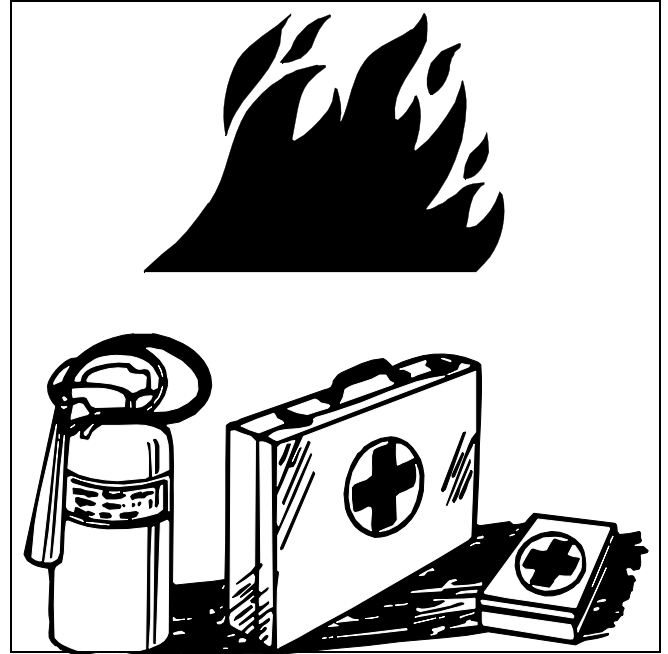

MIF

- When you work around fuel, do not smoke or work near heaters or other fire hazards.
- Store flammable fluids away from fire hazards. Do not incinerate or puncture pressurized containers.
- Make sure machine is clean of trash, grease, and debris.
- Do not store oily rags; they can ignite and burn spontaneously.
- Be prepared if a fire starts.
- Keep a first aid kit and fire extinguisher handy.
- Keep emergency numbers for doctors, ambulance service, hospital, and fire department near your telephone.

Use Care In Handling and Servicing Batteries

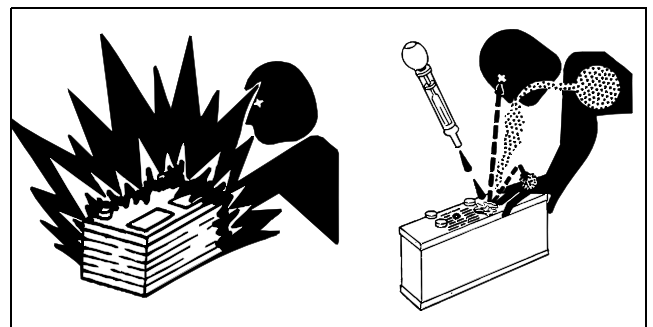

MIF

SAFETY

Prevent Battery Explosions

- Keep sparks, lighted matches, and open flame away from the top of battery. Battery gas can explode.
- Never check battery charge by placing a metal object across the posts. Use a volt-meter or hydrometer.
- Do not charge a frozen battery; it may explode. Warm battery to 16°C (60°F).

Prevent Acid Burns

- Sulfuric acid in battery electrolyte is poisonous. It is strong enough to burn skin, eat holes in clothing, and cause blindness if splashed into eyes.

Avoid acid burns by:

1. Filling batteries in a well-ventilated area.
2. Wearing eye protection and rubber gloves.
3. Avoiding breathing fumes when electrolyte is added.
4. Avoiding spilling or dripping electrolyte.
5. Use proper jump start procedure.

If you spill acid on yourself:

1. Flush your skin with water.
2. Apply baking soda or lime to help neutralize the acid.
3. Flush your eyes with water for 10 - 15 minutes.
4. Get medical attention immediately.

If acid is swallowed:

1. Drink large amounts of water or milk.
2. Then drink milk of magnesia, beaten eggs, or vegetable oil.
3. Get medical attention immediately.

Wear Protective Clothing

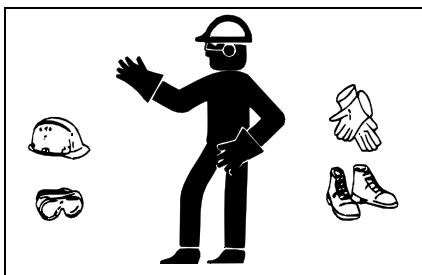

MIF

Wear close fitting clothing and safety equipment appropriate to the job.

Prolonged exposure to loud noise can cause impairment or loss of hearing. Wear a suitable hearing protective device

such as earmuffs or earplugs to protect against objectionable or uncomfortable loud noises.

Operating equipment safely requires the full attention of the operator. Do not wear radio or music headphones while operating machine.

Use Care Around High-pressure Fluid Lines

Avoid High-Pressure Fluids



MIF

Escaping fluid under pressure can penetrate the skin causing serious injury.

Avoid injury from escaping fluid under pressure by stopping the engine and relieving pressure in the system before disconnecting or connecting hydraulic or other lines. Tighten all connections before applying pressure.

Search for leaks with a piece of cardboard. Protect hands and body from high pressure fluids.

If an accident occurs, see a doctor immediately. Any fluid injected into the skin must be surgically removed within a few hours or gangrene may result. Doctors unfamiliar with this type of injury should reference a knowledgeable medical source. Such information is available from Deere & Company Medical Department in Moline, Illinois, U.S.A.

Avoid Heating Near Pressurized Fluid Lines



MIF

Flammable spray can be generated by heating near pressurized fluid lines, resulting in severe burns to yourself and bystanders. Do not heat by welding, soldering, or using a torch near pressurized fluid lines or other flammable materials. Pressurized lines can be accidentally cut when heat goes beyond the immediate flame area.

SAFETY

Service Machines Safely

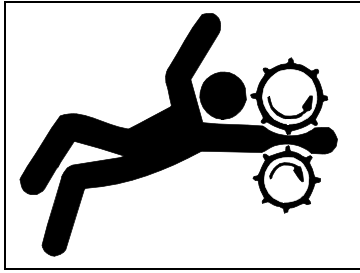

MIF

Tie long hair behind your head. Do not wear a necktie, scarf, loose clothing, or necklace when you work near machine tools or moving parts. If these items were to get caught, severe injury could result.

Remove rings and other jewelry to prevent electrical shorts and entanglement in moving parts.

Use Proper Tools

Use tools appropriate to the work. Makeshift tools and procedures can create safety hazards. Use power tools only to loosen threaded parts and fasteners. For loosening and tightening hardware, use the correct size tools. **DO NOT** use U.S. measurement tools on metric fasteners. Avoid bodily injury caused by slipping wrenches. Use only service parts meeting John Deere specifications.

Parking Safely

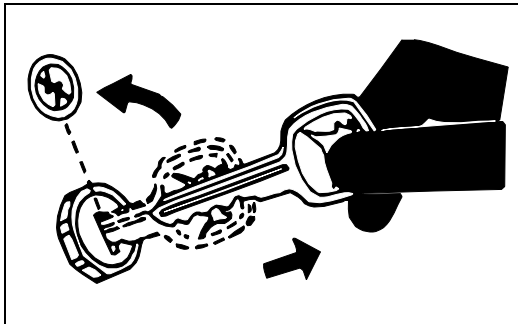

MIF

1. Stop machine on a level surface, not on a slope.
2. Disengage and stop attachments.
3. Lower attachments to the ground.
4. Lock park brake.
5. Stop engine.
6. Remove key.
7. Wait for engine and all moving parts to stop before you leave the operator's station.
8. Close fuel shut-off valve, if your machine is equipped.

Support Machine Properly and Use Proper Lifting Equipment

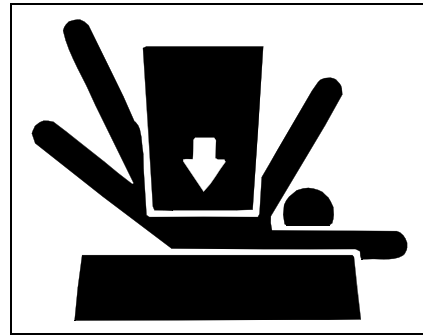

MIF

If you must work on a lifted machine or attachment, securely support the machine or attachment.

Do not support the machine on cinder blocks, hollow tiles, or props that may crumble under continuous load. Do not work under a machine that is supported solely by a jack. Follow recommended procedures in this manual.

Lifting heavy components incorrectly can cause severe injury or machine damage. Follow recommended procedure for removal and installation of components in the manual.

Work In Clean Area

Before starting a job:

1. Clean work area and machine.
2. Make sure you have all necessary tools to do your job.
3. Have the right parts on hand.
4. Read all instructions thoroughly; do not attempt shortcuts.

Using High Pressure Washers

Directing pressurized water at electronic/electrical components or connectors, bearings, hydraulic seals, fuel injection pumps or other sensitive parts and components may cause product malfunctions. Reduce pressure and spray at a 45 to 90 degree angle.

Illuminate Work Area Safely

Illuminate your work area adequately but safely. Use a portable safety light for working inside or under the machine. Make sure the bulb is enclosed by a wire cage. The hot filament of an accidentally broken bulb can ignite spilled fuel or oil.

SAFETY

Work In Ventilated Area

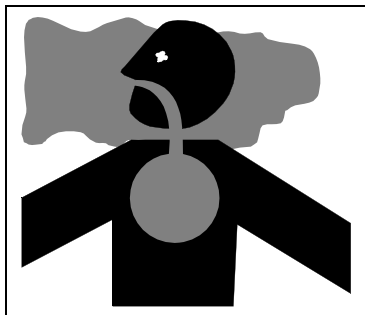

MIF

Engine exhaust fumes can cause sickness or death. If it is necessary to run an engine in an enclosed area, remove the exhaust fumes from the area with an exhaust pipe extension.

If you do not have an exhaust pipe extension, open the doors and get outside air into the area.

Warning: California Proposition 65 Warning

Gasoline engine exhaust from this product contains chemicals known to the State of California to cause cancer, birth defects, or other reproductive harm.

Diesel engine exhaust and some of its constituents are known to the State of California to cause cancer, birth defects, and other reproductive harm.

Remove Paint Before Welding or Heating

Avoid potentially toxic fumes and dust. Hazardous fumes can be generated when paint is heated by welding, soldering, or using a torch. Do all work outside or in a well ventilated area. Dispose of paint and solvent properly. Remove paint before welding or heating: If you sand or grind paint, avoid breathing the dust. Wear an approved respirator. If you use solvent or paint stripper, remove stripper with soap and water before welding. Remove solvent or paint stripper containers and other flammable material from area. Allow fumes to disperse at least 15 minutes before welding or heating.

Avoid Harmful Asbestos Dust

Avoid breathing dust that may be generated when handling components containing asbestos fibers. Inhaled asbestos fibers may cause lung cancer.

Components in products that may contain asbestos fibers are brake pads, brake band and lining assemblies, clutch plates, and some gaskets. The asbestos used in these components is usually found in a resin or sealed in some way. Normal handling is not hazardous as long as airborne dust containing asbestos is not generated.

Avoid creating dust. Never use compressed air for cleaning. Avoid brushing or grinding material containing asbestos. When servicing, wear an approved respirator. A special vacuum cleaner is recommended to clean asbestos. If not available, apply a mist of oil or water on the material containing asbestos. Keep bystanders away from the area.

Service Tires Safely



MIF

Explosive separation of a tire and rim parts can cause serious injury or death.

Do not attempt to mount a tire unless you have the proper equipment and experience to perform the job.

Always maintain the correct tire pressure. Do not inflate the tires above the recommended pressure. Never weld or heat a wheel and tire assembly. The heat can cause an increase in air pressure resulting in a tire explosion. Welding can structurally weaken or deform the wheel.

When inflating tires, use a clip-on chuck and extension hose long enough to allow you to stand to one side and NOT in front of or over the tire assembly. Use a safety cage if available.

Check wheels for low pressure, cuts, bubbles, damaged rims or missing lug bolts and nuts.

SAFETY

Avoid Injury From Rotating Blades, Augers and PTO Shafts

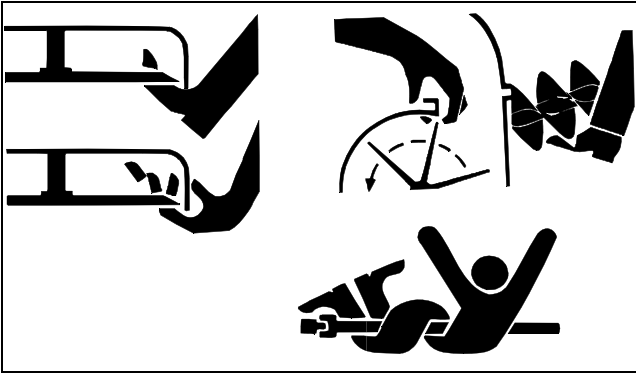

MIF

Keep hands and feet away while machine is running. Shut off power to service, lubricate or remove mower blades, augers or PTO shafts.

Service Cooling System Safely

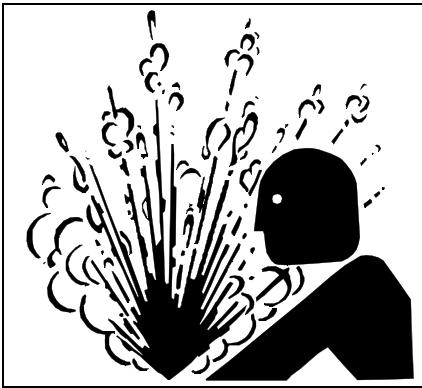

MIF

Explosive release of fluids from pressurized cooling system can cause serious burns.

Shut off machine. Only remove filler cap when cool enough to touch with bare hands. Slowly loosen cap to first stop to relieve pressure before removing completely.

Handle Chemical Products Safely

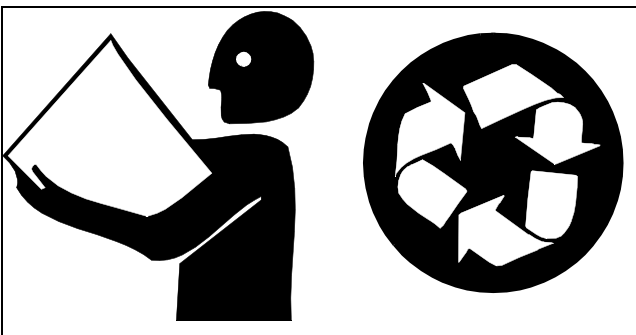

MIF

Direct exposure to hazardous chemicals can cause serious injury. Potentially hazardous chemicals used with John Deere equipment include such items as lubricants, coolants, paints, and adhesives.

A Material Safety Data Sheet (MSDS) provides specific details on chemical products: physical and health hazards, safety procedures, and emergency response techniques. Check the MSDS before you start any job using a hazardous chemical. That way you will know exactly what the risks are and how to do the job safely. Then follow procedures and recommended equipment.

Dispose of Waste Properly

Improperly disposing of waste can threaten the environment and ecology. Potentially harmful waste used with John Deere equipment include such items as oil, fuel, coolant, brake fluid, filters, and batteries. Use leakproof containers when draining fluids. Do not use food or beverage containers that may mislead someone into drinking from them. Do not pour waste onto the ground, down a drain, or into any water source. Inquire on the proper way to recycle or dispose of waste from your local environmental or recycling center, or from your John Deere dealer.

Live With Safety



MIF

Before returning machine to customer, make sure machine is functioning properly, especially the safety systems. Install all guards and shields.

SAFETY



SPECIFICATIONS AND INFORMATION TABLE OF CONTENTS

Table of Contents

Fastener Torques	9
Metric Fastener Torque Values	9
Inch Fastener Torque Values	10
O-Ring Seal Service Recommendations	11
Face Seal Fittings With Inch Stud Ends	
Torque	11
Face Seal Fittings With Metric Stud Ends	
Torque	12
O-Ring Face Seal Fittings	13
O-Ring Boss Fittings	13
Straight Fitting Or Special Nut Torques.....	14
Metric Fastener Torque Value - Grade 7 (Special)	14
General Information	14
Gasoline	14
Gasoline Storage.....	15
4 - Cycle Gasoline Engine Oil	15
Break-In Engine Oil - 4-Cycle Gasoline.....	16
Grease.....	16
Chain Lubricant	16
Transaxle Oil	16
Alternative Lubricants.....	17
Synthetic Lubricants	17
Lubricant Storage	17
Mixing of Lubricants	17
Oil Filters	17
Serial Number Locations	18
Product Serial Number	18
Engine Serial Number Location.....	18
Transaxle Serial Number Location	18

SPECIFICATIONS AND INFORMATION TABLE OF CONTENTS



SPECIFICATIONS AND INFORMATION FASTENER TORQUES

Fastener Torques

Metric Fastener Torque Values

Property Class and Head Markings				
Property Class and Nut Markings				

MIF

SIZE	Class 4.8		Class 8.8 or 9.8				Class 10.9				Class 12.9					
	Lubricated a		Dry a		Lubricated a		Dry a		Lubricated a		Dry a		Lubricated a		Dry a	
	N•m	lb-ft	N•m	lb-ft	N•m	lb-ft	N•m	lb-ft	N•m	lb-ft	N•m	lb-ft	N•m	lb-ft	N•m	lb-ft
M6	4.8	3.5	6	4.5	9	6.5	11	8.5	13	9.5	17	12	15	11.5	19	14.5
M8	12	8.5	15	11	22	16	28	20	32	24	40	30	37	28	47	35
M10	23	17	29	21	43	32	55	40	63	47	80	60	75	55	95	70
M12	40	29	50	37	75	55	95	70	110	80	140	105	130	95	165	120
M14	63	47	80	60	120	88	150	110	175	130	225	165	205	150	260	109
M16	100	73	125	92	190	140	240	175	275	200	350	225	320	240	400	300
M18	135	100	175	125	260	195	330	250	375	275	475	350	440	325	560	410
M20	190	140	240	180	375	275	475	350	530	400	675	500	625	460	800	580
M22	260	190	330	250	510	375	650	475	725	540	925	675	850	625	1075	800
M24	330	250	425	310	650	475	825	600	925	675	1150	850	1075	800	1350	1000
M27	490	360	625	450	950	700	1200	875	1350	1000	1700	1250	1600	1150	2000	1500
M30	675	490	850	625	1300	950	1650	1200	1850	1350	2300	1700	2150	1600	2700	2000
M33	900	675	1150	850	1750	1300	2200	1650	2500	1850	3150	2350	2900	2150	3700	2750
M36	1150	850	1450	1075	2250	1650	2850	2100	3200	2350	4050	3000	3750	2750	4750	3500

DO NOT use these hand torque values if a different torque value or tightening procedure is given for a specific application. Torque values listed are for general use only and include a $\pm 10\%$ variance factor. Check tightness of fasteners periodically. DO NOT use air powered wrenches.

Shear bolts are designed to fail under predetermined loads. Always replace shear bolts with identical grade.

Fasteners should be replaced with the same grade. Make sure fastener threads are clean and that you properly start thread engagement. This will prevent them from failing when tightening.

When bolt and nut combination fasteners are used, torque values should be applied to the NUT instead of the bolt head.







Tighten toothed or serrated-type lock nuts to the full torque value.

a "Lubricated" means coated with a lubricant such as engine oil, or fasteners with phosphate and oil coatings. "Dry" means plain or zinc plated (yellow dichromate - Specification JDS117) without any lubrication.

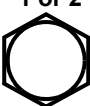
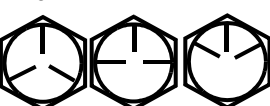
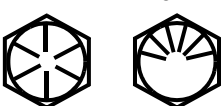
Reference: JDS - G200.

SPECIFICATIONS AND INFORMATION FASTENER TORQUES

Inch Fastener Torque Values

SAE Grade and Head Markings	1 or 2 ^b No Marks 	5 5.1 5.2 	8 8.2 
SAE Grade and Nut Markings	2 No Marks 	5  	8  

MIF

SIZE	Grade 1				Grade 2b				Grade 5, 5.1 or 5.2				Grade 8 or 8.2			
	Lubricated a		Dry a		Lubricated a		Dry a		Lubricated a		Dry a		Lubricated a		Dry a	
	N•m	lb-ft	N•m	lb-ft	N•m	lb-ft	N•m	lb-ft	N•m	lb-ft	N•m	lb-ft	N•m	lb-ft	N•m	lb-ft
1/4	3.7	2.8	4.7	3.5	6	4.5	7.5	5.5	9.5	7	12	9	13.5	10	17	12.5
5/16	7.7	5.5	10	7	12	9	15	11	20	15	25	18	28	21	35	26
3/8	14	10	17	13	22	16	27	20	35	26	44	33	50	36	63	46
7/16	22	16	28	20	35	26	44	32	55	41	70	52	80	58	100	75
1/2	33	25	42	31	53	39	67	50	85	63	110	80	120	90	150	115
9/16	48	36	60	45	75	56	95	70	125	90	155	115	175	130	225	160
5/8	67	50	85	62	105	78	135	100	170	125	215	160	215	160	300	225
3/4	120	87	150	110	190	140	240	175	300	225	375	280	425	310	550	400
7/8	190	140	240	175	190	140	240	175	490	360	625	450	700	500	875	650
1	290	210	360	270	290	210	360	270	725	540	925	675	1050	750	1300	975
1-1/8	470	300	510	375	470	300	510	375	900	675	1150	850	1450	1075	1850	1350
1-1/4	570	425	725	530	570	425	725	530	1300	950	1650	1200	2050	1500	2600	1950
1-3/8	750	550	950	700	750	550	950	700	1700	1250	2150	1550	2700	2000	3400	2550
1-1/2	1000	725	1250	925	990	725	1250	930	2250	1650	2850	2100	3600	2650	4550	3350

DO NOT use these hand torque values if a different torque value or tightening procedure is given for a specific application. Torque values listed are for general use only and include a ±10% variance factor. Check tightness of fasteners periodically. DO NOT use air powered wrenches.

Shear bolts are designed to fail under predetermined loads. Always replace shear bolts with identical grade.

Fasteners should be replaced with the same grade. Make sure fastener threads are clean and that you properly start thread engagement. This will prevent them from failing when tightening.

When bolt and nut combination fasteners are used, torque values should be applied to the NUT instead of the bolt

head.

Tighten toothed or serrated-type lock nuts to the full torque value.

a "Lubricated" means coated with a lubricant such as engine oil, or fasteners with phosphate and oil coatings. "Dry" means plain or zinc plated (yellow dichromate - Specification JDS117) without any lubrication.

b "Grade 2" applies for hex cap screws (Not Hex Bolts) up to 152 mm (6 in.) long. "Grade 1" applies for hex cap screws over 152 mm (6 in.) long, and for all other types of bolts and screws of any length.

Reference: JDS - G200

SPECIFICATIONS AND INFORMATION O-RING SEAL SERVICE

O-Ring Seal Service Recommendations

Face Seal Fittings With Inch Stud Ends Torque

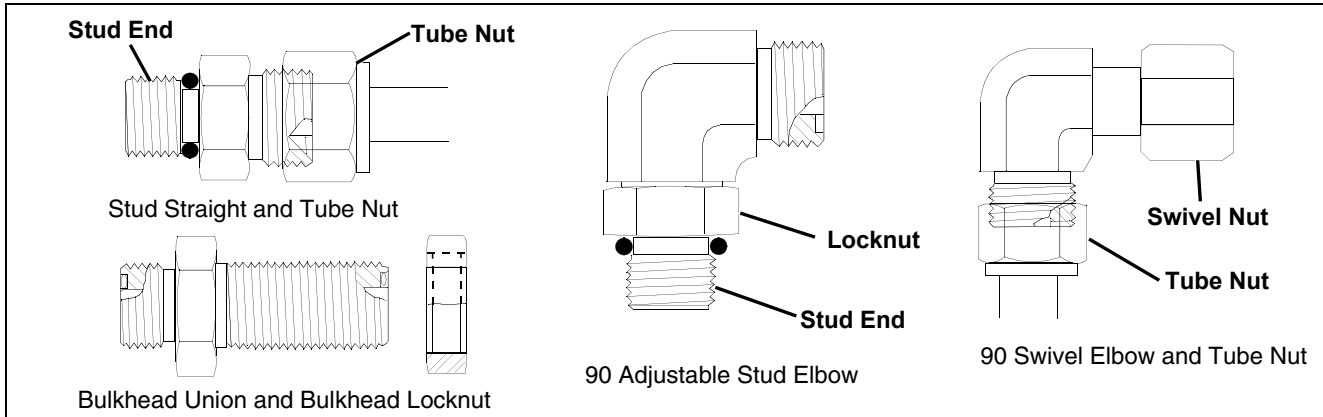

MIF

Nominal Tube OD/Hose ID				Face Seal Tube/Hose End					O-Ring Stud Ends		
Metric Tube OD	Inch Tube OD			Thread Size	Tube Nut/ Swivel Nut Torque		Bulkhead Lock Nut Torque		Thread Size	Straight Fitting or Lock Nut Torque	
	mm	Dash Size	in.		mm	in.	N•m	lb-ft		N•m	lb-ft
5	-3	0.188	4.76						3/8-24	8	6
6	-4	0.250	6.35	9/16-18	16	12	12	9	7/16-20	12	9
8	-5	0.312	7.94						1/2-20	16	12
10	-6	0.375	9.52	11/16-16	24	18	24	18	9/16-18	24	18
12	-8	0.500	12.70	13/16-16	50	37	46	34	3/4-16	46	34
16	-10	0.625	15.88	1-14	69	51	62	46	7/8-14	62	46
19	-12	0.750	19.05	1-3/16-12	102	75	102	75	1-1/16-12	102	75
22	-14	0.875	22.22	1-3/16-12	102	75	102	75	1-3/16-12	122	90
25	-16	1.000	25.40	1-7/16-12	142	105	142	105	1-5/16-12	142	105
32	-20	1.25	31.75	1-11/16-12	190	140	190	140	1-5/8-12	190	140
38	-24	1.50	38.10	2-12	217	160	217	160	1-7/8-12	217	160

NOTE: Torque tolerance is +15%, -20%

SPECIFICATIONS AND INFORMATION O-RING SEAL SERVICE

Face Seal Fittings With Metric Stud Ends Torque

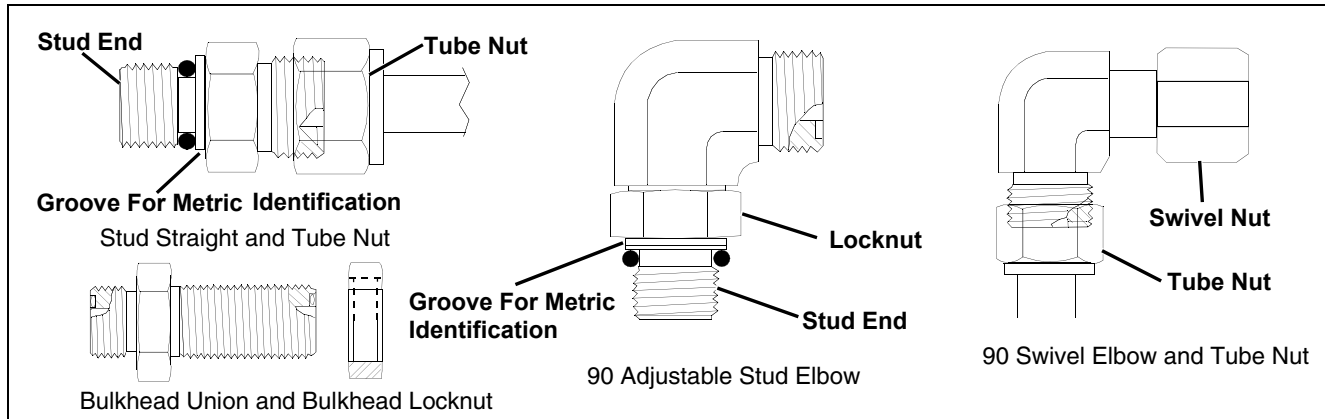

Nominal Tube OD/Hose ID				Face Seal Tube/Hose End						O-Ring Stud Ends, Straight Fitting or Lock Nut					
Metric Tube OD	Inch Tube OD			Thread Size	Hex Size	Tube Nut/ Swivel Nut Torque		Bulkhead Lock Nut Torque		Thread Size	Hex Size	Steel or Gray Iron Torque		Aluminum Torque	
	Dash Size	in.	mm			in.	mm	N•m	lb-ft			N•m	lb-ft	mm	mm
6	-4	0.250	6.35	9/16-18	17	16	12	12	9	M12X1.5	17	21	15.5	9	6.6
8	-5	0.312	7.94												
										M14X1.5	19	33	24	15	11
10	-6	0.375	9.52	11/16-16	22	24	18	24	18	M16X1.5	22	41	30	18	13
12	-8	0.500	12.70	13/16-16	24	50	37	46	34	M18X1.5	24	50	37	21	15
16	-10	0.625	15.88	1-14	30	69	51	62	46	M22X1.5	27	69	51	28	21
	-12	0.750	19.05	1-3/16-12	36	102	75	102	75	M27X2	32	102	75	46	34
22	-14	0.875	22.22	1-3/16-12	36	102	75	102	75	M30X2	36				
25	-16	1.000	25.40	1-7/16-12	41	142	105	142	105	M33X2	41	158	116	71	52
28										M38X2	46	176	130	79	58
32	-20	1.25	31.75	1-11/16-12	50	190	140	190	140	M42X2	50	190	140	85	63
38	-24	1.50	38.10	2-12	60	217	160	217	160	M48X2	55	217	160	98	72

NOTE: Torque tolerance is +15%, -20%

SPECIFICATIONS AND INFORMATION O-RING SEAL SERVICE

O-Ring Face Seal Fittings

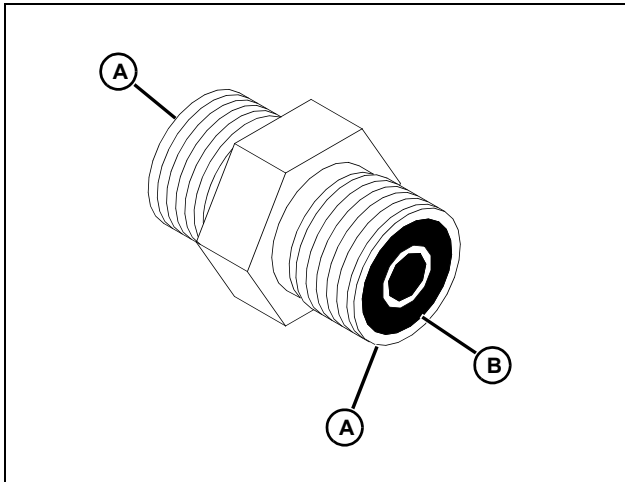

1. Inspect the fitting sealing surfaces (A). They must be free of dirt or defects.
2. Inspect the O-ring (B). It must be free of damage or defects.
3. Lubricate O-rings and install into groove using petroleum jelly to hold in place during assembly.
4. Index angle fittings and tighten by hand pressing joint together to insure O-ring remains in place.

IMPORTANT: Avoid damage! DO NOT allow hoses to twist when tightening fittings. Use two wrenches to tighten hose connections; one to hold the hose, and the other to tighten the swivel fitting.

5. Tighten fitting or nut to torque value shown on the chart per dash size stamped on the fitting.

O-Ring Boss Fittings

1. Inspect boss O-ring boss seat. It must be free of dirt and defects. If repeated leaks occur, inspect for defects with a magnifying glass. Some raised defects can be removed with a slip stone.

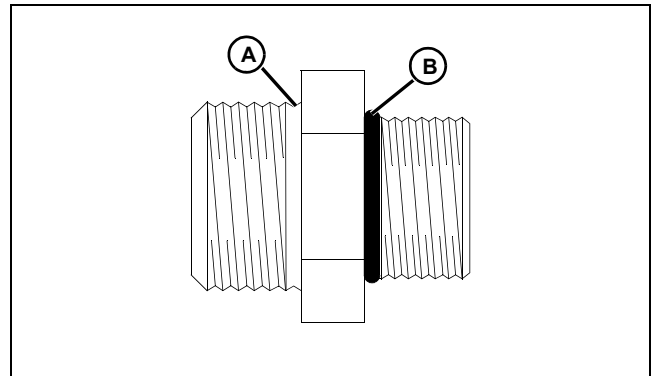

2. Put hydraulic oil or petroleum jelly on the O-ring (B). Place electrical tape over the threads to protect O-ring from nicks. Slide O-ring over the tape and into the groove (A) of fitting. Remove tape.

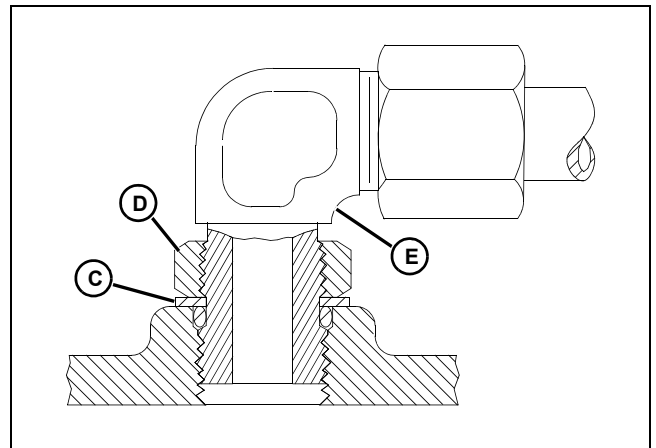

3. For angle fittings, loosen special nut (D) and push special washer (C) against threads so O-ring can be installed into the groove of fitting.
4. Turn fitting into the boss by hand until special washer or washer face (straight fitting) contacts boss face and O-ring is squeezed into its seat.
5. To position angle fittings (E), turn the fitting counter-clockwise a maximum of one turn.
6. Tighten straight fittings to torque value shown on chart. For angle fittings, tighten the special nut to value shown in the chart while holding body of fitting with a wrench.

SPECIFICATIONS AND INFORMATION GENERAL INFORMATION

Straight Fitting Or Special Nut Torques

Thread Size	Torque ^a		Number of Flats ^b
	N•m	lb-ft	
3/8-24 UNF	8	6	2
7/16-20 UNF	12	9	2
1/2-20 UNF	16	12	2
9/16-18 UNF	24	18	2
3/4-16 UNF	46	34	2
7/8-14 UNF	62	46	1-1/2
1-1/16-12 UN	102	75	1
1-3/16-12 UN	122	90	1
1-5/16-12 UN	142	105	3/4
1-5/8-12 UN	190	140	3/4
1-7/8-12 UN	217	160	1/2

^aTorque tolerance is \pm 10 percent.

^bTo be used if a torque wrench cannot be used. After tightening fitting by hand, put a mark on nut or boss; then tighten special nut or straight fitting the number of flats shown.

Metric Fastener Torque Value - Grade 7 (Special)

Size	Steel or Gray Iron Torque	Aluminum Torque
	N•m (lb-ft)	N•m (lb-ft)
M6	11 (8)	8 (6)
M8	24 (18)	19 (14)
M10	52 (38)	41 (30)
M12	88 (65)	70 (52)
M14	138 (102)	111 (82)
M16	224 (165)	179 (132)

General Information

Gasoline

4 - Cycle Engines



CAUTION: Avoid Injury! Gasoline is **HIGHLY FLAMMABLE**, handle it with care. **DO NOT** refuel machine while: indoors, always fill gas tank outdoors; machine is near an open flame or sparks; engine is running, **STOP** engine; engine is hot, allow it to cool sufficiently first; smoking. Help prevent fires: fill gas tank to bottom of filler neck only; be sure fill cap is tight after fueling; clean up any gas spills **IMMEDIATELY**; keep machine clean and in good repair - free of excess grease, oil, debris, and faulty or damaged parts; any storage of machines with gas left in tank should be in an area that is well ventilated to prevent possible igniting of fumes by an open flame or spark, this includes any appliance with a pilot light. To prevent fire or explosion caused by **STATIC ELECTRIC DISCHARGE** during fueling: **ONLY** use a clean, approved **POLYETHYLENE PLASTIC** fuel container and funnel **WITHOUT** any metal screen or filter.

To avoid engine damage:

- DO NOT mix oil with gasoline;
- **ONLY** use clean, fresh unleaded gasoline with an octane rating (anti-knock index) of 87 or higher;
- fill gas tank at the end of each day's operation to help prevent condensation from forming inside a partially filled tank;
- keep up with specified service intervals.

Use of alternative oxygenated, gasohol blended, unleaded gasoline is acceptable as long as:

- the ethyl or grain alcohol blends DO NOT exceed 10% by volume or
- methyl tertiary butyl ether (MTBE) blends DO NOT exceed 15% by volume

RFG (reformulated) gasoline is acceptable for all machines designed for use of regular unleaded fuel. Older machines (that were designed for leaded fuel) may see some accelerated valve and seat wear.

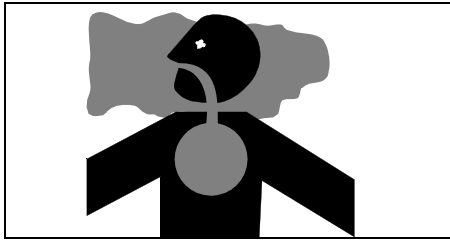

MIF

IMPORTANT: Avoid damage! California Proposition 65 Warning: Gasoline engine exhaust from this product contains chemicals known to the State of California to cause cancer, birth defects, or other reproductive harm.

Gasoline Storage

IMPORTANT: Avoid damage! Keep all dirt, scale, water or other foreign material out of gasoline.

Keep gasoline stored in a safe, protected area. Storage of gasoline in a clean, properly marked ("UNLEADED GASOLINE") POLYETHYLENE PLASTIC container WITHOUT any metal screen or filter is recommended. DO NOT use de-icers to attempt to remove water from gasoline or depend on fuel filters to remove water from gasoline. Use a water separator installed in the storage tank outlet. BE SURE to properly discard unstable or contaminated gasoline. When storing the machine or gasoline, it is recommended that you add **John Deere Gasoline Conditioner and Stabilizer (TY15977)** or an equivalent to the gasoline. BE SURE to follow directions on container and to properly discard empty container.

4 - Cycle Gasoline Engine Oil

Use the appropriate oil viscosity based on the expected air temperature range during the period between recommended oil changes. Operating outside of these recommended oil air temperature ranges may cause premature engine failure.

The following John Deere oils are PREFERRED:

- **PLUS - 4® - SAE 10W-40;**
- **TORQ - GARD SUPREME® - SAE 5W-30.**

The following John Deere oils are **also recommended**, based on their specified temperature range:

- **TURF - GARD® - SAE 10W-30;**
- **PLUS - 4® - SAE 10W-30;**
- **TORQ - GARD SUPREME® - SAE 30.**

Other oils may be used if above John Deere oils are not available, provided they meet one of the following specifications:

- SAE 10W-40 - API Service Classifications SG or higher;
- SAE 5W-30 - API Service Classification SG or higher;
- SAE 10W-30 - API Service Classifications SG or higher;
- SAE 30 - API Service Classification SC or higher.

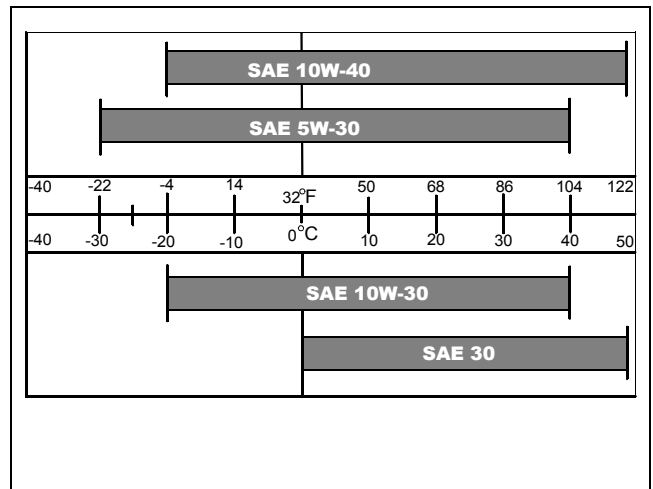

SPECIFICATIONS AND INFORMATION GENERAL INFORMATION

Break-In Engine Oil - 4-Cycle Gasoline

IMPORTANT: Avoid damage! ONLY use a quality break-in oil in rebuilt or remanufactured engines for the first 5 hours (maximum) of operation. DO NOT use oils with heavier viscosity weights than SAE 5W-30 or oils meeting specifications API SG or SH, these oils will not allow rebuilt or remanufactured engines to break-in properly.

The following John Deere oil is PREFERRED:

- **BREAK - IN ENGINE OIL.**

John Deere BREAK - IN ENGINE OIL is formulated with special additives for aluminum and cast iron type engines to allow the power cylinder components (pistons, rings, and liners as well) to “wear-in” while protecting other engine components, valve train and gears, from abnormal wear. Engine rebuild instructions should be followed closely to determine if special requirements are necessary.

John Deere BREAK - IN ENGINE OIL is also recommended for non-John Deere engines, both aluminum and cast iron types.

The following John Deere oil is **also recommended**:

- **TORQ - GARD SUPREME® - SAE 5W-30.**

If the above recommended John Deere oils are not available, use a break-in engine oil meeting the following specification during the first **5 hours (maximum)** of operation:

- SAE 5W-30 - API Service Classification SE or higher.

IMPORTANT: Avoid damage! After the break-in period, use the John Deere oil that is recommended for this engine.

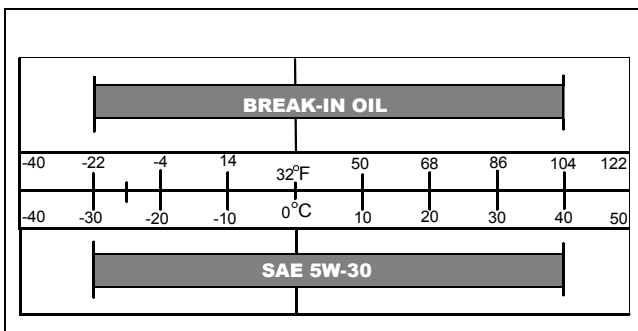

Grease

IMPORTANT: Avoid damage! Use recommended John Deere greases to avoid component failure and premature wear.

The recommended John Deere greases are effective within an average air temperature range of -29 to 135 degrees C (-20 to 275 degrees F).

If operating outside that temperature range, contact your Servicing dealer for a special-use grease.

The following greases are preferred:

- John Deere Multi-Purpose HD Lithium Complex Grease
- John Deere Multi-Purpose SD Polyurea Grease

If not using any of the preferred greases, be sure to use a general all-purpose grease with an NLGI grade No.2 rating.

Wet or high speed conditions may require use of a special-use grease. Contact your Servicing dealer for information.

Chain Lubricant

Use John Deere molybdenum disulfide (Moly) Chain & Cable Lubricant or an equivalent oil meeting John Deere specifications to lubricate drive chains. In dry dusty conditions, use of a dry lube is recommended.

Transaxle Oil

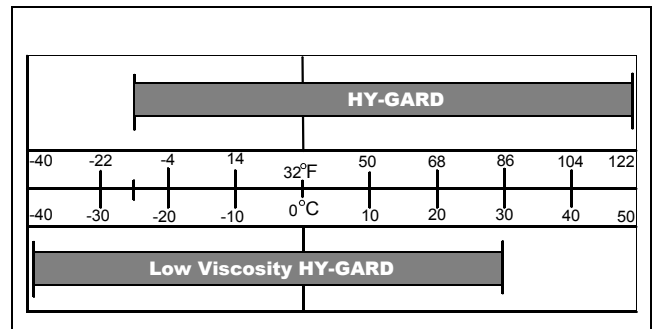

Use oil viscosity based on the expected air temperature range during the period between oil changes.

John Deere HY-GARD™ transmission and hydraulic oil is recommended for most normal operating temperatures.

NOTE: For temperatures below -13° C (0° F) John Deere low viscosity HY-GARD™ may be used. If used at temperatures above -13° C (0° F) some brake squeal may be heard due to lower viscosity of the oil at higher temperatures.

Other oils may be used if they meet John Deere standards JDM J20C and JDM J20D.

Alternative Lubricants

Use of alternative lubricants could cause reduced life of the component.

If alternative lubricants are to be used, it is recommended that the factory fill be thoroughly removed before switching to any alternative lubricant.

Synthetic Lubricants

Synthetic lubricants may be used in John Deere equipment if they meet the applicable performance requirements (industry classification and/or military specification) as shown in this manual.

The recommended air temperature limits and service or lubricant change intervals should be maintained as shown in the operator's manual, unless otherwise stated on lubricant label.

Avoid mixing different brands, grades, or types of oil. Oil manufacturers blend additives in their oils to meet certain specifications and performance requirements. Mixing different oils can interfere with the proper functioning of these additives and degrade lubricant performance.

Lubricant Storage

All machines operate at top efficiency only when clean lubricants are used. Use clean storage containers to handle all lubricants. Store them in an area protected from dust, moisture, and other contamination. Store drums on their sides. Make sure all containers are properly marked as to their contents. Dispose of all old, used containers and their contents properly.

Mixing of Lubricants

In general, avoid mixing different brands or types of lubricants. Manufacturers blend additives in their lubricants to meet certain specifications and performance requirements. Mixing different lubricants can interfere with the proper functioning of these additives and lubricant properties which will downgrade their intended specified performance.

Oil Filters

IMPORTANT: Avoid damage! Filtration of oils is critical to proper lubrication performance. Always change filters regularly.

The following John Deere oil filters are PREFERRED:

- AUTOMOTIVE AND LIGHT TRUCK ENGINE OIL FILTERS.

Most John Deere filters contain pressure relief and anti-drainback valves for better engine protection.

Other oil filters may be used if above recommended John Deere oil filters are not available, provided they meet the following specification:

- ASTB Tested In Accordance With SAE J806.

SPECIFICATIONS AND INFORMATION SERIAL NUMBER LOCATIONS

Serial Number Locations

Product Serial Number

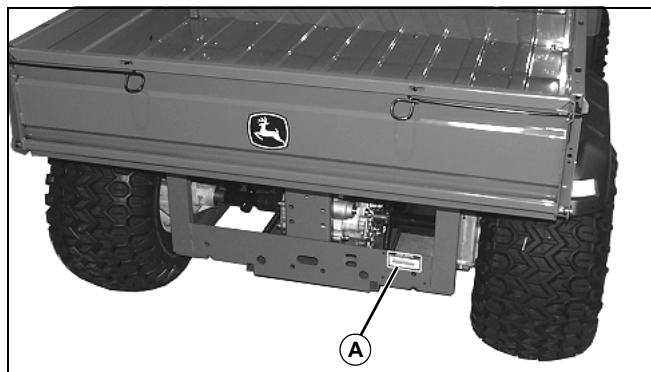

MX32931

The product identification number (A) is located on the rear of the frame.

Transaxle Serial Number Location

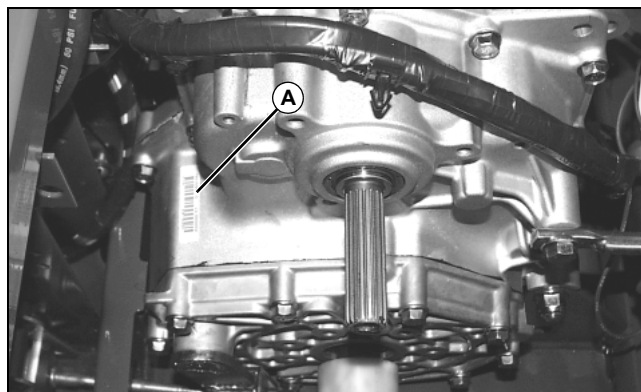

MX33823

TH model shown, driven clutch removed for clarity.

The transaxle identification number (A) is located on the top of the transaxle.

Engine Serial Number Location

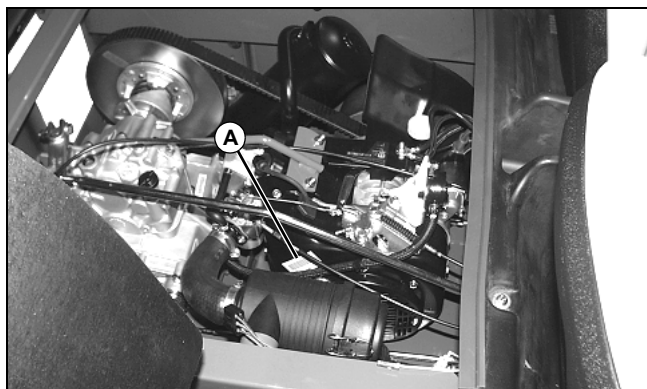

MX33443

4X2 TS engine serial number (A) can be located on the side of blower housing.



MX34206

6X4 TH engine serial number (A) can be located on the side of the blower housing.

ENGINE - GAS FE290D TABLE OF CONTENTS

Table of Contents

Specifications21

General Specifications	21
Test and Adjustment Specifications	21
Repair Specifications.....	22
Carburetor Jets.....	25
Special or Essential Tools	25
Other Materials.....	25

Component Location.....26

FE290D Engine	26
Fuel System Components	27
Carburetor Components.....	28
Balancer Components.....	29
Starting Motor Components	30

Diagnostics31

Engine Troubleshooting Guide.....	31
Starting Motor Troubleshooting Guide	32

Tests and Adjustments33

Throttle Cable and Pedal Stop Adjustment ..	33
Choke Cable Adjustment.....	34
Air Intake System Check	34
Governor Adjustment	35
Slow Idle Mixture Screw and Speed Adjust- ments.....	36
Fast Idle Speed Adjustment	37
Fuel Pump Pressure Test.....	37
Fuel Pump Flow Test	38
Cylinder Compression Test.....	38
Valve Clearance Adjustment.....	39
Automatic Compression Release (ACR) Test	40
Crankcase Vacuum Test.....	41
Ignition Coil Air Gap Adjustment	41
Spark Test.....	42
Oil Pressure Test.....	42

Repair.....43

Muffler Removal and Installation	43
Fuel Pump Removal and Installation.....	44
Carburetor Removal and Installation.....	44
Carburetor Disassembly and Assembly	45
Engine Removal and Installation.....	47
Crankcase Breather Inspection	48
Blower Housing Removal and Installation....	49
Flywheel Removal and Installation.....	49
Rocker Arm Removal and Installation	49

Rocker Arm Inspection	50
Cylinder Head Removal and Installation.....	50
Cylinder Head Disassembly and Assembly .	51
Cylinder Head Inspection and Replacement	51
Recondition Valve Seats.....	53
Lap Valves.....	54
Crankcase Cover Removal and Installation.	54
Camshaft Removal and Installation.....	55
Camshaft Inspection	55
Automatic Compression Release	56
Tappets Inspection and Replacement	56
Piston and Connecting Rod.....	56
Reciprocating Balancer.....	59
Crankshaft Removal and Installation	60
Crankshaft Inspection.....	60
Crankshaft End Play Check.....	61
Analyze Crankshaft and Connecting Rod Wear	61
Crankshaft End Play Adjustment.....	62
Crankshaft Oil Seal - Flywheel End Replacement.....	62
Crankshaft Oil Seal - PTO End Replacement.....	62
Cylinder Block Inspection	63
Cylinder Deglazing.....	63
Cylinder Boring.....	63
Oil Pump Disassembly and Assembly	64
Oil Pump Inspection.....	65
Governor Inspection and Replacement	66
Governor Shaft Inspection and Replacement.....	66
Governor Shaft Oil Seal Replacement.....	66
Ignition Module Removal and Installation	66
Stator Removal and Installation.....	67

ENGINE - GAS FE290D TABLE OF CONTENTS



ENGINE - GAS FE290D SPECIFICATIONS

Specifications

General Specifications

Engine Use	TS
Make	Kawasaki
Model	FE290D
Type	4-cycle gas/Air cooled
Power	7.46 kW (10 hp)
Cylinders	1
Cycles	4
Bore	78 mm (3.070 in.)
Stroke	60 mm (2.360 in.)
Displacement	286 cm ³ (17.5 cu-in.)
Crankcase Oil Capacity	0.9 L (0.95 qt)
Crankcase Oil Capacity (With Filter)	1.2 L (1.25 qt)
Spark Plug	NGK BPR5ES
Compression Release	Automatic
Crankshaft Type	Horizontal, Counterbalanced
Lubrication	Pressurized, Positive Displacement Pump
Oil Pressure	314 kPa (46 psi)
Oil Filter	Full Flow, Spin-On Filter
Cooling System	Air Cooled
Air Cleaner	Single Element, Replaceable Paper
Muffler	45° Angled Down, Optional Spark Arrestor
Governed Slow Idle	1125 ± 75 rpm
Fast Idle	3850 ± 50 rpm
Maximum Angle of Operation (Full Crankcase): Continuous (All Directions)	25°
Intermittent (3 Minutes or Less All Directions)	30°
Fuel Filter	Replaceable, In-Line Type
Fuel Pump	Engine Mounted Diaphragm-type Pulse Pump
Carburetor	Float type, Fixed Main Jet
Charging System	12 Volt, 3 - 13 Amps with Regulator

Test and Adjustment Specifications

Engine:

Spark Plug Gap	0.8 mm (0.031 in.)
Intake and exhaust valve clearance (cold)	0.127 ± 0.025 mm (0.005 ± 0.001 in.)
Intake and exhaust valve adjustment interval	300 hrs
Oil pressure at high idle (minimum)	314 kPa (46 psi)
Oil filter bypass valve opening pressure	78 - 118 kPa (11.3 - 17.0 psi)
Compression pressure at operating temperature (minimum)	393 kPa (57 psi)
Compression pressure at operating temperature (maximum)	965 kPa (140 psi)

ENGINE - GAS FE290D SPECIFICATIONS

Crankcase vacuum (minimum)	25 mm (1 in.) water movement
Valve clearance adjusting nut torque	10 N•m (90 lb-in.)
Auto Compression Release minimum lift	0.6 mm (0.023 in.)
Auto Compression Release standard lift	1.2 mm (0.047 in.)
Auto Compression Release release rpm600 ± 100 rpm
Breather reed valve tip air gap	0.2 mm (0.008 in.)
Valve cover cap screw torque	6 N•m (53 lb-in.)
Fuel/Air System:	
Fuel Pump Minimum Pressure	6.12 kPa (0.9 psi)
Fuel Pump Minimum Flow	80 ml (2.7 oz) in 15 seconds
Governed Slow idle setting1125 ± 75 rpm
Carburetor Butterfly Slow idle stop screw setting200 rpm less than Governed Slow idle setting
Throttle control arm FAST idle stop screw setting3850 ± 50 rpm

Repair Specifications

Miscellaneous Repair Specifications

Breather Maximum Air Gap	0.20 mm (0.008 in.)
Flywheel Nut Torque	85 N•m (63 lb-ft)

Cylinder Head Assembly

Cylinder Head Flatness	0.05 mm (0.002 in.)
Cap Screw Torque	
First	18 N•m (159 lb-in.)
Second	21 N•m (186 lb-in.)
Final	24 N•m (212 lb-in.)
Spark Plug Torque	27 N•m (239 lb-in.)

Rocker Arm:

Minimum Shaft OD	11.95 mm (0.470 in.)
Maximum Bearing ID	12.07 mm (0.475 in.)

Push Rod:

Maximum Bend	0.3 mm (0.012 in.)
------------------------	--------------------

Valves and Springs:

Valve Clearance	0.127 mm (0.005 in.)
Valve Seat Width	0.50 - 1.10 mm (0.020 - 0.043 in.)
Maximum Valve Seat Width	1.9 mm (0.075 in.)

Intake and Exhaust Valves

Maximum Bend	0.03 mm (0.0012 in.)
Maximum Valve Face Margin	0.060 mm (0.024 in.)
Valve Stem OD (Wear Limit)	
Intake Valve	6.930 mm (0.2728 in.)
Exhaust Valve	6.915 mm (0.2722 in.)

ENGINE - GAS FE290D SPECIFICATIONS

Valve Guides

Maximum Guide ID	7.065 mm (0.2781 in.)
Finished (Reamed) ID	7.00 - 7.015 mm (0.2756 - 0.2762 in.)
Valve Springs Minimum Free Length	32.75 mm (1.289 in.)
Valve Seat - Recondition	
Valve Face Angle	45°
Valve Narrowing Angle	30°
Valve Seat Angle	45°
Valve Seating Surface Width	0.50 - 1.10 mm (0.020 - 0.043 in.)

Crankcase:

Cover Mounting Cap Screw Torque	26 N•m (230 lb-in.)
Oil Drain Plug Torque	20 N•m (180 lb-in.)
Maximum Crankcase Main Bearing ID	30.08 mm (1.184 in.)
End Play	0.09 - 0.22 mm (0.004 - 0.009 in.)
Crankshaft Oil Seal Depth (PTO End)	4 mm (0.158 in.)
Governor Mounting Shaft Height (Top of Shaft-to-Cover)	32.2 - 32.8 mm (1.267 - 1.291 in.)
Governor Shaft Oil Seal Depth	1.42 mm (0.056 in.)

Camshaft:

Minimum Cam Lobe Height	32.70 mm (1.287 in.)
Minimum PTO and Flywheel Side Journal OD	22.93 mm (0.903 in.)
Maximum Cylinder Block and Cover Bearing ID	23.06 mm (0.908 in.)

Crankshaft:

Maximum Total Indicated Runout	0.05 mm (0.002 in.)
Minimum Main Bearing Journal OD	29.92 mm (1.178 in.)
Minimum Connecting Rod Journal OD	
Standard	35.43 mm (1.395 in.)
Undersized	34.93 mm (1.375 in.)
Crankshaft Bearing	
Standard	35.57 mm (1.400 in.)
Undersized	35.07 mm (1.380 in.)

Reciprocating Balancer:

Link Rod

Minimum Journal OD	46.86 mm (1.845 in.)
Maximum Small End ID	12.06 mm (0.475 in.)
Maximum Large End ID	47.12 mm (1.855 in.)
Bushing Depth	1.00 mm (0.040 in.)

Support Shaft

Maximum Bearing ID	26.10 mm (1.027 in.)
Minimum Shaft OD	25.93 mm (1.021 in.)

ENGINE - GAS FE290D SPECIFICATIONS

Piston and Rings:

Maximum Ring Groove Clearance

First Compression Ring 0.16 mm (0.006 in.)

Second Compression Ring 14 mm (0.005 in.)

Oil Ring AssemblyNot Measured

Maximum Ring End Gap

Compression Rings 120 mm (0.047 in.)

Oil Ring AssemblyNot Measured

Maximum Piston Pin Bore ID 19.03 mm (0.749 in.)

Minimum Piston Pin OD 18.98 mm (0.747 in.)

Piston OD, Standard 77.85 - 77.87 mm (3.0649 - 3.0657 in.)

Piston OD, Oversized (0.50 mm (0.020 in.)) 78.35 - 78.37 mm (3.0849 - 3.0857 in.)

Connecting Rod:

Maximum Crankshaft Bearing ID

Standard 35.57 mm (1.400 in.)

Undersized 35.07 mm (1.380 in.)

Maximum Piston Pin Bearing ID 19.06 mm (0.750 in.)

End-Cap Screw Torque 20 N•m (177 lb-in.)

Cylinder Bore ID:

Standard Size Bore

Standard 77.98 - 78.00 mm (3.070 - 3.071 in.)

Wear Limit 78.07 mm (3.074 in.)

Out-of-Round (Maximum) 0.056 mm (0.0022 in.)

0.50 mm (0.020 in.) Oversize Bore

Standard 78.46 - 78.48 mm (3.089 - 3.090 in.)

Wear Limit 78.55 mm (3.093 in.)

Oil Pump

Maximum Outer Rotor Bearing Depth 10.17 mm (0.400 in.)

Maximum Outer Rotor Shaft Bearing ID 40.77 mm (1.605 in.)

Minimum Outer Rotor Shaft OD 40.47 mm (1.596 in.)

Minimum Outer Rotor Thickness 9.92 mm (0.391 in.)

Minimum Relief Valve Spring Free Length 19 mm (0.748 in.)

Maximum Rotor Shaft Bearing ID 12.77 mm (0.503 in.)

Minimum Rotor Shaft OD 12.63 mm (0.497 in.)

ENGINE - GAS FE290D SPECIFICATIONS

Carburetor Jets

Jet	Part No.	Part Use
Pilot Air Jet #40	M19186	Used for all altitudes
Main Jet #90	UP04795	0 to 1000 m (0 to 3279 ft)
Main Jet #88	M140510	1000 to 2000 m (3279 to 6557 ft)
Main Jet #85	M128974	2000 m and above (6557 ft and above)

Special or Essential Tools

NOTE: Order tools according to information given in the U.S. SERVICE-GARD™ Catalog or in the European Microfiche Tool Catalog (MTC).

Special or Required Tools

Tool Name	Tool No.	Tool Use
Digital Tachometer	JT05719	Slow idle mixture screw and speed adjustments, and fast idle speed adjustment.
Fuel Pump Pressure Test Kit	JDG356	Fuel pump pressure test.
Carburetor Test Kit	JDZ25-2	Fuel tank check valve test.
Compression Gauge Spark Plug Test Tool	JDM59 JDM-74A-5	Cylinder compression test, and Valve clearance adjustment.
Dial Indicator		Automatic compression relief test, valve inspection, crankshaft end play
Pressure Gauge Assembly Hose Assembly Connector 1/8" BSP Thread	JT05577 JT03017 JT03349	Oil pressure test. (If oil filter option is installed)
Valve Spring Compressor	JDM70	Cylinder head disassembly and assembly.
Valve Guide Driver Tool	JDG504	Replace valve guides.

Other Materials

Other Material

Part No.	Part Name	Part Use
M79292	MPG-2® Multipurpose Grease	Apply to engine crankshaft
PT569	John Deere NEVER-SEEZ® Lubricant	Apply to crankshaft end
	SCOTCH-BRIGHT® Abrasive Sheets/Pads	Clean cylinder head.
	Valve Guide Cleaner	Clean valve guides.
	Stanisol or Kerosene	Finish ream valve guide.
	Prussian Blue Compound	Check valve seat contact.
	Lithium Base Grease	Pack oil seals.
	Zinc Oxide/Wood Alcohol	Check block for cracks.
	Mineral Spirits	Clean electric starter armature.

ENGINE - GAS FE290D COMPONENT LOCATION

Product: John Deere TS and TH 6x4 Gator Utility Vehicle Service Repair Technical Manual

Full Download: <https://www.bobmanualstore.com/downloads/john-deere-ts-and-th-6x4-gator-utility-vehicle-service-repair-technical-manual/>

FE290D Engine

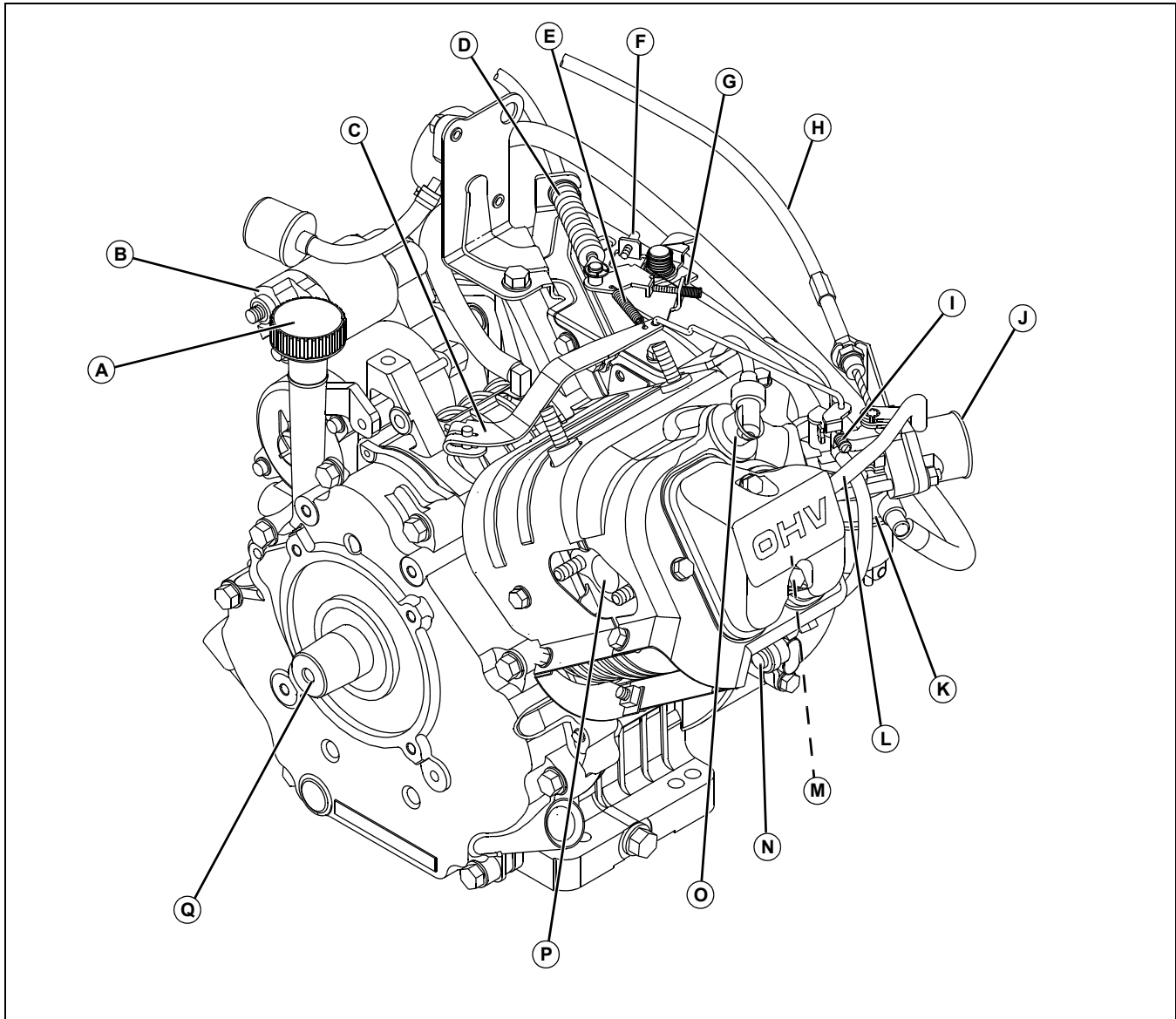

- A - Engine Oil Dipstick
- B - Starting Motor Solenoid
- C - Governor Arm Assembly
- D - Throttle Cable Assembly
- E - Governor Spring
- F - Fast Idle Screw
- G - Slow Idle Governor Screw
- H - Choke Cable Assembly
- I - Carburetor Butterfly Stop Screw
- J - Carburetor Air Intake
- K - Carburetor Assembly
- L - Crankcase Vent Hose

- M - Intake and Exhaust Valves
- N - Oil Pressure Test Port
- O - Spark Plug
- P - Exhaust Port
- Q - Crankshaft

Sample manual. Download All 384 pages at:

<https://www.bobmanualstore.com/downloads/john-deere-ts-and-th-6x4-gator-utility-vehicle-service-repair-technical-manual/>