

Product: John Deere Aercore Aerator 800, 1000, 1500, and 2000 Service Repair Technical Manual
Full Download: <https://www.bobmanualstore.com/downloads/john-deere-aercore-aerator-800-1000-1500-and-2000-service-repair-technical-manual/>

JOHN DEERE
WORLDWIDE COMMERCIAL & CONSUMER
EQUIPMENT DIVISION

Aercore Aerator
800, 1000, 1500, and 2000

TM1631 DEC05

TECHNICAL MANUAL



JOHN DEERE

North American Version
Litho in U.S.A.

Sample manual. Download All 264 pages at:

<https://www.bobmanualstore.com/downloads/john-deere-aercore-aerator-800-1000-1500-and-2000-service-repair-technical-manual/>

Product: John Deere Aercore Aerator 800, 1000, 1500, and 2000 Service Repair Technical Manual
Full Download: <https://www.bobmanualstore.com/downloads/john-deere-aercore-aerator-800-1000-1500-and-2000-service-repair-technical-manual/>

Sample manual. Download All 264 pages at:
<https://www.bobmanualstore.com/downloads/john-deere-aercore-aerator-800-1000-1500-and-2000-service-repair-technical-manual/>

INTRODUCTION

Manual Description

This technical manual is written for an experienced technician and contains sections that are specifically for this product. It is a part of a total product support program.

The manual is organized so that all the information on a particular system is kept together. The order of grouping is as follows:

- Table of Contents
- Specifications and Information
- Identification Numbers
- Tools and Materials
- Component Location
- Schematics and Harnesses
- Theory of Operation
- Operation and Diagnostics
- Diagnostics
- Tests and Adjustments
- Repair
- Other

NOTE: Depending on the particular section or system being covered, not all of the above groups may be used.

The bleed tabs for the pages of each section will align with the sections listed on this page. Page numbering is consecutive from the beginning of the Safety section through the last section.

We appreciate your input on this manual. If you find any errors or want to comment on the layout of the manual please contact us.

Safety

Specifications and Information

Engine

Electrical

Power Train

Hydraulics

Miscellaneous

All information, illustrations and specifications in this manual are based on the latest information at the time of publication. The right is reserved to make changes at any time without notice.

COPYRIGHT© 2005
Deere & Co.
John Deere Worldwide Commercial and
Consumer Equipment Division
All rights reserved
Previous Editions
COPYRIGHT© 2003, 1997, 1996

INTRODUCTION

SAFETY

Recognize Safety Information



MIF

This is the safety-alert symbol. When you see this symbol on your machine or in this manual, be alert to the potential for personal injury.

Follow recommended precautions and safe servicing practices.

Understand Signal Words

A signal word - DANGER, WARNING, or CAUTION - is used with the safety - alert symbol. DANGER identifies the most serious hazards.

DANGER or WARNING safety signs are located near specific hazards. General precautions are listed on CAUTION safety signs. CAUTION also calls attention to safety messages in this manual.

Replace Safety Signs

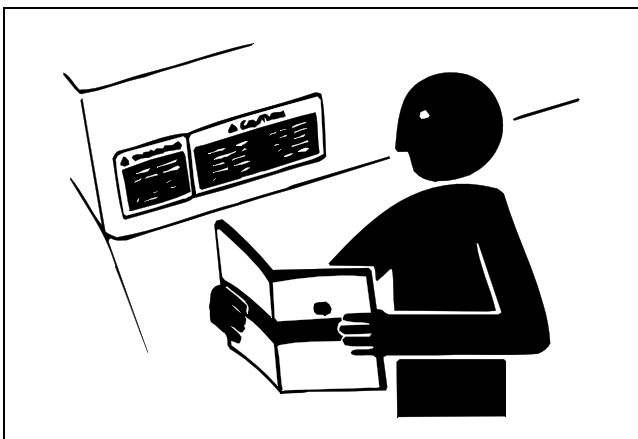

MIF

Replace missing or damaged safety signs. See the machine operator's manual for correct safety sign placement.

Handle Fluids Safely - Avoid Fires

Be Prepared For Emergencies

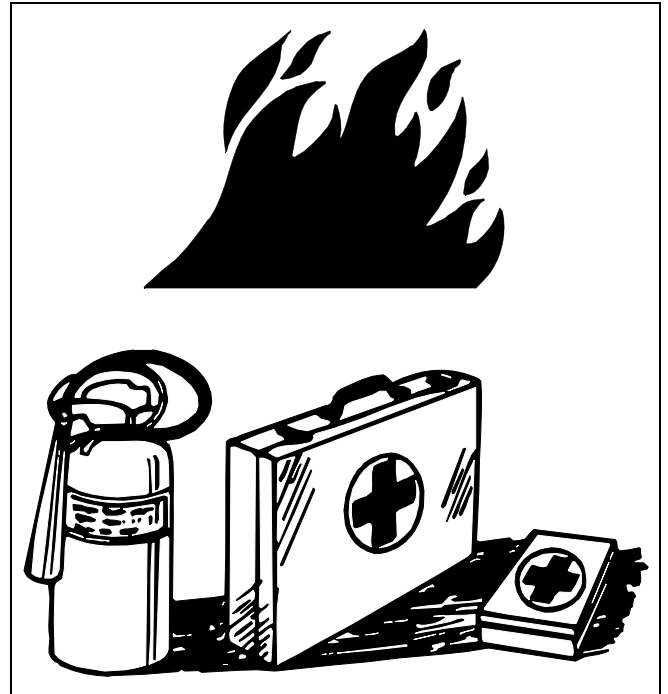

MIF

- When you work around fuel, do not smoke or work near heaters or other fire hazards.
- Store flammable fluids away from fire hazards. Do not incinerate or puncture pressurized containers.
- Make sure machine is clean of trash, grease, and debris.
- Do not store oily rags; they can ignite and burn spontaneously.
- Be prepared if a fire starts.
- Keep a first aid kit and fire extinguisher handy.
- Keep emergency numbers for doctors, ambulance service, hospital, and fire department near your telephone.

Use Care In Handling and Servicing Batteries

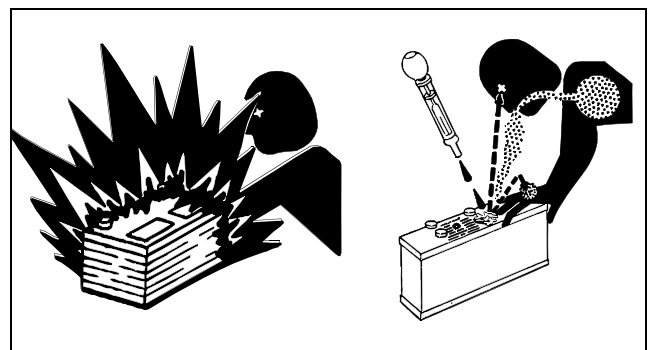

MIF

SAFETY

Prevent Battery Explosions

- Keep sparks, lighted matches, and open flame away from the top of battery. Battery gas can explode.
- Never check battery charge by placing a metal object across the posts. Use a volt-meter or hydrometer.
- Do not charge a frozen battery; it may explode. Warm battery to 16°C (60°F).

Prevent Acid Burns

- Sulfuric acid in battery electrolyte is poisonous. It is strong enough to burn skin, eat holes in clothing, and cause blindness if splashed into eyes.

Avoid acid burns by:

1. Filling batteries in a well-ventilated area.
2. Wearing eye protection and rubber gloves.
3. Avoiding breathing fumes when electrolyte is added.
4. Avoiding spilling or dripping electrolyte.
5. Use proper jump start procedure.

If you spill acid on yourself:

1. Flush your skin with water.
2. Apply baking soda or lime to help neutralize the acid.
3. Flush your eyes with water for 10 - 15 minutes.
4. Get medical attention immediately.

If acid is swallowed:

1. Drink large amounts of water or milk.
2. Then drink milk of magnesia, beaten eggs, or vegetable oil.
3. Get medical attention immediately.

Wear Protective Clothing

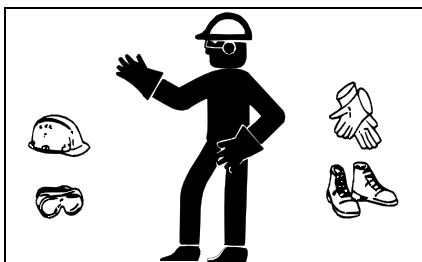

MIF

Wear close fitting clothing and safety equipment appropriate to the job.

Prolonged exposure to loud noise can cause impairment or loss of hearing. Wear a suitable hearing protective device such as earmuffs or earplugs to protect against

objectionable or uncomfortable loud noises.

Operating equipment safely requires the full attention of the operator. Do not wear radio or music headphones while operating machine.

Use Care Around High-pressure Fluid Lines

Avoid High-Pressure Fluids



MIF

Escaping fluid under pressure can penetrate the skin causing serious injury.

Avoid injury from escaping fluid under pressure by stopping the engine and relieving pressure in the system before disconnecting or connecting hydraulic or other lines. Tighten all connections before applying pressure.

Search for leaks with a piece of cardboard. Protect hands and body from high pressure fluids.

If an accident occurs, see a doctor immediately. Any fluid injected into the skin must be surgically removed within a few hours or gangrene may result. Doctors unfamiliar with this type of injury should reference a knowledgeable medical source. Such information is available from Deere & Company Medical Department in Moline, Illinois, U.S.A.

Avoid Heating Near Pressurized Fluid Lines



MIF

Flammable spray can be generated by heating near pressurized fluid lines, resulting in severe burns to yourself and bystanders. Do not heat by welding, soldering, or using a torch near pressurized fluid lines or other flammable materials. Pressurized lines can be accidentally cut when heat goes beyond the immediate flame area.

SAFETY

Service Machines Safely

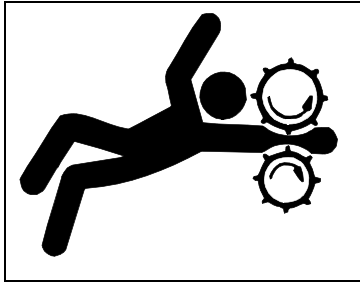

MIF

Tie long hair behind your head. Do not wear a necktie, scarf, loose clothing, or necklace when you work near machine tools or moving parts. If these items were to get caught, severe injury could result.

Remove rings and other jewelry to prevent electrical shorts and entanglement in moving parts.

Use Proper Tools

Use tools appropriate to the work. Makeshift tools and procedures can create safety hazards. Use power tools only to loosen threaded parts and fasteners. For loosening and tightening hardware, use the correct size tools. **DO NOT** use U.S. measurement tools on metric fasteners. Avoid bodily injury caused by slipping wrenches. Use only service parts meeting John Deere specifications.

Park Machine Safely

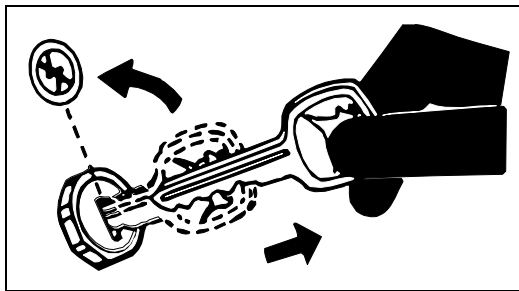

MIF

Before working on the machine:

1. Lower all equipment to the ground.
2. Stop the engine and remove the key.
3. Disconnect the battery ground strap.
4. Hang a "DO NOT OPERATE" tag in operator station.

Support Machine Properly and Use Proper Lifting Equipment

MIF

If you must work on a lifted machine or attachment,

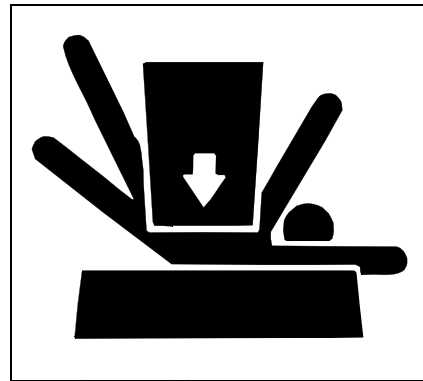

securely support the machine or attachment.

Do not support the machine on cinder blocks, hollow tiles, or props that may crumble under continuous load. Do not work under a machine that is supported solely by a jack. Follow recommended procedures in this manual.

Lifting heavy components incorrectly can cause severe injury or machine damage. Follow recommended procedure for removal and installation of components in the manual.

Work In Clean Area

Before starting a job:

1. Clean work area and machine.
2. Make sure you have all necessary tools to do your job.
3. Have the right parts on hand.
4. Read all instructions thoroughly; do not attempt shortcuts.

Using High Pressure Washers

Directing pressurized water at electronic/electrical components or connectors, bearings, hydraulic seals, fuel injection pumps or other sensitive parts and components may cause product malfunctions. Reduce pressure and spray at a 45 to 90 degree angle.

Illuminate Work Area Safely

Illuminate your work area adequately but safely. Use a portable safety light for working inside or under the machine. Make sure the bulb is enclosed by a wire cage. The hot filament of an accidentally broken bulb can ignite spilled fuel or oil.

SAFETY

Work In Ventilated Area

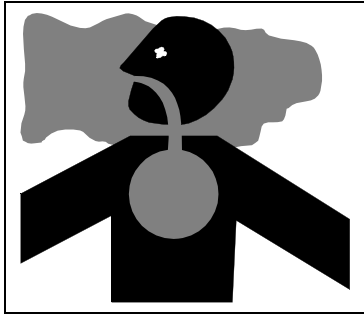

MIF

Engine exhaust fumes can cause sickness or death. If it is necessary to run an engine in an enclosed area, remove the exhaust fumes from the area with an exhaust pipe extension.

If you do not have an exhaust pipe extension, open the doors and get outside air into the area.

Warning: California Proposition 65 Warning

Gasoline engine exhaust from this product contains chemicals known to the State of California to cause cancer, birth defects, or other reproductive harm.

Diesel engine exhaust and some of its constituents are known to the State of California to cause cancer, birth defects, and other reproductive harm.

Remove Paint Before Welding or Heating

Avoid potentially toxic fumes and dust. Hazardous fumes can be generated when paint is heated by welding, soldering, or using a torch. Do all work outside or in a well ventilated area. Dispose of paint and solvent properly. Remove paint before welding or heating: If you sand or grind paint, avoid breathing the dust. Wear an approved respirator. If you use solvent or paint stripper, remove stripper with soap and water before welding. Remove solvent or paint stripper containers and other flammable material from area. Allow fumes to disperse at least 15 minutes before welding or heating.

Avoid Harmful Asbestos Dust

Avoid breathing dust that may be generated when handling components containing asbestos fibers. Inhaled asbestos fibers may cause lung cancer.

Components in products that may contain asbestos fibers are brake pads, brake band and lining assemblies, clutch plates, and some gaskets. The asbestos used in these components is usually found in a resin or sealed in some way. Normal handling is not hazardous as long as airborne dust containing asbestos is not generated.

Avoid creating dust. Never use compressed air for cleaning. Avoid brushing or grinding material containing asbestos. When servicing, wear an approved respirator. A special vacuum cleaner is recommended to clean asbestos. If not available, apply a mist of oil or water on the material containing asbestos. Keep bystanders away from the area.

Service Tires Safely



MIF

Explosive separation of a tire and rim parts can cause serious injury or death.

Do not attempt to mount a tire unless you have the proper equipment and experience to perform the job.

Always maintain the correct tire pressure. Do not inflate the tires above the recommended pressure. Never weld or heat a wheel and tire assembly. The heat can cause an increase in air pressure resulting in a tire explosion. Welding can structurally weaken or deform the wheel.

When inflating tires, use a clip-on chuck and extension hose long enough to allow you to stand to one side and NOT in front of or over the tire assembly. Use a safety cage if available.

Check wheels for low pressure, cuts, bubbles, damaged rims or missing lug bolts and nuts.

SAFETY

Avoid Injury From Rotating Blades, Augers, and PTO Shafts

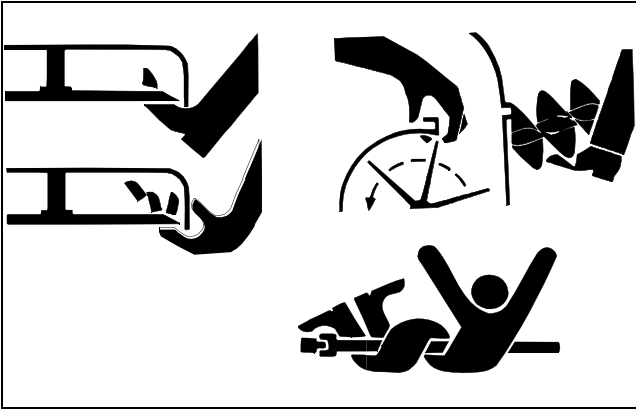

MIF

Keep hands and feet away while machine is running. Shut off power to service, lubricate or remove mower blades, augers or PTO shafts.

Service Cooling System Safely

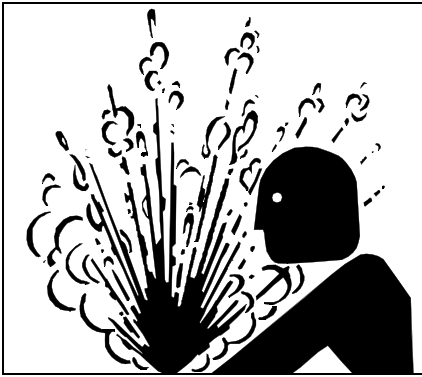

MIF

Explosive release of fluids from pressurized cooling system can cause serious burns.

Shut off machine. Only remove filler cap when cool enough to touch with bare hands. Slowly loosen cap to first stop to relieve pressure before removing completely.

Handle Chemical Products Safely

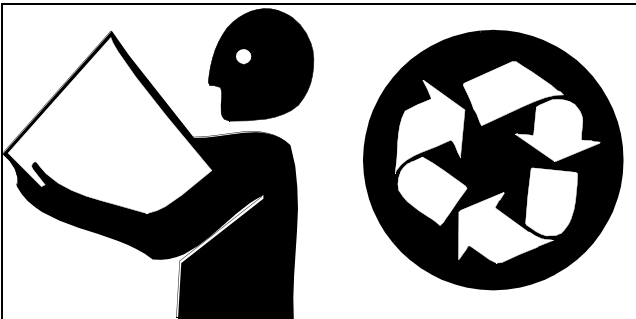

MIF

Direct exposure to hazardous chemicals can cause serious injury. Potentially hazardous chemicals used with John Deere equipment include such items as lubricants, coolants, paints, and adhesives.

A Material Safety Data Sheet (MSDS) provides specific details on chemical products: physical and health hazards, safety procedures, and emergency response techniques. Check the MSDS before you start any job using a hazardous chemical. That way you will know exactly what the risks are and how to do the job safely. Then follow procedures and recommended equipment.

Dispose Of Waste Properly

Improperly disposing of waste can threaten the environment and ecology. Potentially harmful waste used with John Deere equipment include such items as oil, fuel, coolant, brake fluid, filters, and batteries. Use leakproof containers when draining fluids. Do not use food or beverage containers that may mislead someone into drinking from them. Do not pour waste onto the ground, down a drain, or into any water source. Inquire on the proper way to recycle or dispose of waste from your local environmental or recycling center, or from your John Deere dealer.

Live With Safety



MIF

Before returning machine to customer, make sure machine is functioning properly, especially the safety systems. Install all guards and shields.

SAFETY



SPECIFICATIONS & INFORMATION TABLE OF CONTENTS

Table Of Contents

Specifications	9
Aercore 800	9
Aercore 1000	11
Aercore 1500	12
Aercore 2000	12
Fastener Torques.....	13
Metric Fastener Torque Values	13
Inch Fastener Torque Values	15
O-Ring Seal Service Recommendations	16
Face Seal Fittings With Inch Stud Ends Torque.....	16
Face Seal Fittings With Metric Stud Ends Torque.....	17
O-Ring Face Seal Fittings	18
O-Ring Boss Fittings	18
Straight Fitting or Special Nut Torques	19
Metric Fastener Torque Value - Grade 7 (Special)	19
General Information.....	19
Using Proper Fuel	19
4 - Cycle Gasoline Engine Oil	19
Gear Case Oil.....	20
Hydraulic Pump Oil.....	20
Transaxle Housing Grease.....	20
Gear Transmission Grease	20
Alternative Lubricants	21
Synthetic Lubricants	21
Lubricant Storage	21
Mixing of Lubricants	21
Oil Filters	21
Serial Number Locations	22
Product Serial Number (800).....	22
Product Serial Number (1000, 1500 and 2000)	22

SPECIFICATIONS & INFORMATION TABLE OF CONTENTS



SPECIFICATIONS & INFORMATION SPECIFICATIONS

Specifications

Aercore 800

Engine

Make	Kohler
Type	OHV, horizontal shaft, 4-cycle, V-twin
Engine Model Number	CH730S
Aspiration	Natural
Bore	83 mm (3.27 in.)
Stroke	67 mm (2.64 in.)
Displacement	725 cm ³ (44 cu in.)
Cylinders	2
Ignition	Electronic
High Idle Setting	3000 rpm
Low Idle Setting	1200 rpm
Compression Ratio	9.0:1
Lubrication	Full Pressure with Full Flow Filter
Cooling System	Air Cooled
Oil Capacity (with filter)	2.0 L (2.1 qt)
Hydraulic Pump Capacity	1.9 L (2.0 qt)
Air Cleaner	Dual-stage, dry, replaceable
Oil Filter	Replaceable, full flow

Electrical System

Battery Specifications

Voltage	12 VDC
BCI Group	45
CCA Ratings (Amps at -18°C (0°F))	480
Reserve Capacity (minutes at 25 Amps)	80
Specific Gravity (minimum)	1.265 points
Load Test (minimum)	480 amp for 5 seconds
John Deere Battery Group	B

Ignition

Capacitive Discharge Air Gap	0.28 - 0.33 mm (0.011 - 0.013 in.)
------------------------------------	------------------------------------

Spark Plug

Gap	0.76 mm (0.030 in.)
Torque	24.4 - 29.8 N•m (18 - 22 lb-ft)

Starting Motor

Type (SN -035000)	Nippondenso Solenoid Shift
Type (SN 035001-)	Delco-Remy Bendix drive

Stator

Stator Size	25 amp
Resistance	0.064 - 0.20 ohms

SPECIFICATIONS & INFORMATION SPECIFICATIONS

Regulated Voltage at High Idle (minimum)	13.8 - 14.7 volts
Unregulated Voltage at 3600 rpm	28 VAC

Fuel/Air System

Carburetor Slow Idle Mixture Screw Initial Setting	Lightly Seat, Then 1 Turn Out
Slow Idle Speed	1200 ± 75 rpm
Fast Idle Speed	2950 ± 100 rpm
Fuel Tank Location	Right side of operator
Fuel Tank Capacity	18.9 L (5 gal)
Fuel (Minimum Octane)	Unleaded gasoline, 87 octane
Fuel Delivery	Pulse
Carburetor	Float-type, fixed main jet, one barrel
Fuel Filter	Replaceable, in-line
Fuel Shutoff Solenoid	In carburetor float bowl

Powertrain

Transaxle Gear Teeth

Bevel Pinion Gear (input shaft)	13
---	----

Drive Shaft

Bevel Drive Gear	42
Reverse Sprocket Gear	14
1st Gear	41
2nd Gear	37
3rd Gear	35
4th Gear	34
Spur Gear	15

Counter Shaft

Drive Sprocket Gear	14
1st Gear	9
2nd Gear	12
3rd Gear	15
4th Gear	16
Output Gear	35
Bevel Gear	33
Differential Ring Gear	31
Differential Miter Bevel Gears (axle shafts)	16
Differential Pinion Gears (cross shaft)	14

Lubrication

Capacity (grease)	1.0 L (30 oz)
Input Shaft Needle Bearings Grease	Unirex® N3 Grease Only
Transaxle Housing Grease	Bentonite Grease Only

SPECIFICATIONS & INFORMATION SPECIFICATIONS

Hydraulic System

Pump Type	Parker 165AYS65-GLL-1H-25-15-Y
System Capacity	1.9 L (2.0 qt)
Fill Level	12.7 - 19 mm (1/2" - 3/4" below fill plug)

Brakes

Park Brake	Disc, hand lever actuated
------------	---------------------------

Wheels and Tires

Tire Pressure	62 kPa (9 psi)
---------------	----------------

Dimensions

Weight	575 kg (1267 lb)
Height	1067 mm (42 in.)
Width	1470 mm (60 in.)
Length	2134 mm (84 in.)
Coring Width	800 mm (31.5 in.)

Tine Hole Pattern

1st Gear (using mini tines)	35.6 mm x 35.6 mm (1.4 in. x 1.4 in.)
2nd Gear*	50.8 mm x 50.8 mm (2.0 in. x 2.0 in.)
3rd Gear*	66 mm x 50.8 mm (2.6 in. x 2.0 in.)
4th Gear*	73.6 mm x 50.8 mm (2.9 in. x 2.0 in.)

Tine Sizes

Tubular	10 mm (3/8 in.), 12.7 mm (1/2 in.), 16 mm (5/8 in.)
Solid	6.4 mm (1/4 in.), 16 mm (5/8 in.)
Mini-Tine (open side)	6.4 mm (1/4 in.)

Aercore 1000

Weight	392 kg (865 lb)
Height	990 mm (39 in.)
Width	1.2 m (45.7 in.)
Coring Width	952 mm (37.5 in.)
Coring Depth (Maximum)	100 mm (4.0 in.)
Tine Hole Pattern (dependent on machine speed)	30 mm x 50 mm to 127 mm

Tine Sizes

Tubular	10 mm (3/8 in.), 12.7 mm (1/2 in.), 16 mm (5/8 in.), 19 mm (3/4 in.)
Solid	6.4 mm (1/4 in.), 16 mm (5/8 in.)
Mini-Tine (open side)	6.4 mm (1/4 in.), 19 mm (3/4 in.)

Machine Requirements

Speed (in gear - working)	2 - 4.8 km/h (1.2 - 3 mph)
Speed (transport)	24 km/h (15 mph)
PTO Speed @ Machine WOT	540 rpm

SPECIFICATIONS & INFORMATION SPECIFICATIONS

Aercore 1500

Weight	499 kg (1100 lb)
Height	990 mm (39 in.)
Width	1.7 m (65.5 in.)
Coring Width	1.5 m (57.5 in.)
Coring Depth (Maximum)	100 mm (4.0 in.)
Tine Hole Pattern (dependent on Machine speed)	30 mm x 50 mm to 127 mm

Tine Sizes

Tubular	10 mm (3/8 in.), 12.7 mm (1/2 in.), 16 mm (5/8 in.), 19 mm (3/4 in.)
Solid	6.4 mm (1/4 in.), 16 mm (5/8 in.)
Mini-Tine (open side)	6.4 mm (1/4 in.), 19 mm (3/4 in.)

Machine Requirements

Speed (in gear - working)	2 - 4.8 km/h (1.2 - 3 mph)
Speed (transport)	24 km/h (15 mph)
PTO Speed @ Machine WOT	540 rpm

Aercore 2000

Weight	772 kg (1728 lb)
Height	990 mm (39 in.)
Width	2.2 m (85.7 in.)
Coring Width	2.0 m (77.5 in.)
Coring Depth (Maximum)	100 mm (4.0 in.)
Tine Hole Pattern (dependent on Machine speed)	30 mm x 50 mm to 127 mm

Tine Sizes

Tubular	10 mm (3/8 in.), 12.7 mm (1/2 in.), 16 mm (5/8 in.), 19 mm (3/4 in.)
Solid	6.4 mm (1/4 in.), 16 mm (5/8 in.)
Mini-Tine (open side)	6.4 mm (1/4 in.), 19 mm (3/4 in.)



Machine Requirements

Speed (in gear - working)	2 - 4.8 km/h (1.2 - 3 mph)
Speed (transport)	24 km/h (15 mph)
PTO Speed @ Machine WOT	540 rpm

SPECIFICATIONS & INFORMATION FASTENER TORQUES

Fastener Torques

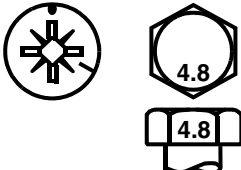
Metric Fastener Torque Values

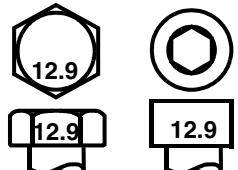
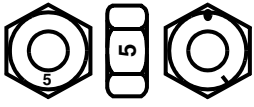
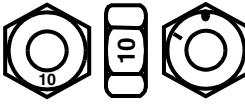
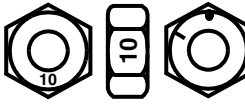
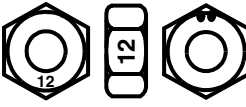
Property Class and Head Markings	<p>4.8</p> 	<p>8.8 9.8</p> 	<p>10.9</p> 	<p>12.9</p> 
Property Class and Nut Markings	<p>5</p> 	<p>10</p> 	<p>10</p> 	<p>12</p> 

MIF

SIZE	Class 4.8		Class 8.8 or 9.8				Class 10.9				Class 12.9					
	Lubricated a		Dry a		Lubricated a		Dry a		Lubricated a		Dry a		Lubricated a		Dry a	
	N•m	lb-ft	N•m	lb-ft	N•m	lb-ft	N•m	lb-ft	N•m	lb-ft	N•m	lb-ft	N•m	lb-ft	N•m	lb-ft
M6	4.8	3.5	6	4.5	9	6.5	11	8.5	13	9.5	17	12	15	11.5	19	14.5
M8	12	8.5	15	11	22	16	28	20	32	24	40	30	37	28	47	35
M10	23	17	29	21	43	32	55	40	63	47	80	60	75	55	95	70
M12	40	29	50	37	75	55	95	70	110	80	140	105	130	95	165	120
M14	63	47	80	60	120	88	150	110	175	130	225	165	205	150	260	109
M16	100	73	125	92	190	140	240	175	275	200	350	225	320	240	400	300
M18	135	100	175	125	260	195	330	250	375	275	475	350	440	325	560	410
M20	190	140	240	180	375	275	475	350	530	400	675	500	625	460	800	580
M22	260	190	330	250	510	375	650	475	725	540	925	675	850	625	1075	800
M24	330	250	425	310	650	475	825	600	925	675	1150	850	1075	800	1350	1000
M27	490	360	625	450	950	700	1200	875	1350	1000	1700	1250	1600	1150	2000	1500
M30	675	490	850	625	1300	950	1650	1200	1850	1350	2300	1700	2150	1600	2700	2000
M33	900	675	1150	850	1750	1300	2200	1650	2500	1850	3150	2350	2900	2150	3700	2750
M36	1150	850	1450	1075	2250	1650	2850	2100	3200	2350	4050	3000	3750	2750	4750	3500

DO NOT use these hand torque values if a different torque value or tightening procedure is given for a specific application. Torque values listed are for general use only and include a $\pm 10\%$ variance factor. Check tightness of fasteners periodically. DO NOT use air powered wrenches.

Shear bolts are designed to fail under predetermined loads. Always replace shear bolts with identical grade.

Fasteners should be replaced with the same grade. Make sure fastener threads are clean and that you properly start thread engagement. This will prevent them from failing

when tightening.

When bolt and nut combination fasteners are used, torque values should be applied to the NUT instead of the bolt head.

Tighten toothed or serrated-type lock nuts to the full torque value.

a "Lubricated" means coated with a lubricant such as engine oil, or fasteners with phosphate and oil coatings. "Dry" means plain or zinc plated (yellow dichromate - Specification JDS117) without any lubrication.







SPECIFICATIONS & INFORMATION FASTENER TORQUES

Reference: JDS - G200.

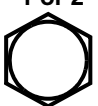
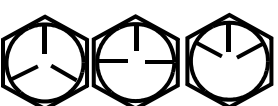

SPECIFICATIONS & INFORMATION FASTENER TORQUES

Inch Fastener Torque Values

SAE Grade and Head Markings	1 or 2 ^b No Marks 	5 5.1 5.2 	8 8.2 
SAE Grade and Nut Markings	2 No Marks 	5  	8  

MIF

SIZE	Grade 1		Grade 2b				Grade 5, 5.1 or 5.2				Grade 8 or 8.2					
	Lubricated a		Dry a		Lubricated a		Dry a		Lubricated a		Dry a		Lubricated a		Dry a	
	N•m	lb-ft	N•m	lb-ft	N•m	lb-ft	N•m	lb-ft	N•m	lb-ft	N•m	lb-ft	N•m	lb-ft	N•m	lb-ft
1/4	3.7	2.8	4.7	3.5	6	4.5	7.5	5.5	9.5	7	12	9	13.5	10	17	12.5
5/16	7.7	5.5	10	7	12	9	15	11	20	15	25	18	28	21	35	26
3/8	14	10	17	13	22	16	27	20	35	26	44	33	50	36	63	46
7/16	22	16	28	20	35	26	44	32	55	41	70	52	80	58	100	75
1/2	33	25	42	31	53	39	67	50	85	63	110	80	120	90	150	115
9/16	48	36	60	45	75	56	95	70	125	90	155	115	175	130	225	160
5/8	67	50	85	62	105	78	135	100	170	125	215	160	215	160	300	225
3/4	120	87	150	110	190	140	240	175	300	225	375	280	425	310	550	400
7/8	190	140	240	175	190	140	240	175	490	360	625	450	700	500	875	650
1	290	210	360	270	290	210	360	270	725	540	925	675	1050	750	1300	975
1-1/8	470	300	510	375	470	300	510	375	900	675	1150	850	1450	1075	1850	1350
1-1/4	570	425	725	530	570	425	725	530	1300	950	1650	1200	2050	1500	2600	1950
1-3/8	750	550	950	700	750	550	950	700	1700	1250	2150	1550	2700	2000	3400	2550
1-1/2	1000	725	1250	925	990	725	1250	930	2250	1650	2850	2100	3600	2650	4550	3350

DO NOT use these hand torque values if a different torque value or tightening procedure is given for a specific application. Torque values listed are for general use only and include a ±10% variance factor. Check tightness of fasteners periodically. DO NOT use air powered wrenches.

Shear bolts are designed to fail under predetermined loads. Always replace shear bolts with identical grade.

Fasteners should be replaced with the same grade. Make sure fastener threads are clean and that you properly start thread engagement. This will prevent them from failing when tightening.

When bolt and nut combination fasteners are used, torque values should be applied to the NUT instead of the bolt

head.

Tighten toothed or serrated-type lock nuts to the full torque value.

a "Lubricated" means coated with a lubricant such as engine oil, or fasteners with phosphate and oil coatings. "Dry" means plain or zinc plated (yellow dichromate - Specification JDS117) without any lubrication.

b "Grade 2" applies for hex cap screws (Not Hex Bolts) up to 152 mm (6 in.) long. "Grade 1" applies for hex cap screws over 152 mm (6 in.) long, and for all other types of bolts and screws of any length.

Reference: JDS - G200

SPECIFICATIONS & INFORMATION O-RING SEAL SERVICE

O-Ring Seal Service Recommendations

Face Seal Fittings With Inch Stud Ends Torque

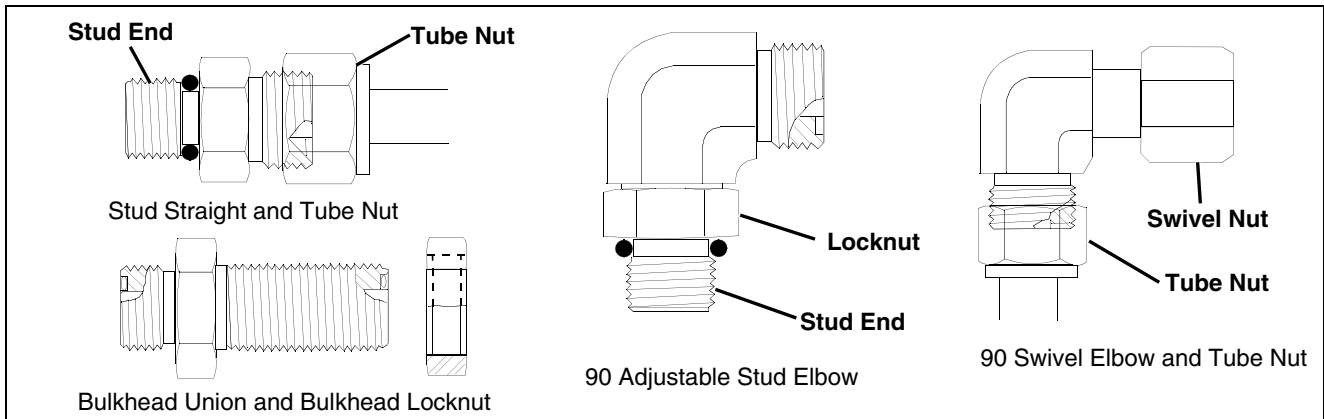

MIF

Nominal Tube OD/Hose ID				Face Seal Tube/Hose End				O-Ring Stud Ends			
Metric Tube OD	Inch Tube OD			Thread Size	Tube Nut/ Swivel Nut Torque		Bulkhead Lock Nut Torque		Thread Size	Straight Fitting or Lock Nut Torque	
	Dash Size	in.	mm		in.	N•m	lb-ft	N•m		lb-ft	in.
5	-3	0.188	4.76						3/8-24	8	6
6	-4	0.250	6.35	9/16-18	16	12	12	9	7/16-20	12	9
8	-5	0.312	7.94						1/2-20	16	12
10	-6	0.375	9.52	11/16-16	24	18	24	18	9/16-18	24	18
12	-8	0.500	12.70	13/16-16	50	37	46	34	3/4-16	46	34
16	-10	0.625	15.88	1-14	69	51	62	46	7/8-14	62	46
19	-12	0.750	19.05	1-3/16-12	102	75	102	75	1-1/16-12	102	75
22	-14	0.875	22.22	1-3/16-12	102	75	102	75	1-3/16-12	122	90
25	-16	1.000	25.40	1-7/16-12	142	105	142	105	1-5/16-12	142	105
32	-20	1.25	31.75	1-11/16-12	190	140	190	140	1-5/8-12	190	140
38	-24	1.50	38.10	2-12	217	160	217	160	1-7/8-12	217	160

NOTE: Torque tolerance is +15%, -20%

SPECIFICATIONS & INFORMATION O-RING SEAL SERVICE

Face Seal Fittings With Metric Stud Ends Torque

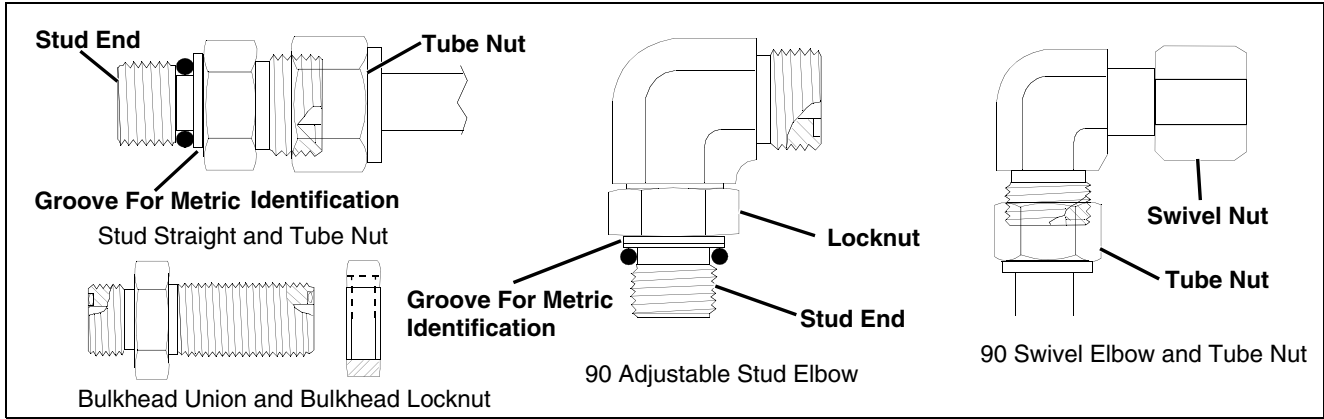

Nominal Tube OD/Hose ID				Face Seal Tube/Hose End						O-Ring Stud Ends, Straight Fitting or Lock Nut					
Metric Tube OD	Inch Tube OD			Thread Size	Hex Size	Tube Nut/ Swivel Nut Torque		Bulkhead Lock Nut Torque		Thread Size	Hex Size	Steel or Gray Iron Torque		Aluminum Torque	
	Dash Size	in.	mm			in.	mm	N•m	lb-ft			N•m	lb-ft	mm	mm
6	-4	0.250	6.35	9/16-18	17	16	12	12	9	M12X1.5	17	21	15.5	9	6.6
8	-5	0.312	7.94												
										M14X1.5	19	33	24	15	11
10	-6	0.375	9.52	11/16-16	22	24	18	24	18	M16X1.5	22	41	30	18	13
12	-8	0.500	12.70	13/16-16	24	50	37	46	34	M18X1.5	24	50	37	21	15
16	-10	0.625	15.88	1-14	30	69	51	62	46	M22X1.5	27	69	51	28	21
	-12	0.750	19.05	1-3/16-12	36	102	75	102	75	M27X2	32	102	75	46	34
22	-14	0.875	22.22	1-3/16-12	36	102	75	102	75	M30X2	36				
25	-16	1.000	25.40	1-7/16-12	41	142	105	142	105	M33X2	41	158	116	71	52
28										M38X2	46	176	130	79	58
32	-20	1.25	31.75	1-11/16-12	50	190	140	190	140	M42X2	50	190	140	85	63
38	-24	1.50	38.10	2-12	60	217	160	217	160	M48X2	55	217	160	98	72

NOTE: Torque tolerance is +15%, -20%

SPECIFICATIONS & INFORMATION O-RING SEAL SERVICE

O-Ring Face Seal Fittings

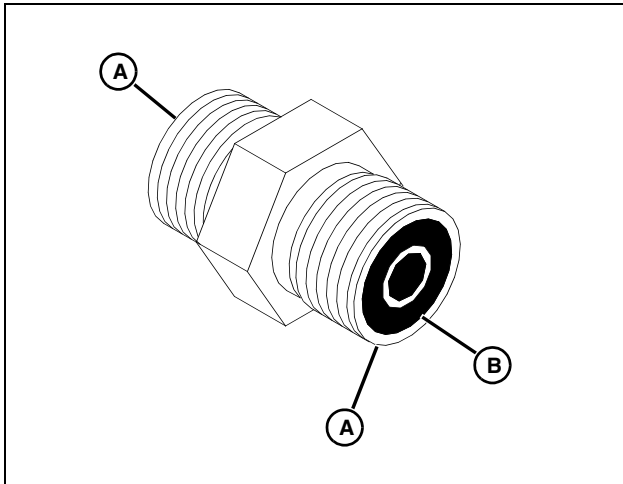

1. Inspect the fitting sealing surfaces (A). They must be free of dirt or defects.
2. Inspect the O-ring (B). It must be free of damage or defects.
3. Lubricate O-rings and install into groove using petroleum jelly to hold in place during assembly.
4. Index angle fittings and tighten by hand pressing joint together to insure O-ring remains in place.

IMPORTANT: Avoid damage! DO NOT allow hoses to twist when tightening fittings. Use two wrenches to tighten hose connections; one to hold the hose, and the other to tighten the swivel fitting.

5. Tighten fitting or nut to torque value shown on the chart per dash size stamped on the fitting.

O-Ring Boss Fittings

1. Inspect boss O-ring boss seat. It must be free of dirt and defects. If repeated leaks occur, inspect for defects with a magnifying glass. Some raised defects can be removed with a slip stone.

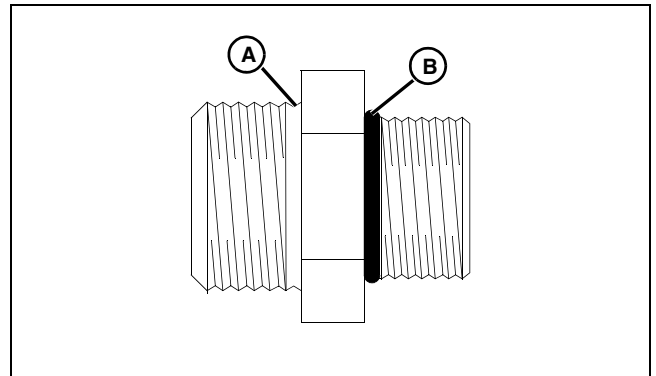

2. Put hydraulic oil or petroleum jelly on the O-ring (B). Place electrical tape over the threads to protect O-ring from nicks. Slide O-ring over the tape and into the groove (A) of fitting. Remove tape.

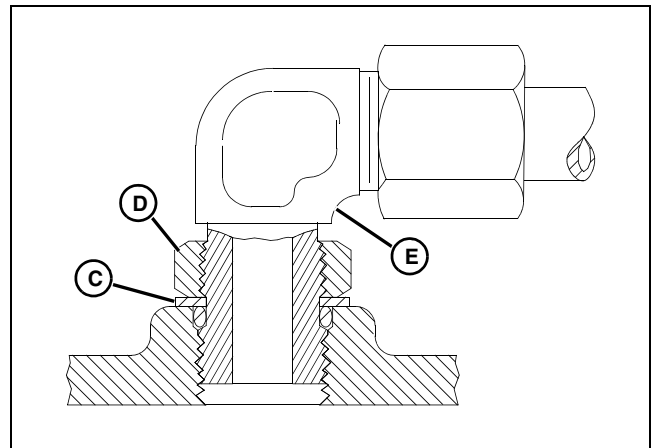

3. For angle fittings, loosen special nut (D) and push special washer (C) against threads so O-ring can be installed into the groove of fitting.
4. Turn fitting into the boss by hand until special washer or washer face (straight fitting) contacts boss face and O-ring is squeezed into its seat.
5. To position angle fittings (E), turn the fitting counter-clockwise a maximum of one turn.
6. Tighten straight fittings to torque value shown on chart. For angle fittings, tighten the special nut to value shown in the chart while holding body of fitting with a wrench.

SPECIFICATIONS & INFORMATION GENERAL INFORMATION

Straight Fitting or Special Nut Torques

Thread Size	Torque ^a		Number of Flats ^b
	N•m	lb-ft	
3/8-24 UNF	8	6	2
7/16-20 UNF	12	9	2
1/2-20 UNF	16	12	2
9/16-18 UNF	24	18	2
3/4-16 UNF	46	34	2
7/8-14 UNF	62	46	1-1/2
1-1/16-12 UN	102	75	1
1-3/16-12 UN	122	90	1
1-5/16-12 UN	142	105	3/4
1-5/8-12 UN	190	140	3/4
1-7/8-12 UN	217	160	1/2

^aTorque tolerance is \pm 10 percent.

^bTo be used if a torque wrench cannot be used. After tightening fitting by hand, put a mark on nut or boss; then tighten special nut or straight fitting the number of flats shown.

Metric Fastener Torque Value - Grade 7 (Special)

Size	Steel or Gray Iron Torque	Aluminum Torque
	N•m (lb-ft)	N•m (lb-ft)
M6	11 (8)	8 (6)
M8	24 (18)	19 (14)
M10	52 (38)	41 (30)
M12	88 (65)	70 (52)
M14	138 (102)	111 (82)
M16	224 (165)	179 (132)

General Information

Using Proper Fuel

Use regular grade unleaded fuel with an octane rating of 87 octane or higher. Fuel blends containing up to 10% ethanol or up to 15% MTBE reformulated fuel are acceptable. Do not use fuel or additives containing methanol as engine damage can occur.

Always use fresh, clean fuel that is purchased in a quantity that can be used within approximately 30 days, or add fuel stabilizer.

Fuel is blended to give best seasonal performance. To avoid engine performance problems such as hard starting or vapor lock, use in-season fuel. Use fuel during warm weather that was purchased during that season, and use fuel during cold weather that was purchased during that season.

Fuel can become stale in machines with engines that are used seasonally or infrequently during a season. Stale fuel can produce varnish and plug carburetor or injector components which can affect engine performance.

Keep fuel storage container tightly covered and in a cool area out of direct sunlight. Fuel can break down and degrade if not sealed properly or exposed to sun and heat.

Condensation may collect in the fuel tank because of a variety of operating or environmental conditions and, over time, may affect your machine's operation. Fill fuel tank at the end of daily use and store fuel in plastic containers to reduce condensation.

For best year-round performance and fuel-handling, add stabilizer to fuel immediately after fuel purchase. Such practice helps prevent engine performance problems and allows fuel storage in the machine all year without draining.

4 - Cycle Gasoline Engine Oil

Use the appropriate oil viscosity based on the expected air temperature range during the period between recommended oil changes. Operating outside of these recommended oil air temperature ranges may cause premature engine failure.

The following John Deere oils are **PREFERRED**:

- **PLUS - 4@ - SAE 10W-40;**
- **TORQ - GARD SUPREME® - SAE 5W-30.**

The following John Deere oils are **also recommended**, based on their specified temperature range:

- **TURF - GARD® - SAE 10W-30;**
- **PLUS - 4@ - SAE 10W-30;**
- **TORQ - GARD SUPREME® - SAE 30.**

SPECIFICATIONS & INFORMATION GENERAL INFORMATION

Other oils may be used if above John Deere oils are not available, provided they meet one of the following specifications:

- SAE 10W-40 - API Service Classifications SG or higher;
- SAE 5W-30 - API Service Classification SG or higher;
- SAE 10W-30 - API Service Classifications SG or higher;
- SAE 30 - API Service Classification SC or higher.

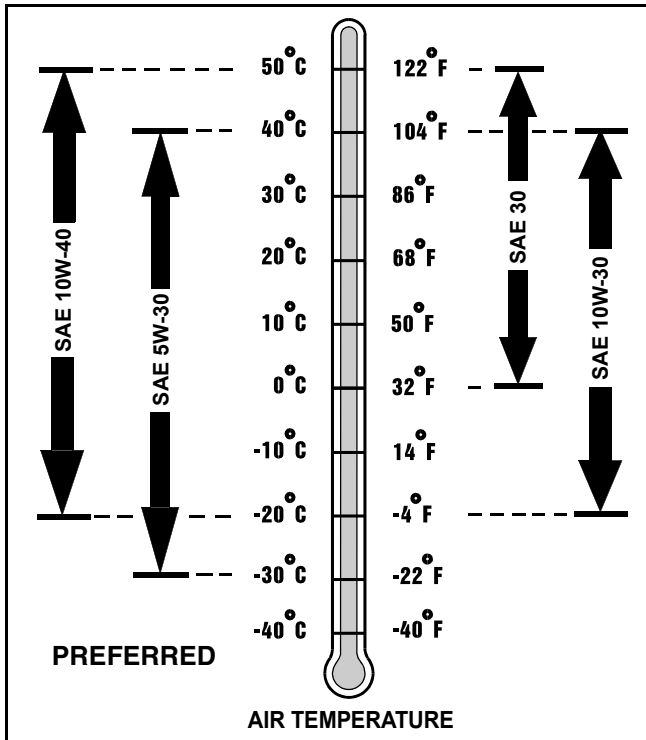

Gear Case Oil

Use the appropriate oil viscosity based on the air temperature ranges. Operating outside of these recommended oil air temperature ranges may cause premature gear case failure.

IMPORTANT: Avoid damage! ONLY use a quality oil in this gear case. DO NOT mix any other oils in this gear case. DO NOT use BIO-HY-GARD® in this gear case.

The following John Deere gear case oil is PREFERRED:

- **GL-5 GEAR LUBRICANT® - SAE 80W-90.**

The following John Deere gear case oil is also recommended if above preferred oil is not available:

- **GL-5 GEAR LUBRICANT® - SAE 85W-140.**

Other gear case oils may be used if above recommended John Deere gear case oils are not available, provided they meet the following specification:

- API Service Classification GL - 5.

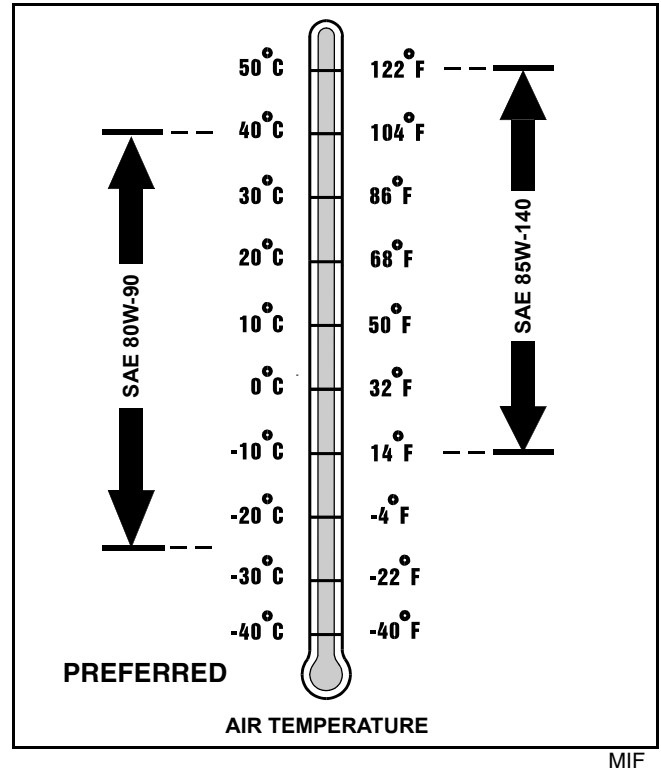

Hydraulic Pump Oil

The following John Deere oil is PREFERRED:

- Bio-Hygard™

Transaxle Housing Grease

The following grease is PREFERRED:

- Bentonite grease

Gear Transmission Grease

Use the following gear grease based on the air temperature range. Operating outside of the recommended grease air temperature range may cause premature gear transmission failure.

IMPORTANT: Avoid damage! ONLY use a quality gear grease in this transmission. DO NOT mix any other greases in this transmission. DO NOT use any BIO - GREASE in this transmission.

The following John Deere gear grease is PREFERRED:

- **NON-CLAY HIGH-TEMPERATURE EP GREASE® - JDM J13E4, NLGI Grade 2.**

Other greases may be used if above preferred John Deere grease is not available, provided they meet the following specification:

SPECIFICATIONS & INFORMATION GENERAL INFORMATION

- John Deere Standard JDM J13E4, NLGI Grade 2.

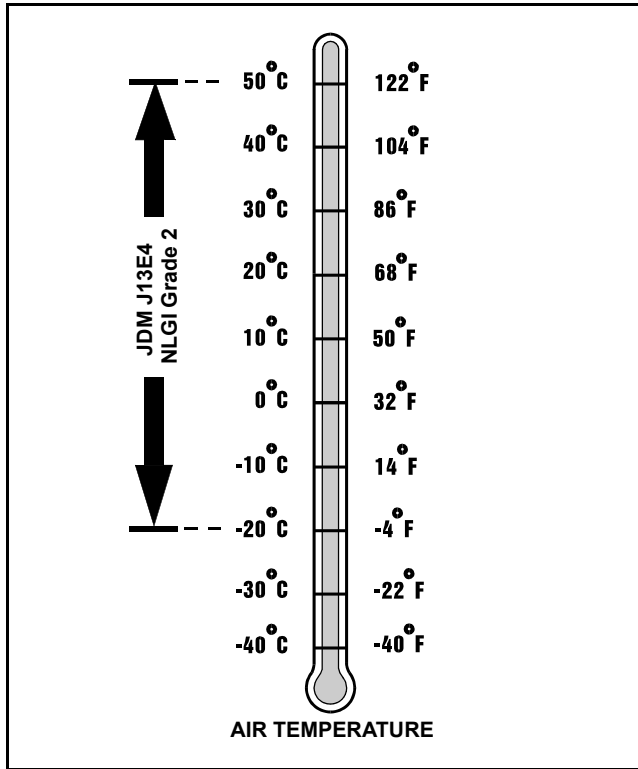

MIF

Alternative Lubricants

Use of alternative lubricants could cause reduced life of the component.

If alternative lubricants are to be used, it is recommended that the factory fill be thoroughly removed before switching to any alternative lubricant.

Synthetic Lubricants

Synthetic lubricants may be used in John Deere equipment if they meet the applicable performance requirements (industry classification and/or military specification) as shown in this manual. Do not use other than factory approved alternative/synthetic lubricants.

The recommended air temperature limits and service or lubricant change intervals should be maintained as shown in the operator's manual, unless otherwise stated on lubricant label.

Avoid mixing different brands, grades, or types of oil. Oil manufacturers blend additives in their oils to meet certain specifications and performance requirements. Mixing different oils can interfere with the proper functioning of these additives and degrade lubricant performance.

Lubricant Storage

All machines operate at top efficiency only when clean lubricants are used. Use clean storage containers to handle all lubricants. Store them in an area protected from dust, moisture, and other contamination. Store drums on their sides. Make sure all containers are properly marked as to their contents. Dispose of all old, used containers and their contents properly.

Mixing of Lubricants

In general, avoid mixing different brands or types of lubricants. Manufacturers blend additives in their lubricants to meet certain specifications and performance requirements. Mixing different lubricants can interfere with the proper functioning of these additives and lubricant properties which will downgrade their intended specified performance.

Oil Filters

IMPORTANT: Avoid damage! Filtration of oils is critical to proper lubrication performance. Always change filters regularly.

The following John Deere oil filters are PREFERRED:

- AUTOMOTIVE AND LIGHT TRUCK ENGINE OIL FILTERS.

Most John Deere filters contain pressure relief and anti-drainback valves for better engine protection.

Other oil filters may be used if above recommended John Deere oil filters are not available, provided they meet the following specification:

- ASTB Tested In Accordance With SAE J806.

SPECIFICATIONS & INFORMATION SERIAL NUMBER LOCATIONS

Serial Number Locations

Product Serial Number (800)

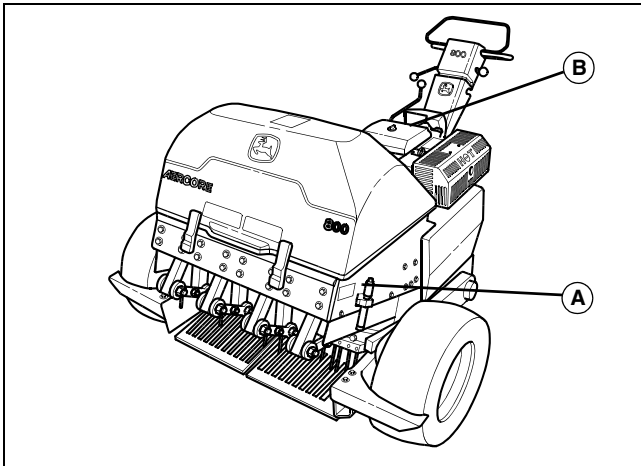

MIF

The product identification number (A) is located on the left side. The engine number (B) is on the top of the engine.

Product Serial Number (1000, 1500 and 2000)



MX4616

The product identification number (A) is located on the front.

ENGINE - GAS TABLE OF CONTENTS

Table of Contents

Specifications25

General Engine Specifications25

Test and Adjustment Specifications25

Repair Specifications.....25

Torque Specifications28

Tools and Materials29

Service Equipment and Tools29

Essential Tools29

Other Materials.....30

Component Location.....31

Engine31

Carburetor32

Diagnostics33

Main Components33

Engine Hard To Start and/or Engine Starter

Kicks Out.....34

Tests and Adjustments35

Cylinder Leakdown Test.....35

Crankcase Vacuum Test35

Fuel Flow Test.....37

Oil Pressure Test.....37

Throttle Solenoid Adjustment38

Governor Adjustment39

Carburetor Float Adjustment40

Slow Idle Speed Adjustment41

Repair.....42

Fuel Tank Removal and Installation.....42

Fuel Filter Removal and Installation42

Air Intake System Removal,

Servicing, and Installation43

Fuel Pump Removal and Installation.....44

Carburetor Removal and Installation.....44

Carburetor Disassembly and Assembly45

Blower Housing and Shields

Removal and Installation46

Muffler and Intake Manifold

Removal and Installation46

Engine Removal and Installation.....47

Engine Drive Sheave

Removal and Installation48

Breather Removal and Installation48

Rocker Arms and Push Rods

Removal and Installation49

Push Rod Inspection49

Cylinder Heads Removal and Installation.... 49

Valves and Springs
Removal and Installation 50

Cylinder Head Inspection 51

Valve Inspection 51

Analyze Valves 51

Valve Guides Inspection 52

Recondition Valve Seats..... 53

Lap Valves..... 53

Flywheel and Stator

Removal and Installation 54

Closure Plate Removal and Installation 55

Governor Removal and Installation 56

Oil Pump Removal and Installation..... 57

Camshaft Removal and Installation 57

Camshaft Inspection 58

Camshaft End Play 58

Hydraulic Lifters Removal and Installation... 59

Hydraulic Lifters Inspection..... 59

Priming Hydraulic Lifters..... 60

Bleeding Hydraulic Lifters 60

Piston Assembly

Removal and Disassembly 60

Piston Pin Removal,

Inspection, and Installation 61

Piston Measurement..... 62

Cylinder Bore Measurement..... 62

Analyze Piston Ring Wear 62

Analyze Piston Wear 63

Piston Ring End Gap Measurement 65

Piston Ring Side Clearance..... 65

Piston Rings Installation 65

Crankshaft Removal and Installation 66

Crankshaft Journal Measurement..... 66

Crankshaft Alignment 67

Regrind Crankshaft (Optional) 67

Engine Block and Closure Plate

Crankshaft Bore Measurement..... 67

Engine Block and Closure Plate

Seals Removal and Installation 68

Piston Assembly Installation 68

Connecting Rod Installation..... 68

Cylinder Block Inspection 69

Cylinder Bore Deglazing 69

Cylinder Block Rebore 70

Remove and Install Starting Motor 71

Starting Motor

Disassembly and Assembly (SN -035000) .. 71

ENGINE - GAS TABLE OF CONTENTS

Starting Motor

Disassembly and Assembly (SN 035001-)...71

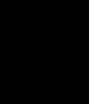

ENGINE - GAS SPECIFICATIONS

Specifications

General Engine Specifications

Make	Kohler
Type	OHV, horizontal shaft, 4-cycle, V-twin
Engine Model Number	CH730S
Aspiration	Natural
Bore	83 mm (3.27 in.)
Stroke	67 mm (2.64 in.)
Displacement	725 cm ³ (44 cu in.)
Cylinders	2
Ignition	Electronic
High Idle Setting	3000 rpm
Low Idle Setting	1200 rpm
Compression Ratio	9.0:1
Lubrication	Full Pressure with Full Flow Filter
Cooling System	Air Cooled
Oil Capacity (with filter)	2.0 L (2.1 qt)
Hydraulic Pump Capacity	1.9 L (2.0 qt)
Air Cleaner	Dual-stage, dry, replaceable
Oil Filter	Replaceable, full flow

Test and Adjustment Specifications

Engine

Spark Plug Gap	0.76 mm (0.030 in.)
Valve Adjustment	None (hydraulic lifters)
Oil Pressure (Minimum at 1250 rpm)	124 kPa (18 psi)
Crankcase Vacuum (Minimum At Operating Temperature)	10.2 cm (4 in.) Water Movement

Fuel/Air System

Carburetor Slow Idle Mixture Screw Initial Setting	Lightly Seat, Then 1 Turn Out
Slow Idle Speed	1200 ± 75 rpm
Fast Idle Speed	2950 ± 100 rpm

Repair Specifications

Cylinder Head

Cylinder Head Flatness (Maximum Warping)	0.076 mm (0.003 in.)
--	----------------------

Push Rod

Maximum Bend	0.76 mm (0.030 in.)
--------------	---------------------

Valves and Valve Lifters

Hydraulic Lifter-to-Crankcase Running Clearance	0.0124 - 0.0501 mm (0.0005 - 0.0020 in.)
Intake Valve Stem-to-Valve Guide Running Clearance	0.038 - 0.076 mm (0.0015 - 0.0030 in.)
Exhaust Valve Stem-to-Valve Guide Running Clearance	0.050 - 0.088 mm (0.0020 - 0.0035 in.)

ENGINE - GAS SPECIFICATIONS

Product: John Deere Aercore Aerator 800, 1000, 1500, and 2000 Service Repair Technical Manual

Full Download: [https://www.bobmanualstore.com/downloads/john-deere-aercore-](https://www.bobmanualstore.com/downloads/john-deere-aercore-aerator-800-1000-1500-and-2000-service-repair-technical-manu)

Intake Valve Guide ID	
New	7.038 - 7.058 mm (0.2771 - 0.2779 in.)
Maximum Wear Limit	7.134 mm (0.2809 in.)
Exhaust Valve Guide ID	
New	7.038 - 7.058 mm (0.2771 - 0.2779 in.)
Maximum Wear Limit	7.159 mm (0.2819 in.)
Valve Guide Reamer	
Standard	7.048 mm (0.2775 in.)
Oversize (0.25 mm)	7.298 mm (0.2873 in.)
Intake Valve Lift (Minimum - Engine Cold)	8.07 mm (0.3177 in.)
Exhaust Valve Lift (Minimum - Engine Cold)	8.07 mm (0.3177 in.)
Valve Seat Angle	45°
Crankshaft	
End Play (Free)	0.070 - 0.480 mm (0.0028 - 0.0189 in.)
Crankshaft Sleeve Bearing (Crankcase) - New	0.03 - 0.09 mm (0.0012 - 0.0035 in.)
Crankshaft Sleeve Bearing ID (Crankcase) - New	40.965 - 41.003 mm (1.6128 - 1.6143 in.)
Maximum Wear Limit	41.016 mm (1.6148 in.)
Crankshaft Bore (In Closure Plate) - New	40.974 - 41.003 mm (1.6128 - 1.6143 in.)
Crankshaft Bore (In Closure Plate)-to-Crankshaft	
Running Clearance (New)	0.039 - 0.074 mm (0.0015 - 0.0029 in.)
Main Bearing Journal OD (Flywheel End)	
New	40.913 - 40.935 mm (1.6107 - 1.6116 in.)
Maximum Wear Limit	40.84 mm (1.608 in.)
Maximum Taper	0.022 mm (0.0009 in.)
Maximum Out-of-Round	0.025 mm (0.0010 in.)
Main Bearing Journal OD (Closure Plate End)	
New	40.913 - 40.935 mm (1.6107 - 1.6116 in.)
Maximum Wear Limit	40.84 mm (1.608 in.)
Maximum Taper	0.022 mm (0.0009 in.)
Maximum Out-of-Round	0.025 mm (0.0010 in.)
Crankshaft Total Indicated Runout (TIR)	
PTO End (Crankshaft in Engine)	0.15 mm (0.0059 in.)
Entire Crankshaft (In Bench V-Blocks)	0.10 mm (0.0039 in.)
Camshaft	
End Play (With Shim)	0.076 - 0.127 mm (0.003 - 0.005 in.)
Clearance	0.025 - 0.063 mm (0.0010 - 0.0025 in.)
Bore ID	
New	20.000 - 20.025 mm (0.7874 - 0.7884 in.)
Maximum Wear Limit	20.038 mm (0.7889 in.)
Bearing Surface OD	
New	19.962 - 19.975 mm (0.7859 - 0.7864 in.)
Maximum Wear Limit	19.959 mm (0.7858 in.)

Sample manual. Download All 264 pages at:

<https://www.bobmanualstore.com/downloads/john-deere-aercore-aerator-800-1000-1500-and-2000-service-repair-technical-manu>