

Product: John Deere ProGator HD200 and HD300 Sprayer Attachment Service Repair Technical Manual  
Full Download: <https://www.bobmanualstore.com/downloads/john-deere-progator-hd200-and-hd300-sprayer-attachment-service-repair-technical-manual/>

**JOHN DEERE**  
**WORLDWIDE COMMERCIAL & CONSUMER**  
**EQUIPMENT DIVISION**

---

**Sprayer Attachment for ProGator**  
**HD200 and HD300**

TM1829 DECEMBER 2004

**TECHNICAL MANUAL**



**JOHN DEERE**

North American Version  
Litho in U.S.A.

Sample manual. Download All 162 pages at:

<https://www.bobmanualstore.com/downloads/john-deere-progator-hd200-and-hd300-sprayer-attachment-service-repair-technical-manual/>

Product: John Deere ProGator HD200 and HD300 Sprayer Attachment Service Repair Technical Manual  
Full Download: <https://www.bobmanualstore.com/downloads/john-deere-progator-hd200-and-hd300-sprayer-attachment-service-repair-technical-manual/>

Sample manual. Download All 162 pages at:  
<https://www.bobmanualstore.com/downloads/john-deere-progator-hd200-and-hd300-sprayer-attachment-service-repair-technical-manual/>

# INTRODUCTION

---

---

## Manual Description

This technical manual is written for an experienced technician and contains sections that are specifically for this product. It is a part of a total product support program.

The manual is organized so that all the information on a particular system is kept together. The order of grouping is as follows:

- Table of Contents
- Specifications and Information
- Identification Numbers
- Tools and Materials
- Component Location
- Schematics and Harnesses
- Theory of Operation
- Operation and Diagnostics
- Diagnostics
- Tests and Adjustments
- Repair
- Other

***NOTE: Depending on the particular section or system being covered, not all of the above groups may be used.***

The bleed tabs for the pages of each section will align with the sections listed on this page. Page numbering is consecutive from the beginning of the Safety section through the last section.

We appreciate your input on this manual. If you find any errors or want to comment on the layout of the manual please contact us.

**Safety**

**Specifications and Information**

**Electrical**

**Pump**

**Sprayer**

**Miscellaneous**

All information, illustrations and specifications in this manual are based on the latest information at the time of publication. The right is reserved to make changes at any time without notice.

COPYRIGHT© 2004  
Deere & Co.  
John Deere Worldwide Commercial and  
Consumer Equipment Division  
All rights reserved  
Previous Editions  
COPYRIGHT© 1999, 2003

# INTRODUCTION

---

---

# SAFETY

## Recognize Safety Information

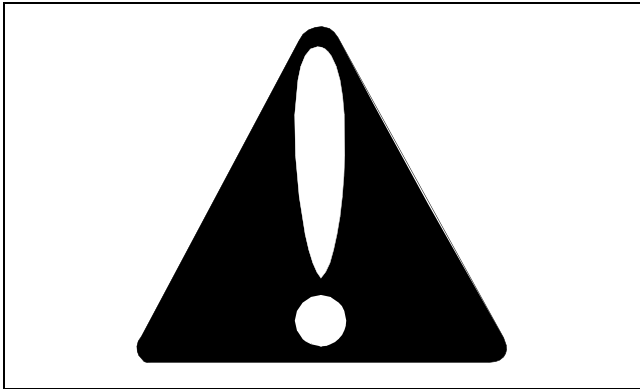

MIF

This is the safety-alert symbol. When you see this symbol on your machine or in this manual, be alert to the potential for personal injury.

Follow recommended precautions and safe servicing practices.

## Understand Signal Words

A signal word - DANGER, WARNING, or CAUTION - is used with the safety-alert symbol. DANGER identifies the most serious hazards.

DANGER or WARNING safety signs are located near specific hazards. General precautions are listed on CAUTION safety signs. CAUTION also calls attention to safety messages in this manual.

## Replace Safety Signs

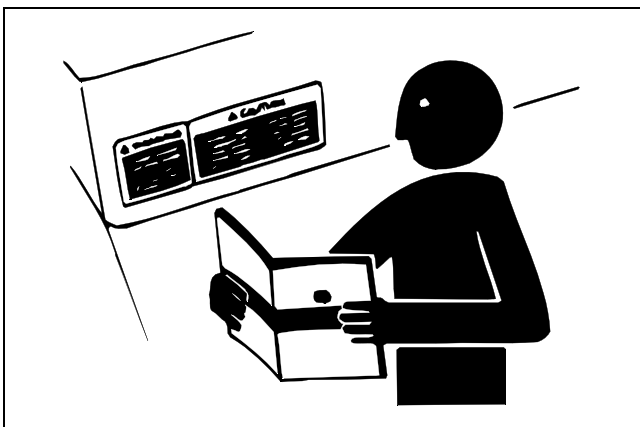

MIF

Replace missing or damaged safety signs. See the machine operator's manual for correct safety sign placement.

## Handle Fluids Safely - Avoid Fires

### Be Prepared For Emergencies

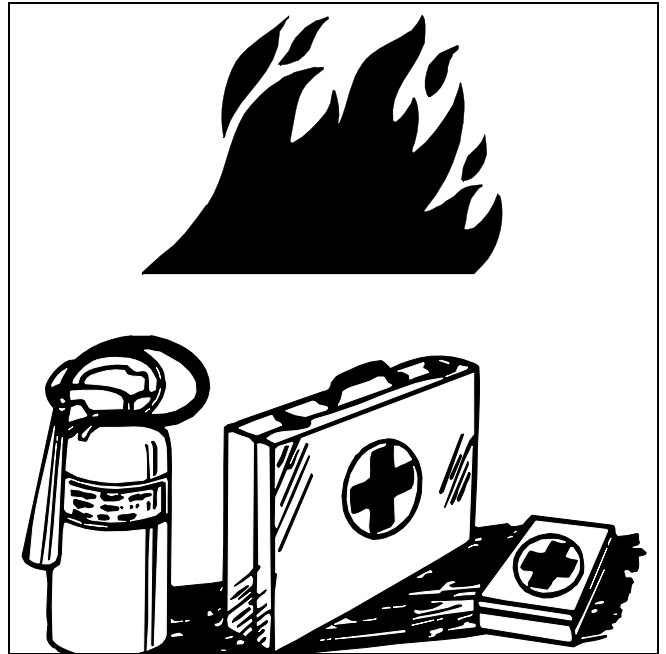

MIF

- When you work around fuel, do not smoke or work near heaters or other fire hazards.
- Store flammable fluids away from fire hazards. Do not incinerate or puncture pressurized containers.
- Make sure machine is clean of trash, grease, and debris.
- Do not store oily rags; they can ignite and burn spontaneously.
- Be prepared if a fire starts.
- Keep a first aid kit and fire extinguisher handy.
- Keep emergency numbers for doctors, ambulance service, hospital, and fire department near your telephone.

## Use Care In Handling and Servicing Batteries

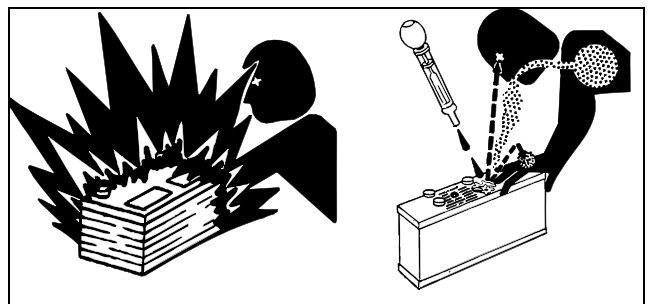

MIF

# SAFETY

## Prevent Battery Explosions

- Keep sparks, lighted matches, and open flame away from the top of battery. Battery gas can explode.
- Never check battery charge by placing a metal object across the posts. Use a volt-meter or hydrometer.
- Do not charge a frozen battery; it may explode. Warm battery to 16°C (60°F).

## Prevent Acid Burns

- Sulfuric acid in battery electrolyte is poisonous. It is strong enough to burn skin, eat holes in clothing, and cause blindness if splashed into eyes.

### Avoid acid burns by:

1. Filling batteries in a well-ventilated area.
2. Wearing eye protection and rubber gloves.
3. Avoiding breathing fumes when electrolyte is added.
4. Avoiding spilling or dripping electrolyte.
5. Use proper jump start procedure.

### If you spill acid on yourself:

1. Flush your skin with water.
2. Apply baking soda or lime to help neutralize the acid.
3. Flush your eyes with water for 10 - 15 minutes.
4. Get medical attention immediately.

### If acid is swallowed:

1. Drink large amounts of water or milk.
2. Then drink milk of magnesia, beaten eggs, or vegetable oil.
3. Get medical attention immediately.

## Wear Protective Clothing

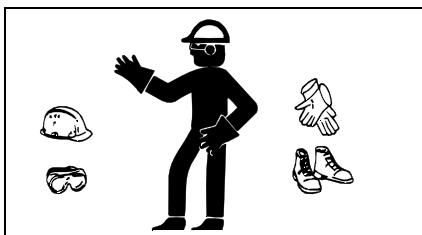

MIF

Wear close fitting clothing and safety equipment appropriate to the job.

Prolonged exposure to loud noise can cause impairment or loss of hearing. Wear a suitable hearing protective device such as earmuffs or earplugs to protect against objectionable or uncomfortable loud noises.

Operating equipment safely requires the full attention of the operator. Do not wear radio or music headphones while operating machine.

## Use Care Around High-Pressure Fluid Lines

### Avoid High-Pressure Fluids



MIF

Escaping fluid under pressure can penetrate the skin causing serious injury.

Avoid injury from escaping fluid under pressure by stopping the engine and relieving pressure in the system before disconnecting or connecting hydraulic or other lines. Tighten all connections before applying pressure.

Search for leaks with a piece of cardboard. Protect hands and body from high pressure fluids.

If an accident occurs, see a doctor immediately. Any fluid injected into the skin must be surgically removed within a few hours or gangrene may result. Doctors unfamiliar with this type of injury should reference a knowledgeable medical source. Such information is available from Deere & Company Medical Department in Moline, Illinois, U.S.A.

### Avoid Heating Near Pressurized Fluid Lines



MIF

Flammable spray can be generated by heating near pressurized fluid lines, resulting in severe burns to yourself and bystanders. Do not heat by welding, soldering, or using a torch near pressurized fluid lines or other flammable materials. Pressurized lines can be accidentally cut when heat goes beyond the immediate flame area.

# SAFETY

## Service Machines Safely

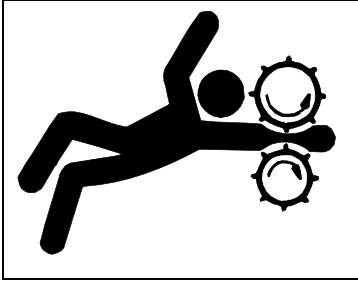

MIF

Tie long hair behind your head. Do not wear a necktie, scarf, loose clothing, or necklace when you work near machine tools or moving parts. If these items were to get caught, severe injury could result.

Remove rings and other jewelry to prevent electrical shorts and entanglement in moving parts.

## Use Proper Tools

Use tools appropriate to the work. Makeshift tools and procedures can create safety hazards. Use power tools only to loosen threaded parts and fasteners. For loosening and tightening hardware, use the correct size tools. Do not use U.S. measurement tools on metric fasteners. Avoid bodily injury caused by slipping wrenches. Use only service parts meeting John Deere specifications.

## Park Machine Safely

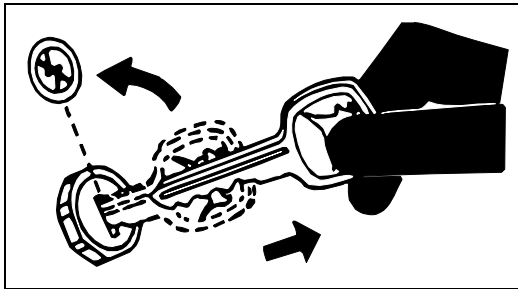

MIF

### Before working on the machine:

1. Lower all equipment to the ground.
2. Stop the engine and remove the key.
3. Disconnect the battery ground strap.
4. Hang a "Do Not Operate" tag in operator station.

## Support Machine Properly and Use Proper Lifting Equipment

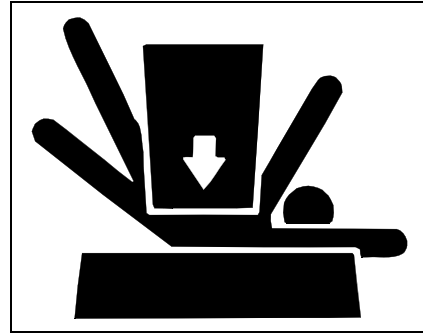

MIF

If you must work on a lifted machine or attachment, securely support the machine or attachment.

Do not support the machine on cinder blocks, hollow tiles, or props that may crumble under continuous load. Do not work under a machine that is supported solely by a jack. Follow recommended procedures in this manual.

Lifting heavy components incorrectly can cause severe injury or machine damage. Follow recommended procedure for removal and installation of components in the manual.

## Work In Clean Area

### Before starting a job:

1. Clean work area and machine.
2. Make sure you have all necessary tools to do your job.
3. Have the right parts on hand.
4. Read all instructions thoroughly; do not attempt shortcuts.

## Using High Pressure Washers

Directing pressurized water at electronic/electrical components or connectors, bearings, hydraulic seals, fuel injection pumps or other sensitive parts and components may cause product malfunctions. Reduce pressure and spray at a 45 to 90 degree angle.

## Illuminate Work Area Safely

Illuminate your work area adequately but safely. Use a portable safety light for working inside or under the machine. Make sure the bulb is enclosed by a wire cage. The hot filament of an accidentally broken bulb can ignite spilled fuel or oil.

# SAFETY

## Work In Ventilated Area

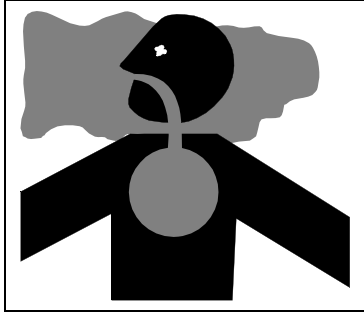

MIF

Engine exhaust fumes can cause sickness or death. If it is necessary to run an engine in an enclosed area, remove the exhaust fumes from the area with an exhaust pipe extension.

If you do not have an exhaust pipe extension, open the doors and get outside air into the area.

## Warning: California Proposition 65 Warning

Gasoline engine exhaust from this product contains chemicals known to the State of California to cause cancer, birth defects, or other reproductive harm.

Diesel engine exhaust and some of its constituents are known to the State of California to cause cancer, birth defects, and other reproductive harm.

## Remove Paint Before Welding or Heating

Avoid potentially toxic fumes and dust. Hazardous fumes can be generated when paint is heated by welding, soldering, or using a torch. Do all work outside or in a well ventilated area. Dispose of paint and solvent properly. Remove paint before welding or heating: If you sand or grind paint, avoid breathing the dust. Wear an approved respirator. If you use solvent or paint stripper, remove stripper with soap and water before welding. Remove solvent or paint stripper containers and other flammable material from area. Allow fumes to disperse at least 15 minutes before welding or heating.

## Service Tires Safely

MIF

Explosive separation of a tire and rim parts can cause serious injury or death.

Do not attempt to mount a tire unless you have the proper equipment and experience to perform the job.

Always maintain the correct tire pressure. Do not inflate the tires above the recommended pressure. Never weld or heat a wheel and tire assembly. The heat can cause an increase in air pressure resulting in a tire explosion. Welding can

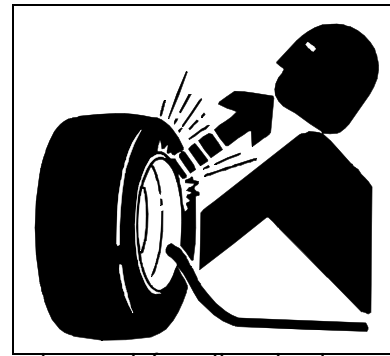

structurally weaken or deform the wheel.

When inflating tires, use a clip-on chuck and extension hose long enough to allow you to stand to one side and not in front of or over the tire assembly. Use a safety cage if available.

Check wheels for low pressure, cuts, bubbles, damaged rims or missing lug bolts and nuts.

## Handle Chemical Products Safely

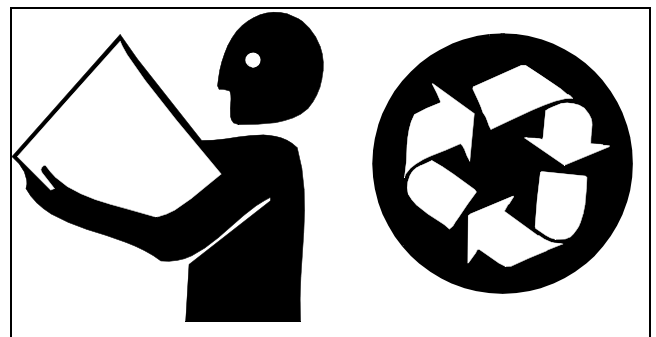

MIF

Direct exposure to hazardous chemicals can cause serious injury. Potentially hazardous chemicals used with John Deere equipment include such items as lubricants, coolants, paints, and adhesives.

A Material Safety Data Sheet (MSDS) provides specific details on chemical products: physical and health hazards, safety procedures, and emergency response techniques. Check the MSDS before you start any job using a hazardous chemical. That way you will know exactly what the risks are and how to do the job safely. Then follow procedures and recommended equipment.

It is best to wear full cover clothing and always wear protective goggles and rubber gloves to protect yourself while handling chemicals or using sprayer unit.

Prohibit all smoking, drinking and eating food in chemical-handling area.

Decontaminate all spraying equipment before servicing. Decontamination should be done in a safe area by washing with water, neutralization, or by means recommended by the manufacturer of the chemical last used.

# SAFETY

---

Spray solutions or vapors may be extremely dangerous. Treat all spray chemicals, solutions, or solution residues with great caution. Don't take chances. When in doubt, proceed as though contamination is present.

Keep spray material from contacting your skin. If spray material contacts skin, wash off immediately with clean water and detergent or follow the instructions of manufacturer of chemical last used.

## Dispose Of Waste Properly

Improperly disposing of waste can threaten the environment and ecology. Potentially harmful waste used with John Deere equipment include such items as oil, fuel, coolant, brake fluid, filters, and batteries. Use leakproof containers when draining fluids. Do not use food or beverage containers that may mislead someone into drinking from them. Do not pour waste onto the ground, down a drain, or into any water source. Inquire on the proper way to recycle or dispose of waste from your local environmental or recycling center, or from your John Deere dealer.

## Live With Safety



MIF

Before returning machine to customer, make sure machine is functioning properly, especially the safety systems. Install all guards and shields.

# SAFETY

---

---



# SPECIFICATIONS AND INFORMATION TABLE OF CONTENTS

---

---

## Table of Contents

<b>General Specifications .....</b>	<b>9</b>
Metric Fastener Torque Values .....	9
Metric Fastener Torque Values - Grade 7....	10
Inch Fastener Torque Values .....	11
<b>O-Ring Seal Service Recommendations .....</b>	<b>12</b>
Face Seal Fittings with Inch Stud Ends Torque .....	12
Face Seal Fittings with Metric Stud Ends Torque .....	13
O-Ring Face Seal Fittings .....	14
O-Ring Boss Fittings .....	14
<b>Oil and Lubricant Specifications .....</b>	<b>15</b>
Hydraulic Oil .....	15
Anti-Corrosion Grease.....	15
Alternative Lubricants.....	15
Synthetic Lubricants .....	16
Lubricant Storage .....	16
Mixing of Lubricants .....	16
<b>Serial Number Locations .....</b>	<b>16</b>
Machine Identification Number.....	16

# SPECIFICATIONS AND INFORMATION TABLE OF CONTENTS

---



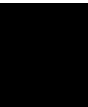

















---



# SPECIFICATIONS AND INFORMATION GENERAL SPECIFICATIONS

## General Specifications

### Metric Fastener Torque Values

Property Class and Head Markings	4.8		8.8		9.8		10.9		12.9	
										
Property Class and Nut Markings	5		10		10		10		12	
										

SIZE	Class 4.8		Class 8.8 or 9.8				Class 10.9				Class 12.9					
	Lubricated <sup>a</sup>		Dry <sup>a</sup>		Lubricated <sup>a</sup>		Dry <sup>a</sup>		Lubricated <sup>a</sup>		Dry <sup>a</sup>		Lubricated <sup>a</sup>		Dry <sup>a</sup>	
	N•m	lb-ft	N•m	lb-ft	N•m	lb-ft	N•m	lb-ft	N•m	lb-ft	N•m	lb-ft	N•m	lb-ft	N•m	lb-ft
M6	4.8	3.5	6	4.5	9	6.5	11	8.5	13	9.5	17	12	15	11.5	19	14.5
M8	12	8.5	15	11	22	16	28	20	32	24	40	30	37	28	47	35
M10	23	17	29	21	43	32	55	40	63	47	80	60	75	55	95	70
M12	40	29	50	37	75	55	95	70	110	80	140	105	130	95	165	120
M14	63	47	80	60	120	88	150	110	175	130	225	165	205	150	260	190
M16	100	73	125	92	190	140	240	175	275	200	350	225	320	240	400	300
M18	135	100	175	125	260	195	330	250	375	275	475	350	440	325	560	410
M20	190	140	240	180	375	275	475	350	530	400	675	500	625	460	800	580
M22	260	190	330	250	510	375	650	475	725	540	925	675	850	625	1075	800
M24	330	250	425	310	650	475	825	600	925	675	1150	850	1075	800	1350	1000
M27	490	360	625	450	950	700	1200	875	1350	1000	1700	1250	1600	1150	2000	1500
M30	675	490	850	625	1300	950	1650	1200	1850	1350	2300	1700	2150	1600	2700	2000
M33	900	675	1150	850	1750	1300	2200	1650	2500	1850	3150	2350	2900	2150	3700	2750
M36	1150	850	1450	1075	2250	1650	2850	2100	3200	2350	4050	3000	3750	2750	4750	3500

- Do not use these hand torque values if a different torque value or tightening procedure is given for a specific application. Torque values listed are for general use only and include a  $\pm 10\%$  variance factor. Check tightness of fasteners periodically. Do not use air powered wrenches.
- Shear bolts are designed to fail under predetermined loads. Always replace shear bolts with identical grade.
- Fasteners should be replaced with the same class. Make sure fastener threads are clean and that you properly start thread engagement. This will prevent them from failing when tightening.
- When bolt and nut combination fasteners are used,

torque values should be applied to the nut instead of the bolt head.

- Tighten toothed or serrated-type lock nuts to the full torque value.

<sup>a</sup> A “Lubricated” means coated with a lubricant such as engine oil, or fasteners with phosphate and oil coatings. “Dry” means plain or zinc plated (yellow dichromate - Specification JDS117) without any lubrication.

Reference: JDS-200

# SPECIFICATIONS AND INFORMATION GENERAL SPECIFICATIONS

---







---

## Metric Fastener Torque Values - Grade 7

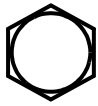
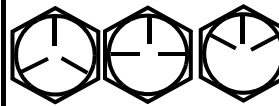
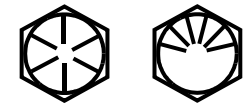
Size	Steel or Gray Iron Torque	Aluminum Torque
	N•m (lb-ft)	N•m (lb-ft)
M6	11 (8)	8 (6)
M8	24 (18)	19 (14)
M10	52 (38)	41 (30)
M12	88 (65)	70 (52)
M14	138 (102)	111 (82)
M16	224 (165)	179 (132)

# SPECIFICATIONS AND INFORMATION GENERAL SPECIFICATIONS

## Inch Fastener Torque Values

<b>SAE Grade and Head Markings</b>	1 or 2 <sup>b</sup> No Marks 	5    5.1    5.2 	8    8.2 
<b>SAE Grade and Nut Markings</b>	2 No Marks 	5  	8  

SIZE	Grade 1		Grade 2 <sup>b</sup>				Grade 5, 5.1 or 5.2				Grade 8 or 8.2					
	Lubricated <sup>a</sup>		Dry <sup>a</sup>		Lubricated <sup>a</sup>		Dry <sup>a</sup>		Lubricated <sup>a</sup>		Dry <sup>a</sup>		Lubricated <sup>a</sup>		Dry <sup>a</sup>	
	N•m	lb-ft	N•m	lb-ft	N•m	lb-ft	N•m	lb-ft	N•m	lb-ft	N•m	lb-ft	N•m	lb-ft	N•m	lb-ft
1/4	3.7	2.8	4.7	3.5	6	4.5	7.5	5.5	9.5	7	12	9	13.5	10	17	12.5
5/16	7.7	5.5	10	7	12	9	15	11	20	15	25	18	28	21	35	26
3/8	14	10	17	13	22	16	27	20	35	26	44	33	50	36	63	46
7/16	22	16	28	20	35	26	44	32	55	41	70	52	80	58	100	75
1/2	33	25	42	31	53	39	67	50	85	63	110	80	120	90	150	115
9/16	48	36	60	45	75	56	95	70	125	90	155	115	175	130	225	160
5/8	67	50	85	62	105	78	135	100	170	125	215	160	215	160	300	225
3/4	120	87	150	110	190	140	240	175	300	225	375	280	425	310	550	400
7/8	190	140	240	175	190	140	240	175	490	360	625	450	700	500	875	650
1	290	210	360	270	290	210	360	270	725	540	925	675	1050	750	1300	975
1-1/8	470	300	510	375	470	300	510	375	900	675	1150	850	1450	1075	1850	1350
1-1/4	570	425	725	530	570	425	725	530	1300	950	1650	1200	2050	1500	2600	1950
1-3/8	750	550	950	700	750	550	950	700	1700	1250	2150	1550	2700	2000	3400	2550
1-1/2	1000	725	1250	925	990	725	1250	930	2250	1650	2850	2100	3600	2650	4550	3350

- Do not use these hand torque values if a different torque value or tightening procedure is given for a specific application. Torque values listed are for general use only and include a ± 10% variance factor. Check tightness of fasteners periodically. Do not use air powered wrenches.
- Shear bolts are designed to fail under predetermined loads. Always replace shear bolts with identical grade.
- Fasteners should be replaced with the same class. Make sure fastener threads are clean and that you properly start thread engagement. This will prevent them from failing when tightening.
- When bolt and nut combination fasteners are used, torque values should be applied to the nut instead of the bolt head.

- Tighten toothed or serrated-type lock nuts to the full torque value.

<sup>a</sup> “**Lubricated**” means coated with a lubricant such as engine oil, or fasteners with phosphate and oil coatings. “**Dry**” means plain or zinc plated (yellow dichromate - Specification JDS117) without any lubrication.

<sup>b</sup> “**Grade 2**” applies for hex cap screws (not hex bolts) up to 152 mm (6 in.) long “**Grade 1**” applies for hex cap screws over 152 mm (6 in.) long, and for all other types of bolts and screws of any length.

Reference: JDS-G200

# SPECIFICATIONS AND INFORMATION O-RING SEAL SERVICE

## O-Ring Seal Service Recommendations

### Face Seal Fittings with Inch Stud Ends Torque

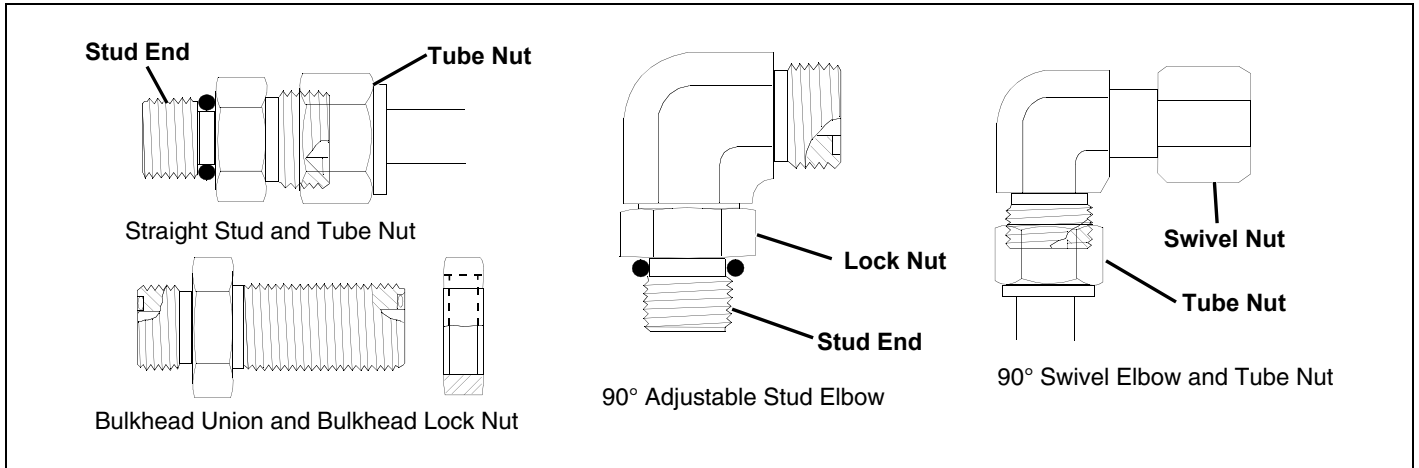

MIF

Nominal Tube OD/Hose ID				Face Seal Tube/Hose End					O-Ring Stud Ends		
Metric Tube OD	Inch Tube OD			Thread Size	Tube Nut/ Swivel Nut Torque		Bulkhead Lock Nut Torque		Thread Size	Straight Fitting or Lock Nut Torque	
mm	Dash Size	in.	mm	in.	N•m	lb-ft	N•m	lb-ft	in.	N•m	lb-ft
	-3	0.188	4.76						3/8-24	8	6
6	-4	0.250	6.35	9/16-18	16	12	12	9	7/16-20	12	9
8	-5	0.312	7.94						1/2-20	16	12
10	-6	0.375	9.52	11/16-16	24	18	24	18	9/16-18	24	18
12	-8	0.500	12.70	13/16-16	50	37	46	34	3/4-16	46	34
16	-10	0.625	15.88	1-14	69	51	62	46	7/8-14	62	46
	-12	0.750	19.05	1-3/16-12	102	75	102	75	1-1/16-12	102	75
22	-14	0.875	22.22	1-3/16-12	102	75	102	75	1-3/16-12	122	90
25	-16	1.000	25.40	1-7/16-12	142	105	142	105	1-5/16-12	142	105
32	-20	1.25	31.75	1-11/16-12	190	140	190	140	1-5/8-12	190	140
38	-24	1.50	38.10	2-12	217	160	217	160	1-7/8-12	217	160

**NOTE: Torque tolerance is +15%, -20%**

# SPECIFICATIONS AND INFORMATION O-RING SEAL SERVICE

## Face Seal Fittings with Metric Stud Ends Torque

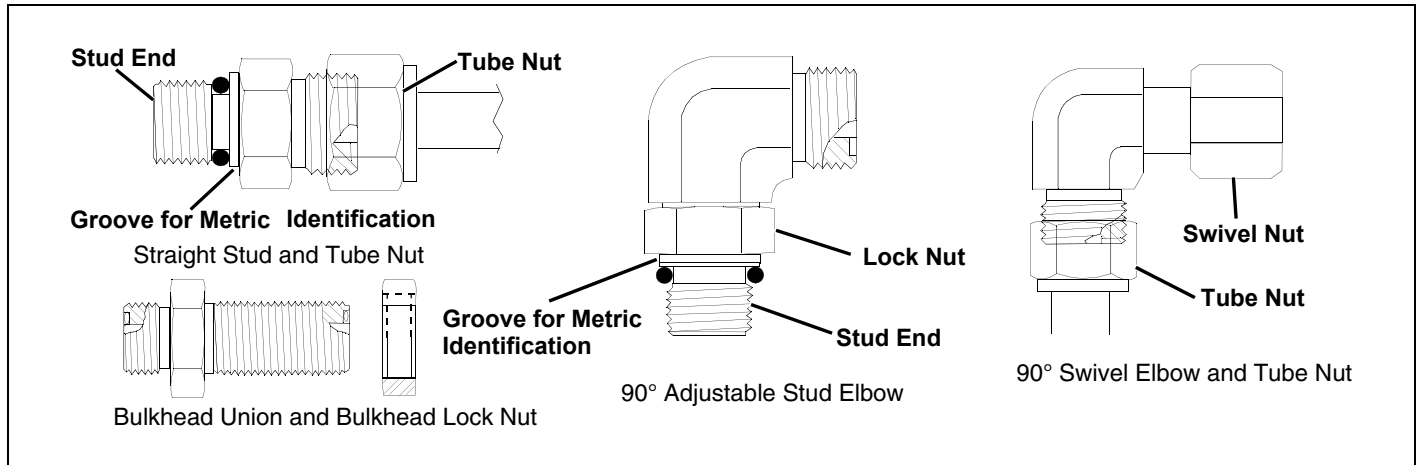

MIF

Nominal Tube OD/Hose ID				Face Seal Tube/Hose End						O-Ring Stud Ends, Straight Fitting or Lock Nut					
Metric Tube OD	Inch Tube OD			Thread Size	Hex Size	Tube Nut/ Swivel Nut Torque		Bulkhead Lock Nut Torque		Thread Size	Hex Size	Steel or Gray Iron Torque		Aluminum Torque	
	mm	Das h Size	in.			mm	in.	mm	N•m			lb-ft	N•m	lb-ft	mm
6	-4	0.250	6.35	9/16-18	17	16	12	12	9	M12X1.5	17	21	15.5	9	6.6
8	-5	0.312	7.94												
										M14X1.5	19	33	24	15	11
10	-6	0.375	9.52	11/16-16	22	24	18	24	18	M16X1.5	22	41	30	18	13
12	-8	0.500	12.70	13/16-16	24	50	37	46	34	M18X1.5	24	50	37	21	15
16	-10	0.625	15.88	1-14	30	69	51	62	46	M22X1.5	27	69	51	28	21
	-12	0.750	19.05	1-3/16-12	36	102	75	102	75	M27X2	32	102	75	46	34
22	-14	0.875	22.22	1-3/16-12	36	102	75	102	75	M30X2	36				
25	-16	1.000	25.40	1-7/16-12	41	142	105	142	105	M33X2	41	158	116	71	52
28										M38X2	46	176	130	79	58
32	-20	1.25	31.75	1-11/16-12	50	190	140	190	140	M42X2	50	190	140	85	63
38	-24	1.50	38.10	2-12	60	217	160	217	160	M48X2	55	217	160	98	72

**NOTE: Torque tolerance is +15%, -20%**

# SPECIFICATIONS AND INFORMATION O-RING SEAL SERVICE

## O-Ring Face Seal Fittings

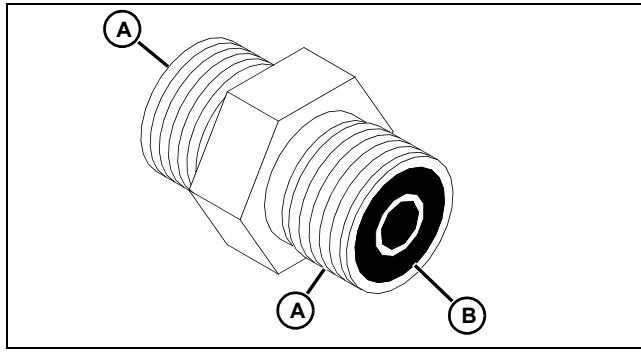

1. Inspect the fitting sealing surfaces (A). They must be free of dirt or defects.
2. Inspect the O-ring (B). It must be free of damage or defects.
3. Lubricate O-rings and install into groove using petroleum jelly to hold in place.
4. Push O-ring into the groove with plenty of petroleum jelly so O-ring is not displaced during assembly.
5. Index angle fittings and tighten by hand-pressing joint together to ensure O-ring remains in place.

**IMPORTANT: Avoid damage! Do not allow hoses to twist when tightening fittings. Use two wrenches to tighten hose connections; one to hold the hose, and the other to tighten the swivel fitting.**

6. Tighten fitting or nut to torque value shown on the chart per dash size stamped on the fitting.

## O-Ring Boss Fittings

1. Inspect boss O-ring boss seat. It must be free of dirt and defects. If repeated leaks occur, inspect for defects with a magnifying glass. Some raised defects can be removed with a slip stone.

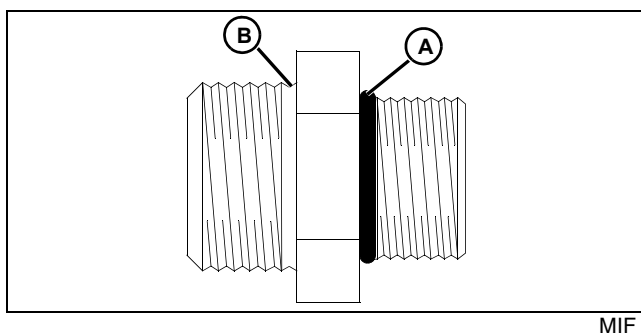

2. Put hydraulic oil or petroleum jelly on the O-ring (A). Place electrical tape over the threads to protect O-ring from nicks. Slide O-ring over the tape and into the groove (B) of fitting. Remove tape.

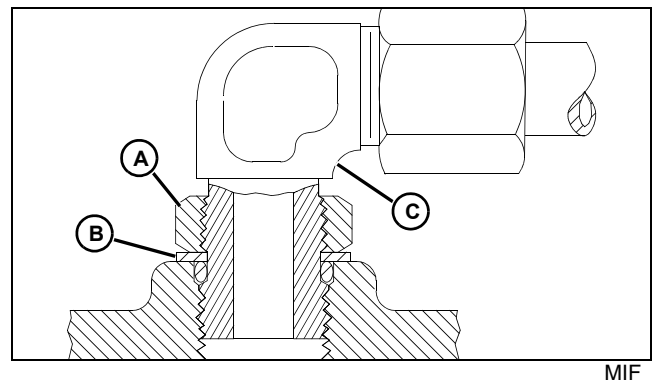

3. For angle fittings, loosen special nut (A) and push special washer (B) against threads so O-ring can be installed into the groove of fitting.
4. Turn fitting into the boss by hand until special washer or washer face (straight fitting) contacts boss face and O-ring is squeezed into its seat.
5. To position angle fittings (C), turn the fitting counter-clockwise a maximum of one turn.
6. Tighten straight fittings to torque value shown on chart. For angle fittings, tighten the special nut to value shown in the chart while holding body of fitting with a wrench.

Thread Size	Torque <sup>a</sup>		Number of Flats <sup>b</sup>
	N•m	lb-ft	
3/8-24 UNF	8	6	2
7/16-20 UNF	12	9	2
1/2-20 UNF	16	12	2
9/16-18 UNF	24	18	2
3/4-16 UNF	46	34	2
7/8-14 UNF	62	46	1-1/2
1-1/16-12 UN	102	75	1
1-3/16-12 UN	122	90	1
1-5/16-12 UN	142	105	3/4
1-5/8-12 UN	190	140	3/4
1-7/8-12 UN	217	160	1/2

<sup>a</sup>Torque tolerance is  $\pm 10$  percent.

<sup>b</sup>To be used if a torque wrench cannot be used. After tightening fitting by hand, put a mark on nut or boss; then tighten special nut or straight fitting the number of flats shown.

# SPECIFICATIONS AND INFORMATION OIL AND LUBRICANT

## Oil and Lubricant Specifications

### Hydraulic Oil

Use the appropriate oil viscosity based on these air temperature ranges. Operating outside of these recommended oil air temperature ranges may cause premature hydrostatic transmission or hydraulic system failures.

**IMPORTANT: Avoid damage! Mixing of LOW VISCOSITY HY - GARD® and HY - GARD® oils is permitted. DO NOT mix any other oils in this transmission. DO NOT use engine oil or "Type F" (Red) Automatic Transmission Fluid.**

The following John Deere transmission and hydraulic oil is **PREFERRED**:

- **LOW VISCOSITY HY - GARD® - JDM J20D.**

The following John Deere oil is also recommended if above preferred oil is not available:

- **HY - GARD® - JDM J20C.**

Other oils may be used if above recommended John Deere oils are not available, provided they meet one of the following specifications:

- John Deere Standard JDM J20D;
- John Deere Standard JDM J20C.

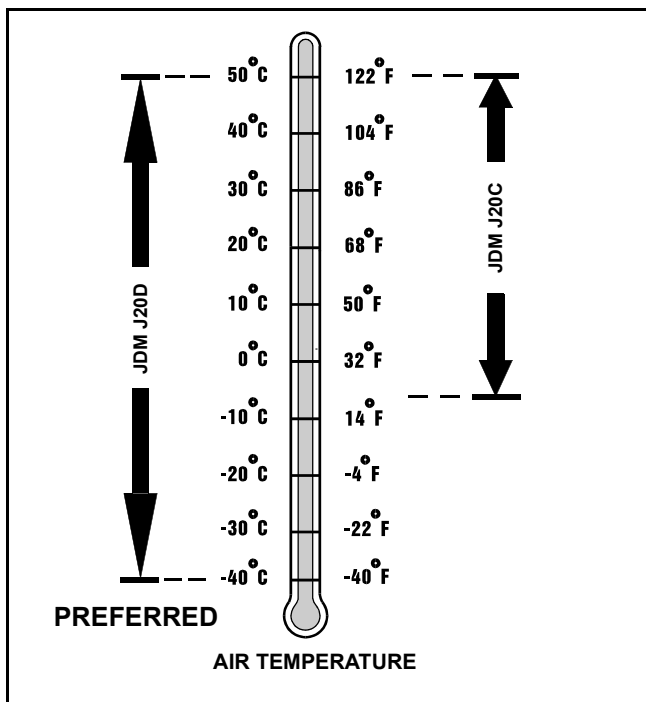

MIF

### Anti-Corrosion Grease

This anti-corrosion grease is formulated to provide the best protection against absorbing moisture, which is one of the major causes of corrosion. This grease is also superior in its resistance to separation and migration.

The following anti-corrosion grease is **preferred**:

- **MOLY HIGH-TEMPERATURE EP GREASE® - JDM J25C, NLGI Grade 2**
- **HIGH-TEMPERATURE EP GREASE® - JDM J13E4, NLGI Grade 2**
- **GREASE-GARD™ - JDM J25C, NLGI Grade 2**

Other greases may be used if they meet or exceed the following specification:

- John Deere Standard JDM J13A2, NLGI Grade 1.

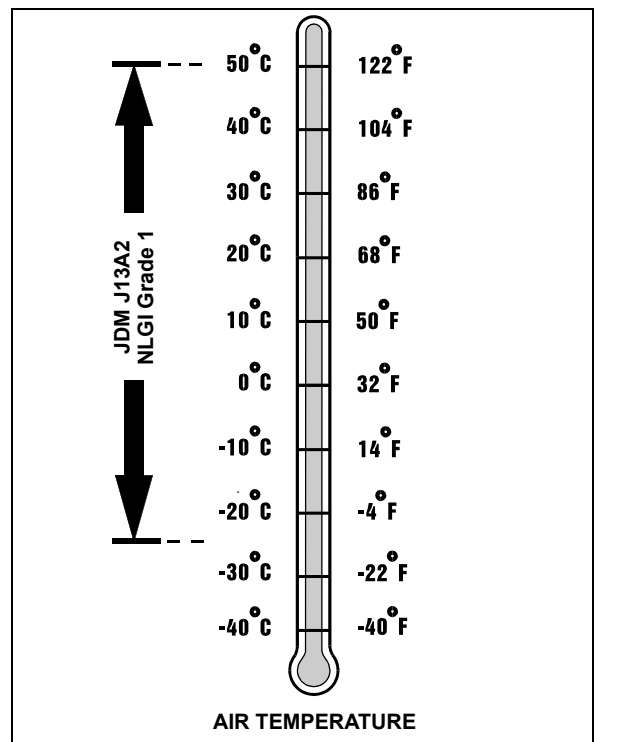

MIF

### Alternative Lubricants

Use of alternative lubricants could cause reduced life of the component.

If alternative lubricants are to be used, it is recommended that the factory fill be thoroughly removed before switching to any alternative lubricant.

# SPECIFICATIONS AND INFORMATION SERIAL NUMBER LOCATIONS

---

## Synthetic Lubricants

Synthetic lubricants may be used in John Deere equipment if they meet the applicable performance requirements (industry classification and/or military specification) as shown in this manual.

The recommended air temperature limits and service or lubricant change intervals should be maintained as shown in the operator's manual, unless otherwise stated on lubricant label.

Avoid mixing different brands, grades, or types of oil. Oil manufacturers blend additives in their oils to meet certain specifications and performance requirements. Mixing different oils can interfere with the proper functioning of these additives and degrade lubricant performance.

## Lubricant Storage

All machines operate at top efficiency only when clean lubricants are used. Use clean storage containers to handle all lubricants. Store them in an area protected from dust, moisture, and other contamination. Store drums on their sides. Make sure all containers are properly marked as to their contents. Dispose of all old, used containers and their contents properly.

## Mixing of Lubricants

In general, avoid mixing different brands or types of lubricants. Manufacturers blend additives in their lubricants to meet certain specifications and performance requirements. Mixing different lubricants can interfere with the proper functioning of these additives and lubricant properties which will downgrade their intended specified performance.

## Serial Number Locations

### Machine Identification Number

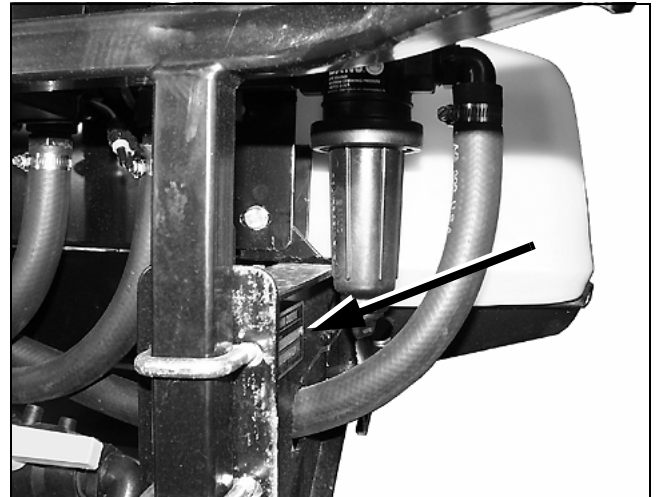

MX0723

#### Picture Note: HD200 Sprayer Shown

The machine identification number is located on the rear frame plate.

# ELECTRICAL TABLE OF CONTENTS

<b>Table of Contents</b>	<b>Diagnostics and Operation</b> .....	<b>44</b>
	Power Circuit Operation (All Models).....	44
	Power Circuit Schematic.....	45
	Power Circuit Diagnosis.....	46
	Pressure Regulator Valve Operation .....	50
	Pressure Regulator Valve Circuit Schematic HD200 (SN -035000) .....	51
	Pressure Regulator Valve Circuit Schematic HD200 (SN 035001-) and HD300.....	52
	Pressure Regulator Valve Circuit Diagnosis	53
	Boom Regulator Valve Circuit Operation HD200 (SN -35000) .....	55
	Boom Regulator Valve Circuit Operation HD200 (SN 35001-) and HD300.....	55
	Boom Regulator Valve Circuit Schematic HD200 (SN -035000) .....	56
	Boom Regulator Valve Circuit Schematic HD200 (SN 035001-) and HD300.....	57
	Boom Regulator Valve Circuit Diagnosis.....	58
	Boom Actuator Circuit Operation .....	61
	Boom Actuator Circuit Schematic HD200 (SN -035000) .....	62
	Boom Actuator Circuit Schematic HD200 (SN 035001-) and HD300 .....	63
	Boom Actuator Circuit Diagnosis .....	64
	Boom Actuator Circuit Diagnosis Continued HD200 (SN -035000) .....	64
	Boom Actuator Circuit Diagnosis Continued HD200 (SN 035001-) and HD300.....	66
	Foam Marker Circuit Operation .....	68
	Foam Marker Circuit Schematic .....	69
	Foam Marker Circuit Diagnosis .....	70
	Electric Hose Reel - Rewind Circuit Operation .....	72
	Electric Hose Reel Circuit Schematic .....	72
	Electric Hose Reel Circuit Diagnosis .....	73
	Handgun (Option) Circuit Operation .....	74
	Handgun/Autorate Controller Circuit Schematic .....	75
	<b>Tests and Adjustments</b> .....	<b>76</b>
	Fuse Test.....	76
	Circuit Breaker Test.....	76
	Hose Reel Solenoid Test.....	77
	Hose Reel Switch Test .....	77
	Relay Test.....	77
	S.P.S.T. Switch Test.....	78
	S.P.D.T. Switch Test.....	79
	D.P.D.T. Switch Test .....	79
<b>General Information</b> .....	<b>19</b>	
Reading Electrical Schematics.....	19	
Theory Of Operation Information.....	20	
Diagnostic Information.....	20	
Wire Color Abbreviation Chart.....	20	
Common Circuit Tests.....	21	
Conductors For 12 Volt Circuits .....	21	
<b>Specifications</b> .....	<b>22</b>	
General Specifications .....	22	
Torques Specifications .....	22	
<b>Component Location</b> .....	<b>23</b>	
Electrical Components - HD200 (SN -035000).....	23	
Electrical Components - HD200 (SN 035001-) and HD300.....	24	
Control Panel Components - HD200 (SN -035000).....	25	
Control Panel Components - HD200 (SN 035001-) and HD300.....	26	
<b>Schematics and Harnesses</b> .....	<b>27</b>	
Electrical Schematic and Wiring Harness Leg- end .....	27	
Electrical Schematic HD200 (SN -035000) ..	29	
Electrical Schematic HD200 (SN -035000) ..	30	
Electrical Schematic HD200 (SN -035000) ...	31	
Electrical Wiring Harness HD200 (SN -035000).....	32	
Electrical Wiring Harness HD200 (SN -035000).....	33	
Wire Color Codes HD200 (SN -035000) .....	34	
Electrical Schematic HD200 (SN 035001-) and HD300.....	36	
Electrical Schematic HD200 (SN 035001-) and HD300.....	37	
Electrical Schematic HD200 (SN 035001-) and HD300.....	38	
Electrical Front Wiring Harness HD200 (SN 035001-) and HD300.....	39	
Electrical Front Wiring Harness HD200 (SN 035001-) and HD300.....	40	
Electrical Rear Wiring Harness HD200 (SN 035001-) and HD300.....	41	
Wire Color Codes HD200 (SN 035001-) and HD300.....	42	

# ELECTRICAL TABLE OF CONTENTS

---

---

Boom Actuator Motor Amperage Draw Test	80
<b>Repair</b> .....	<b>80</b>
Replace Actuator Clutch.....	80
Replace Motor .....	80
Cover Tube Seal .....	81

# ELECTRICAL GENERAL INFORMATION

## General Information

### Reading Electrical Schematics

The schematic is made up of individual circuits laid out in a sequence of related functions. It is formatted with all power wires (A) across the top and all ground wires (B) across the bottom. Current flow is generally from top to bottom through each circuit and component. All components are shown in the off position. The diagram does not list connector (C) information unless needed to avoid confusion. If the connector is shown, the number next to it is the terminal pin location (D) in the connector.

Each component is shown by a symbol (E), its name (F), and an identification code (G). The identification code

contains a device identifying letter (H) and number (I).

The identifying letter is always the same for a specific component, but the identifying numbers are numbered consecutively from upper left to lower right. The terminal designation (J) is placed directly outside the symbol next to the connecting wire path. Switch positions (K) are also placed directly outside the symbol. The solid line (L) shows the position the switch is currently in and dash lines (M) represent other switch positions.

Each circuit is identified at the bottom of the drawing by a section number (N) and section name (O).

The circuit number (P) and wire color (Q) of the wires are shown directly next to the wire path.

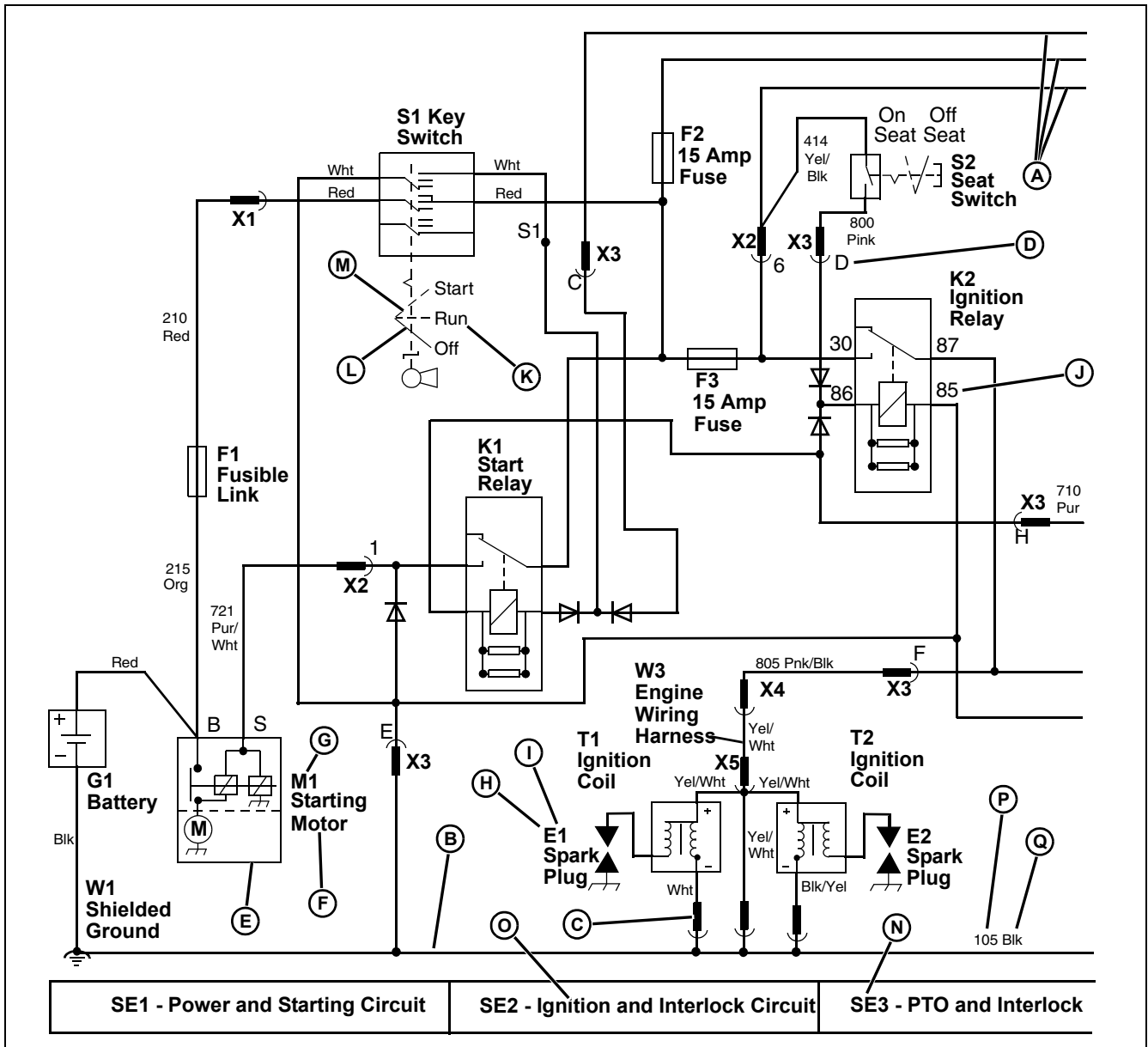

MIF

# ELECTRICAL GENERAL INFORMATION

The same component name and identification code are used consistently on all diagrams in this section. Components can be easily cross-referenced.

## Theory Of Operation Information

The theory of operation stories divide the electrical system into individual circuits by function. Each circuit is isolated from the main wiring schematic and only shows the components that are used in it. The story contains information on function, operating conditions, and theory of operation. The circuit schematics are drawn with the components in the operating position, with the power, or battery positive, into them across the top and the ground, or battery negative, across the bottom.

## Diagnostic Information

The diagnostic procedure is used to test the complete circuit regardless of the problem or complaint. Select a symptom or system from the quick check or troubleshooting chart and follow the test procedures under that heading.

The diagnostic procedure lists:

- Test conditions
- Test sequence
- Test location
- Normal reading
- Check or test to perform if reading is not normal

When performing the test or check, be sure to set your machine up to the TEST POINT/PROCEDURES listed in the first column and follow the sequence carefully. The middle RESULTS column gives the reading or condition that should be obtained in **BOLD** print. If the results of the test or check are not normal, perform the test, check, or adjustment listed below the **BOLD** print. The system diagram that accompanies each test procedure is drawn to resemble machine components. The leader line points to the exact point the test is to be made.

## Wire Color Abbreviation Chart

Blk	Black
Blu	Blue
Brn	Brown
Grn	Green
Gry	Gray
Org	Orange
Pnk	Pink
Pur	Purple
Red	Red
Tan	Tan
Wht	White
Yel	Yellow
Blk/Wht	Black/White
Blu/Wht	Blue/White
Brn/Wht	Brown/White
Brn/Yel	Brown/Yellow
Dk Blu	Dark Blue
Dk Brn/Lt Grn	Dark Brown/Light Green
Dk Brn/Red	Dark Brown/Red
Dk Brn/Yel	Dark Brown/Yellow
Dk Grn	Dark Green
Lt Blue	Light Blue
Lt Grn	Light Green
Org/Wht	Orange/White
Pnk/Blk	Pink/Black
Pur/Wht	Purple/White
Red/Blk	Red/Black
Red/Wht	Red/White
Wht/Blk	White/Black
Wht/Red	White/Red
Yel/Blk	Yellow/Black
Yel/Red	Yellow/Red
Yel/Wht	Yellow/White

# ELECTRICAL GENERAL INFORMATION

## Common Circuit Tests

M85601 MIF

### Shorted Circuit:

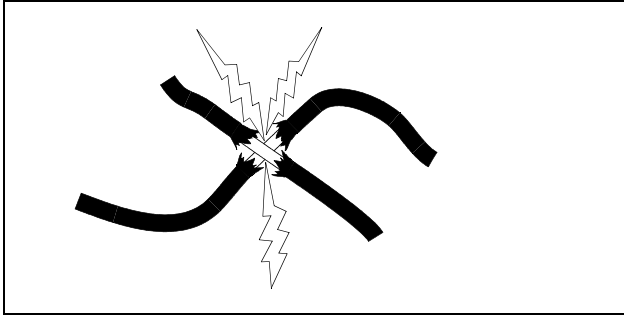

M85600 MIF

A shorted circuit may result in the wrong component operating (i.e. improper wire-to-wire contact). To test for a shorted or improperly wired circuit:

1. Turn component switch on.
2. Start at the controlling switch of the component that should not be operating.
3. Follow the circuit and disconnect wires at connectors until component stops operating.
4. Shorted or improper connections will be the last two wires disconnected.

### High Resistance or Open Circuit:

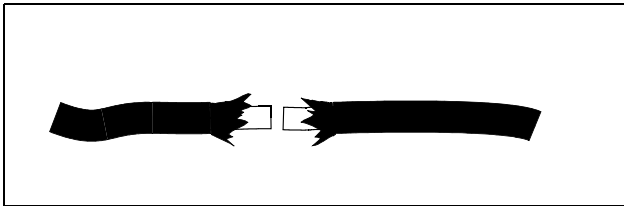

## Conductors For 12 Volt Circuits

Stranded Conductors For 12 Volt Circuits						
SAE Wire Size (Gauge)	20	18	16	14	12	10
Metric Wire Size (mm)	0.5	0.8	1.0	2.0	3.0	5.0
Typical Stranding	7 X 28	16 X 30	19 X 29	19 X 27	19 X 25	19 X 23
Minimum Conductor Area In Circular Mils	1072	1537	2336	3702	5833	9343

High resistance or open circuits usually result in slow, dim or no component operation (i.e. poor, corroded, or disconnected connections). Voltage at the component will be low when the component is in operation. To test for high resistance and open circuits:

1. Check all terminals and grounds of the circuit for corrosion.
2. If terminals are not corroded or loose, the problem is in the component or wiring.

### Grounded Circuit:

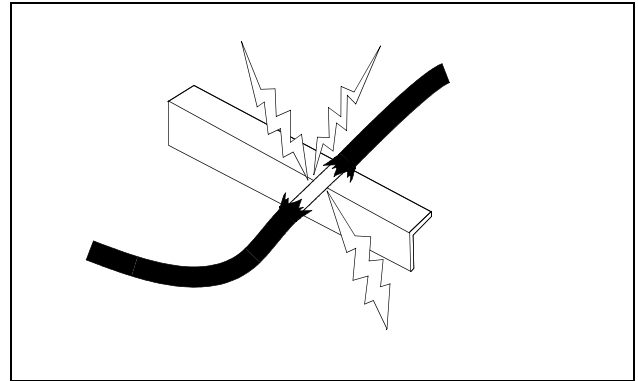

M85602 MIF

Grounded circuits usually result in no component operation or a blown fuse.

# ELECTRICAL SPECIFICATIONS

---

---

## Specifications

### General Specifications

Operating Voltage	12 VDC
Main Fuse	40-amp Circuit Breaker (Automatic-Reset)
Boom Valve Circuit Fuse	15 Amp
Boom Valve Fuse	Current Limiting Breaker (Re-settable)
Boom Actuator Fuse (SN -35000)	30 amp
Boom Actuator Fuse (SN 35001-)	20 amp
ARC/GPS Option Fuse	5 amp
Foam Marker Option Fuse	15 amp
Hose Reel Option Fuse (fuse or circuit breaker)	40-amp

### Torques Specifications

#### Boom Lift Actuator:

Gear Case Housing Cap Screws	8 N•m (70 lb-in.)
Gear Case Housing Screw	2.3 N•m (20 lb-in.)
Motor Mounting Nuts	8 N•m (70 lb-in.)

# ELECTRICAL COMPONENT LOCATION

## Component Location

### Electrical Components - HD200 (SN -035000)

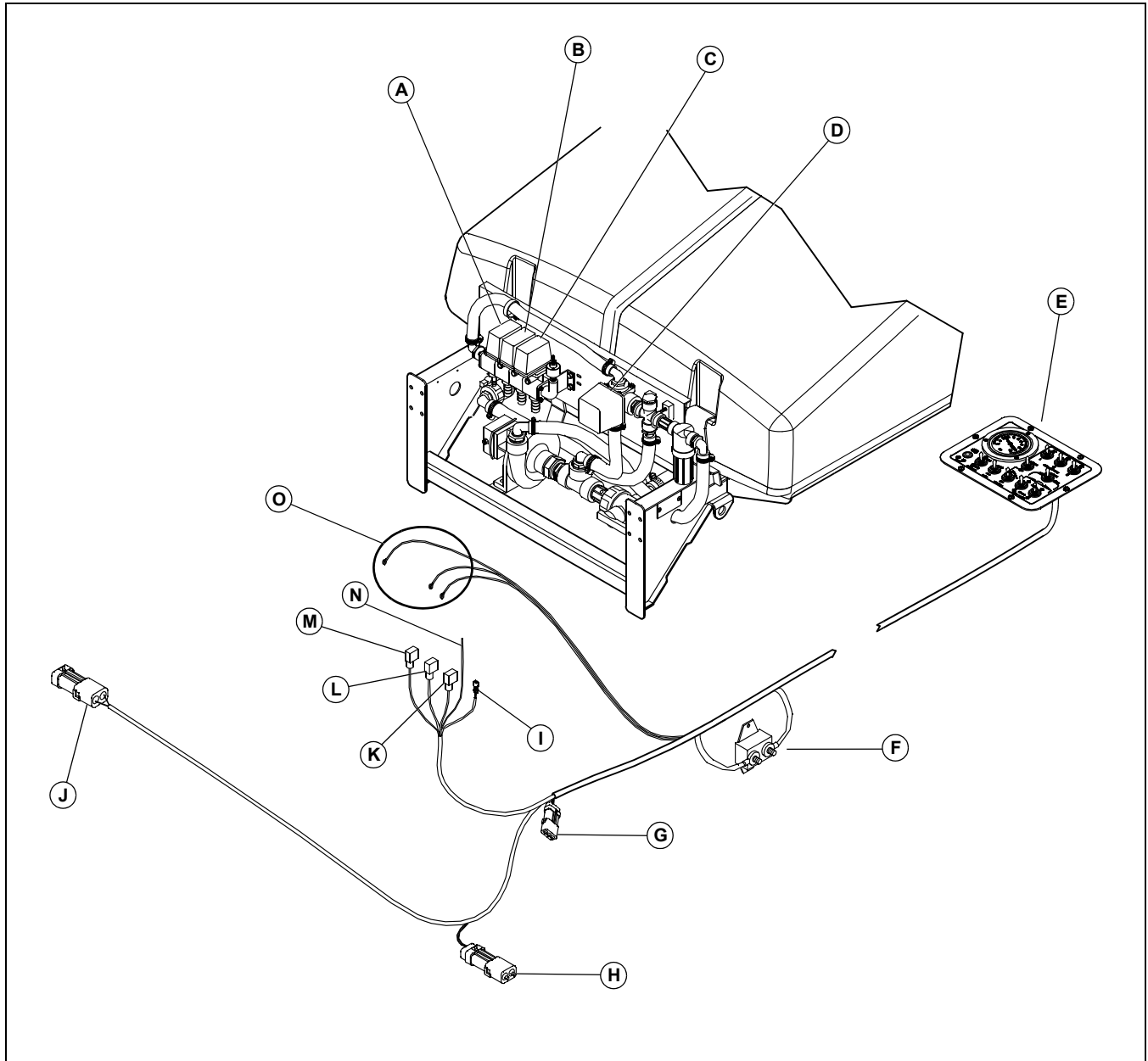

MIF

- |   |  |
|---|--|
| <b>A - Left Boom Regulator Valve</b>          | <b>K - X9 to Right Boom Regulator Valve</b>  |
| <b>B - Center Boom Regulator Valve</b>        | <b>L - X8 to Center Boom Regulator Valve</b> |
| <b>C - Right Boom Regulator Valve</b>         | <b>M - X7 to Left Boom Regulator Valve</b>   |
| <b>D - Pump Pressure Regulator</b>            | <b>N - Tubing</b>                            |
| <b>E - Control Panel</b>                      | <b>O - Battery Connections</b>               |
| <b>F - F1 Circuit Breaker 50 Amp</b>          |  |
| <b>G - X12 to X11</b>                         |  |
| <b>H - X5 to M2 Right Boom Actuator Motor</b> |  |
| <b>I - X2 to Pump Pressure Regulator</b>      |  |
| <b>J - X4 to M1 Left Boom Actuator</b>        |  |

# ELECTRICAL COMPONENT LOCATION

## Electrical Components - HD200 (SN 035001-) and HD300

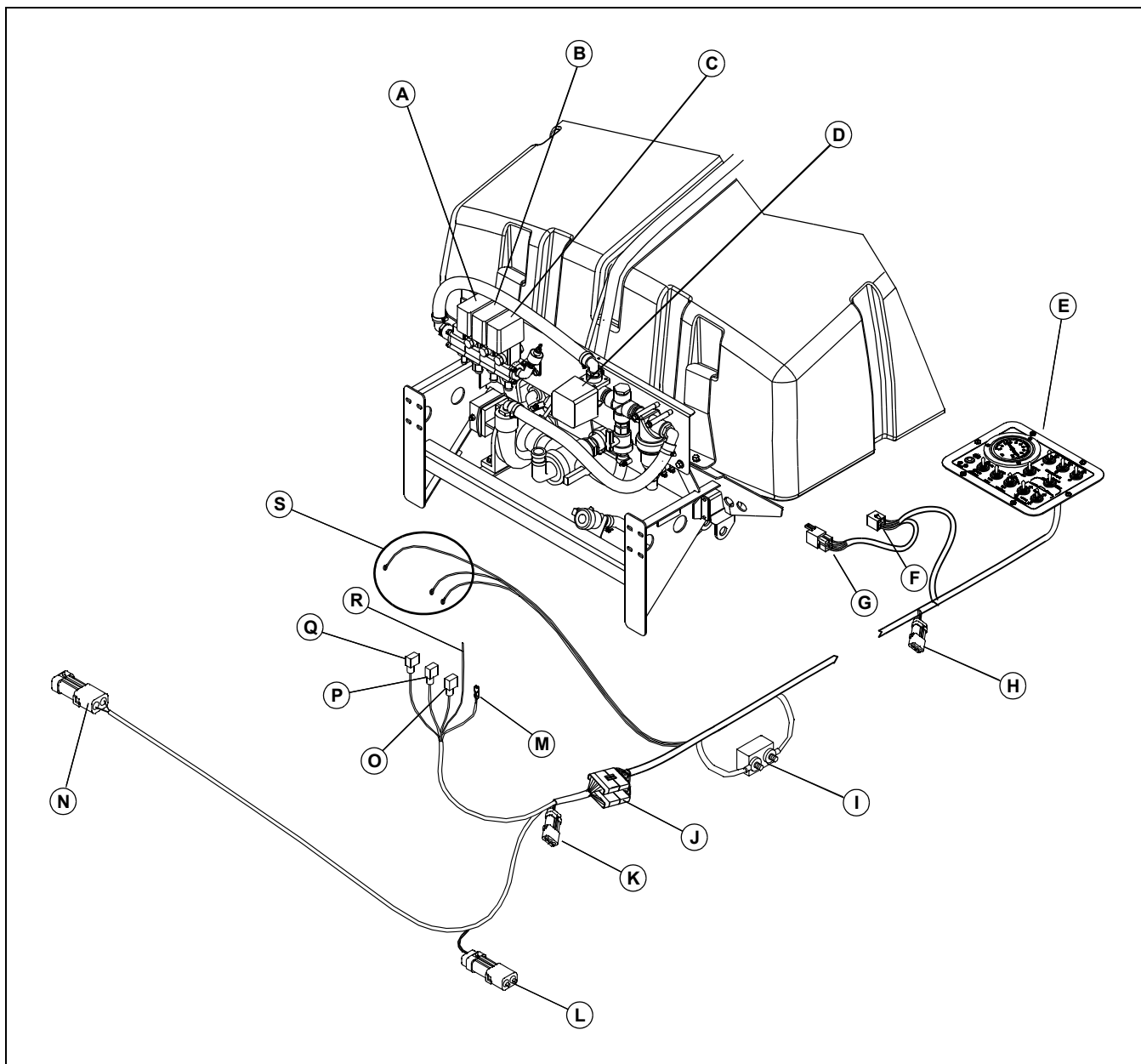

MIF

- |  |   |
|--|---|
| <b>A - Left Boom Regulator Valve</b>                           | <b>L - X5 to M2 Right Boom Actuator Motor</b> |
| <b>B - Center Boom Regulator Valve</b>                         | <b>M - X2 to Pump Pressure Regulator</b>      |
| <b>C - Right Boom Regulator Valve</b>                          | <b>N - X4 to M1 Left Boom Actuator</b>        |
| <b>D - Pump Pressure Regulator</b>                             | <b>O - X9 to Right Boom Regulator Valve</b>   |
| <b>E - Control Panel</b>                                       | <b>P - X8 to Center Boom Regulator Valve</b>  |
| <b>F - X19 PTO Connector</b>                                   | <b>Q - X7 to Left Boom Regulator Valve</b>    |
| <b>G - X20 PTO Connector</b>                                   | <b>R - Tubing</b>                             |
| <b>H - Hose Reel Connector</b>                                 | <b>S - Battery Connections</b>                |
| <b>I - F1 Circuit Breaker 40 Amp</b>                           |   |
| <b>J - X15 and X16 Front to Rear Wiring Harness Connectors</b> |   |
| <b>K - X12 to X11</b>  |   |

# ELECTRICAL COMPONENT LOCATION

## Control Panel Components - HD200 (SN -035000)

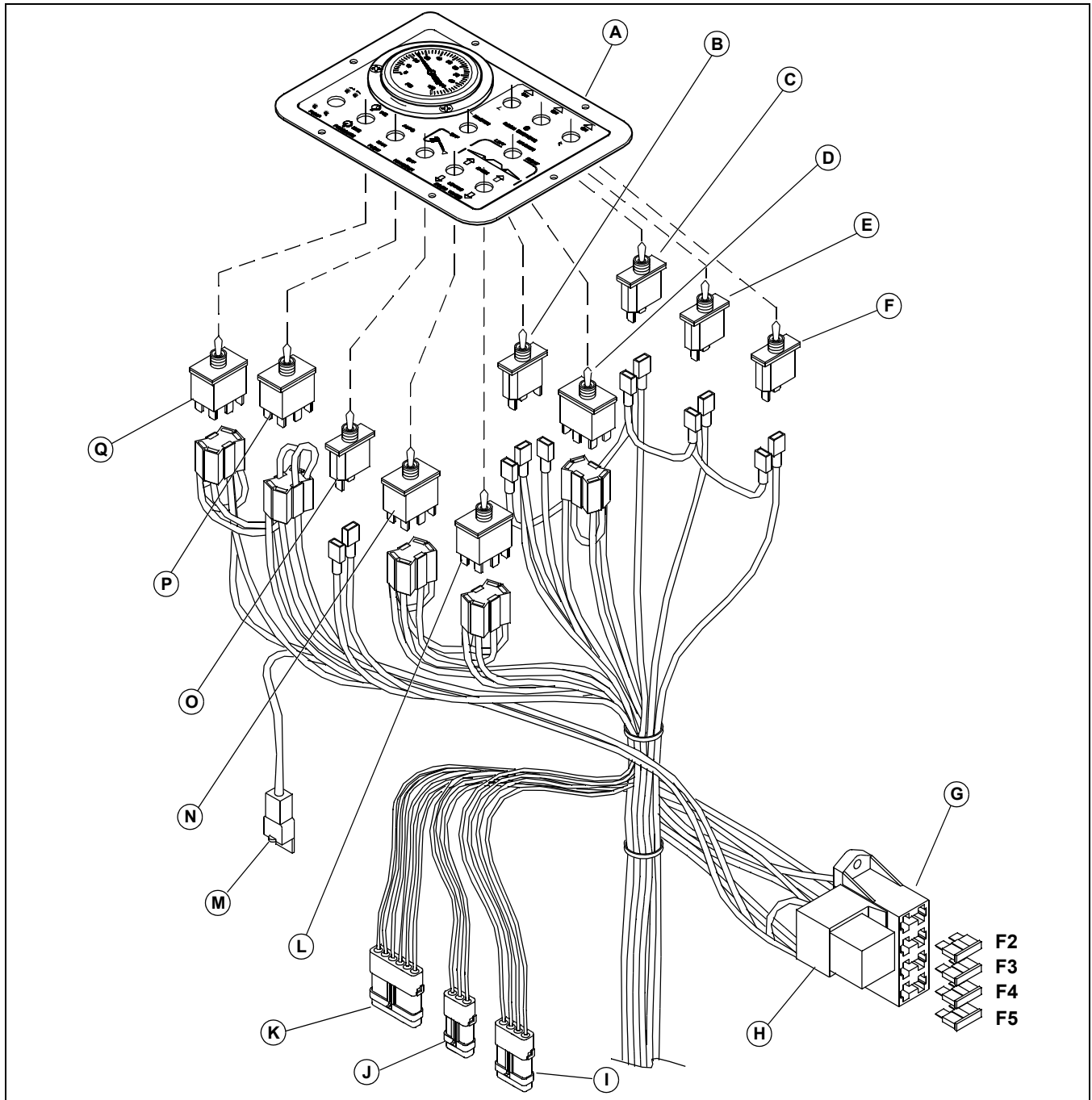

MIF

- |   |   |
|---|---|
| <b>A - Pressure Gauge</b>               | <b>J - X3 (Reserved - Optional Equipment)</b>         |
| <b>B - S6 Master Boom On/Off Switch</b> | <b>K - X11 to X12 (Reserved - Optional Equipment)</b> |
| <b>C - S7 Left Boom On/Off Switch</b>   | <b>L - S5 Right Boom Raise/Lower Switch</b>           |
| <b>D - S10 Foam Marker Switch</b>       | <b>M - S11 Handgun On/Off Switch</b>                  |
| <b>E - S8 Center Boom On/Off Switch</b> | <b>N - S4 Left Boom Raise/Lower Switch</b>            |
| <b>F - S9 Right Boom On/Off Switch</b>  | <b>O - S11 Handgun On/Off Switch</b>                  |
| <b>G - Fuse Block</b>                   | <b>P - S3 Flow Auto/Man Switch</b>                    |
| <b>H - K1 Main Disconnect Relay</b>     | <b>Q - S2 Pressure Inc/Off/Dec Switch</b>             |
| <b>I - X10 to Handgun (Option)</b>      |   |

# ELECTRICAL COMPONENT LOCATION

Product: John Deere ProGator HD200 and HD300 Sprayer Attachment Service Repair Technical Manual

Full Download: <https://www.bobmanualstore.com/downloads/john-deere-progator-hd200-and-hd300-sprayer-attachment-service-repair-technical-manual/>  
**Control Panel Components - HD200 (SN 035001-) and HD300**

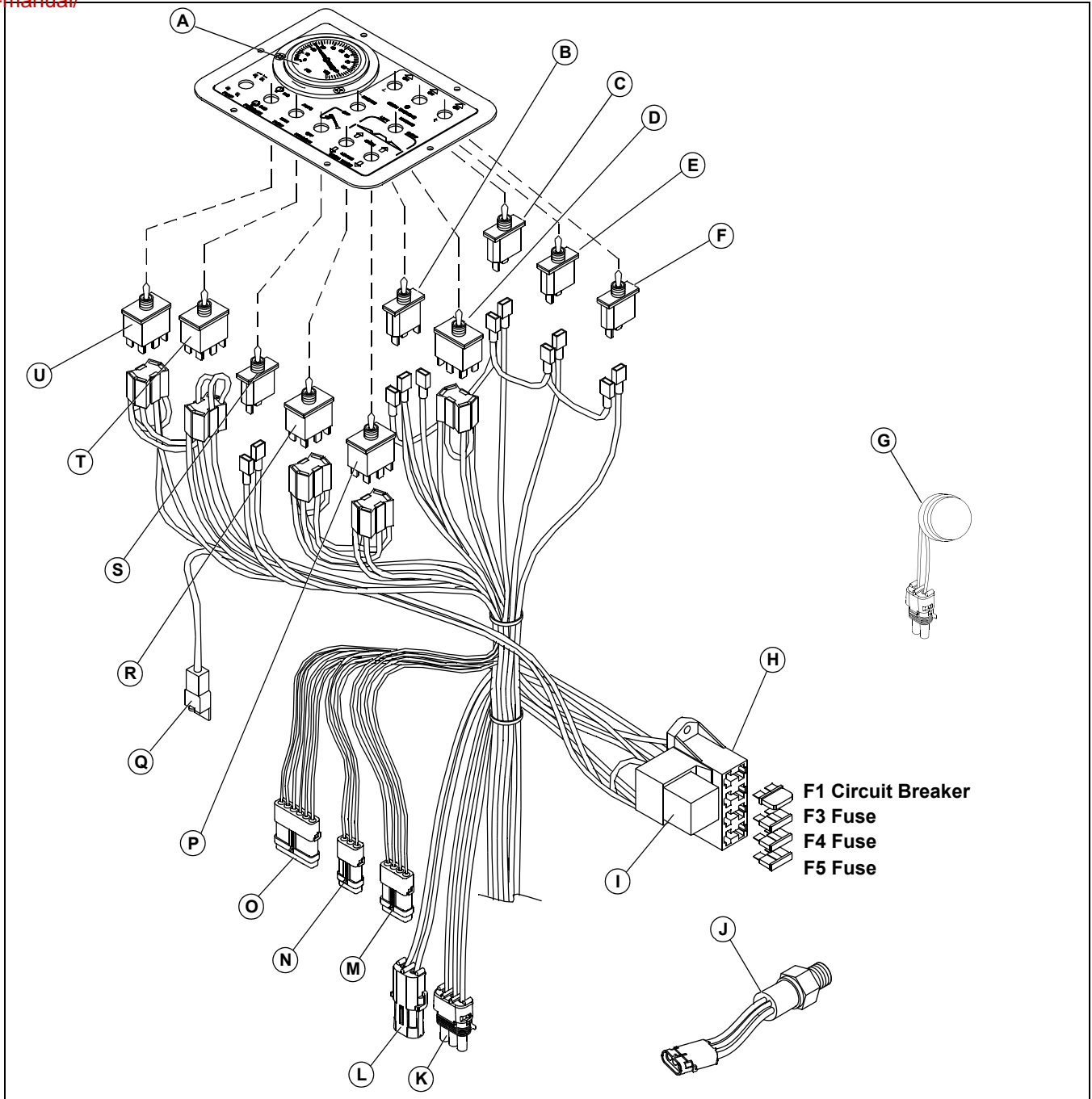

MIF

- |   |   |
|---|---|
| <b>A - Pressure Gauge</b>               | <b>J - B1 Pressure Sensor Switch</b>                  |
| <b>B - S6 Master Boom On/Off Switch</b> | <b>K - X18 to B1 Pressure Sensor Switch</b>           |
| <b>C - S7 Left Boom On/Off Switch</b>   | <b>L - X17 to H1 Buzzer</b>                           |
| <b>D - S10 Foam Marker Switch</b>       | <b>M - X10 to Handgun (Option)</b>                    |
| <b>E - S8 Center Boom On/Off Switch</b> | <b>N - X3 (Reserved - Optional Equipment)</b>         |
| <b>F - S9 Right Boom On/Off Switch</b>  | <b>O - X11 to X12 (Reserved - Optional Equipment)</b> |
| <b>G - H1 Low Pressure Buzzer</b>       | <b>P - S5 Right Boom Raise/Lower Switch</b>           |
| <b>H - Fuse Block</b>                   | <b>Q - S11 Handgun On/Off Switch</b>                  |
| <b>I - K1 Main Disconnect Relay</b>     | <b>R - S4 Left Boom Raise/Lower Switch</b>            |

Sample manual. Download All 162 pages at:

<https://www.bobmanualstore.com/downloads/john-deere-progator-hd200-and-hd300-sprayer-attachment-service-repair-technical-manual/>