

Product: John Deere 655, 755, 855, 955, 756 and 856 Compact Utility Tractors Service Repair Technical Manual
Full Download: <https://www.bobmanualstore.com/downloads/john-deere-655-755-855-955-756-and-856-compact-utility-tractors-service-repair-technical-manual/>

655, 755, 855, 955, 756 and 856 Compact Utility Tractors

TECHNICAL MANUAL

John Deere
Lawn & Grounds Care Division
TM1360 (June 1996)

Sample manual. Download All 570 pages at:

<https://www.bobmanualstore.com/downloads/john-deere-655-755-855-955-756-and-856-compact-utility-tractors-service-repair-technical-manual/>

Litho in U.S.A

Introduction

Product: John Deere 655, 755, 855, 955, 756 and 856 Compact Utility Tractors Service Repair Technical Manual
Full Download: [https://www.bobmanualstore.com/downloads/john-deere-655-755-](https://www.bobmanualstore.com/downloads/john-deere-655-755-855-955-756-and-856-compact-utility-tractors-service-repair-technical-manual/)

FOREWORD

This manual is written for an experienced technician. Essential tools required in performing certain service work are identified in this manual and are recommended for use.

LIVE WITH SAFETY: Read the safety messages in the introduction of this manual and the cautions presented throughout the text of the manual.

PThis is the safety-alert symbol. When you see this symbol on the machine or in this manual, be alert to the potential for personal injury.

Technical manuals are divided in two parts: repair and diagnostics. Repair sections tell how to repair the components. Diagnostic sections help you identify the majority of routine failures quickly.

Information is organized in groups for the various components requiring service instruction. At the beginning of each group are summary listings of all applicable essential tools, service equipment and tools, other materials needed to do the job, service parts kits, specifications, wear tolerances, and torque values.

Binders, binder labels, and tab sets can be ordered by John Deere dealers direct from the John Deere Distribution Service Center.

This manual is part of a total product support program.

FOS MANUALS—REFERENCE

TECHNICAL MANUALS—MACHINE SERVICE

COMPONENT MANUALS—COMPONENT SERVICE

Fundamentals of Service (FOS) Manuals cover basic theory of operation, fundamentals of troubleshooting, general maintenance, and basic type of failures and their causes. FOS Manuals are for training new personnel and for reference by experienced technicians.

Technical Manuals are concise guides for specific machines. Technical manuals are on-the-job guides containing only the vital information needed for diagnosis, analysis, testing, and repair.

Component Technical Manuals are concise service guides for specific components. Component technical manuals are written as stand-alone manuals covering multiple machine applications.

NOTE: The 756 and 856 tractors are identical to the 755 and 855 tractors; therefore, all information pertaining to the 755 also pertains to the 756 and the same is true for the 855 and the 856 tractors. The 655, 756 and 856 tractors were all discontinued before the late model 755 and 855 tractors and the new 955 tractors were produced. Therefore, any late model references do not include the 655, 756, and 856 tractors.

Sample manual. Download All 570 pages at:

<https://www.bobmanualstore.com/downloads/john-deere-655-755-855-955-756-and-856-compact-utility-tractors-service-repair-technical-manual/>

Contents

SECTION 10—GENERAL INFORMATION

- Group 05—Safety
- Group 10—Repair Specifications
- Group 15—Repair Information
- Group 20—Fuels, Lubricants, and Coolants
- Group 25—Serial Number Locations

SECTION 20—DIESEL ENGINE REPAIR

- Group 05—Yanmar Diesel Engine Repair
- Group 10—Remove and Install Oil Cooler
- Group 15—Remove and Install Radiator
- Group 20—Remove and Install Diesel Engine

SECTION 30—FUEL AND AIR REPAIR

- Group 05—Fuel Transfer Pump
- Group 10—Fuel Tank
- Group 15—Fuel Tank Tube and Sender
- Group 20—Air Cleaner

SECTION 40—ALTERNATOR REPAIR

- Group 05—Alternator Repair Specifications
- Group 10—Alternator Installation

SECTION 50—POWER TRAIN REPAIR

- Group 05—Hydrostatic Transmission
- Group 10—Transaxle
- Group 15—Final Drives
- Group 20—Mechanical Front Wheel Drive (MFWD)
- Group 25—Power Train Gears and Shafts
- Group 30—Speed Control Linkage

SECTION 60—STEERING AND BRAKES REPAIR

- Group 05—Standard Front Axle
- Group 10—Steering Valve
- Group 15—Brake Linkage

SECTION 70—HYDRAULICS REPAIR

- Group 05—Hydraulic Pump
- Group 10—Flow Divider and Selective Control Valves (SCV's)
- Group 15—Rockshaft
- Group 20—Hydraulic Hoses

SECTION 80—MISCELLANEOUS REPAIR

- Group 15—Operator's Seat
- Group 20—European Roll-Gard®
- Group 25—German Rear Hitch
- Group 30—3-Point Hitch

SECTION 210—MACHINE OPERATIONAL CHECKOUT PROCEDURE

- Group 05—Machine Operational Checkout Procedure

SECTION 220—ENGINE/FUEL OPERATION AND TESTS

- Group 05—Engine Systems Operational Checkout Procedure
- Group 10—Engine System Diagnosis

SECTION 240—ELECTRICAL OPERATION AND TESTS

- Group 05—Electrical System Checkout
- Group 10—Electrical System Diagnosis
- Group 15—Theory of Operation

SECTION 250—POWER TRAIN OPERATION AND TESTS

- Group 05—Power Train System Checkout
- Group 10—Power Train Tests and Adjustments
- Group 15—Theory of Operation

SECTION 260—STEERING AND BRAKE OPERATION AND TESTS

- Group 05—Steering and Brakes System Checkout
- Group 10—Steering and Brakes Tests and Adjustments
- Group 15—Theory of Operation

SECTION 270—HYDRAULIC OPERATION AND TESTS

- Group 05—Hydraulic System Checkout
- Group 10—Hydraulic System Tests and Adjustments
- Group 15—Theory of Operation

INDEX

All information, illustrations and specifications in this manual are based on the latest information available at the time of publication. The right is reserved to make changes at any time without notice.

TM 1360-19-01Jun 96

COPYRIGHT©1996
DEERE & COMPANY
Moline, Illinois
All rights reserved
A John Deere ILLUSTRATION Manual
Previous Editions
Copyright© 1991, 1990, 1986 Deere & Company

10

20

30

40

50

60

70

80

210

220

240

250

260

270

INDX

Section 10

General Information

Contents

	Page		Page
Group 05—Safety		Group 25—Serial Number Locations	
Safety Items	10-05-1	Product Serial Number	10-25-1
Group 10—Repair Specifications		Engine Serial Number	10-25-1
General Tractor Specifications	10-10-1	Transaxle Serial Number	10-25-1
Group 15—Repair Information		Mower Deck Serial Number	10-25-1
Metric Fastener Torque Values	10-15-1		
Inch Fastener Torque Values	10-15-2		
O-Ring Face Seal Fittings	10-15-3		
O-Ring Boss Fittings	10-15-4		
Group 20—Fuels, Lubricants, and Coolants			
Diesel Fuel—North America	10-20-1		
Diesel Fuel Lubricity—North America	10-20-1		
Diesel Fuel Storage—North America	10-20-1		
Diesel Fuel—Europe	10-20-2		
Diesel Fuel Lubricity—Europe	10-20-2		
Diesel Fuel Storage—Europe	10-20-2		
Engine Oil—North America	10-20-3		
Engine Oil—Europe	10-20-4		
Break-in Engine Oil—North America	10-20-5		
Break-in Engine Oil—Europe	10-20-6		
Hydrostatic Transmission and Hydraulic Oil— North America	10-20-7		
Hydrostatic Transmission and Hydraulic Oil— Europe	10-20-8		
Gear Case Oil (MFWD)—North America	10-20-9		
Gear Case Oil (MFWD)—Europe	10-20-10		
Grease—North America	10-20-11		
Grease—Europe	10-20-12		
North America			
Alternative Lubricants	10-20-13		
Synthetic Lubricants	10-20-13		
Lubricant Storage	10-20-13		
Mixing of Lubricants	10-20-13		
Oil Filters	10-20-13		
Europe			
Alternative Lubricants	10-20-14		
Synthetic Lubricants	10-20-14		
Lubricant Storage	10-20-14		
Mixing of Lubricants	10-20-14		
Oil Filters	10-20-14		
Diesel Engine Coolant—North America	10-20-15		
Diesel Engine Coolant—Europe	10-20-16		

HANDLE FLUIDS SAFELY—AVOID FIRES

When you work around fuel, do not smoke or work near heaters or other fire hazards.

Store flammable fluids away from fire hazards. Do not incinerate or puncture pressurized containers.

Make sure machine is clean of trash, grease, and debris.

Do not store oily rags; they can ignite and burn spontaneously.



DX,FLAME -19-04JUN90

10
05
-UN-23AUG88
TS227

PREVENT BATTERY EXPLOSIONS

Keep sparks, lighted matches, and open flame away from the top of battery. Battery gas can explode.

Never check battery charge by placing a metal object across the posts. Use a volt-meter or hydrometer.

Do not charge a frozen battery; it may explode. Warm battery to 16°C (60°F).

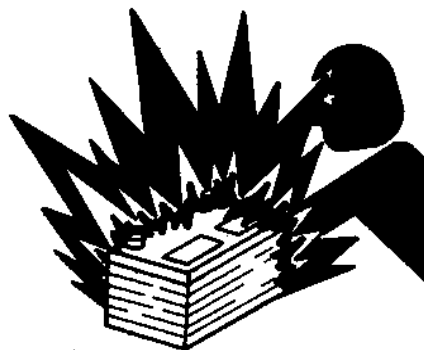

DX,SPARKS -19-04JUN90

-UN-23AUG88
TS204

PREPARE FOR EMERGENCIES

Be prepared if a fire starts.

Keep a first aid kit and fire extinguisher handy.

Keep emergency numbers for doctors, ambulance service, hospital, and fire department near your telephone.

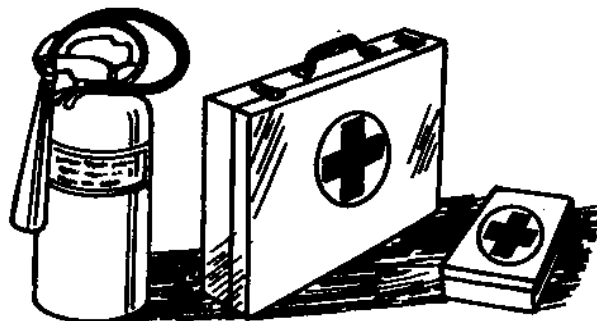

DX,FIRE2 -19-04JUN90

-UN-23AUG88
TS291

PREVENT ACID BURNS

Sulfuric acid in battery electrolyte is poisonous. It is strong enough to burn skin, eat holes in clothing, and cause blindness if splashed into eyes.

Avoid the hazard by:

1. Filling batteries in a well-ventilated area.
2. Wearing eye protection and rubber gloves.
3. Avoiding breathing fumes when electrolyte is added.
4. Avoiding spilling or dripping electrolyte.
5. Use proper jump start procedure.

If you spill acid on yourself:

1. Flush your skin with water.
2. Apply baking soda or lime to help neutralize the acid.
3. Flush your eyes with water for 10—15 minutes. Get medical attention immediately.

If acid is swallowed:

1. Drink large amounts of water or milk.
2. Then drink milk of magnesia, beaten eggs, or vegetable oil.
3. Get medical attention immediately.

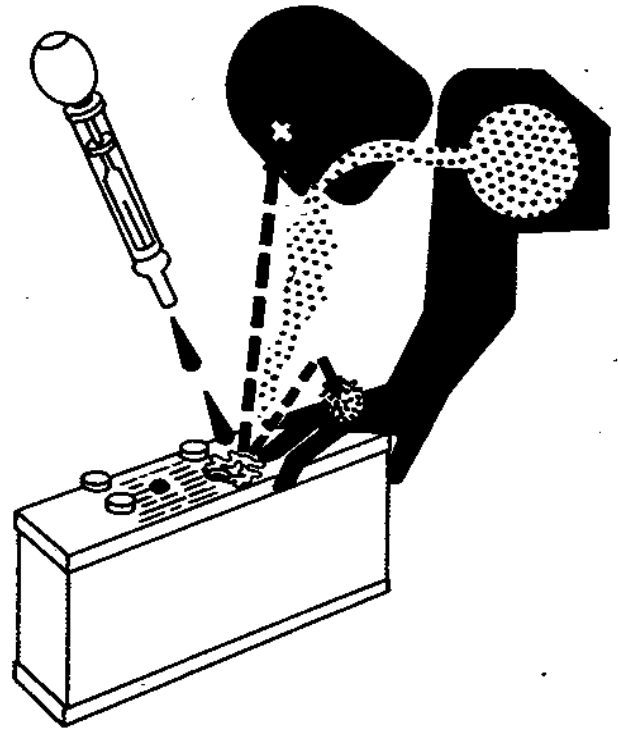

DX, POISON -19-04JUN90

TS203 -UN-23AUG88

AVOID HIGH-PRESSURE FLUIDS

Escaping fluid under pressure can penetrate the skin causing serious injury.

Avoid the hazard by relieving pressure before disconnecting hydraulic or other lines. Tighten all connections before applying pressure.

Search for leaks with a piece of cardboard. Protect hands and body from high pressure fluids.

If an accident occurs, see a doctor immediately. Any fluid injected into the skin must be surgically removed within a few hours or gangrene may result. Doctors unfamiliar with this type of injury should reference a knowledgeable medical source. Such information is available from Deere & Company Medical Department in Moline, Illinois, U.S.A.

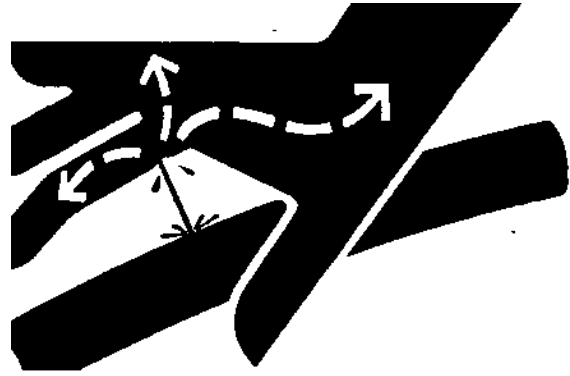

DX,FLUID -19-09AUG91

10
3
9
5
1
-UN-23AUG88
X9811

PARK MACHINE SAFELY

Before working on the machine:

- Lower all equipment to the ground.
- Stop the engine and remove the key.
- Disconnect the battery ground strap.
- Hang a "DO NOT OPERATE" tag in operator station.

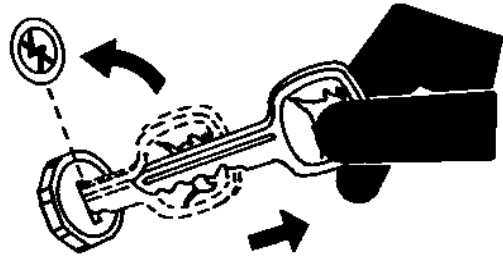

DX,PARK -19-04JUN90

-UN-24MAY69
TS230

10
05
4

SUPPORT MACHINE PROPERLY

Always lower the attachment or implement to the ground before you work on the machine. If you must work on a lifted machine or attachment, securely support the machine or attachment.

Do not support the machine on cinder blocks, hollow tiles, or props that may crumble under continuous load. Do not work under a machine that is supported solely by a jack. Follow recommended procedures in this manual.

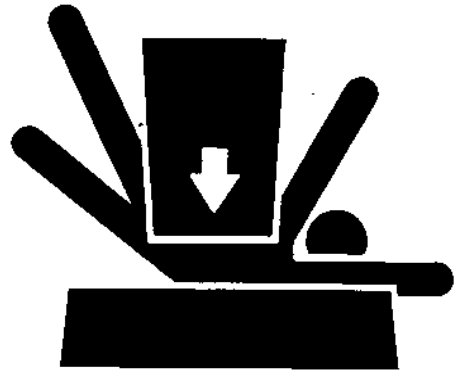

DX,LOWER -19-04JUN90

TS229 -UN-23AUG88

WEAR PROTECTIVE CLOTHING

Wear close fitting clothing and safety equipment appropriate to the job.

Prolonged exposure to loud noise can cause impairment or loss of hearing.

Wear a suitable hearing protective device such as earmuffs or earplugs to protect against objectionable or uncomfortable loud noises.

Operating equipment safely requires the full attention of the operator. Do not wear radio or music headphones while operating machine.

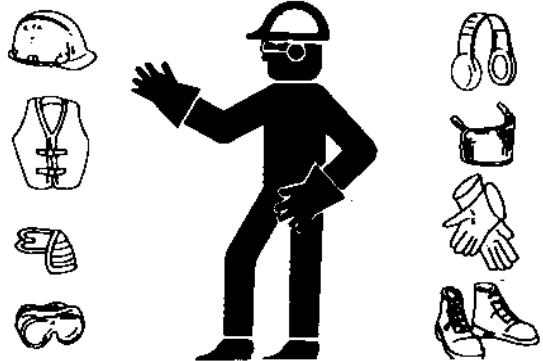

DX,WEAR -19-10SEP90

TS206 -UN-23AUG88

SERVICE MACHINES SAFELY

Tie long hair behind your head. Do not wear a necktie, scarf, loose clothing, or necklace when you work near machine tools or moving parts. If these items were to get caught, severe injury could result.

Remove rings and other jewelry to prevent electrical shorts and entanglement in moving parts.

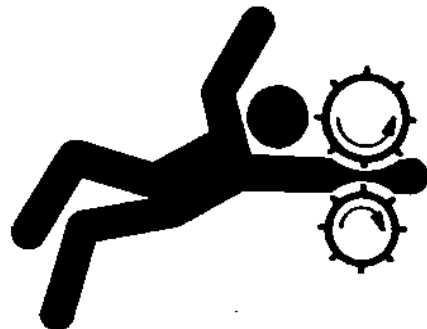

DX,LOOSE -19-04JUN90

TS228 -UN-23AUG88

WORK IN VENTILATED AREA

Engine exhaust fumes can cause sickness or death. If it is necessary to run an engine in an enclosed area, remove the exhaust fumes from the area with an exhaust pipe extension.

If you do not have an exhaust pipe extension, open the doors and get outside air into the area.

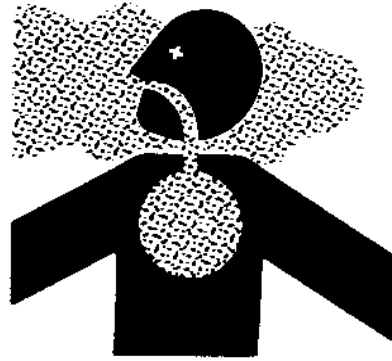

DX,AIR -19-04JUN90

51910
-UN-23AUG88
TS220

ILLUMINATE WORK AREA SAFELY

Illuminate your work area adequately but safely. Use a portable safety light for working inside or under the machine. Make sure the bulb is enclosed by a wire cage. The hot filament of an accidentally broken bulb can ignite spilled fuel or oil.



DX,LIGHT -19-04JUN90

-UN-23AUG88
TS223

REPLACE SAFETY SIGNS

Replace missing or damaged safety signs. See the machine operator's manual for correct safety sign placement.

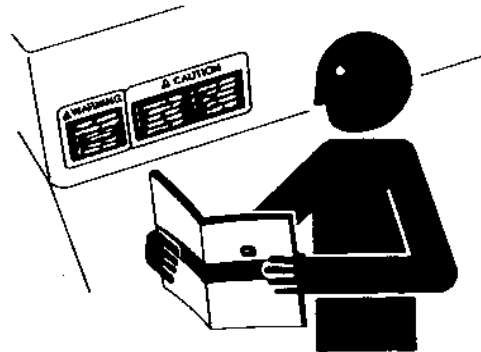

DX,SIGNS1 -19-04JUN90

-UN-23AUG88
TS201

USE PROPER LIFTING EQUIPMENT

Lifting heavy components incorrectly can cause severe injury or machine damage.

Follow recommended procedure for removal and installation of components in the manual.

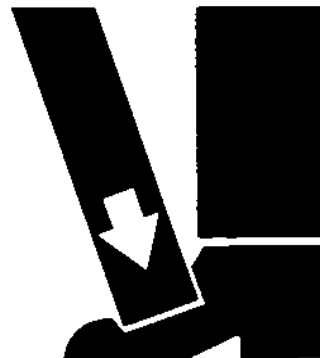

DX,LIFT -19-04JUN90

-UN-23AUG88
TS226

KEEP ROPS INSTALLED PROPERLY

Make certain all parts are reinstalled correctly if the roll-over protective structure (ROPS) is loosened or removed for any reason. Tighten mounting bolts to proper torque.

The protection offered by ROPS will be impaired if ROPS is subjected to structural damage, is involved in an overturn incident, or is in any way altered by welding, bending, drilling, or cutting. A damaged ROPS should be replaced, not reused.

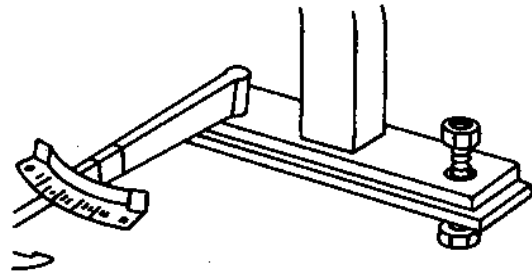

DX,ROPS3 -19-04JUN90

TS212 -UN-23AUG88

SERVICE TIRES SAFELY

Explosive separation of a tire and rim parts can cause serious injury or death.

Do not attempt to mount a tire unless you have the proper equipment and experience to perform the job.

Always maintain the correct tire pressure. Do not inflate the tires above the recommended pressure. Never weld or heat a wheel and tire assembly. The heat can cause an increase in air pressure resulting in a tire explosion. Welding can structurally weaken or deform the wheel.

When inflating tires, use a clip-on chuck and extension hose long enough to allow you to stand to one side and NOT in front of or over the tire assembly. Use a safety cage if available.

Check wheels for low pressure, cuts, bubbles, damaged rims or missing lug bolts and nuts.

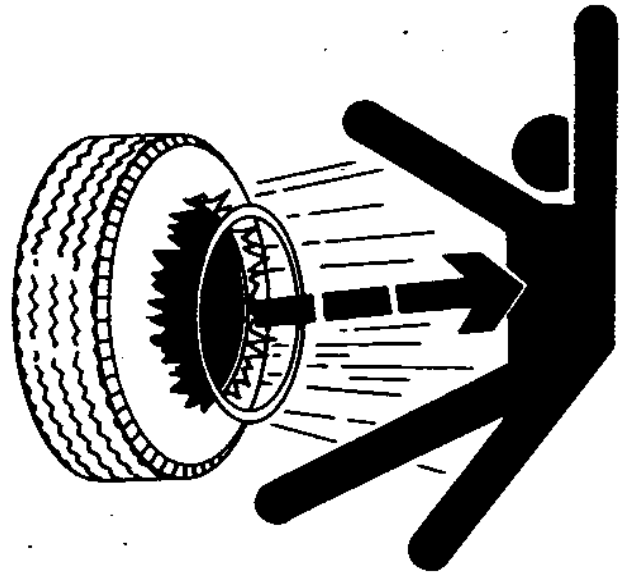

DX,RIM -19-24AUG90

TS211 -UN-23AUG88

AVOID HARMFUL ASBESTOS DUST

Avoid breathing dust that may be generated when handling components containing asbestos fibers. Inhaled asbestos fibers may cause lung cancer.

Components in products that may contain asbestos fibers are brake pads, brake band and lining assemblies, clutch plates, and some gaskets. The asbestos used in these components is usually found in a resin or sealed in some way. Normal handling is not hazardous as long as airborne dust containing asbestos is not generated.

Avoid creating dust. Never use compressed air for cleaning. Avoid brushing or grinding material containing asbestos. When servicing, wear an approved respirator. A special vacuum cleaner is recommended to clean asbestos. If not available, apply a mist of oil or water on the material containing asbestos.

Keep bystanders away from the area.

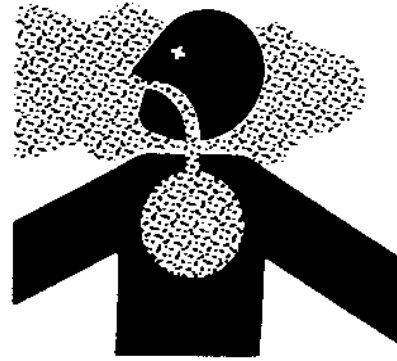

DX,DUST -19-15MAR91

10
05
7
-UN-23AUG88
TS220

WORK IN CLEAN AREA

Before starting a job:

- Clean work area and machine.
- Make sure you have all necessary tools to do your job.
- Have the right parts on hand.
- Read all instructions thoroughly; do not attempt shortcuts.

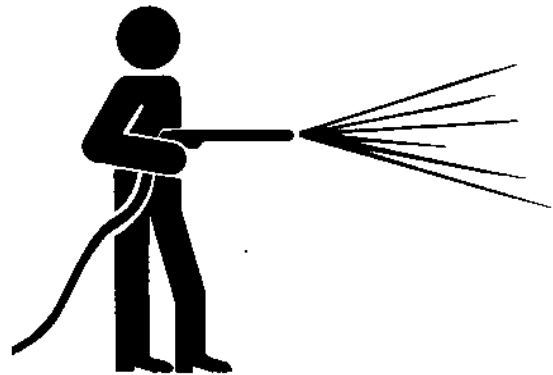

DX,CLEAN -19-04JUN90

T6642EJ -UN-18OCT88

USE PROPER TOOLS

Use tools appropriate to the work. Makeshift tools and procedures can create safety hazards.

Use power tools only to loosen threaded parts and fasteners.

For loosening and tightening hardware, use the correct size tools. DO NOT use U.S. measurement tools on metric fasteners. Avoid bodily injury caused by slipping wrenches.

Use only service parts meeting John Deere specifications.



TS779 -UN-08NOV89

DX,REPAIR -19-04JUN90

DISPOSE OF WASTE PROPERLY

Improperly disposing of waste can threaten the environment and ecology. Potentially harmful waste used with John Deere equipment include such items as oil, fuel, coolant, brake fluid, filters, and batteries.

Use leakproof containers when draining fluids. Do not use food or beverage containers that may mislead someone into drinking from them.

Do not pour waste onto the ground, down a drain, or into any water source.

Air conditioning refrigerants escaping into the air can damage the Earth's atmosphere. Government regulations may require a certified air conditioning service center to recover and recycle used air conditioning refrigerants.

Inquire on the proper way to recycle or dispose of waste from your local environmental or recycling center, or from your John Deere dealer.

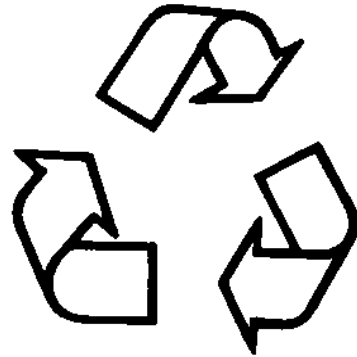

TS1133 -UN-26NOV90

DX,DRAIN -19-09AUG91

LIVE WITH SAFETY

Before returning machine to customer, make sure machine is functioning properly, especially the safety systems. Install all guards and shields.



DX,LIVE

-19-04JUN90

TS231 -19-07OCT88

10
9
5

10
05
10

GENERAL TRACTOR SPECIFICATIONS

ITEM	655	755/756	855/856	955
ENGINE:				
Engine Model	3TN66UJ	3TNA72UJ	3TN75RJ	3TN84RJ
Engine Horsepower, Net.	16 (11.9 kW)	20 (14.9 kW)	24 (17.9 kW)	33 (24.6 kW)
PTO Horsepower	10.6 (8.1 kW)	15 (11.2 kW)	19 (14.2 kW)	27 (20.1 kW)
Rated Engine Speed.	3200 rpm	3200 rpm	3200 rpm	3200 rpm
Type	Diesel	Diesel	Diesel	Diesel
Operating Range	1400-3425 rpm	1400-3425 rpm	1400-3425 rpm	1400-3425 rpm
Number of Cylinders	3	3	3	3
Displacement	40.2 cu. in. 658 cm ³	53.6 cu. in. 879 cm ³	60.7 cu. in. 995 cm ³	87.3 cu. in. 1430 cm ³
Bore and Stroke	2.59x2.53 in. (66x64.2 mm)	2.83x2.83 in. (72x72 mm)	2.95x2.95 in. (75x75 mm)	3.31x3.39 in. (84x86 mm)
Compression Ratio	22.4:1	22.3:1	17.8:1	18.0:1
Lubrication	Pressured	Pressured	Pressured	Pressured
Cooling System.	Water-pump	Water-pump	Water-pump	Water-pump
Air Cleaner	Dry-Type with Safety Element	Dry-Type with Safety Element	Dry-Type with Safety Element	Dry-Type with Safety Element
Engine Shutoff	Key	Key	Key	Key
Engine Torque at Rated Speed.	35 N•m (26 lb-ft)	45 N•m (33 lb-ft)	58 N•m (39 lb-ft)	73 N•m (54 lb-ft)
ELECTRICAL SYSTEM:				
Type	12 volt	12 volt	12 volt	12 volt
Battery Size	491 Cold Cranking Amps @ -18° C	491 Cold Cranking Amps @ -18° C	475 Cold Cranking Amps @ -18° C	475 Cold Cranking Amps @ -18° C
Alternator	35 Amp 40 Amp	35 Amp 40 Amp	35 Amp 40 Amp	N/A 40 Amp
Starter Size	1.3 hp (1.0 kW)	1.3 hp (1.0 kW)	1.3 hp (1.0 kW)	1.9 hp (1.4 kW)
FUEL SYSTEM:				
Type	Indirect Injection	Indirect Injection	Direct Injection	Direct Injection
Injection Pump Type	In-line with Electric Shutoff	In-line with Electric Shutoff	In-line with Electric Shutoff	In-line with Electric Shutoff
Gallon/hr at 75% load (mowing)	Not Available	0.86	0.79	1.4
DRIVE TRAIN:				
Transmission Type	Hydrostatic-2-range	Hydrostatic-2-range	Hydrostatic-2-range	Hydrostatic-2-range
Transaxle Speed Ranges	High/Lo	High/Lo	High/Lo	High/Lo
Number of Speeds	Infinite	Infinite	Infinite	Infinite
Final Drive.	Planetary	Planetary	Planetary	Planetary
Brakes.	Wet Disk	Wet Disk	Wet Disk	Wet Disk
Steering	Power	Power	Power	Power
Drawbar Tonque Weight Capacity	675 lb. (306 kg)	675 lb. (306 kg)	675 lb. (306 kg)	800 lb. (363 kg)

GENERAL SPECIFICATIONS—CONTINUED

ITEM	655	755/756	855/856	955
HYDRAULIC SYSTEM:				
Type of System	Open Center	Open Center	Open Center	Open Center
Working Pressure	2050 psi (14135 kPa)	2050 psi (14135 kPa)	2050 psi (14135 kPa)	2500 psi (17240 kPa)
Pump Type	Gerotor Gear	Gerotor Gear	Gerotor Gear	Gerotor Gear
Pump Capacity	4 gpm (0.25 L/s)	5.6 gpm (0.35 L/s)	5.6 gpm (0.35 L/s)	7.2 gpm (0.45 L/s)
3-PT. Hitch Type	Cat. 1 (Standard)	Cat. 1 (Standard)	Cat. 1	Cat. 1
Hitch Lift Capacity (24 in. behind link arms)				
Early Models	785 lbs. (357 kg)	785 lbs. (357 kg)	785 lbs. (357 kg)	957 lbs. (434 kg)
Late Models or Retrofit	N/A	SN 180250— 1005 lbs. (456 kg)	SN 180450— 1005 lbs. (456 kg)	SN 180525— 1177 lbs. (534 kg)
Lift Control Type	Position	Position	Position	Position
PTO:				
Type	Live Independent	Live Independent	Live Independent	Live Independent
Speed (PTO rpm at 3200 engine rpm—full load):				
Mid (1:1 gear ratio)	2100 rpm	2100 rpm	2100 rpm	2100 rpm
Rear (1:3 gear ratio)	540 rpm	540 rpm	540 rpm	540 rpm
Clutch	Hydraulic Multi-Disk	Hydraulic Multi-Disk	Hydraulic Multi-Disk	Hydraulic Multi-Disk
Brake	Hydraulically Controlled	Hydraulically Controlled	Hydraulically Controlled	Hydraulically Controlled
MOWER BLADE TIP SPEED (at 3200 engine rpm full load):				
50 Inch Mower	15,371 ft/min (4688 m/min)	N/A	N/A	N/A
1:1.04 Gear Ratio	Spindle rpm 3389	N/A	N/A	N/A
60 Inch Mower	N/A	15,471 ft/min (4719 m/min)	15,471 ft/min (4719 m/min)	15,471 ft/min (4719 m/min)
1:1 Gear Ratio	N/A	Spindle rpm 2883	Spindle rpm 2883	Spindle rpm 2883
72 Inch Mower	N/A	15,167 ft/min (4626 m/min)	15,167 ft/min (4626 m/min)	15,167 ft/min (4626 m/min)
1:1 Gear Ratio	N/A	Spindle rpm 2321	Spindle rpm 2321	Spindle rpm 2321
261 Inch Mower	N/A	14,465 ft/min (4412 m/min)	14,465 ft/min (4412 m/min)	14,465 ft/min (4412 m/min)
1:3 Gear Ratio	N/A	Spindle rpm 2695	Spindle rpm 2695	Spindle rpm 2695
272 Inch Mower	N/A	14,601 ft/min (4453 m/min)	14,601 ft/min (4453 m/min)	14,601 ft/min (4453 m/min)
1:3 Gear Ratio	N/A	Spindle rpm 2234	Spindle rpm 2234	Spindle rpm 2234

GENERAL SPECIFICATIONS—CONTINUED

ITEM	655	755/756	855/856	955
FLUID CAPACITIES:				
Fuel Tank	3.95 U.S. gal (15 L)	4.4 U.S. gal (16.7 L)	6.6 U.S. gal (25 L)	6.6 U.S. gal (25 L)
Cooling System	4 U.S. qt. (3.8 L)	4 U.S. qt. (3.8 L)	4.8 U.S. qt. (4.5 L)	4.8 U.S. qt. (4.5 L)
Crankcase (w/filter)	2.5 U.S. qt. (2.4 L)	2.86 U.S. qt. (2.7 L)	4.1 U.S. qt. (3.9 L)	4.4 U.S. qt. (4.2 L)
Transmission and Hydraulic System	4.5 U.S. gal. (17 L)	4.5 U.S. gal. (17 L)	4.5 U.S. gal. (17 L)	4.5 U.S. gal. (17 L)
MFWD Gear Case	2.25 U.S. qt. (2.13 L)	2.25 U.S. qt. (2.13 L)	2.25 U.S. qt. (2.13 L)	3.5 U.S. qt. (3.3 L)
WEIGHT (includes fuel, oil, coolant and R-1 tires):				
2WD	1584 lbs. (718 kg)	1700 lbs. (771 kg)	1790 lbs. (812 kg)	N/A
MFWD	1680 lbs. (762 kg)	1835 lbs. (832 kg)	1870 lbs. (848 kg)	1990 lbs. (903 kg)
SERVICE INTERVALS:				
Engine				
Valve Adjustment	300 Hours	300 Hours	300 Hours	300 Hours
Primary Filter	400 Hours	400 Hours	400 Hours	400 Hours
		or every two years		
Secondary Filter	Every two years	Every two years	Every two years	Every two years
		or when every third primary filter is installed		
GROUND SPEEDS (at full engine rpm):				
Forward High Range	0—10.0 mph (0—16.1 K/hr)	0—10.6 mph (0—17.1 K/hr)	0—11.0 mph (0—17.7 K/hr)	0—11.4 mph (0—18.3 K/hr)
Forward Lo Range	0—05.4 mph (0—08.7 K/hr)	0—05.8 mph (0—09.3 K/hr)	0—06.0 mph (0—09.7 K/hr)	0—05.1 mph (0—08.2 K/hr)
Reverse High And Lo	0—05.0 mph (0—08.1 K/hr)	0—05.3 mph (0—08.5 K/hr)	0—05.5 mph (0—08.9 K/hr)	0—05.7 mph (0—09.2 K/hr)
ENGINE COOLANT HEATER:				
	Current Draw 400 Watts	Current Draw 400 Watts	Current Draw 400 Watts	Current Draw 400 Watts
SPARK ARRESTER:				
	Not Available	Available	Available	Available

METRIC FASTENER TORQUE VALUES

Property Class and Head Markings	<p>4.8</p>	<p>8.8 9.8</p>	<p>10.9</p>	<p>12.9</p>
Property Class and Nut Markings	<p>5</p>	<p>10</p>	<p>10</p>	<p>12</p>

TS1163

SIZE	Class 4.8				Class 8.8 or 9.8				Class 10.9				Class 12.9			
	Lubricated ^a		Dry ^a		Lubricated ^a		Dry ^a		Lubricated ^a		Dry ^a		Lubricated ^a		Dry ^a	
	N•m	lb-ft	N•m	lb-ft	N•m	lb-ft	N•m	lb-ft	N•m	lb-ft	N•m	lb-ft	N•m	lb-ft	N•m	lb-ft
M6	48	3.5	6	4.5	9	6.5	11	8.5	13	9.5	17	12	15	11.5	19	14.5
M8	12	8.5	15	11	22	16	28	20	32	24	40	30	37	28	47	35
M10	23	17	29	21	43	32	55	40	63	47	80	60	75	55	95	70
M12	40	29	50	37	75	55	95	70	110	80	140	105	130	95	165	120
M14	63	47	80	60	120	88	150	110	175	130	225	165	205	150	260	109
M16	100	73	125	92	190	140	240	175	275	200	350	225	320	240	400	300
M18	135	100	175	125	260	195	330	250	375	275	475	350	440	325	560	410
M20	190	140	240	180	375	275	475	350	530	400	675	500	625	460	800	580
M22	260	190	330	250	510	375	650	475	725	540	925	675	850	625	1075	800
M24	330	250	425	310	650	475	825	600	925	675	1150	850	1075	800	1350	1000
M27	490	360	625	450	950	700	1200	875	1350	1000	1700	1250	1600	1150	2000	1500
M30	675	490	850	625	1300	950	1650	1200	1850	1350	2300	1700	2150	1600	2700	2000
M33	900	675	1150	850	1750	1300	2200	1650	2500	1850	3150	2350	2900	2150	3700	2750
M36	1150	850	1450	1075	2250	1650	2850	2100	3200	2350	4050	3000	3750	2750	4750	3500

DO NOT use these hand torque values if a different torque value or tightening procedure is given for a specific application. Torque values listed are for general use only and include a ±10% variance factor. Check tightness of fasteners periodically. DO NOT use air powered wrenches.

Shear bolts are designed to fail under predetermined loads. Always replace shear bolts with identical grade.

Fasteners should be replaced with the same grade. Make sure fastener threads are clean and that you properly start thread engagement. This will prevent them from failing when tightening.











When bolt and nut combination fasteners are used, torque values should be applied to the **NUT** instead of the bolt head.

Tighten toothed or serrated-type lock nuts to the full torque value.

^a "Lubricated" means coated with a lubricant such as engine oil, or fasteners with phosphate and oil coatings. "Dry" means plain or zinc plated (yellow dichromate - Specification JDS117) without any lubrication.

Reference: JDS—G200.

INCH FASTENER TORQUE VALUES

SAE Grade and Head Markings	1 or 2 ^b No Marks 	5  5.1  5.2 	8  8.2 
	2 No Marks 	5  	8  

TS1162

SIZE	Grade 1				Grade 2 ^b				Grade 5, 5.1 or 5.2				Grade 8 or 8.2			
	Lubricated ^a		Dry ^a		Lubricated ^a		Dry ^a		Lubricated ^a		Dry ^a		Lubricated ^a		Dry ^a	
	N•m	lb-ft	N•m	lb-ft	N•m	lb-ft	N•m	lb-ft	N•m	lb-ft	N•m	lb-ft	N•m	lb-ft	N•m	lb-ft
1/4	3.7	2.8	4.7	3.5	6	4.5	7.5	5.5	9.5	7	12	9	13.5	10	17	12.5
5/16	7.7	5.5	10	7	12	9	15	11	20	15	25	18	28	21	35	26
3/8	14	10	17	13	22	16	27	20	35	26	44	33	50	36	63	46
7/16	22	16	28	20	35	26	44	32	55	41	70	52	80	58	100	75
1/2	33	25	42	31	53	39	67	50	85	63	110	80	120	90	150	115
9/16	48	36	60	45	75	56	95	70	125	90	155	115	175	130	225	160
5/8	67	50	85	62	105	78	135	100	170	125	215	160	215	160	300	225
3/4	120	87	150	110	190	140	240	175	300	225	375	280	425	310	550	400
7/8	190	140	240	175	190	140	240	175	490	360	625	450	700	500	875	650
1	290	210	360	270	290	210	360	270	725	540	925	675	1050	750	1300	975
1-1/8	470	300	510	375	470	300	510	375	900	675	1150	850	1450	1075	1850	1350
1-1/4	570	425	725	530	570	425	725	530	1300	950	1650	1200	2050	1500	2600	1950
1-3/8	750	550	950	700	750	550	950	700	1700	1250	2150	1550	2700	2000	3400	2550
1-1/2	1000	725	1250	925	990	725	1250	930	2250	1650	2850	2100	3600	2650	4550	3350

DO NOT use these hand torque values if a different torque value or tightening procedure is given for a specific application. Torque values listed are for general use only and include a ±10% variance factor. Check tightness of fasteners periodically. DO NOT use air powered wrenches.

Shear bolts are designed to fail under predetermined loads. Always replace shear bolts with identical grade.

Fasteners should be replaced with the same grade. Make sure fastener threads are clean and that you properly start thread engagement. This will prevent them from failing when tightening.

When bolt and nut combination fasteners are used, torque values should be applied to the **NUT** instead of the bolt head.

Tighten toothed or serrated-type lock nuts to the full torque value.

^a "Lubricated" means coated with a lubricant such as engine oil, or fasteners with phosphate and oil coatings. "Dry" means plain or zinc plated (yellow dichromate - Specification JDS117) without any lubrication.

^b "Grade 2" applies for hex cap screws (not hex bolts) up to 152 mm (6-in.) long. "Grade 1" applies for hex cap screws over 152 mm (6-in.) long, and for all other types of bolts and screws of any length.

Reference: JDS—G200.

SERVICE RECOMMENDATIONS

O-RING FACE SEAL FITTINGS

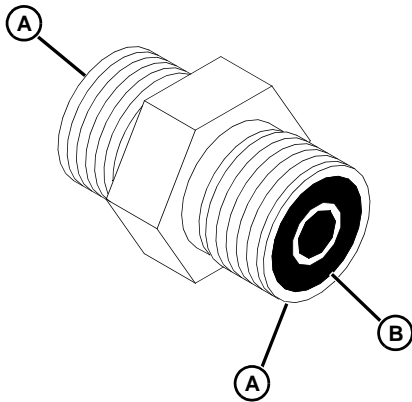

1. Inspect the fitting sealing surfaces (A). They must be free of dirt or defects.
2. Inspect the O-ring (B). It must be free of damage or defects.
3. Lubricate O-rings and install into groove using petroleum jelly to hold in place.
4. Push O-ring into the groove with plenty of petroleum jelly so O-ring is not displaced during assembly.
5. Index angle fittings and tighten by hand pressing joint together to insure O-ring remains in place.
6. Tighten fitting or nut to torque value shown on the chart per dash size stamped on the fitting. Do not allow hoses to twist when tightening fittings.

O-RING FACE SEAL FITTING INCH TORQUE

NOMINAL		Dash Size	THREAD	SWIVEL NUT		BULKHEAD	
Tube O.D.			Size	Torque		Nut Torque	
mm	in.		in.	N•m	lb-ft	N•m	lb-ft
6.35	0.250	-4	9/16-18	16	12	5.0	3.5
9.52	0.375	-6	11/16-16	24	18	9.0	6.5
12.70	0.500	-8	13/16-16	50	37	17.0	12.5
15.88	0.625	-10	1-14	69	51	17.0	12.5
19.05	0.750	-12	1 3/16-12	102	75	17.0	12.5
22.22	0.875	-14	1 3/16-12	102	75	17.0	12.5
25.40	1.000	-16	1 7/16-12	142	105	17.0	12.5
31.75	1.250	-20	1 11/16-12	190	140	17.0	12.5
38.10	1.500	-24	2-12	217	160	17.0	12.5

NOTE: Torque tolerance is + 15 -20%.

O-RING BOSS FITTINGS

1. Inspect boss O-ring boss seat. It must be free of dirt and defects. If repeated leaks occur, inspect for defects with a magnifying glass. Some raised defects can be removed with a slip stone.

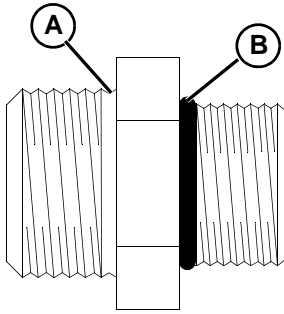

2. Put hydraulic oil or petroleum jelly on the O-ring (B). Place electrical tape over the threads to protect O-ring from nicks. Slide O-ring over the tape and into the groove (A) of fitting. Remove tape.

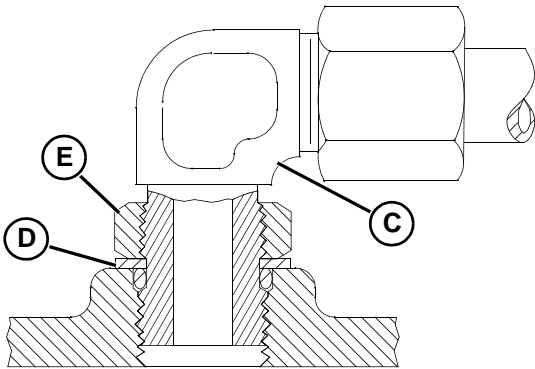

3. For angle fittings (C), loosen special nut (E) and push special washer (D) against threads so O-ring can be installed into the groove of fitting.
4. Turn fitting into the boss by hand until special washer or washer face (straight fitting) contacts boss face and O-ring is squeezed into its seat.
5. To position angle fittings, turn the fitting counter-clockwise a maximum of one turn.
6. Tighten straight fittings to torque value shown on chart. For angle fittings, tighten the special nut to value shown in the chart while holding body of fitting with a wrench.

STRAIGHT FITTING OR SPECIAL NUT TORQUE

Thread Size	Torque ^a		Number of Flats ^b
	N•m	lb-ft	
3/8-24 UNF	8	(6)	2
7/16-20 UNF	12	(9)	2
1/2-20 UNF	16	(12)	2
9/16-18 UNF	24	(18)	2
3/4-16 UNF	46	(34)	2
7/8-14 UNF	62	(46)	1-1/2
1-1/16-12 UN	102	(75)	1
1-3/16-12 UN	122	(90)	1
1-5/16-12 UN	142	(105)	3/4
1-5/8-12 UN	190	(140)	3/4
1-7/8-12 UN	217	(160)	1/2

a. Torque tolerance is ± 10 percent.

b. To be used if a torque wrench cannot be used. After tightening fitting by hand, put a mark on nut or boss; then tighten special nut or straight fitting the number of flats shown.

DIESEL FUEL - NORTH AMERICA

In general, diesel fuels are blended to satisfy the low air temperature requirements of the geographical area in which they are sold.

In North America, diesel fuel is usually specified to **ASTM D975** and sold as either **Grade 1** for cold air temperatures or **Grade 2** for warm air temperatures.

If diesel fuels being supplied in your area **DO NOT** meet any of the above specifications, use diesel fuels with the following equivalent properties:

- Cetane Number 40 (minimum)

A cetane number **greater than 50 is preferred**, especially for air temperatures below -20°C (-4°F) or elevations above 1500 m (5000 ft).

- Cold Filter Plugging Point (CFPP)

The air temperature at which diesel fuel **begins to cloud or jell** — at least 5°C (9°F) below the expected low air temperature range.

- Sulfur Content of 0.05%

Diesel fuels for highway use in the United States now require sulfur content to be **less than 0.05%**.

If diesel fuel being used has a sulfur content **greater than 0.05%**, **reduce the service interval** for engine oil and filter by **50%**.

Consult your local diesel fuel distributor for properties of the diesel fuel available in your area.



California Proposition 65 Warning: Diesel engine exhaust and some of its elements from this product are known to the State of California to cause cancer, birth defects, or other reproductive harm.

DIESEL FUEL LUBRICITY

Diesel fuel must have adequate lubricity to ensure proper operation and durability of fuel injection system components. Fuel lubricity should pass a **minimum of 3300 gram load level** as measured by the **BOCLE** scuffing test.

DIESEL FUEL STORAGE

IMPORTANT: DO NOT USE GALVANIZED CONTAINERS—diesel fuel stored in galvanized containers reacts with zinc coating in the container to form zinc flakes. If fuel contains water, a zinc gel will also form. The gel and flakes will quickly plug fuel filters and damage fuel injectors and fuel pumps.

It is recommended that diesel fuel be stored **ONLY** in a clean, approved **POLYETHYLENE PLASTIC** container **WITHOUT** any metal screen or filter. This will help prevent any accidental sparks from occurring. Store fuel in an area that is well ventilated to prevent possible igniting of fumes by an open flame or spark, this includes any appliance with a pilot light.

IMPORTANT: Keep all dirt, scale, water or other foreign material out of fuel.

Keep fuel in a safe, protected area and in a clean, properly marked (“**DIESEL FUEL**”) container. **DO NOT** use deicers to attempt to remove water from fuel. **DO NOT** depend on fuel filters to remove water from fuel. It is recommended that a water separator be installed in the storage tank outlet. **BE SURE** to properly discard unstable or contaminated diesel fuel and/or their containers when necessary.

DIESEL FUEL - EUROPE

In general, diesel fuels are blended to satisfy the low air temperature requirements of the geographical area in which they are sold.

In Europe, diesel fuel is usually specified to **EN590** and sold in 5 different classes or 6 different grades.

If diesel fuels being supplied in your area **DO NOT** meet any of the above specifications, use diesel fuels with the following equivalent properties:

- Cetane Number 40 (minimum)

A cetane number **greater than 50 is preferred**, especially for air temperatures below -20°C (-4°F) or elevations above 1500 m (5000 ft).

If diesel fuel being used has a sulfur content **greater than 0.05%**, reduce the service interval for engine oil and filter by **50%**.

Consult your local diesel fuel distributor for properties of the diesel fuel available in your area.

- Cold Filter Plugging Point (CFPP)

The air temperature at which diesel fuel **begins to cloud or jell** — at least 5°C (9°F) below the expected low air temperature range.

- Sulfur Content of 0.05%

Diesel fuel for highway use in the European Union will be required to have a sulfur content of **less than 0.05%** by **1 October 1996**.

If diesel fuel being used has a sulfur content **greater than 0.05%**, reduce the service interval for engine oil and filter by **50%**.

Consult your local diesel fuel distributor for properties of the diesel fuel available in your area.

DIESEL FUEL LUBRICITY

Diesel fuel must have adequate lubricity to ensure proper operation and durability of fuel injection system components. Fuel lubricity should pass a **minimum of 3300 gram load level** as measured by the **BOCLE** scuffing test.

DIESEL FUEL STORAGE

IMPORTANT: DO NOT USE GALVANIZED CONTAINERS—diesel fuel stored in galvanized containers reacts with zinc coating in the container to form zinc flakes. If fuel contains water, a zinc gel will also form. The gel and flakes will quickly plug fuel filters and damage fuel injectors and fuel pumps.

It is recommended that diesel fuel be stored **ONLY** in a clean, approved **POLYETHYLENE PLASTIC** container **WITHOUT** any metal screen or filter. This will help prevent any accidental sparks from occurring. Store fuel

in an area that is well ventilated to prevent possible igniting of fumes by an open flame or spark, this includes any appliance with a pilot light.

IMPORTANT: Keep all dirt, scale, water or other foreign material out of fuel.

Keep fuel in a safe, protected area and in a clean, properly marked (“**DIESEL FUEL**”) container. **DO NOT** use deicers to attempt to remove water from fuel. **DO NOT** depend on fuel filters to remove water from fuel. It is recommended that a water separator be installed in the storage tank outlet. **BE SURE** to properly discard unstable or contaminated diesel fuel and/or their containers when necessary.

4-CYCLE DIESEL ENGINE OIL - NORTH AMERICA

Use appropriate oil viscosity based on the expected air temperature range during the period between recommended oil changes. Operating outside of these recommended oil air temperature ranges may cause premature engine failure.

The following John Deere oils are **PREFERRED**:

- PLUS-50®—SAE 15W-40;**
- TORQ-GARD SUPREME®—SAE 5W-30.**

The following John Deere oils are **also recommended**, based on their specified temperature range:

- TURF-GARD®—SAE 10W-30;**
- PLUS-4®—SAE 10W-30;**
- TORQ-GARD SUPREME®—SAE 30.**

Other oils may be used if above John Deere oils are not available, provided they meet one of the following specifications:

- SAE 15W-40 (preferred)—API Service Classifications CG-4 or CF-4 or higher;
- SAE 5W-30 (preferred)—API Service Classification CD or CC or higher;
- SAE 10W-30—API Service Classification CF-4 or CF or higher;
- SAE 30—API Service Classification CF-4 or CF or higher.

IMPORTANT: If diesel fuel with sulfur content greater than 0.5% is used, reduce the service interval for oil and filter by 50%.

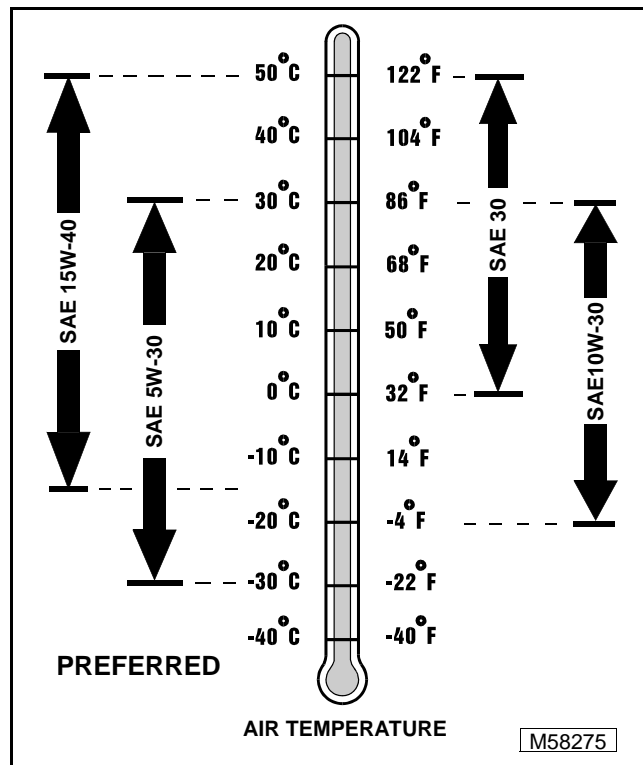

John Deere Dealers: You may want to cross-reference the following publications to recommend the proper oil for your customers:

- Module DX, ENOIL in JDS-G135;
- Section 530, Lubricants & Hydraulics, of the John Deere Merchandise Sales Guide;
- Lubrication Sales Manual PI7032.

4-CYCLE DIESEL ENGINE OIL - EUROPE

Use appropriate oil viscosity based on the expected air temperature range during the period between recommended oil changes. Operating outside of these recommended oil air temperature ranges may cause premature engine failure.

The following John Deere oils are **PREFERRED**:

- TORQ-GARD SUPREME®—SAE 15W-40;
- UNI-GARD™—SAE 15W-40;
- TORQ-GARD SUPREME®—SAE 5W-30;
- UNI-GARD™—SAE 5W-30.

The following John Deere oils are **also recommended**, based on their specified temperature range:

- TORQ-GARD SUPREME®—SAE 10W-30;
- UNI-GARD™—SAE 10W-30;
- TORQ-GARD SUPREME®—SAE 30;
- UNI-GARD™—SAE 30.

Other oils may be used if above John Deere oils are not available, provided they meet one of the following specifications:

- CCMC Specification D5 or Mercedes Benz MB228.3 or higher;
- CCMC Specification D4 or Mercedes Benz MB228.1 or higher.

IMPORTANT: If diesel fuel with sulfur content greater than 0.5% is used, reduce the service interval for oil and filter by 50%.

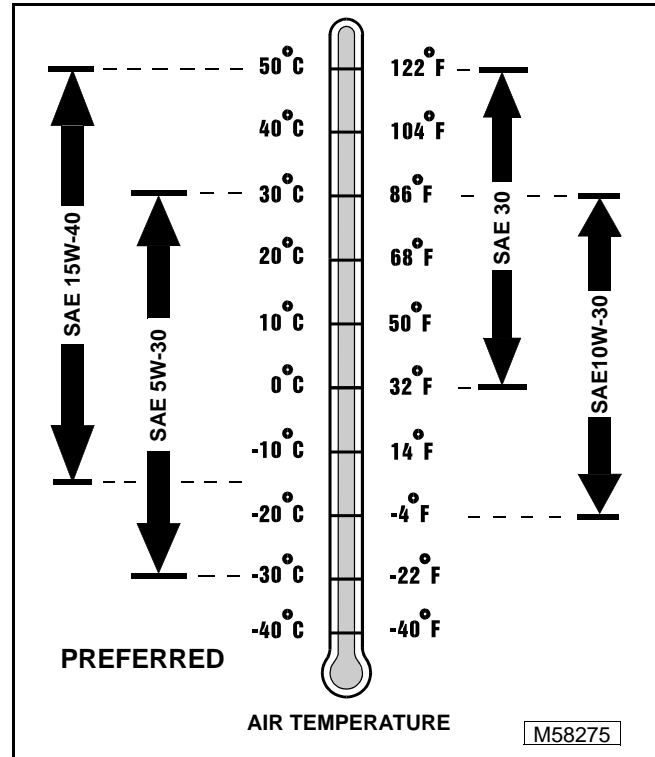

John Deere Dealers: You may want to cross-reference the following publications to recommend the proper oil for your customers:

- Module DX, ENOIL in JDS-G135;
- Section 530, Lubricants & Hydraulics, of the John Deere Merchandise Sales Guide.

BREAK-IN DIESEL ENGINE OIL - NORTH AMERICA

IMPORTANT: ONLY use this specified break-in oil in rebuilt or remanufactured engines for the first 100 hours maximum. DO NOT use PLUS-50®, SAE 15W40 oil or oils meeting specifications API CG-4 or API CF-4, these oils will not allow rebuilt or remanufactured engines to break-in properly.

The following John Deere oil is **PREFERRED**:

•**BREAK-IN ENGINE OIL.**

John Deere BREAK-IN ENGINE OIL is formulated with special additives for aluminum and cast iron type engines to allow the power cylinder components (pistons, rings, and liners as well) to “wear-in” while protecting other engine components, valve train and gears, from abnormal wear. Engine rebuild instructions should be followed closely to determine if special requirements are necessary.

John Deere BREAK-IN ENGINE OIL is also recommended for non-John Deere engines, both aluminum and cast iron types.

If this preferred John Deere oil is not available, use a break-in engine oil meeting the following specification during the first 100 hours of operation:

•API Service Classification CE.

After the break-in period, use the John Deere oil that is recommended for this engine.

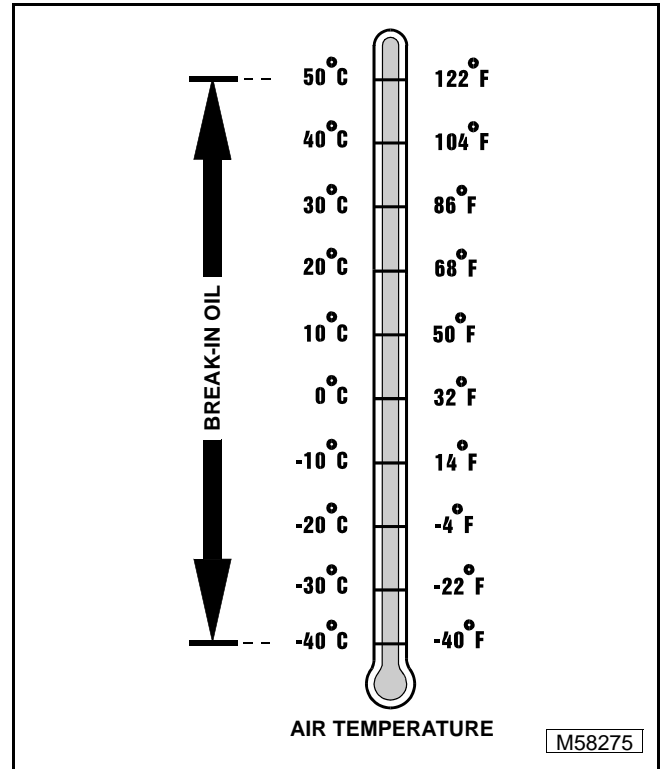

John Deere Dealers: You may want to cross-reference the following publications to recommend the proper oil for your customers:

- Module DX, ENOIL4 in JDS-G135;
- Section 530, Lubricants & Hydraulics, of the John Deere Merchandise Sales Guide;
- Lubrication Sales Manual PI7032.

BREAK-IN DIESEL ENGINE OIL - EUROPE

IMPORTANT: ONLY use this specified break-in oil in rebuilt or remanufactured engines for the first 100 hours maximum. DO NOT use SAE 15W-40 oil or oils meeting CCMC Specification D5—these oils will not allow rebuilt or remanufactured engines to break-in properly.

The following John Deere oil is **PREFERRED:**
•**BREAK-IN ENGINE OIL.**

John Deere BREAK-IN ENGINE OIL is formulated with special additives for aluminum and cast iron type engines to allow the power cylinder components (pistons, rings, and liners as well) to “wear-in” while protecting other engine components, valve train and gears, from abnormal wear. Engine rebuild instructions should be followed closely to determine if special requirements are necessary.

John Deere BREAK-IN ENGINE OIL is also recommended for non-John Deere engines, both aluminum and cast iron types.

If above preferred John Deere oil is not available, use a break-in engine oil meeting the following specification during the first 100 hours of operation:
•CCMC Specification D4.

After the break-in period, use the John Deere oil that is recommended for this engine.

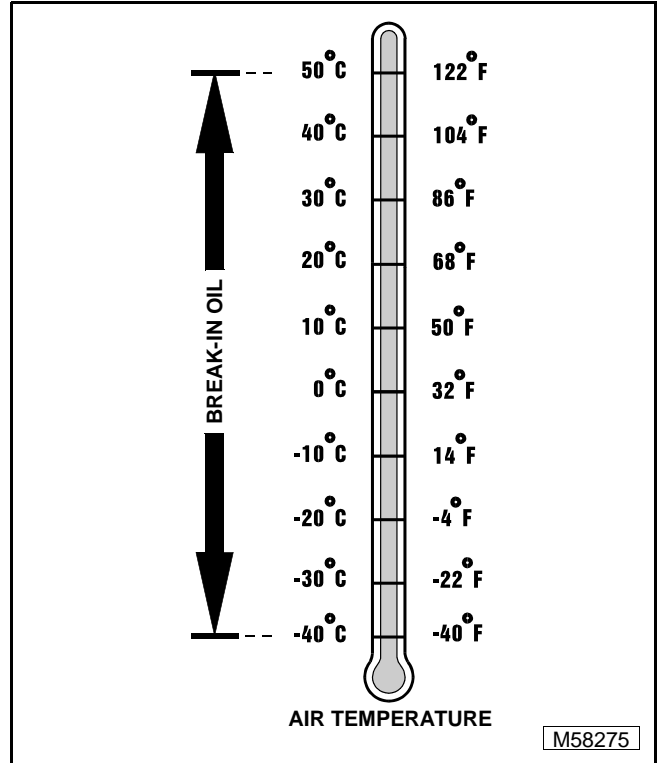

John Deere Dealers: You may want to cross-reference the following publications to recommend the proper oil for your customers:

- Module DX, ENOIL4 in JDS-G135;
- Section 530, Lubricants & Hydraulics, of the John Deere Merchandise Sales Guide.