

Product: John Deere 180B, 220B, 260B Walk-Behind Greensmower Service Repair Technical Manual
Full Download: <https://www.bobmanualstore.com/downloads/john-deere-180b-220b-260b-walk-behind-greensmower-service-repair-technical-manual/>

JOHN DEERE
WORLDWIDE COMMERCIAL & CONSUMER
EQUIPMENT DIVISION

Walk-Behind Greensmower
180B, 220B, and 260B

TM2004 DEC05

TECHNICAL MANUAL



JOHN DEERE

North American Version
Litho in U.S.A.

Sample manual. Download All 181 pages at:

<https://www.bobmanualstore.com/downloads/john-deere-180b-220b-260b-walk-behind-greensmower-service-repair-technical-manual/>

Product: John Deere 180B, 220B, 260B Walk-Behind Greensmower Service Repair Technical Manual
Full Download: <https://www.bobmanualstore.com/downloads/john-deere-180b-220b-260b-walk-behind-greensmower-service-repair-technical-manual/>

Sample manual. Download All 181 pages at:

<https://www.bobmanualstore.com/downloads/john-deere-180b-220b-260b-walk-behind-greensmower-service-repair-technical-manual/>

INTRODUCTION

Manual Description

This technical manual is written for an experienced technician and contains sections that are specifically for this product. It is a part of a total product support program.

The manual is organized so that all the information on a particular system is kept together. The order of grouping is as follows:

- Table of Contents
- Specifications and Information
- Identification Numbers
- Tools and Materials
- Component Location
- Schematics and Harnesses
- Theory of Operation
- Operation and Diagnostics
- Diagnostics
- Tests and Adjustments
- Repair
- Other

NOTE: Depending on the particular section or system being covered, not all of the above groups may be used.

The bleed tabs for the pages of each section will align with the sections listed on this page. Page numbering is consecutive from the beginning of the Safety section through the last section.

We appreciate your input on this manual. If you find any errors or want to comment on the layout of the manual please contact us.

Safety

Specifications and Information

Engine

Electrical

Power Train

Handlebar and Controls

Brakes

Cutting Unit

Miscellaneous

All information, illustrations and specifications in this manual are based on the latest information at the time of publication. The right is reserved to make changes at any time without notice.

COPYRIGHT© 2005
Deere & Co.
John Deere Worldwide Commercial and
Consumer Equipment Division
All rights reserved
Previous Editions
COPYRIGHT© 2002, 2003

INTRODUCTION

SAFETY

Recognize Safety Information



MIF

This is the safety-alert symbol. When you see this symbol on your machine or in this manual, be alert to the potential for personal injury.

Follow recommended precautions and safe servicing practices.

Understand Signal Words

A signal word - DANGER, WARNING, or CAUTION - is used with the safety-alert symbol. DANGER identifies the most serious hazards.

DANGER or WARNING safety signs are located near specific hazards. General precautions are listed on CAUTION safety signs. CAUTION also calls attention to safety messages in this manual.

Replace Safety Signs

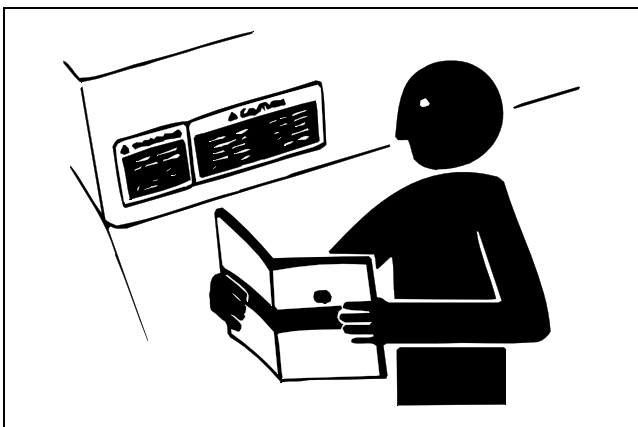

MIF

Replace missing or damaged safety signs. See the machine operator's manual for correct safety sign placement.

Be Prepared for Emergencies

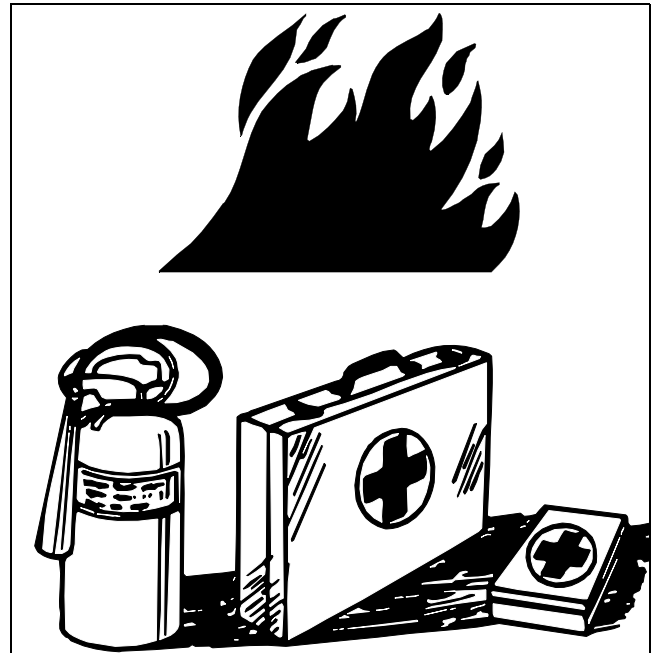

MIF

When you work around fuel, do not smoke or work near heaters or other fire hazards.

Store flammable fluids away from fire hazards. Do not incinerate or puncture pressurized containers.

Make sure machine is clean of trash, grease, and debris.

Do not store oily rags; they can ignite and burn spontaneously.

Be prepared if a fire starts.

Keep a first aid kit and fire extinguisher handy.

Keep emergency numbers for doctors, ambulance service, hospital, and fire department near your telephone.

Wear Protective Clothing

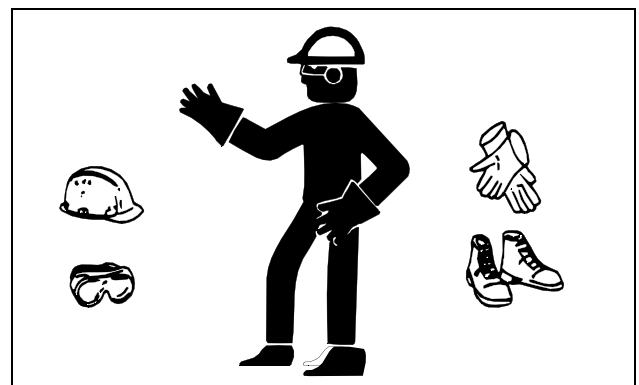

MIF

Wear close fitting clothing and safety equipment appropriate to the job.

SAFETY

Prolonged exposure to loud noise can cause impairment or loss of hearing. Wear a suitable hearing protective device such as earmuffs or earplugs to protect against objectionable or uncomfortable loud noises.

Operating equipment safely requires the full attention of the operator. Do not wear radio or music headphones while operating machine.

Service Machines Safely

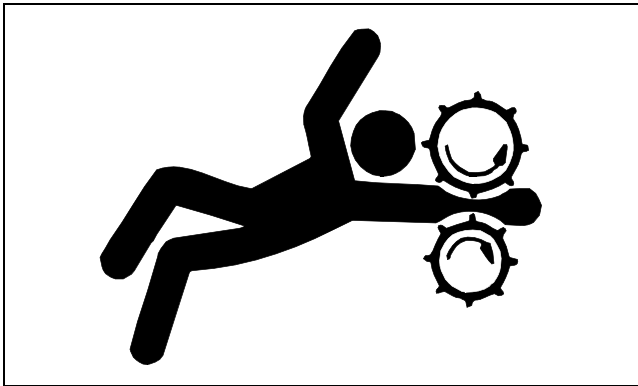

MIF

Tie long hair behind your head. Do not wear a necktie, scarf, loose clothing, or necklace when you work near machine tools or moving parts. If these items were to get caught, severe injury could result.

Remove rings and other jewelry to prevent electrical shorts and entanglement in moving parts.

Use Proper Tools

Use tools appropriate to the work. Makeshift tools and procedures can create safety hazards. Use power tools only to loosen threaded parts and fasteners. For loosening and tightening hardware, use the correct size tools. **DO NOT** use U.S. measurement tools on metric fasteners. Avoid bodily injury caused by slipping wrenches. Use only service parts meeting John Deere specifications.

Park Machine Safely

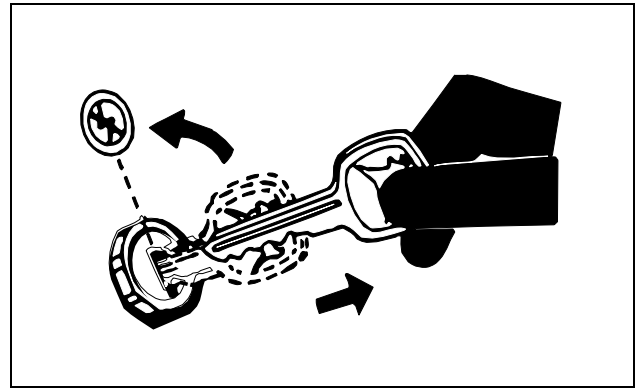

MIF

Before working on the machine:

1. Lower all equipment to the ground.
2. Stop the engine and remove the key.
3. Disconnect the battery ground strap.
4. Hang a "DO NOT OPERATE" tag in operator station.

Support Machine Properly and Use Proper Lifting Equipment

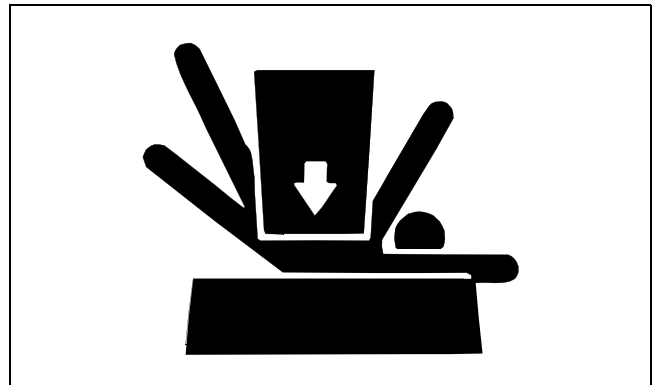

MIF

If you must work on a lifted machine or attachment, securely support the machine or attachment.

Do not support the machine on cinder blocks, hollow tiles, or props that may crumble under continuous load. Do not work under a machine that is supported solely by a jack. Follow recommended procedures in this manual.

Lifting heavy components incorrectly can cause severe injury or machine damage. Follow recommended procedure for removal and installation of components in the manual.

SAFETY

Work in Clean Area

Before starting a job:

1. Clean work area and machine.
2. Make sure you have all necessary tools to do your job.
3. Have the right parts on hand.
4. Read all instructions thoroughly; do not attempt shortcuts.

Illuminate Work Area Safely

Illuminate your work area adequately but safely. Use a portable safety light for working inside or under the machine. Make sure the bulb is enclosed by a wire cage. The hot filament of an accidentally broken bulb can ignite spilled fuel or oil.

Work in Ventilated Area

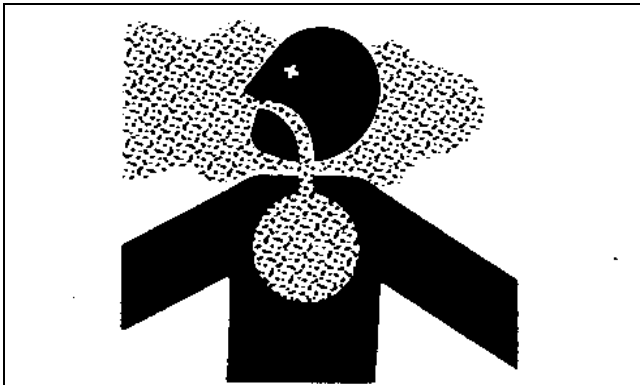

TS220

Engine exhaust fumes can cause sickness or death. If it is necessary to run an engine in an enclosed area, remove the exhaust fumes from the area with an exhaust pipe extension.

If you do not have an exhaust pipe extension, open the doors and get outside air into the area.

WARNING: California Proposition 65 Warning

Gasoline engine exhaust from this product contains chemicals known to the State of California to cause cancer, birth defects, or other reproductive harm.

Remove Paint before Welding or Heating

Avoid potentially toxic fumes and dust. Hazardous fumes can be generated when paint is heated by welding, soldering, or using a torch. Do all work outside or in a well ventilated area. Dispose of paint and solvent properly. Remove paint before welding or heating: If you sand or grind paint, avoid breathing the dust. Wear an approved

respirator. If you use solvent or paint stripper, remove stripper with soap and water before welding. Remove solvent or paint stripper containers and other flammable material from area. Allow fumes to disperse at least 15 minutes before welding or heating.

Avoid Harmful Asbestos Dust

Avoid breathing dust that may be generated when handling components containing asbestos fibers. Inhaled asbestos fibers may cause lung cancer.

Components in products that may contain asbestos fibers are brake pads, brake band and lining assemblies, clutch plates, and some gaskets. The asbestos used in these components is usually found in a resin or sealed in some way. Normal handling is not hazardous as long as airborne dust containing asbestos is not generated.

Avoid creating dust. Never use compressed air for cleaning. Avoid brushing or grinding material containing asbestos. When servicing, wear an approved respirator. A special vacuum cleaner is recommended to clean asbestos. If not available, apply a mist of oil or water on the material containing asbestos. Keep bystanders away from the area.

Service Tires Safely



MIF

Explosive separation of a tire and rim parts can cause serious injury or death.

Do not attempt to mount a tire unless you have the proper equipment and experience to perform the job. Always maintain the correct tire pressure. Do not inflate the tires above the recommended pressure. Never weld or heat a wheel and tire assembly. The heat can cause an increase in air pressure resulting in a tire explosion. Welding can structurally weaken or deform the wheel.

When inflating tires, use a clip-on chuck and extension hose long enough to allow you to stand to one side and NOT in front of or over the tire assembly. Use a safety cage if available.

Check wheels for low pressure, cuts, bubbles, damaged rims or missing lug bolts and nuts.

SAFETY

Avoid Injury from Rotating Blades, Augers, and PTO Shafts

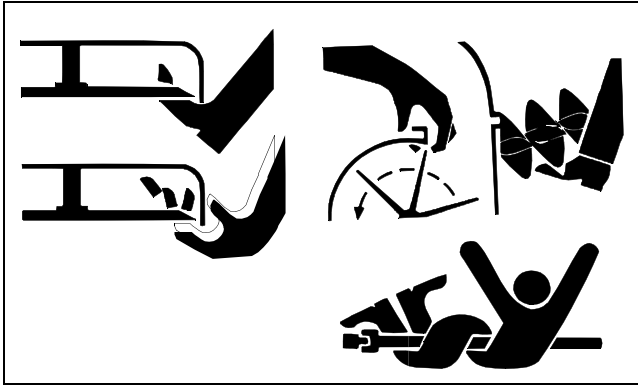

MIF

Keep hands and feet away while machine is running. Shut off power to service, lubricate or remove mower blades, augers or PTO shafts.

Handle Chemical Products Safely

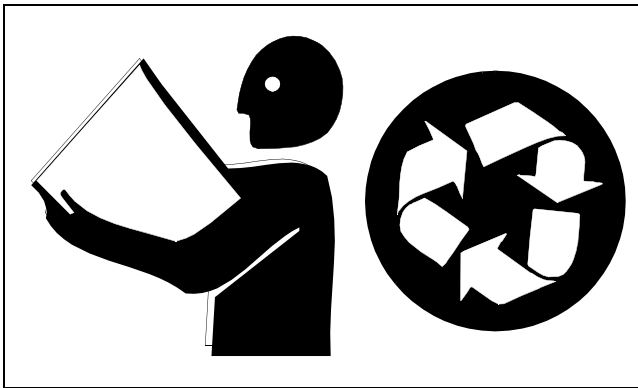

MIF

Direct exposure to hazardous chemicals can cause serious injury. Potentially hazardous chemicals used with John Deere equipment include such items as lubricants, coolants, paints, and adhesives.

A Material Safety Data Sheet (MSDS) provides specific details on chemical products: physical and health hazards, safety procedures, and emergency response techniques. Check the MSDS before you start any job using a hazardous chemical. That way you will know exactly what the risks are and how to do the job safely. Then follow procedures and recommended equipment.

Dispose of Waste Properly

Improperly disposing of waste can threaten the environment and ecology. Potentially harmful waste used with John Deere equipment includes such items as oil, fuel, coolant, brake fluid, filters, and batteries. Use leakproof containers when draining fluids. Do not use food or

beverage containers that may mislead someone into drinking from them. Do not pour waste onto the ground, down a drain, or into any water source. Inquire on the proper way to recycle or dispose of waste from your local environmental or recycling center, or from your John Deere dealer.

Live with Safety



MIF

Before returning machine to customer, make sure machine is functioning properly, especially the safety systems. Install all guards and shields.

SPECIFICATIONS & INFORMATION TABLE OF CONTENTS

Table of Contents

Specifications	7
Vehicle Specifications	7
Repair Information	9
Metric Fastener Torque Values	9
Metric Fastener Torque Values - Grade 7	10
Inch Fastener Torque Values	11
Oils and Lubricants	12
Engine Oil.....	12
Differential Gear Case Oil	12
Grease.....	12
Alternative Lubricants	13
Synthetic Lubricants	13
Lubricant Storage	13
Mixing of Lubricants	13
Gasoline	13
Using Proper Fuel	13
Serial Number Locations	14
Record Identification Numbers	14
Machine Identification Number.....	14
Engine Serial Number	14
Carburetor Identification Number	14
Operational Checkout	15
Operational Checkout Procedures	15
Engine Oil Level Check	15
Differential Gear Case Oil Level Check.....	15
Throttle Lever Check	16
Operator Presence Bail Check.....	16
Park Brake Check	17
Travel Clutch Check	17
Reel Clutch Check.....	18

SPECIFICATIONS & INFORMATION TABLE OF CONTENTS



SPECIFICATIONS & INFORMATION SPECIFICATIONS

Specifications

Vehicle Specifications

NOTE: Specifications and design subject to change without notice.

Engine

Make.....	Honda
Type.....	Gasoline, 25° inclined cylinder
Model.....	GX120 K1LJD2
Aspiration.....	Natural
Cylinders.....	1
Displacement.....	118 cm ³ (7.2 cu in.)
Stroke/Cycle.....	4 cycle
Bore.....	60 mm (2.4 in.)
Stroke.....	42 mm (1.7 in.)
Compression Ratio.....	8.5:1
Slow Idle.....	1400 +220/-150 rpm
180B Fast Idle.....	3000 ± 150 rpm
220B and 260B Fast Idle.....	3450 ± 150 rpm
Timing.....	25° BTDC
Valving.....	Overhead valves
Lubrication.....	Splash
Cooling System.....	Forced air
Air Cleaner.....	Dual-element (silent) type
Carburetor.....	Float-type
Muffler.....	In-line
Engine Oil Capacity.....	0.6 L (0.63 qt)
Type of Starter.....	Recoil
Weight.....	15.5 kg (34.2 lb)

Fuel System

Fuel Tank Location.....	On engine
Fuel Tank Capacity.....	2.5 L (0.66 gal)
Fuel (Minimum Octane).....	Unleaded gasoline, 87 octane
Fuel Delivery.....	Gravity
Carburetor.....	Float-type side draft
Fuel Filter.....	Screen

Electrical

Ignition.....	Transistorized magneto
---------------	------------------------

Drive Train/Traveling Device

Traction Roller.....	Smooth surface, dual aluminium
Forward Traveling Speed.....	9.2 km/h (5.5 mph)
Mow Traveling Speed.....	5.5 km/h (3.4 mph)
Front Roller.....	Machined steel, solid or grooved

SPECIFICATIONS & INFORMATION SPECIFICATIONS

Brakes

Park Brake Band type, lever activated

Cutting Unit

180B Cutting Width 457 mm (18 in.)
220B Cutting Width 559 mm (22 in.)
260B Cutting Width 660 mm (26 in.)
Cutting Height (Min, Standard 3.0 mm Bed Knife) 3.2 mm (1/8 in.)
Cutting Height (Min, Optional 2.5 mm Bed Knife) 2.8 mm (7/64 in.)
Cutting Height (Min, Optional 2.0 mm Bed Knife) 2.0 mm (5/64 in.)
Cutting Height (Max) 22.2 mm (7/8 in.)
Frequency of Clip (Standard) 4.62 mm (0.182 in.)
Frequency of Clip (Optional) 4.04 mm (0.159 in.)
Reel Diameter 127 mm (5 in.)
Reel Number of Blades (Standard) 11
Reel Number of Blades (Optional - 220B) 9
Reel Number of Blades (Optional - 260B) 7
Reel Material Heat treated special alloy steel
Grass Catcher Rotational molded polypropylene

Weights and Dimensions

Weight (Less GTC and Wheels, with Grass Catcher)

180B 91 kg (201 lb)
220B 100 kg (220 lb)
260B 107 kg (236 lb)

Width

180B 838 mm (33 in.)
220B 940 mm (37 in.)
260B 1041 mm (41 in.)
Length 1244 mm (49 in.)
Height 1016 mm (41 in.)







Wheels and Tires

Size 4.1/3.5-6 (2 pr) tubeless
Pressure 125-140 kPa (18-20 psi)

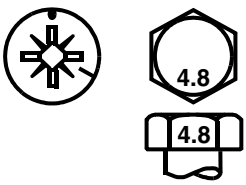
SPECIFICATIONS & INFORMATION REPAIR INFORMATION

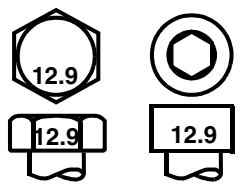
Repair Information

Metric Fastener Torque Values

Property Class and Head Markings	4.8 	8.8 9.8 	10.9 	12.9 
Property Class and Nut Markings	5 	10 	10 	12 

MIF (TS1163)

	Class 4.8				Class 8.8 or 9.8				Class 10.9				Class 12.9			
	Lubricated ¹		Dry ^a		Lubricated ^a		Dry ^a		Lubricated ^a		Dry ^a		Lubricated ^a		Dry ^a	
SIZE	N•m	lb-ft	N•m	lb-ft	N•m	lb-ft	N•m	lb-ft	N•m	lb-ft	N•m	lb-ft	N•m	lb-ft	N•m	lb-ft
M6	4.8	3.5	6	4.5	9	6.5	11	8.5	13	9.5	17	12	15	11.5	19	14.5
M8	12	8.5	15	11	22	16	28	20	32	24	40	30	37	28	47	35
M10	23	17	29	21	43	32	55	40	63	47	80	60	75	55	95	70
M12	40	29	50	37	75	55	95	70	110	80	140	105	130	95	165	120
M14	63	47	80	60	120	88	150	110	175	130	225	165	205	150	260	109
M16	100	73	125	92	190	140	240	175	275	200	350	225	320	240	400	300
M18	135	100	175	125	260	195	330	250	375	275	475	350	440	325	560	410
M20	190	140	240	180	375	275	475	350	530	400	675	500	625	460	800	580
M22	260	190	330	250	510	375	650	475	725	540	925	675	850	625	1075	800
M24	330	250	425	310	650	475	825	600	925	675	1150	850	1075	800	1350	1000
M27	490	360	625	450	950	700	1200	875	1350	1000	1700	1250	1600	1150	2000	1500
M30	675	490	850	625	1300	950	1650	1200	1850	1350	2300	1700	2150	1600	2700	2000
M33	900	675	1150	850	1750	1300	2200	1650	2500	1850	3150	2350	2900	2150	3700	2750
M36	1150	850	1450	1075	2250	1650	2850	2100	3200	2350	4050	3000	3750	2750	4750	3500

1. "Lubricated" means coated with a lubricant such as engine oil, or fasteners with phosphate and oil coatings. "Dry" means plain or zinc plated (yellow dichromate - Specification JDS117) without any lubrication.

DO NOT use these hand torque values if a different torque value or tightening procedure is given for a specific application. Torque values listed are for general use only and include a ±10% variance factor. Check tightness of fasteners periodically. DO NOT use air powered wrenches.

Shear bolts are designed to fail under predetermined loads. Always replace shear bolts with identical grade.

Fasteners should be replaced with the same class. Make sure fastener threads are clean and that you properly start

thread engagement. This will prevent them from failing when tightening.

When bolt and nut combination fasteners are used, torque values should be applied to the NUT instead of the bolt head.

Tighten toothed or serrated-type lock nuts to the full torque value.

Reference: JDS-G200.







SPECIFICATIONS & INFORMATION REPAIR INFORMATION

Metric Fastener Torque Values - Grade 7

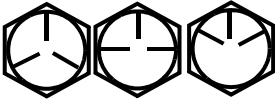
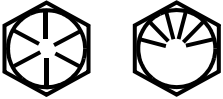
Size	Steel or Gray Iron Torque		Aluminum Torque	
	N•m	lb-ft	N•m	lb-ft
M6	11	8	8	6
M8	24	18	19	14
M10	52	38	41	30
M12	88	65	70	52
M14	138	102	111	82
M16	224	165	179	132

SPECIFICATIONS & INFORMATION REPAIR INFORMATION

Inch Fastener Torque Values

SAE Grade and Head Markings	1 or 2 ^a No Marks 	5 5.1 5.2 	8 8.2 
SAE Grade and Nut Markings	2 No Marks 	5  	8  

MIF (TS1162)

SIZE	Grade 1				Grade 2 ¹				Grade 5, 5.1 or 5.2				Grade 8 or 8.2			
	Lubricated ²		Dry ^b		Lubricated ^b		Dry ^b		Lubricated ^b		Dry ^b		Lubricated ^b		Dry ^b	
	N•m	lb-ft	N•m	lb-ft	N•m	lb-ft	N•m	lb-ft	N•m	lb-ft	N•m	lb-ft	N•m	lb-ft	N•m	lb-ft
1/4	3.7	2.8	4.7	3.5	6	4.5	7.5	5.5	9.5	7	12	9	13.5	10	17	12.5
5/16	7.7	5.5	10	7	12	9	15	11	20	15	25	18	28	21	35	26
3/8	14	10	17	13	22	16	27	20	35	26	44	33	50	36	63	46
7/16	22	16	28	20	35	26	44	32	55	41	70	52	80	58	100	75
1/2	33	25	42	31	53	39	67	50	85	63	110	80	120	90	150	115
9/16	48	36	60	45	75	56	95	70	125	90	155	115	175	130	225	160
5/8	67	50	85	62	105	78	135	100	170	125	215	160	215	160	300	225
3/4	120	87	150	110	190	140	240	175	300	225	375	280	425	310	550	400
7/8	190	140	240	175	190	140	240	175	490	360	625	450	700	500	875	650
1	290	210	360	270	290	210	360	270	725	540	925	675	1050	750	1300	975
1-1/8	470	300	510	375	470	300	510	375	900	675	1150	850	1450	1075	1850	1350
1-1/4	570	425	725	530	570	425	725	530	1300	950	1650	1200	2050	1500	2600	1950
1-3/8	750	550	950	700	750	550	950	700	1700	1250	2150	1550	2700	2000	3400	2550
1-1/2	1000	725	1250	925	990	725	1250	930	2250	1650	2850	2100	3600	2650	4550	3350

1. "Grade 2" applies for hex cap screws (not hex bolts) up to 152 mm (6-in.) long. "Grade 1" applies for hex cap screws over 152 mm (6-in.) long, and for all other types of bolts and screws of any length.
2. "Lubricated" means coated with a lubricant such as engine oil, or fasteners with phosphate and oil coatings. "Dry" means plain or zinc plated (yellow dichromate - Specification JDS117) without any lubrication.

DO NOT use these hand torque values if a different torque value or tightening procedure is given for a specific application. Torque values listed are for general use only and include a ±10% variance factor. Check tightness of fasteners periodically. DO NOT use air powered wrenches.

Shear bolts are designed to fail under predetermined loads. Always replace shear bolts with identical grade.

Fasteners should be replaced with the same grade. Make sure fastener threads are clean and that you properly start

thread engagement. This will prevent them from failing when tightening.

When bolt and nut combination fasteners are used, torque values should be applied to the NUT instead of the bolt head.

Tighten toothed or serrated-type lock nuts to the full torque value.

Reference: JDS-G200.

SPECIFICATIONS & INFORMATION OILS AND LUBRICANTS

Oils and Lubricants

Engine Oil

Use oil viscosity based on the expected air temperature range during the period between oil changes.

The following John Deere oils are preferred:

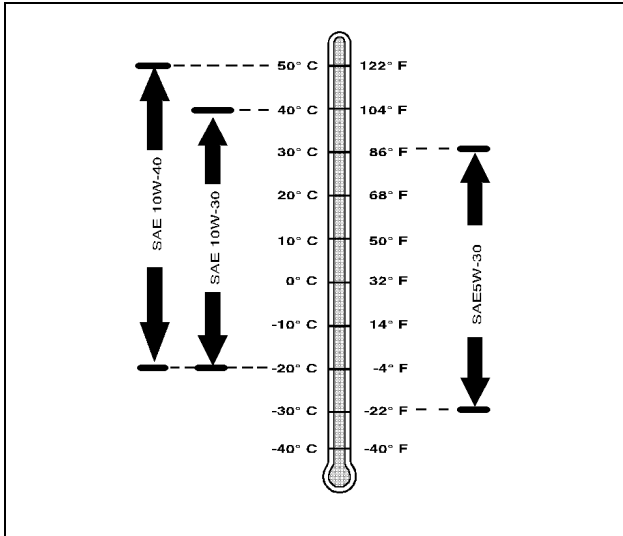

MX4888

- TURF-GARD®
- PLUS-4®

Other oils may be used if above John Deere oils are not available, provided they meet the following specification:

- API Service Classification SG or higher

Differential Gear Case Oil

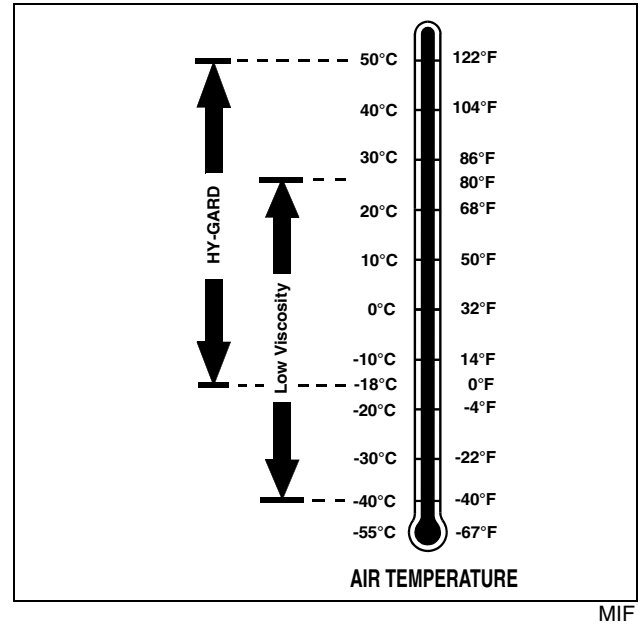

MIF

NOTE: Transaxle is filled with John Deere HY-GARD® (J20C) transmission oil at the factory. Do not mix oils.

Use only HY-GARD® (J20C) transmission oil.

Do not use type "F" automatic transmission fluid.

John Deere HY-GARD® (J20C) transmission oil is specially formulated to provide maximum protection against mechanical wear, corrosion, and foaming.

Grease

IMPORTANT: Avoid damage! Use recommended John Deere greases to avoid component failure and premature wear.

The recommended John Deere greases are effective within an average air temperature range of -29 to 135 degrees C (-20 to 275 degrees F).

If operating outside that temperature range, contact your Servicing dealer for a special-use grease.

The following greases are preferred (this may change for high speed applications such as cutting units):

- John Deere Multi-Purpose SD Polyurea Grease

If not using any of the preferred greases, be sure to use a general all-purpose grease with an NLGI grade No. 2 rating.

Wet or high speed conditions may require use of a special-use grease. Contact your Servicing dealer for information.

SPECIFICATIONS & INFORMATION GASOLINE

Alternative Lubricants

Conditions in certain geographical areas outside the United States and Canada may require different lubricant recommendations than the ones printed in this technical manual or the operator's manual. Consult with your John Deere Dealer, or Sales Branch, to obtain the alternative lubricant recommendations.

IMPORTANT: Avoid damage! Use of alternative lubricants could cause reduced life of the component.

If alternative lubricants are to be used, it is recommended that the factory fill be thoroughly removed before switching to any alternative lubricant.

Synthetic Lubricants

Synthetic lubricants may be used in John Deere equipment if they meet the applicable performance requirements (industry classification and/or military specification) as shown in this manual.

The recommended air temperature limits and service or lubricant change intervals should be maintained as shown in the operator's manual.

Avoid mixing different brands, grades, or types of oil. Oil manufacturers blend additives in their oils to meet certain specifications and performance requirements. Mixing different oils can interfere with the proper functioning of these additives and degrade lubricant performance.

Lubricant Storage

All machines operate at top efficiency only when clean lubricants are used. Use clean storage containers to handle all lubricants. Store them in an area protected from dust, moisture, and other contamination. Store drums on their sides. Make sure all containers are properly marked as to their contents. Dispose of all old, used containers and their contents properly.

Mixing of Lubricants

In general, avoid mixing different brands or types of lubricants. Manufacturers blend additives in their lubricants to meet certain specifications and performance requirements. Mixing different lubricants can interfere with the proper functioning of these additives and lubricant properties which will downgrade their intended specified performance.

Gasoline

Using Proper Fuel

Use regular grade unleaded fuel with an octane rating of 87 octane or higher. Fuel blends containing up to 10% ethanol or up to 15% MTBE reformulated fuel are acceptable. Do not use fuel or additives containing methanol as engine damage can occur.

Always use fresh, clean fuel that is purchased in a quantity that can be used within approximately 30 days, or add fuel stabilizer.

Fuel is blended to give best seasonal performance. To avoid engine performance problems such as hard starting or vapor lock, use in-season fuel. Use fuel during warm weather that was purchased during that season, and use fuel during cold weather that was purchased during that season.

Fuel can become stale in machines with engines that are used seasonally or infrequently during a season. Stale fuel can produce varnish and plug carburetor or injector components which can affect engine performance.

Keep fuel storage container tightly covered and in a cool area out of direct sunlight. Fuel can break down and degrade if not sealed properly or exposed to sun and heat.

Condensation may collect in the fuel tank because of a variety of operating or environmental conditions and, over time, may affect your machine's operation. Fill fuel tank at the end of daily use and store fuel in plastic containers to reduce condensation.

For best year-round performance and fuel-handling, add stabilizer to fuel immediately after fuel purchase. Such practice helps prevent engine performance problems and allows fuel storage in the machine all year without draining.

SPECIFICATIONS & INFORMATION SERIAL NUMBER LOCATIONS

Serial Number Locations

Record Identification Numbers

When ordering parts or submitting a warranty claim, it is **IMPORTANT** that the machine product identification and component serial numbers are included.

The location of the machine identification number and component serial numbers are shown.

Machine Identification Number



MX11251

Carburetor Identification Number

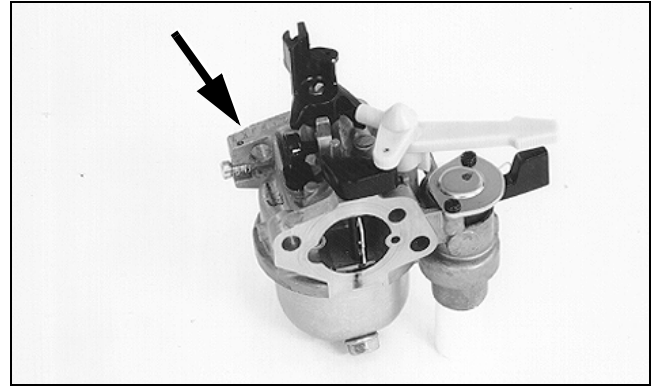

M83820

Engine Serial Number

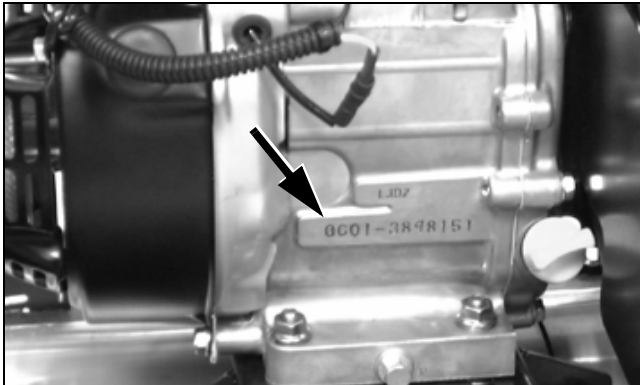

MX6042

Operational Checkout

Operational Checkout Procedures

The procedures covered in this group are used to give a quick checkout of all the systems and components on the unit. These checkouts should be run to ensure proper operation after any extended storage, when the unit comes in for service and after repairs have been made on the unit. They can also be helpful in determining the value of the unit at trade-in time. The unit should be placed on a level surface to run checkout. All checkouts should be done and all the steps of each checkout should be followed.

Each checkout list:

- Conditions - How the unit should be set up for the checkout.
- Procedure - The specific action to be done.
- Normal - What should happen, or be heard, or seen.
- If Not Normal - Where to go if other tests or adjustments are needed.

When performing the checkout, be sure to set your machine up to the test conditions listed and follow the sequence carefully. The "Normal" paragraph gives the result that should happen when performing the checkout. If the results are not normal, follow the instructions listed in the "If Not Normal" paragraph to determine the cause and repair the malfunction.

Engine Oil Level Check

Conditions

- Engine stopped.
- Machine parked on level surface.
- RUN/OFF switch in OFF position.
- Engine oil cold.
- Block placed under front roller to level machine/engine.

Procedure

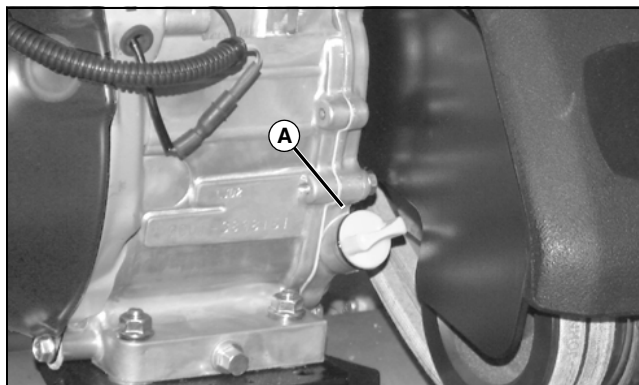

MX6043

1. Before removing dipstick (A), clean around dipstick.
2. Remove dipstick and check oil level.

Normal

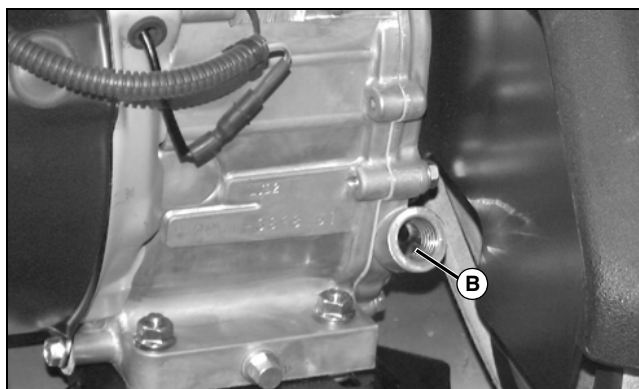

MX6019

Oil level (B) is to the outer edge of the oil filler neck.

If Not Normal

Oil level is below outer edge of oil filler neck: add oil. (See "Engine Oil" on page 12.)

Differential Gear Case Oil Level Check

Conditions

- Engine stopped.
- Machine parked on level surface.
- RUN/OFF switch in OFF position.
- Engine oil cold.
- Block placed under front roller to level machine/differential gear case.

SPECIFICATIONS & INFORMATION OPERATIONAL CHECKOUT

Procedure

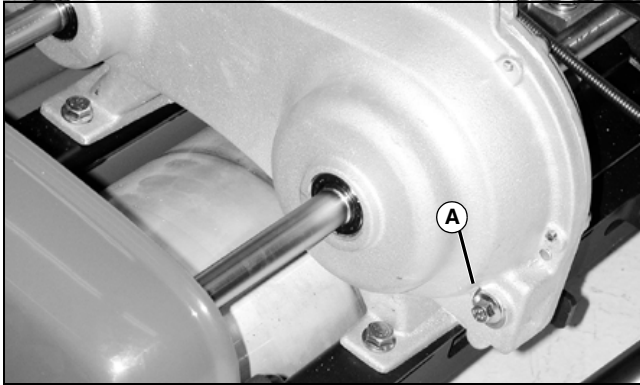

1. Remove drain plug (A).
2. Observe oil level inside gear case.

Normal

Oil level is up to bottom of drain hole in gear case.

If Not Normal

- Oil level is below bottom of hole: add oil. (See "Differential Gear Case Oil" on page 12.)
- Oil level is above hole: drain excess oil until level is up to bottom of hole in gear case.

Throttle Lever Check

Conditions

- Machine parked on level surface.
- Operator presence bail engaged.
- Travel clutch disengaged.
- Park brake engaged.

Procedure

1. Start engine and run at slow idle (1400 +220/-150 rpm).



2. Move throttle (A) from SLOW to FAST to SLOW positions.

Normal

- Engine must accelerate and decelerate SMOOTHLY without hesitation.
- Throttle lever should move freely, yet hold desired position.

If Not Normal

- Adjust throttle cable. (See "Throttle Cable Check and Adjustment" on page 36.)
- Adjust throttle lever tension. (See "Throttle Lever Tension Adjustment" on page 124.)

Operator Presence Bail Check

Conditions

- Engine running.
- Reel clutch in MOW position.
- Park brake disengaged.

Procedure



CAUTION: Avoid injury! Perform this check in a large, flat and open area away from people and/or stationary objects or structures.



1. Hold operator presence bail (B) against handlebar.
2. Engage travel clutch lever (A).

Normal

- Transport drive (traction roller/transport wheels) should engage.
- Reel drive should engage.

SPECIFICATIONS & INFORMATION OPERATIONAL CHECKOUT

If Not Normal

- Adjust operator presence bail. (See “Operator Presence Bail Adjustment” on page 124.)
- Adjust drive belt tension. (See “Drive Belt Tension Check and Adjustment” on page 98.)
- Repair power train as necessary. (See “Repair” on page 104.)

Procedure

Release operator presence bail.

Normal

- Transport drive (traction roller/transport wheels) should stop.
- Reel drive should stop.

If Not Normal

Adjust belt guide. (See “Drive Belt Guide Adjustment” on page 100.)

Park Brake Check

Conditions

- Engine running.
- Reel clutch in OFF position.
- Travel clutch disengaged.

Procedure

- Engage park brake.
- Run engine at low idle.
- Engage operator presence bail.
- Slowly engage travel clutch lever.

Result: Engine should stall with no movement of the mower.

If Not Normal

Adjust park brake. (See “Park Brake Check and Adjustment” on page 137.)

Travel Clutch Check

Conditions

- Engine running.
- Reel clutch in OFF position.
- Park brake disengaged.
- Operator presence bail engaged.

Procedure



CAUTION: Avoid injury! Perform this check in a large, flat and open area away from people and/or stationary objects or structures.



MX11234

Engage travel clutch lever (A).

Normal

Transport drive (traction roller/transport wheels) should engage.

If Not Normal

- Adjust drive belt tension. (See “Drive Belt Tension Check and Adjustment” on page 98.)
- Repair power train as necessary. (See “Repair” on page 104.)

SPECIFICATIONS & INFORMATION OPERATIONAL CHECKOUT

Reel Clutch Check

Conditions

- Engine stopped.
- Machine parked on level surface.
- Park brake disengaged.

Procedure



CAUTION: Avoid injury! Perform this check in a large, flat and open area away from people and/or stationary objects or structures.

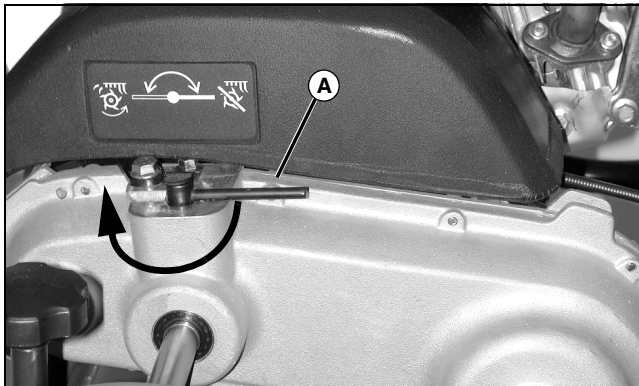

MX11247

1. Place reel clutch lever (A) in MOW position.
2. Start engine and run at slow idle (1400 +220/-150 rpm).



MX11234

3. Hold operator presence bail (B) against handlebar.
4. Engage travel clutch lever (C).

Normal

- Transport drive (traction roller/transport wheels) should engage.
- Reel drive should engage.

If Not Normal

- Adjust drive belt tension. (See “Drive Belt Tension Check and Adjustment” on page 98.)
- Repair power train as necessary. (See “Repair” on page 104.)

Procedure

1. Release operator presence bail.

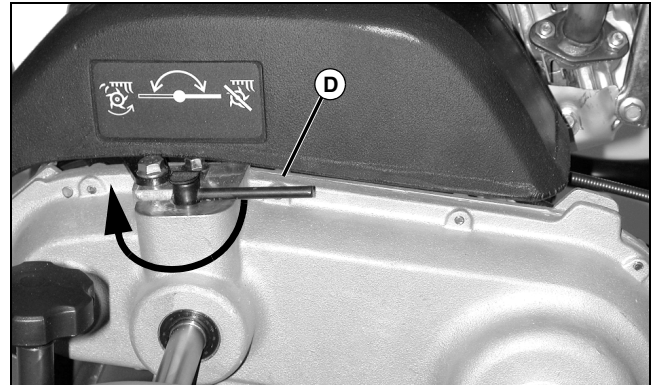

MX11247

2. Place reel clutch lever (D) in MOW position.



MX11234

3. Hold operator presence bail (E) against handlebar.
4. Engage travel clutch lever (F).

Normal

- Transport drive (traction roller/transport wheels) should engage.
- Reel drive should not engage.

If Not Normal

- Adjust drive belt tension. (See “Drive Belt Tension Check and Adjustment” on page 98.)
- Repair power train as necessary. (See “Repair” on page 104.)

ENGINE TABLE OF CONTENTS

Table of Contents

Specifications21

General Specifications21

Test and Adjustment Specifications21

Repair Specifications.....21

Tools and Materials25

Special or Essential Tools25

Other Materials.....25

Service Parts Kits25

Component Location and Operation26

External Engine Components.....26

Internal Engine Components.....28

Lubrication System Operation29

Cooling System Operation30

Diagnostics32

Engine Diagnosis32

Tests and Adjustments36

Throttle Cable Check and Adjustment.....36

Slow Idle Speed Adjustment36

Governor and Fast Idle Speed Adjustment ..36

Cylinder Compression Pressure Test.....37

Valve Clearance Check and Adjustment.....38

Spark Test.....39

Spark Plug Gap Adjustment.....39

Repair.....41

Fuel Tank Removal/Installation41

Fuel Filter Removal and Installation42

Throttle Cable Removal and Installation42

Muffler Removal and Installation42

Engine Removal and Installation.....43

Air Cleaner Assembly Removal and
Installation44

Service of Air Cleaner45

Throttle Plate Assembly Removal and
Installation45

Carburetor Removal and Installation.....46

Carburetor Disassembly and Assembly48

Carburetor Clean and Inspect49

Pilot Screw and Limiter Cap Replacement...49

Float Level Adjustment.....50

Blower Housing Assembly Removal and
Installation50

Recoil Starter Removal/Installation51

Recoil Starter Disassembly and Inspection..51

Recoil Starter Assembly52

Ignition Coil Removal and Installation..... 53

Air Gap Adjustment..... 54

Ignition Coil Test..... 54

Flywheel Removal and Installation 55

Rocker Arm Cover Removal and
Installation..... 55

Cylinder Head and Valves Removal and
Installation..... 56

Cylinder Head and Valves Disassembly and
Assembly 57

Cylinder Head and Valves Inspection..... 57

Valve Guide Replacement..... 59

Analyze Valves 60

Recondition Valve Seats..... 61

Lap Valves..... 62

Crankcase Cover Removal and Installation. 62

Bearing and Oil Seal Replacement..... 63

Camshaft and Tappets Removal and
Installation..... 63

Camshaft and Tappets Inspection 64

Piston and Connecting Rod Removal..... 65

Piston and Connecting Rod Installation..... 65

Piston and Connecting Rod Disassembly.... 66

Piston and Connecting Rod Assembly 66

Piston and Connecting Rod Inspection..... 67

Check Connecting Rod Side Play..... 70

Check Connecting Rod-to-Crankshaft
Clearance 70

Check Piston Ring End Gap..... 71

Analyze Piston Ring Wear 71

Analyze Piston Wear 72

Crankshaft Removal and Installation 73

Crankshaft Inspection 74

Timing/Governor Gear Replacement..... 74

Analyze Crankshaft and
Connecting Rod Wear 74

Cylinder Block Inspection 75

Bearing Inspection and Replacement..... 76

Oil Seal Replacement..... 76

Deglaze Cylinder Bore..... 76

Rebore Cylinder Block..... 77

Governor Removal and Installation 77

ENGINE TABLE OF CONTENTS



ENGINE SPECIFICATIONS

Specifications

General Specifications

Make	Honda
Type	Gasoline, 25° inclined cylinder
Model	GX120 K1LJD2
Aspiration	Natural
Cylinders	1
Displacement	118 cm ³ (7.2 cu in.)
Stroke/Cycle	4 cycle
Bore	60 mm (2.4 in.)
Stroke	42 mm (1.7 in.)
Compression Ratio	8.5:1
Valving	Overhead valves
Lubrication	Splash
Cooling System	Forced air
Air Cleaner	Dual-element (silent) type
Carburetor	Float-type
Muffler	In-line
Engine Oil Capacity	0.6 L (0.63 qt)
Type of Starter	Recoil
Weight	15.5 kg (34.2 lb)

Test and Adjustment Specifications

Fast Idle

180B	3000 ± 150 rpm
220B and 260B	3450 ± 150 rpm

Slow Idle 1400 +200/-150 rpm

Cylinder Compression Pressure	586-834 kPa (85-121 psi)
Intake Valve Clearance	0.15 ± 0.02 mm (0.006 ± 0.001 in.)
Exhaust Valve Clearance	0.20 ± 0.02 mm (0.008 ± 0.001 in.)
Spark Plug Gap	0.7-0.8 mm (0.028-0.031 in.)

Ignition Coil

Air Gap	0.4 ± 0.2 mm (0.016 ± 0.008 in.)
Resistance (Primary Side)	0.8-1.0 ohm
Resistance (Secondary Side)	5.9-7.1 k-ohm

Repair Specifications

Engine

Engine Oil Capacity	0.6 L (0.63 qt)
Oil Drain Plug Torque	18 N•m (156 lb-in.)

ENGINE SPECIFICATIONS

Fuel Tank

Capacity	2.5 L (0.66 gal)
Mounting Cap Screw Torque	10 N•m (84 lb-in.)
Mounting Flange Nut Torque	10 N•m (84 lb-in.)
Fuel Filter Torque	2 N•m (17 lb-in.)

Muffler

Mounting Nut Torque	24 N•m (204 lb-in.)
---------------------	---------------------

Air Cleaner Assembly

Air Cleaner Wing Nut Torque	9 N•m (78 lb-in.)
Air Cleaner Housing Flange Nut Torque	8.5 N•m (73 lb-in.)

Carburetor

Float Height	13.7 mm (0.54 in.)
Sediment Cup Torque	4 N•m (36 lb-in.)

Flywheel

Flange Nut Torque	75 N•m (54 lb-ft)
-------------------	-------------------

Cylinder Head

Initial Cap Screw Torque	12 N•m (102 lb-in.)
Final Cap Screw Torque	24 N•m (204 lb-in.)
Maximum Cylinder Head Distortion	0.10 mm (0.004 in.)
Rocker Arm Pivot Bolt Torque	24 N•m (204 lb-in.)
Rocker Arm Pivot Lock Nut Torque	10 N•m (84 lb-in.)
Standard Valve Guide ID	5.50 mm (0.217 in.)
Valve Guide ID Wear Limit	5.572 mm (0.2194 in.)
Standard Valve Seat Width	0.8 mm (0.03 in.)
Valve Seat Width Wear Limit	2.0 mm (0.08 in.)

Valve Spring

Standard Free Length	30.5 mm (1.20 in.)
Free Length Wear Limit	29.5 mm (1.16 in.)

Intake Valve

Stem OD Standard	5.48 mm (0.216 in.)
Stem OD Wear Limit	5.318 mm (0.2094 in.)
Maximum Valve Stem Out-of-Round	0.03 mm (0.001 in.)
Head Diameter	22 mm (0.87 in.)

Exhaust Valve

Standard Stem OD	5.44 mm (0.214 in.)
Stem OD Wear Limit	5.275 mm (0.2077 in.)
Maximum Valve Stem Out-of-Round	0.03 mm (0.001 in.)
Head Diameter	19 mm (0.75 in.)

ENGINE SPECIFICATIONS

Crankcase Cover

Cap Screw Torque	12 N•m (108 lb-in.)
Camshaft Holder ID Standard	14.0 mm (0.55 in.)
Camshaft Holder ID Wear Limit	14.048 mm (0.5531 in.)

Piston

Connecting Rod Cap Screw Torque	12 N•m (9 lb-ft)
Standard Piston Skirt Standard OD	59.985 mm (2.3616 in.)
Standard Piston Skirt OD Wear Limit	59.845 mm (2.3561 in.)
0.25 mm (0.010 in.) Oversize Piston Skirt Standard OD	60.235 mm (2.3716 in.)
0.25 mm (0.010 in.) Oversize Piston Skirt OD Wear Limit	60.095 mm (2.3661 in.)
0.50 mm (0.020 in.) Oversize Piston Skirt Standard OD	60.485 mm (2.38 in.)
0.50 mm (0.020 in.) Oversize Piston Skirt OD Wear Limit	60.345 mm (2.3761 in.)
Piston-to-Cylinder Standard Clearance	0.015-0.050 mm (0.0006-0.0020 in.)
Piston-to-Cylinder Clearance Wear Limit	0.12 mm (0.005 in.)
1st and 2nd Compression Piston Ring Standard Thickness	1.5 mm (0.06 in.)
1st and 2nd Compression Piston Ring Thickness Wear Limit	1.37 mm (0.054 in.)
Oil Control Piston Ring Standard Thickness	2.5 mm (0.10 in.)
Oil Control Piston Ring Thickness Wear Limit	2.37 mm (0.093 in.)
Piston Ring Groove Standard Side Clearance	0.015-0.045 mm (0.0006-0.0018 in.)
Piston Ring Groove Side Clearance Wear Limit	0.15 mm (0.006 in.)
Top and 2nd Piston Ring Standard End Gap	0.2-0.4 mm (0.008-0.016 in.)
Top and 2nd Piston Ring End Gap Wear Limit	1.0 mm (0.04 in.)
Oil Control Piston Ring Standard End Gap	0.15-0.35 mm (0.006-0.014 in.)
Oil Control Piston Ring End Gap Wear Limit	1.0 mm (0.04 in.)
Piston Pin Standard OD	13.0 mm (0.51 in.)
Piston Pin OD Wear Limit	12.954 mm (0.510 in.)
Piston Pin Bore Standard ID	13.002 mm (0.5119 in.)
Piston Pin Bore ID Wear Limit	13.048 mm (0.5137 in.)
Piston-to-Piston Pin Bore Standard Clearance	0.002-0.014 mm (0.0001-0.0006 in.)
Piston-to-Piston Pin Bore Clearance Wear Limit	0.08 mm (0.003 in.)

Connecting Rod

Piston Pin Bushing Standard ID	13.005 mm (0.512 in.)
Piston Pin Bushing ID Wear Limit	13.07 mm (0.515 in.)
Standard Crankshaft Bearing Standard ID	26.02 mm (1.024 in.)
Standard Crankshaft Bearing ID Wear Limit	26.066 mm (1.0262 in.)
0.25 mm (0.010 in.) Undersize Crankshaft Bearing Standard ID	25.770-25.783 mm (1.0146-1.0151 in.)
0.25 mm (0.010 in.) Undersize Crankshaft Bearing ID Wear Limit	25.816 mm (1.0164 in.)
Connecting Rod-to-Crankshaft Journal Standard Clearance	0.040-0.063 mm (0.0016-0.0025 in.)
Connecting Rod-to-Crankshaft Journal Clearance Wear Limit	0.12 mm (0.005 in.)
Connecting Rod-to-Crankshaft Standard Side Clearance	0.1-0.7 mm (0.004-0.028 in.)
Connecting Rod-to-Crankshaft Side Clearance Wear Limit	1.1 mm (0.043 in.)

ENGINE SPECIFICATIONS

Camshaft

Cam Lobe Standard Height (Intake)	27.7 mm (1.09 in.)
Cam Lobe Height Wear Limit (Intake)	27.45 mm (1.081 in.)
Cam Lobe Standard Height (Exhaust)	27.75 mm (1.093 in.)
Cam Lobe Height Wear Limit (Exhaust)	27.50 mm (1.083 in.)
Journal Standard OD	13.984 mm (0.5506 in.)
Journal OD Wear Limit	13.916 mm (0.5479 in.)

Crankshaft

Connecting Rod Journal Standard OD	25.98 mm (1.023 in.)
Connecting Rod Journal OD Wear Limit	25.92 mm (1.020 in.)

Cylinder Block

Standard Piston Cylinder Bore Standard ID	60.0 mm (2.36 in.)
Standard Piston Cylinder Bore ID Wear Limit	60.165 mm (2.3687 in.)
0.25 mm (0.010 in.) Oversize Piston Cylinder Bore Standard ID	60.25 mm (2.37 in.)
0.25 mm (0.010 in.) Oversize Piston Cylinder Bore ID Wear Limit	60.415 mm (2.3787 in.)
0.50 mm (0.020 in.) Oversize Piston Cylinder Bore Standard ID	60.5 mm (2.38 in.)
0.50 mm (0.020 in.) Oversize Piston Cylinder Bore ID Wear Limit	60.665 mm (2.3887 in.)

ENGINE TOOLS AND MATERIALS

Tools and Materials

Special or Essential Tools

NOTE: Order tools according to information given in the U.S. SERVICEGARD™ Catalog or in the European Microfiche Tool Catalog (MTC).

Special or Required Tools

Tool Name	Tool No.	Tool Use
Digital Pulse Tachometer	JT07270	Used to check/adjust engine slow and fast idle rpm.
Compression Gauge	JDM-59	Used to check engine compression.
Spark Tester	D-05351ST	Used to check overall condition of ignition system.
5.5 mm Valve Guide Driver Tool	JDG504	Used to remove and install valve guides.
5.5 mm Valve Guide Reamer	JDG1023	Used to ream valve guides.
PLASTIGAGE®	NA	Used to check connecting rod-to-crankshaft clearance.

Other Materials

Other Material

Part No.	Part Name	Part Use
M79292	MPG-2 Polymer Multipurpose Grease	Prevents parts from seizing. Apply to engine crankshaft.
NA	SCOTCH-BRITE™, Abrasive Sheet/Pad	Clean cylinder head.
NA	Stanisol (or Kerosene)	Finish ream valve guides.
NA	Prussian Blue Compound	Check valve seat contact.
NA	Lapping Compound	Lap valves into valve seats.
NA	Lithium-Based Grease	Pack oil seals.
NA	Zinc Oxide/Wood Alcohol	Check block for cracks.

Service Parts Kits

The following kits are available through your parts catalog:

- Carburetor Assembly
- Carburetor Float Valve Kit
- Carburetor Float Kit
- Carburetor Drain Screw Kit
- Carburetor Float Chamber Screw Kit
- Carburetor Float Chamber Kit
- Carburetor Pilot Screw and Limiter Cap Kit
- Carburetor Pilot Jet Kit
- Carburetor Gasket Kit
- Engine Gasket Kit
- Piston Ring Kit (Standard)
- Piston Ring Kit (0.25 mm [0.010 in. oversize])
- Piston Ring Kit (0.50 mm [0.020 in. oversize])
- Piston (0.25 mm [0.010 in. oversize])
- Piston (0.50 mm [0.020 in. oversize])
- Connecting Rod (Standard)
- Connecting Rod (0.25 mm [0.010 in.] undersize)
- Governor Kit
- Cylinder Block

ENGINE COMPONENT LOCATION AND OPERATION

Product: John Deere 180B, 220B, 260B Walk-Behind Greensmower Service Repair Technical Manual

Full Download: <https://www.bobmanualstore.com/downloads/john-deere-180b-220b-260b-walk-behind-greensmower-service-repair-technical-manual/>

Component Location and Operation

External Engine Components

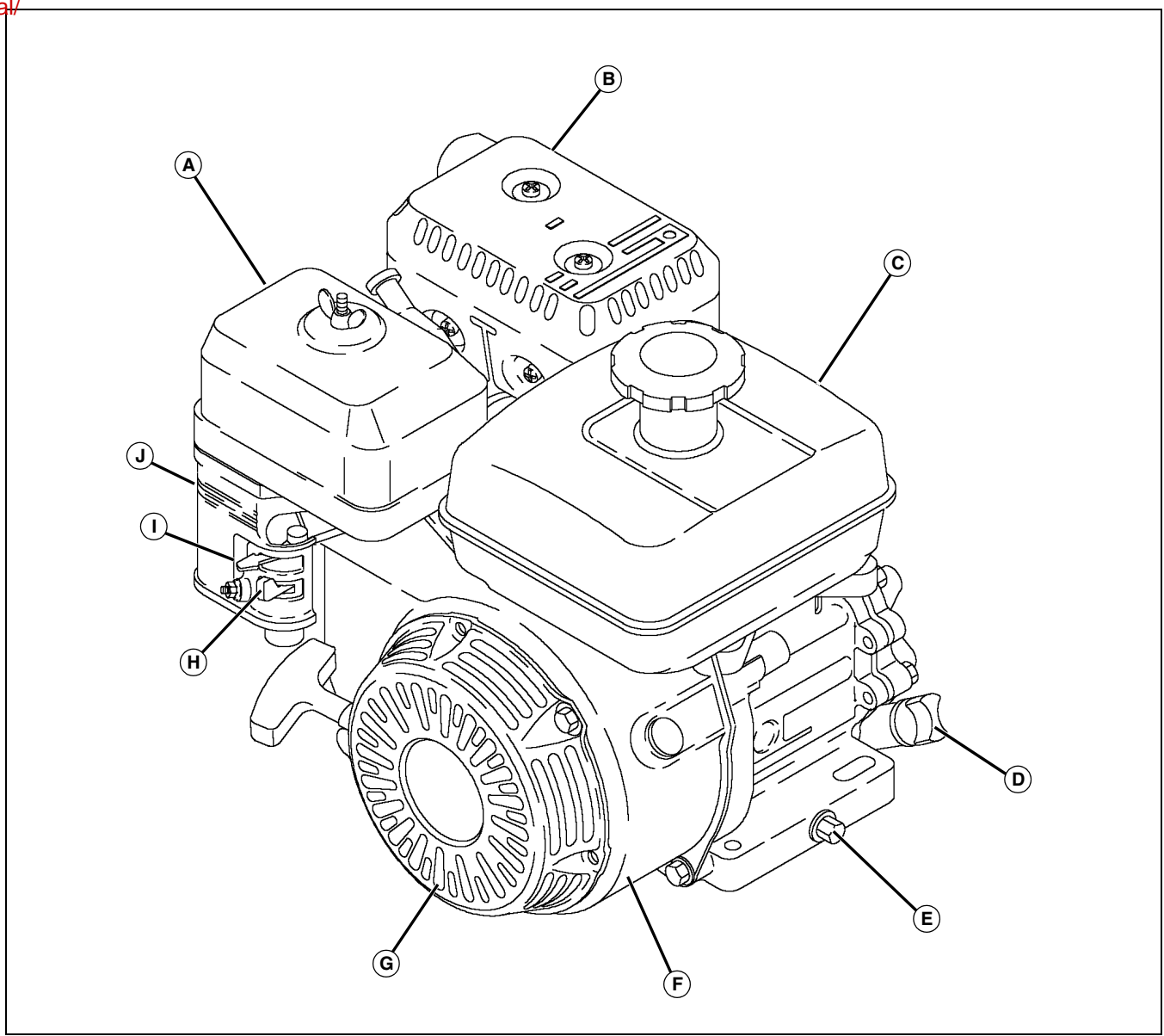

MX6040

- A - Air Cleaner**
- B - Muffler**
- C - Fuel Tank**
- D - Oil Dipstick**
- E - Oil Drain Plug**
- F - Blower Housing**
- G - Recoil Starter**
- H - Fuel Shutoff Lever**
- I - Choke Lever**
- J - Carburetor**

Sample manual. Download All 181 pages at:

<https://www.bobmanualstore.com/downloads/john-deere-180b-220b-260b-walk-behind-greensmower-service-repair-technical-manual/>