

2140 Tractor Technical Manual

CONTENTS

SECTION 10 – GENERAL

- Group 00 – Specifications and special tools
- Group 05 – Pre-delivery, delivery and after-sales inspections
- Group 10 – Lubrication and periodic service
- Group 15 – Engine and tractor tune-up
- Group 20 – Tractor separation (tractors without increased lift capacity)
- Group 25 – Tractor separation (tractors with increased lift capacity)

SECTION 20 – ENGINE

- Group 00 – Specifications
- Group 05 – Radiator

SECTION 30 – FUEL AND AIR INTAKE SYSTEM

- Group 00 – Specifications and special tools
- Group 05 – General information, diagnosing malfunctions
- Group 10 – Fuel tank and water trap
- Group 15 – Cold weather starting aids
- Group 20 – Speed control linkage
- Group 25 – Air cleaner

SECTION 40 – ELECTRICAL SYSTEM

- Group 00 – Specifications and special tools
- Group 05 – Description, diagnosing malfunctions and tests
- Group 10 – Wiring harnesses
- Group 15 – Controls and instruments
- Group 20 – Lighting systems
- Group 25 – Wiring diagrams
- Group 30 – Starting motor
- Group 35 – Alternator

SECTION 50 – POWER TRAIN

- Group 00 – Specifications and special tools
- Group 05 – Description, operation and lubricating system
- Group 10 – Clutch operating linkages
- Group 15 – Engine clutches
- Group 20 – Hi-Lo shift unit
- Group 25 – Creeper transmission
- Group 30 – Transmission shift linkage
- Group 35 – Synchronized transmission and transmission oil pump
- Group 40 – Collar shift transmission and transmission oil pump
- Group 45 – Differential
- Group 50 – Final drives
- Group 55 – Independent PTO
- Group 56 – Front PTO
- Group 60 – Mechanical front wheel drive

CONTENTS (Contd.)

SECTION 60 – STEERING SYSTEM AND BRAKES

- Group 00 – Specifications and special tools
- Group 05 – Hydrostatic steering (operating pressure: 12 000 kPa; 120 bar; 1740 psi)
- Group 06 – Hydrostatic steering (operating pressure: 15 000 kPa; 150 bar; 2180 psi)
- Group 10 – Power steering
- Group 15 – Manual steering
- Group 20 – Brakes

SECTION 70 – HYDRAULIC SYSTEM

- Group 00 – Specifications and special tools
- Group 05 – Description, diagnosing malfunctions and pressure tests
- Group 10 – Oil reservoir, filter, valves and oil cooler
- Group 15 – Hydraulic pumps
- Group 20 – Rockshaft
- Group 21 – Front hitch
- Group 25 – Selective control valves (spool type)
- Group 30 – Selective control valves (poppet valve type)
- Group 35 – Hose couplers
- Group 40 – Remote cylinder
- Group 45 – Selective control valves (Tractors manufactured in Spain)

SECTION 80 – MISCELLANEOUS

- Group 00 – Specifications and special tools
- Group 05 – Front axle
- Group 10 – Belt pulley
- Group 15 – Front and rear wheels
- Group 20 – Axle trailer hitch

SECTION 90 – OPERATOR'S CABS

- Group 00 – Specifications and special tools
- Group 05 – Air conditioning system
- Group 10 – Ventilation and heating
- Group 15 – Operator's seats
- Group 20 – OPU cab
- Group 25 – SG2 cab
- Group 30 – Roll guard

Section 10

General

CONTENTS OF THIS SECTION

GROUP 00 – SPECIFICATIONS AND SPECIAL TOOLS

	Page
Specifications	00-3
Serial numbers	00-3
Model numbers	00-3
Engine	00-3
Engine clutch	00-4
Cooling system	00-4
Fuel system	00-4
Electrical system	00-5
Synchronized transmission	00-5
Collar shift transmission	00-5
Hi-Lo shift unit	00-5
Creeper transmission	00-5
Differential and final drives	00-6
Differential lock	00-6
PTO	00-6
Mechanical front wheel drive	00-6
Hydrostatic steering	00-7
Power steering	00-7
Manual steering	00-7
Foot brakes	00-7
Handbrake	00-7
Hydraulic system	00-7
Capacities	00-7
Travel speeds	00-8
Front and rear wheels	00-8
Dimensions and weights	00-8
Predelivery, delivery and after-sales inspections	00-9
Lubrication and service	00-10
Tune-up	00-11
Tractor separation	00-12
Standard torques	00-14
Special tools	00-16

GROUP 05 – PREDELIVERY, DELIVERY AND AFTER-SALES INSPECTIONS

	Page
Tractor storage	05-1
Predelivery inspection	05-2
Delivery inspection	05-10
After-sales inspection	05-10

GROUP 10 – LUBRICATION AND SERVICE

Lubrication and service	10-1
-----------------------------------	------

GROUP 15 – TUNE-UP

Preliminary engine testing	15-1
Dynamometer test	15-1
Testing compression pressure	15-2
Tune-up	15-2
Checking tractor operation	15-7
Standard torques	15-8

GROUP 20 – TRACTOR SEPARATION (Tractors without Increased Lift Capacity)

Separating between engine and tractor front end	20-1
Removal and installation of engine	20-7
Removal and installation of clutch housing	20-11
Removal and installation of final drives	20-15
Removal and installation of rockshaft	20-21
Removal and installation of operator's cabs	20-24

GROUP 25 – TRACTOR SEPARATION (Tractors with Increased Lift Capacity)

	Page
Special tools	10-25-1
Torques for hardware	10-25-5
Capacities	10-25-7
Standard torques for hardware	10-25-7
Important notes	10-25-9
Removing tractor front end	10-25-10
Installing tractor front end	10-25-18
Separating between engine and clutch housing	10-25-20
Joining tractor between engine and clutch housing	10-25-28
Removing engine	10-25-31
Installing engine	10-25-32
Removing clutch housing	10-25-33
Installing clutch housing	10-25-34
Removing transmission	10-25-35
Installing transmission	10-25-41
Removing final drives	10-25-44
Installing final drives	10-25-52
Removing rockshaft	10-25-55
Installing rockshaft	10-25-56
Removing front wheel drive axle	10-25-58
Installing front wheel drive axle	10-25-60
Removing SG2 cab	10-25-63
Installing SG2 cab	10-25-73
Removing front hitch	10-25-76
Installing front hitch	10-25-79
Removing front PTO	10-25-81
Installing front PTO	10-25-83

Group 00

Specifications and Special Tools

Specifications

Serial Numbers

The engine serial number is stamped into the plate located on the lower front right-hand side of the cylinder block.

NOTE: When ordering engine parts, quote all digits of serial number stamped on the plate.

The plate showing the tractor serial number is located on the right-hand side of the front axle carrier.

NOTE: When ordering tractor spare parts (excluding engine parts), quote all digits and letters of serial number stamped on the plate.

A plate showing the tractor type, transmission serial number, cone point measurement etched into pinion face of differential drive shaft as well as reduction of differential is located on the right-hand side of the transmission case.

Model Numbers

The fuel injection pump, fuel injection nozzles, alternator, starting motor, hydrostatic steering valve, compressor of air conditioning system (when equipped) and hydraulic pump have model numbers to facilitate identification of different makes of a given unit.

Engine

Number of cylinders		4
Cylinder liner bore	106.5 mm	4.19 in.
Stroke	110 mm	4.33 in.
Displacement	3920 cm ³	239 cu.in.
Compression ratio		16.8 : 1
Maximum torque at 1600 rpm	270 Nm	199 ft-lb
Firing order		1 - 3 - 4 - 2
Valve clearance (engine hot or cold)		
Intake valve035 mm	0.014 in.
Exhaust valve045 mm	0.018 in.

Fast idle speed	2610 to 2660 rpm
Slow idle speed	700 to 800 rpm
Rated engine speed	2500 rpm
Working speed range	1600 to 2500 rpm
Flywheel horsepower at engine rated speed — 2500 rpm	
According to DIN 7002060 kW 82 hp
PTO* horsepower at engine rated speed — 2500 rpm	
According to DIN 7002054 kW 74 hp
According to SAE J816b54 kW 72 hp
Lubrication system	Full internal force feed system with full flow filter

Engine Clutch Single dry disk clutch with torsion damper, foot-operated

Cooling System

Type	Pressurized system with centrifugal pump
Temperature regulation	Thermostat

Fuel System

Type	Direct injection
Fuel injection pump timing to engine	TDC
Fuel injection pump type	Distributor type
up to engine serial no. 526 865 CD	Roto Diesel No. R 3443 F 680
from engine serial no. 526 866 CD	Roto Diesel No. R 3443 F 910
Air cleaner	Dry-type air cleaner with secondary (safety) element

* With the engine run in (above 100 hours of operation) and having reached operating temperature (engine and transmission); measured by means of a dynamometer. Permissible variation $\pm 5\%$.

Electrical System

- Batteries 2 x 12 volts, 55 Ah
- Tractors with SG2 cab 2 x 12 volts, 55 Ah or 66 Ah
- Alternator with internal regulator
- Tractors without operator's cab 14 volts, 33 or 55 amps.
- Tractors with operator's cab 14 volts, 55 amps.
- Starting motor. 12 volts, 3 kW (4 hp)
- Battery terminal grounded negative

Synchronized Transmission

- Type Synchronized transmission
- Gear selections 8 forward and 4 reverse
- Gear shifting Two forward groups and one reverse group
Synchronized forward and reverse shifting
within groups

Collar Shift Transmission

- Type Helical gears
- Gear selections 8 forward, 4 reverse speeds
- Gear shifting Two forward ranges, One reverse range

Hi-Lo Shift Unit

- Type Hydraulic gear reduction unit which can be
shifted under load with "wet" multiple
disk clutch and brake packs
- Travel speed decreases in each gear by Approx. 20 %
- Shifting to reduced (Lo) speed Preloaded cup springs
- Shifting to normal (Hi) speed Hydraulic

Creeper Transmission

- Type Synchronized reduction unit
- Travel speed decreases in low (l) and reverse ranges by approx. 79 %
- Shifting both ranges Mechanical and not under load

Differential and Final Drives

Type of differential Spiral bevel gears
 Type of final drive Planetary reduction drive

Differential Lock

Operation Hand or foot operated
 Disengage Will disengage automatically as soon as traction has equalized

PTO

Type Independent of transmission, can be engaged and disengaged under load

PTO speeds with engine speed of:

2400 rpm* or 2040 rpm** 540 rpm
 2400 rpm 1000 rpm
 (changing PTO stub shaft or handshift change)

PTO clutch Hydraulically operated "wet" disk clutch
 PTO brake Hydraulically operated "wet" disk brake

PTO SPEEDS (in rpm)

Engine speed	540 rpm shaft	1000 rpm shaft
800	180* or 210**	335
2400* or 2040**	540	1000
2500	565* or 660**	1040
2660	600* or 705**	1110

Mechanical Front Wheel Drive

Type Engaged hydraulically, under full load with "wet" disk clutch
 Control Electrical/hydraulic solenoid switch
 Engagement Preloaded cup springs
 Disengagement Hydraulic

* up to tractor serial no. 507 867 L
 ** From tractor serial no. 507 868 L

Hydrostatic SteeringWithout mechanical linkage between steering valve and the front wheels

Power SteeringHydraulically operated steering linkage

Manual SteeringRecirculating ball bearing type

Foot BrakesSelf-adjusting, hydraulically operated "wet" disk brakes

HandbrakeMechanically operated band-type locking brake acting on the differential

Hydraulic System

TypeClosed center, constant pressure system

Standby pressure*19000 kPa 190 bar 2760 psi

Operating pressure**17000 kPa 170 bar 2470 psi

Hydraulic pump4 or 8-piston pump with variable displacement

Capacities

Fuel tank

Plastic tank 102 liters 26.9 U.S.gals.
 Metal tank 90 liters 23.8 U.S.gals.

Cooling system

Without operator's cab 13 liters 3.4 U.S.gals.
 With operator's cab 15 liters 4 U.S.gals.

Engine crankcase

Without filter change 8 liters 2.1 U.S.gals.
 With filter change8.5 liters 2.25 U.S.gals.

Transmission - Hydraulic system (including oil reservoir and oil cooler)

Synchronized transmission

Initial filling 64 liters 16.9 U.S.gals.
 Oil change 56 liters 14.8 U.S.gals.

Collar shift transmission

Initial filling 52 liters 13.75 U.S.gals.
 Oil change 44 liters 11.6 U.S.gals.

Oil reservoir 4 liters 1.1 U.S.gals.

Oil cooler 2 liters 0.5 U.S.gals.

On tractors for Canada only:

* 15500 kPa 155 bar 2250 psi
 ** 14000 kPa 140 bar 2050 psi

Capacities (Contd.)

Mechanical front wheel drive

Front axle housing		
up to serial no. 449 999 L	6.5 liters	1.7 U.S.gals.
from serial no. 450 000 L	7.0 liters	1.85 U.S.gals.
Wheel hub housing, each		
up to serial no. 449 999 L	1.0 liter	0.3 U.S.gals.
from serial no. 450 000 L	0.75 liter	0.2 U.S.gals.

Belt pulley 1.0 liter 0.3 U.S.gals.

Travel Speeds see Operator's Manual

Front and Rear Wheels

Tires, tread widths, tire pressures and ballast weights see Operator's Manual

Dimensions and Weights see Operator's Manual

Predelivery, Delivery and After-Sales Inspections

ENGINE SPEEDS

Slow idle	700 to 800 rpm
Fast idle	2610 to 2660 rpm
Rated speed	2500 rpm

FAN BELT

The fan belt should have 19 mm (3/4 in.) flex with 90 N (20 lb) pull midway between crankshaft and alternator or water pump (use a spring scale).

COMPRESSOR BELT

The compressor belt should have 19 mm (3/4 in.) flex with 60 N (13 lb) pull midway between pulleys.

BATTERIES

Specific gravity at an electrolyte temperature of 20°C (68°F)

Normal and arctic conditions	1.28
Tropical conditions	1.23

CLUTCH OPERATING ASSY.

Tractors without Cab or with OPU

Clutch pedal free travel	approx. 25 mm 1 in.
------------------------------------	------------------------

Tractors with SG2 Cab

Slave cylinder operating rod, stroke	8.5 to 12.0 mm 5/16 to 15/32 in.
------------------------------------------------	-------------------------------------

FRONT WHEEL TOE-IN

Tractors without front wheel drive	3 to 6 mm	0.12 to 0.25 in.
Tractors with MFWD	0 to 3 mm	0 to 0.12 in.

TORQUES FOR HARDWARE

Front wheel rim to hub		
Tractors without front wheel drive	180 Nm	130 ft-lb
Tractors with MFWD	300 Nm	220 ft-lb
Axle knees to axle center, cap screws	400 Nm	300 ft-lb

Tractors with Hydrostatic Steering

Tie rod clamps		
Cap screw M 10	55 Nm	40 ft-lb
Cap screw M 12	90 Nm	65 ft-lb
Tie rod tube, cap screw	55 Nm	40 ft-lb

Tractors with Power Steering or Manual Steering

Outer clamp of tied rod, cap screw	90 Nm	65 ft-lb
Inner clamp of tie rod, cap screw	55 Nm	40 ft-lb

TORQUES FOR HARDWARE (Contd.)

Rear wheels		
Rear wheels to axle	400 Nm	300 ft-lb
Wheel disk to hub (rack-and-pinion axle)	400 Nm	300 ft-lb
4-post roll guard		
Roll guard to fender, cap screws	120 Nm	85 ft-lb
U-bolt hex. nuts	130 Nm	95 ft-lb
2-post roll guard		
To final drive housings, cap screws	230 Nm	170 ft-lb
Both supports to crossbar, cap screws	230 Nm	170 ft-lb
Rear wheel fenders to final drive housings, hex. nuts	130 Nm	95 ft-lb
SG2 cab rubber mounting blocks, hex. nuts	200 Nm	145 ft-lb

Lubrication and Service**CAPACITIES**

Engine crankcase		
without filter change	8 liters	2.1 U.S.gals.
with filter change	8.5 liters	2.25 U.S.gals.
Hydraulic clutch operating system	300 cm ³	10.5 fl.oz.

Cooling System

without operator's cab	13 liters	3.4 U.S.gals.
with operator's cab	15 liters	4.0 U.S.gals.

Transmission - Hydraulic system (including oil reservoir and oil cooler)**Synchronized transmission**

Initial filling	64 liters	16.8 U.S.gals.
Oil change	56 liters	14.8 U.S.gals.

Collar shift transmission

Initial filling	52 liters	13.75 U.S.gals.
Oil change	44 liters	11.6 U.S.gals.

Mechanical front wheel drive

Front axle housing		
up to serial no. 449 999 L	6.5 liters	1.7 U.S.gals.
from serial no. 450 000 L	7.0 liters	1.85 U.S.gals.

Wheel hub housing, each		
up to serial no. 449 999 L	1.0 liter	0.3 U.S.gals.
from serial no. 450 000 L	0.75 liter	0.2 U.S.gals.

Belt pulley	1 liter	0.3 U.S.gals.
-----------------------	---------	---------------

SERVICE INTERVALS

Checking crankcase oil level	every 10 hours
Changing engine oil	every 200 hours
Changing engine oil filter	every 200 hours
Checking fuel filter	every 10 hours
Changing fuel filter	every 1000 hours
Checking transmission/hydraulic system oil level	every 50 hours
Changing transmission/hydraulic system oil filter	every 500 hours
Changing transmission/hydraulic oil	every 1000 hours
Changing hydrostatic steering filter	every 1000 hours
Cleaning hydraulic pump strainer	every 1000 hours
Checking MFWD oil level	every 100 hours
MFWD oil change	every 1000 hours
Cleaning and packing front wheel bearings	every 1000 hours
Lubricating grease fittings	
Mechanical front wheel drive universal-jointed shaft	every 50 hours
in wet and muddy conditions	every 10 hours
Front axle and front axle bearings	every 50 hours
in wet and muddy conditions	every 10 hours
Clutch throw-out bearing grease fitting (when equipped)	every 100 hours
Rear axle bearings	every 500 hours
in wet and muddy conditions	every 10 hours
Three-point hitch	every 200 hours
Front hitch	every 200 hours
Front PTO drive shaft	every 200 hours

Tune-Up

PTO horsepower* at 2500 rpm rated engine speed

According to DIN 70020.54 kW		74 hp
According to SAE J 816b54 kW		72 hp
Slow idle			700 to 800 rpm
Fast idle			2610 to 2660 rpm
Rated engine speed			2500 rpm
Air intake system vacuum	3.5 to 6.0 kPa	35 to 60 mbar	14 to 25 in. water head
Air cleaner restriction warning switch closes at a vacuum of	5.5 to 6.5 kPa	55 to 65 mbar	22 to 26 in. water head
Radiator cap high pressure valve opens at.	40 to 50 kPa	0.4 to 0.5 bar	6 to 7 psi
Radiator cap low pressure valve opens at.	0 to 4 kPa	0 to 0.04 bar	0 to 0.6 psi

FAN BELT

Fan belt should have 19 mm (3/4 in.) flex with 90 N (20 lb) pull midway between crankshaft and alternator or water pump (use a spring scale).

COMPRESSOR BELT

Compressor belt should have 19 mm (3/4 in.) flex with 60 N (13 lb) pull midway between pulleys.

* With the engine run in (more than 100 hours of operation) and having reached operating temperature (engine and transmission); measured by means of a dynamometer. Permissible variation $\pm 5\%$.

Tractor Separation

TORQUES FOR HARDWARE (TRACTORS WITHOUT INCREASED LIFTING CAPACITY)

Front axle carrier to engine block		
front attaching cap screws (4 used)	230 Nm	170 ft-lb
rear attaching cap screws (2 used)	180 Nm	130 ft-lb
Front axle carrier to oil pan, cap screws	400 Nm	300 ft-lb
Hydraulic pump drive shaft, cap screws.	50 Nm	35 ft-lb
Jointed shaft flange to front axle		
drive hub (tractors with MFWD), cap screws	75 Nm	55 ft-lb
Drag link* to bell crank or steering arm, slotted nut**	75 Nm	55 ft-lb
Clutch housing to engine block		
cap screws	230 Nm	170 ft-lb
hex. nuts	230 Nm	170 ft-lb
Oil pan to clutch housing, cap screws	230 Nm	170 ft-lb
Clutch housing to transmission, cap screws	160 Nm	120 ft-lb
Transmission case drain plugs	135 Nm	100 ft-lb
Retainer of hydraulic lines to clutch housing, cap screw	45 Nm	32 ft-lb
Final drive housings to transmission case, cap screws	120 Nm	85 ft-lb
Rockshaft housing to transmission case, cap screws	120 Nm	85 ft-lb
Rear wheels to rear axle	400 Nm	300 ft-lb
Wheel disk to hub (on tractors equipped with rack-and-pinion axle)	400 Nm	300 ft-lb
4-post roll guard		
Roll guard to fender, cap screws	120 Nm	85 ft-lb
U-bolt hex. nuts	130 Nm	95 ft-lb
2-post roll guard		
To final drive housings, cap screws	230 Nm	170 ft-lb
Both supports to crossbar, cap screws	230 Nm	170 ft-lb

* On tractors with power or manual steering

** *NOTE: If cotter pin cannot be inserted when tightening to the specified torque, turn nut to next slot and secure with cotter pin.*

10-00-14 Specifications and Special Tools

General

Basic weight to front axle carrier, cap screws	400 Nm	300 ft-lb
Drawbar to transmission case, cap screws	120 Nm	85 ft-lb

OPU Cab





Cab to rubber bearing block, slotted nuts*	10 to 20 Nm	7 to 14 ft-lb
Rubber bearing block to bearing and pivot brackets, cap screws	50 Nm	35 ft-lb
Bearing pivot bracket to final drive housing, cap screws	100 Nm	70 ft-lb
Bearing bracket to battery box, cap screws	50 Nm	35 ft-lb
Battery box to flywheel housing, upper cap screw	200 Nm	145 ft-lb
lower cap screws	100 Nm	70 ft-lb

SG2 Cab

Cab to rubber bearing blocks, cap screws and hex. nuts	200 Nm	145 ft-lb
---------------------------------------------------------------------	--------	-----------

* *NOTE: Insert cotter pin within specified torque.*

Standard Torques

Recommended torques in Nm, mkp and ft-lb for UNC and UNF cap screws						
Head marking (Identifying strength)	  or 10.9*			  or 12.9**		
	Thread-O.D. (In.)	Nm	mkp	ft-lb	Nm	mkp
1/4	15	1.5	10	20	2	15
5/16	30	3	20	40	4	30
3/8	50	5	35	70	7	50
7/16	80	8	55	110	11	80
1/2	120	12	85	170	17	120
9/16	180	18	130	240	24	175
5/8	230	23	170	320	32	240
3/4	400	40	300	580	58	425
7/8	600	60	445	930	93	685
1	910	91	670	1400	140	1030
1-1/8	1240	124	910	1980	198	1460
1-1/4	1700	170	1250	2800	280	2060

NOTE: A variation of $\pm 10\%$ is permissible for all torques indicated in this chart.

Torque figures indicated above and in the Specification sections of this manual are valid for non-greased or non-oiled threads and heads unless otherwise specified. Therefore, do not grease or oil bolts or cap screws unless otherwise specified in this manual.

* Tempered steel high strength bolts and cap screws

** Tempered steel extra high strength bolts and cap screws

Recommended torques in Nm, mkp and ft-lb for metric cap screws									
Head marking (Identifying strength)	8.8*			10.9**			12.9***		
Thread-O.D. (mm)	Nm	mkp	ft-lb	Nm	mkp	ft-lb	Nm	mkp	ft-lb
M5	7	0.7	5	9	0.9	6.5	10	1	8.5
M6	10	1	8.5	15	1	10	20	2	15
M8	30	3	20	40	4	30	40	4	30
M10	50	5	35	80	8	60	90	9	70
M12	100	10	75	140	14	100	160	16	120
M14	160	16	120	210	21	155	260	26	190
M16	240	24	175	350	35	260	400	40	300
M20	480	48	355	650	65	480	780	78	575
M24	820	82	605	1150	115	850	1350	135	995
M30	1640	164	1210	2250	225	1660	2700	270	1990
M36	2850	285	2110	4000	400	2950	4700	470	3465

NOTE: A variation of $\pm 10\%$ is permissible for all torques indicated in this chart.

Torque figures indicated above and in the Specification sections of this manual are valid for non-greased- or non-oiled threads and heads unless otherwise specified. Therefore, do not grease or oil bolts or cap screws unless otherwise specified in this manual.

- * Regular bolts and cap screws
- ** Tempered steel high strength bolts and cap screws
- *** Tempered steel extra high strength bolts and cap screws

Recommended torques in Nm, mkp and ft-lb for pipe and hose connections						
Thread size	with O-rings			with cone		
	Nm	mkp	ft-lb	Nm	mkp	ft-lb
3/8-24 UNF	7.5	0.75	5.5	8	0.8	6
7/16-20 UNF	10	1	7	12	1.2	9
1/2-20 UNF	12	1.2	9	15	1.5	11
9/16-18 UNF	15	1.5	11	25	2.5	18
3/4-16 UNF	25	2.5	20	45	4.5	35
7/8-14 UNF	40	4	30	60	6	45
1-1/16-12 UNC	60	6	45	100	10	75
1-3/16-12 UNC	70	7	50	120	12	90
1-5/16-12 UNC	80	8	60	140	14	105
1-5/8-12 UNC	110	11	80	190	19	140
1-7/8-12 UNC	150	15	110	220	22	160

Special Tools

Tune-Up

Tools	Description and Part No.	Use
 <p>L30515A</p>	FKM 10002	Measuring air intake system vacuum

Fig. 1 — Pressure Gauge Set

 <p>L106472</p>	Vacuum gauge and connector FKM 10310	Measuring air intake system vacuum
Consisting of:		
1 Vacuum gauge FKM 10242		
2 T-piece FKM 10308		
3 Connector FKM 10309		

Fig. 2 — Vacuum Gauge and Connectors

Tool

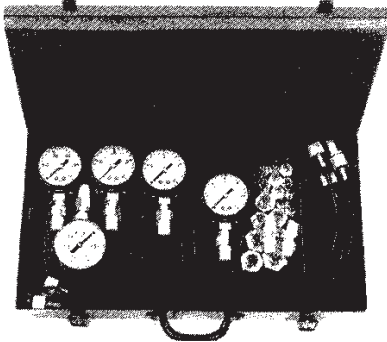
Description
and
Part No.

Use

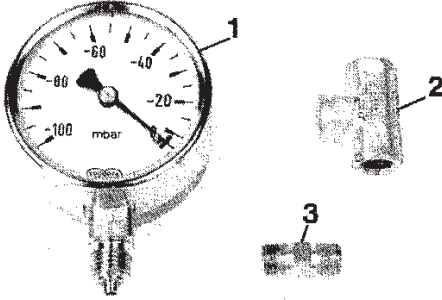
Tractor Separation

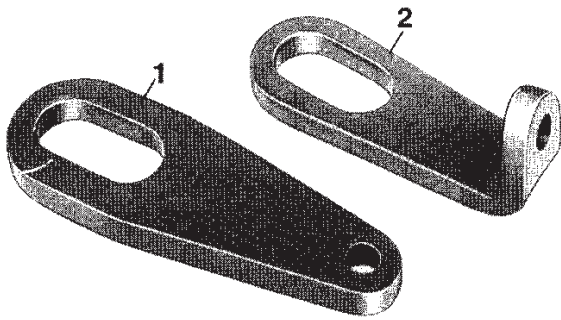

- 1 Lifting eye,
straight
JD-244-1
- 2 Lifting eye,
bent
JD-244-2

Tractor separation

L23985

Fig. 3 – Lifting Eyes, Straight and Bent

Tool

Description and Part No.

Use

KJD 10129

Separating between engine and clutch housing on tractors with SG2 cab

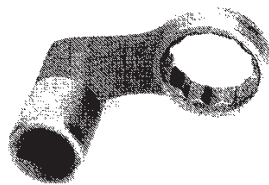

L107 001

Fig. 4 – Special Spanner

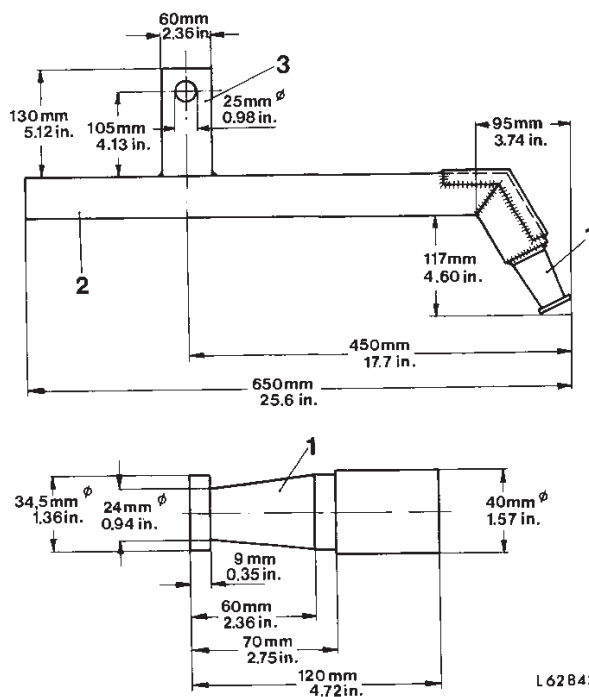

L 62843

Removing rockshaft (tractors with OPU)

Fig. 5 – Tool for Removing Rockshaft (Self-Manufacture)

- 1 Round material 40 x 120 mm (1.57 x 4.72 in.)
- 2 Pipe 48 x 3.5 x 650 mm (1.89 x 0.14 x 25.6 in.)
- 3 Flat metal 60 x 12 x 130 mm (2.36 x 0.47 x 5.12 in.)

Tractor Separation (Contd.)

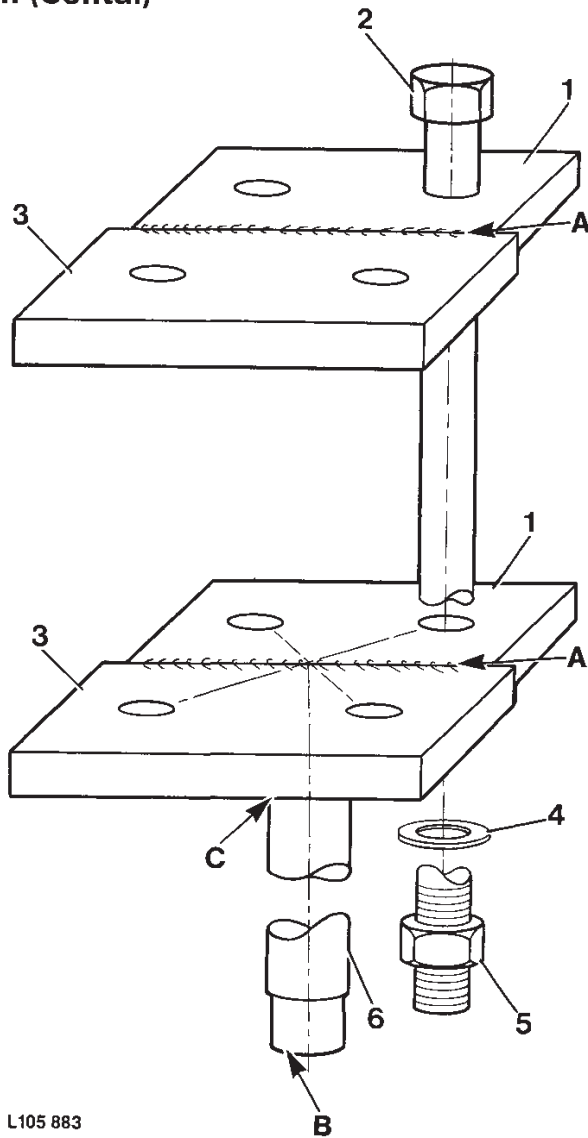

L105 883

Fig. 6 – Holding Device (Self-Manufacture), Removal of Final Drive Assemblies

- | | | | |
|---|-------------------------------------------|---|--------------------------------------------------|
| A | Weld both retaining plates together | B | Adapter lug diameter to fit bore of trolley jack |
| C | Weld round steel in center of both plates | 4 | Washer 14 H 1698 (2 used) |
| 1 | Retaining plate T 25671 (2 used) | 5 | Hex. nut 14 H 1039 (2 used) |
| 2 | Cap screw L 29785 (2 used) | 6 | Round steel 50 x 250 mm (1.97 x 9.84 in.) |
| 3 | Retaining plate T 32429 (2 used) | | |

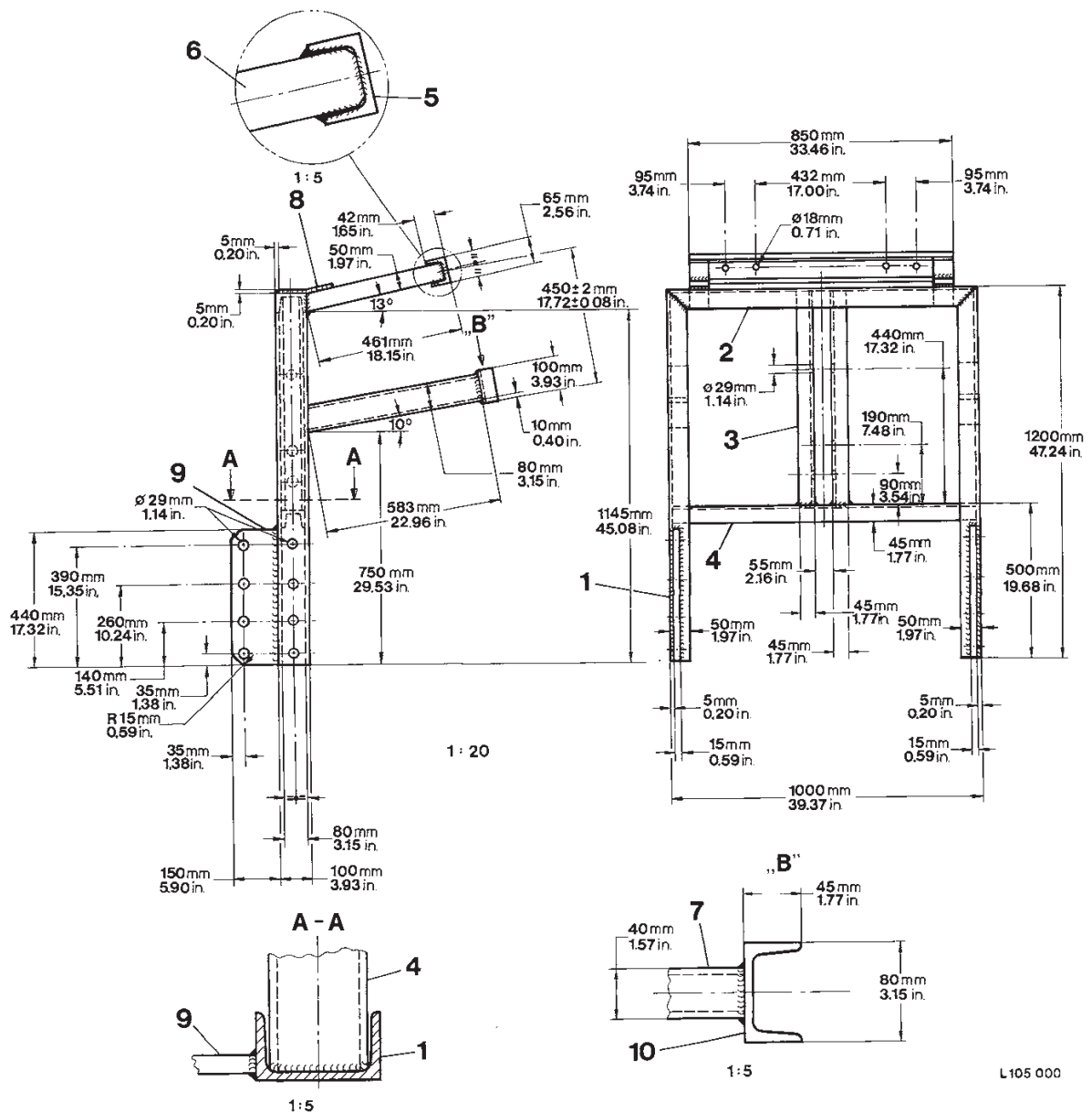
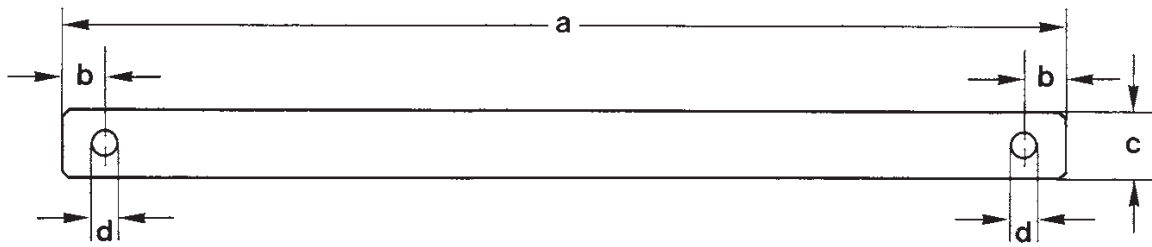

Fig. 7 – Lifting Device (Self-Manufacture), Removal of SG2 Cab (Quality Grade ST 37)

- 1 U-profile steel 100 x 1200 mm (3.94 x 47.24 in.) (2 used)
- 2 U-profile steel 100 x 1000 mm (3.94 x 39.37 in.) (1 used)
- 3 U-profile steel 80 x 694 mm (3.15 x 27.32 in.) (1 used)
- 4 U-profile steel 80 x 988 mm (3.15 x 38.9 in.) (1 used)
- 5 U-profile steel 65 x 850 mm (2.56 x 33.46 in.) (1 used)
- 6 Square steel 50 x 50 x 461 mm (1.97 x 1.97 x 18.15 in.) (2 used)
- 7 Square tubular steel 80 x 40 x 5 x 583 mm (3.15 x 1.58 x 0.2 x 22.95 in.) (2 used)
- 8 Flat steel 50 x 5 x 190 mm (1.97 x 0.2 x 7.48 in.) (2 used)
- 9 Flat steel 150 x 15 x 440 mm (5.9 x 0.59 x 17.32 in.) (2 used)
- 10 U-profile steel 80 x 100 mm (3.15 x 3.94 in.) (2 used)

Tractor Separation (Contd.)

L105 887

Fig. 8 – Steel Shaft (Self-Manufacture) for SG2 Cab Lifting Device

a 1100 mm (43.31 in.)
b 25 mm (0.98 in.)

c Diameter 22 mm (0.87 in.) with Cat. I draft links
29 mm (1.14 in.) with Cat. II draft links
d Diameter 5 mm (0.2 in.)

Group 05**Predelivery, Delivery and After-Sales Inspections**

The John Deere Delivery Receipt, when properly filled out and signed by the dealer and customer, verifies that the predelivery and delivery services were satisfactorily performed. When delivering this machine, give the customer his copy of the delivery receipt and the operator's manual. Explain their purpose to him.

To promote complete customer satisfaction, a predelivery inspection including mending of possible shipping damage and giving the finishing touches to the tractor, is of prime importance to the dealer.

After the first 100 operating hours an inspection should be performed by the dealer to make sure that the tractor is in proper operating condition.

The predelivery and after-sale inspection check lists in the operator's manual will be completed by the dealer when the inspections are being performed. He will then forward them to the sales branch service department.

Tractor Storage

When storing a new tractor, proceed as follows:

Short-Term (Under 30 Days)

1. Fill fuel tank. This prevents condensation of moisture in tank.
2. Check engine oil level, transmission-hydraulic oil level, and coolant level. Add oil or coolant if necessary. During cold weather, be sure coolant contains sufficient anti-freeze.
3. Check electrolyte level in batteries. If electrolyte does not cover plates, add distilled water. Make sure batteries are fully charged.
4. Store tractor in a dry, protected place. If necessary to store tractor outside, cover it with a protective material. Protect tires from heat, sunlight, and petroleum products.

Long Term (Over 30 Days)

To protect engine, fuel system, transmission and hydraulic system, use the AR 41785 rust inhibitor. The above part no. includes one can of rust inhibitor, masking tape and protective caps to cover all engine openings.

Protect as follows:

1. Add 255 cm³ (9 oz.) of rust inhibitor to the engine oil.
2. Add 205 cm³ (7 oz.) of rust inhibitor to the oil in the transmission/hydraulic system on tractors with collar shift transmission and 250 cm³ (8.5 oz.) on tractors with synchronized transmission.
3. Drain fuel tank, pour 170 cm³ (6 oz.) of rust inhibitor into the empty tank and add approx. 10 liters (2.6 U.S. gals.) of fuel. Start engine and operate it at fast idle for 15 to 20 minutes to distribute the mixture through the whole fuel system. While the engine is running, operate the complete hydraulic system several times. Shut off engine in time to leave some fuel in the tank. Then allow the engine to cool down for 15 to 20 minutes.
4. Prepare 15 cm³ (0.5 oz.) of rust inhibitor for each cylinder. Remove plug of intake manifold or connecting pipe of starting fluid adapter at

the intake manifold, whichever applies, inject rust inhibitor into the intake manifold. Pull out shut-off knob and crank engine with starter several times.

However, do not allow the engine to start. Otherwise the whole procedure must be repeated.

After the rust inhibitor has been added, the engine may not be started again.

IMPORTANT! Rust inhibitor agents evaporate very easily. For this reason, seal all openings after the inhibitor has been added. Also, always keep the inhibitor container closed.

5. Fill the fuel tank.
6. Remove batteries. Add distilled water, if necessary. Charge the batteries and store in a cool, dry place where they will not freeze.
7. Seal all openings such as the vent tube and exhaust outlet.
8. Slacken fan belt and air conditioning compressor belt (if equipped).
9. Replace or repair damaged parts. Touch up any painted surfaces which are scratched or chipped.
10. Coat exposed metal surfaces, such as axles and piston rods of hydraulic cylinders, with grease or corrosion preventative.
11. Store the tractor in a dry, protected place. If the tractor is stored outside, cover it with a waterproof tarpaulin.
12. Block up the tractor so that tires do not touch the ground. Protect tires from heat and sunlight.

Removing the Tractor from Storage

1. Remove all protective coverings.
2. Check crankcase and transmission/hydraulic system oil levels.

3. Check coolant level.
4. Check tire inflation pressure.
5. Install batteries and connect cable and ground strap.
6. Adjust fan belt and compressor belt (if equipped) tension.
7. Carry out 500-hour check.
8. Run engine at approx. 1500 rpm for some minutes. Check all systems before placing tractor under load.

IMPORTANT! With engine shut-off knob pulled out, turn over engine by means of starting motor until engine oil pressure has built up (engine oil pressure indicator light goes out). Then push in engine shut-off knob and run engine at approximately 1900 rpm.

Predelivery Inspection

Before delivering the tractor to the customer, the following checks and services should be performed by the dealer:

Engine

LEAKS

Check engine and fuel lines for leaks. Repair as necessary.

CHECKING CRANKCASE OIL LEVEL

NOTE: Tractor should be on a level surface when oil level is checked. If it is not, check only to make sure the crankcase is not dry. Recheck oil level later, when tractor is on level ground.

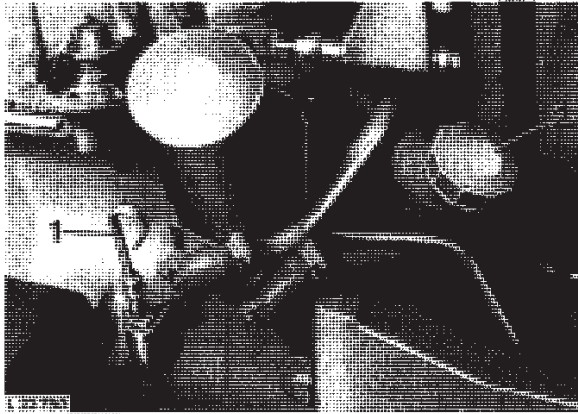

Fig. 1 – Engine Oil Dipstick and Filler Cap

- 1 Dipstick
- 2 Filler cap

1. Pull out dipstick 1 (fig. 1) and check oil level.
2. If necessary, add oil to bring oil level to top mark on dipstick. Use John Deere Torq-Gard Supreme engine oil SAE 10W-20 or an equivalent oil (see group 10).

CHECKING COOLANT LEVEL



Fig. 2 – Radiator Filler Cap

1. Remove radiator filler cap and check coolant level. Coolant level must be midway between the filler neck and top of radiator core.

2. If necessary, add coolant to obtain this level.

John Deere Engine Cooling Fluid is filled into the cooling system at the factory. It protects the engine against corrosion and against frost down to -36°C (-35°F).

IMPORTANT: Use only John Deere Engine Cooling Fluid in the cooling system, independent of the season.

If no John Deere Engine Cooling Fluid is available use a mixture of 50 % ethylene-glycol antifreeze/ anticorrosion inhibitor and 50 % clear, soft water. This mixture guarantees engine protection against corrosion and against frost down to -36°C (-35°F).

Never use any cooling system sealing additives.

IDLE SPEEDS

1. Check slow and fast idle speeds and adjust, if necessary.
2. Slow idle speed: 700 to 800
3. Fast idle speed: 2610 to 2660
4. Warm up engine to operating temperature and check speeds. Adjust if necessary (see Section 30, Group 20).

ENGINE SHUT-OFF CABLE

1. Check operation of shut-off cable. Move hand throttle lever completely forward and idle engine for 1 to 2 minutes.
2. Completely pull out shut-off knob, making sure engine stops immediately.
3. If necessary, adjust shut-off cable (see Section 30, Group 20).

AIR CLEANER AND SAFETY ELEMENT

Fig. 3 — Air Cleaner and Safety Element

- 1 Air cleaner element
- 2 Dust unloading valve
- 3 Safety element

1. Check air cleaner and safety elements for proper installation.
2. Make sure that dust unloading valve 2 (fig. 3) (rubber cap) is installed on air cleaner.

AIR INTAKE CONNECTIONS

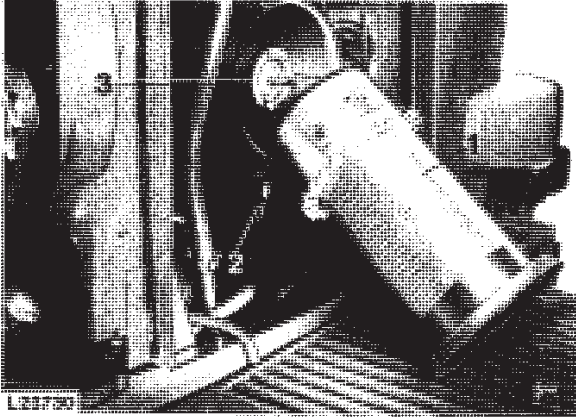
Check air intake connections for tightness. Tighten any loose clamps.

EXHAUST STACK

1. Install exhaust stack, making sure it is in vertical position.
2. Install exhaust stack flap with flap hinge at the rear (as seen in direction of forward travel). When closed, flap should not contact exhaust stack end. If necessary, clamp flap to exhaust stack to obtain a clearance of 2 mm (1/16 in.) between flap and stack end.

CHECKING V-BELT TENSION**Fan Belt**

The fan belt should have 19 mm (3/4 in.) flex with 90 N (20 lb) pull midway between crankshaft and alternator or water pump (use a spring scale).

Compressor Belt (if equipped)

Compressor belt should deflect 19 mm (3/4 in.) when a 60 N (13 lb) force is applied midway between pulleys.

Electrical System**BATTERIES**

1. Check battery terminals and battery cable ends. If they are corroded, clean and coat them with petroleum jelly.
2. Check electrolyte level in each battery cell. Add distilled water if necessary to bring level above cell plates.
3. If batteries are not fully charged, charge them. Remove cell caps before charging the battery.

Important Notes

1. If the engine is to be run for a short time without battery (using a slave battery for starting), do not, under any circumstances, interrupt the circuit by switching off the main switch before stopping the engine by means of the fuel pump shut-off cable. Further it is recommended to use additional current (lights) while engine is running. Do not run engine at a speed above 1000 rpm. Insulate battery end of disconnected starter cable properly to avoid damage to alternator and regulator.

On tractors with operator's cab: Do not connect ground strap of slave battery to cab.

2. Connect batteries or battery charger in the proper polarity ("+" and "-"). If they are improperly connected, the rectifier diodes will be immediately destroyed.

START SAFETY SWITCH

1. Move range shift lever into neutral or "park"* position.
2. Check function of start safety switch. Replace switch when necessary (see Section 40, Group 15).

LIGHTING SYSTEM

1. Check lighting system and repair if necessary. Replace any defective bulbs (see Section 40, Group 20).
2. Check headlight adjustment and correct, if necessary (see Section 40, Group 20).

OPERATOR'S CAB CONTROLS

Fan Switch

Open air outlets. Check fan switch 2 (fig. 4 or 5) for proper operation.

Heater Switch

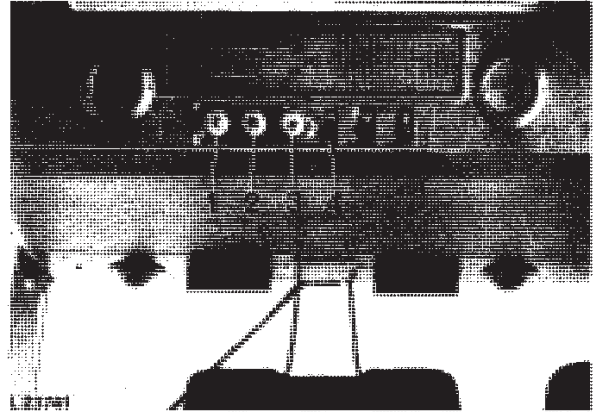

Fig. 4 — Operator's Cab Controls (OPU Cab)

- | | |
|-----------------|-------------------------------------------|
| 1 Heater switch | 3 Thermostat switch
(air conditioning) |
| 2 Fan switch | 4 Windshield wiper switch |

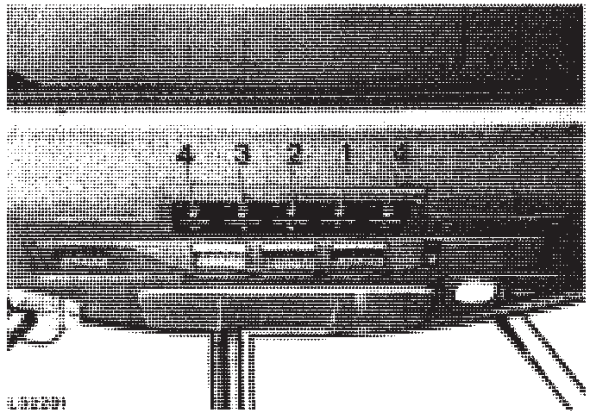

Fig. 5 — Operator's Cab Controls (SG2 Cab)

- | | |
|-----------------|-------------------------------------------|
| 1 Heater switch | 3 Thermostat switch
(air conditioning) |
| 2 Fan switch | 4 Windshield wiper switch |

* On tractors equipped with collar shift transmission and parking lock only.

With fan operating, check heater switch 1 (fig. 4 or 5) for proper operation. For this purpose, turn switch on tractors equipped with OPU cab to the left and with SG2 cab to the right. Making sure that warm air enters cab (with engine at operating temperature).

Thermostat Switch (Tractors with Air Conditioning)

With fan operating, check infinitely variable thermostat switch (if equipped) for proper operation. Turn off heater. Turn thermostat switch 3 clockwise, making sure cool air enters cab. If switch does not operate correctly, see Section 90, Group 05.

Windshield Wiper Switch

Check windshield wiper switch for proper operation.

CONTROLS AND INSTRUMENTS

Check controls and instruments for proper operation.

NOTE: On tractors equipped with collar shift transmission: Transmission oil pressure indicator light will glow only when a malfunction occurs.

Power Train

CHECKING TRANSMISSION/HYDRAULIC SYSTEM OIL LEVEL

1. With the tractor on level ground, run the engine 2 to 3 minutes.
2. Place range and gear shift lever in neutral position.
3. Apply handbrake.
4. Lower draft links.
5. Run engine at slow idle (700 to 800 rpm).
6. Pull out dipstick and wipe clean.
7. Insert dipstick. Remove dipstick and check oil level.

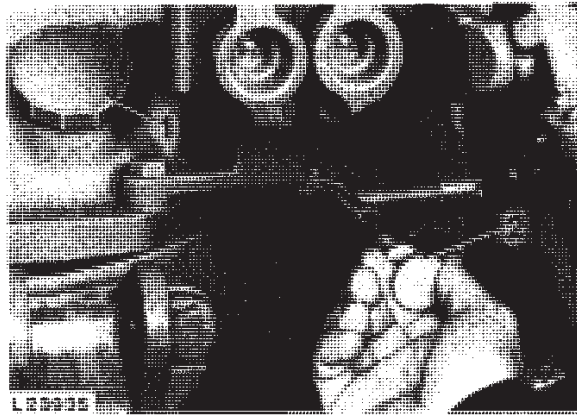

Fig. 6 — Transmission/Hydraulic System Dipstick and Filler Cap

- 1 Filler cap
- 2 Dipstick

8. If necessary, add John Deere Hy-Gard Transmission and Hydraulic Oil or equivalent oil to bring oil level to top mark on dipstick.

NOTE: Types of oil not meeting our specifications will not give satisfactory service and may result in eventual damage.

TRANSMISSION

1. Check transmission for proper operation.
2. While driving tractor, shift transmission through all gears. If transmission does not function properly, refer to Section 50, Group 30 and 35 or 40.

DIFFERENTIAL LOCK

Check differential lock for proper operation. If you find any problem refer to Section 50, Group 45.

INDEPENDENT PTO

1. Check PTO operation. For this purpose, run engine and move PTO control lever to engaged and disengaged position. If PTO does not operate properly, refer to Section 50, Group 55.