

Product: John Deere JD450B Crawler Tractor Service Repair Technical Manual  
Full Download: <https://www.bobmanualstore.com/downloads/john-deere-jd450b-crawler-tractor-service-repair-technical-manual/>



# John Deere JD450B Crawler Tractor



JOHN DEERE

## TECHNICAL MANUAL

John Deere JD450B  
Crawler Tractor

TM1033 (01MAY87) English

**John Deere Dubuque Works**  
**TM1033 (01MAY87)**

Sample manual. Download All 332 pages at: LITHO IN U.S.A.  
ENGLISH  
<https://www.bobmanualstore.com/downloads/john-deere-jd450b-crawler-tractor-service-repair-technical-manual/>



Product: John Deere JD450B Crawler Tractor Service Repair Technical Manual  
Full Download: <https://www.bobmanualstore.com/downloads/john-deere-jd450b-crawler-tractor-service-repair-technical-manual/>

# JD450-B CRAWLER TRACTORS AND CRAWLER LOADERS

Technical Manual  
TM-1033 (May-87)

## CONTENTS

### SECTION 10 - GENERAL

- Group 5 - Specifications
- Group 10 - Predelivery, Delivery, and After-Sales Services
- Group 15 - Tune-up and Adjustment
- Group 20 - Lubrication
- Group 25 - Separation

### SECTION 20 - ENGINE

- Group 5 - Diagnosis
- Group 10 - Basic Engine
- Group 15 - Engine Lubrication System
- Group 20 - Speed Control Linkage
- Group 25 - Engine Cooling System
- Group 30 - Specifications and Special Tools

### SECTION 30 - FUEL SYSTEM

- Group 5 - Diagnosis
- Group 10 - Fuel Tank, Transfer Pump and Filters
- Group 15 - Air Intake System
- Group 20 - Fuel Injection Pump

### SECTION 40 - ELECTRICAL SYSTEM

- Group 5 - Description and Electrical Schematic
- Group 10 - Charging System
- Group 15 - Starting Motor
- Group 20 - Gauges and Switches

### SECTION 50 - POWER TRAIN

- Group 5 - Diagnosis
- Group 10 - Clutch Assembly
- Group 15 - H-L-R Transmission
- Group 20 - Power Take-off and Winch Drive
- Group 25 - Specifications and Special Tools

*The specifications and design information contained in this manual were correct at the time it was printed. It is John Deere's policy to continually improve and update our machines. Therefore, the specifications and design information are subject to change without notice.*

### SECTION 60 - STEERING AND BRAKES

- Group 5 - General Information, Testing and Diagnosis
- Group 10 - Power Steering Pump
- Group 15 - Power Steering Cylinders and Reservoir
- Group 20 - Final Drive Assembly
- Group 25 - Steering and Brake Assembly

### SECTION 70 - HYDRAULIC SYSTEM

- Group 5 - General Information, Testing, and Diagnosis
- Group 10 - Hydraulic Components
- Group 15 - Hydraulic Pump
- Group 20 - Loader Control Valve
- Group 25 - Dozer Control Valve
- Group 30 - Backhoe Control Valve
- Group 35 - Hydraulic Cylinders
- Group 40 - Backhoe Swing Cylinder

### SECTION 80 - MISCELLANEOUS COMPONENTS

- Group 5 - Tracks
- Group 10 - Track Carrier Assembly
- Group 15 - Winch System
- Group 20 - Dozer Frames and Blades
- Group 25 - Loader Frame, Boom, and Bucket
- Group 30 - Drott 4-in-1 Bucket
- Group 35 - Lumber Fork and Pulpwood Loader
- Group 40 - Backhoe Boom and Bucket

### INDEX

Copyright® 1987  
DEERE & COMPANY  
Moline, Illinois  
All rights reserved  
Previous Editions

Copyright® 1980 Deere & Company  
Copyright® 1974 Deere & Company  
Copyright® 1973 Deere & Company  
Copyright® 1972 Deere & Company  
Copyright® 1971 Deere & Company  
Copyright® 1970 Deere & Company

## INTRODUCTION

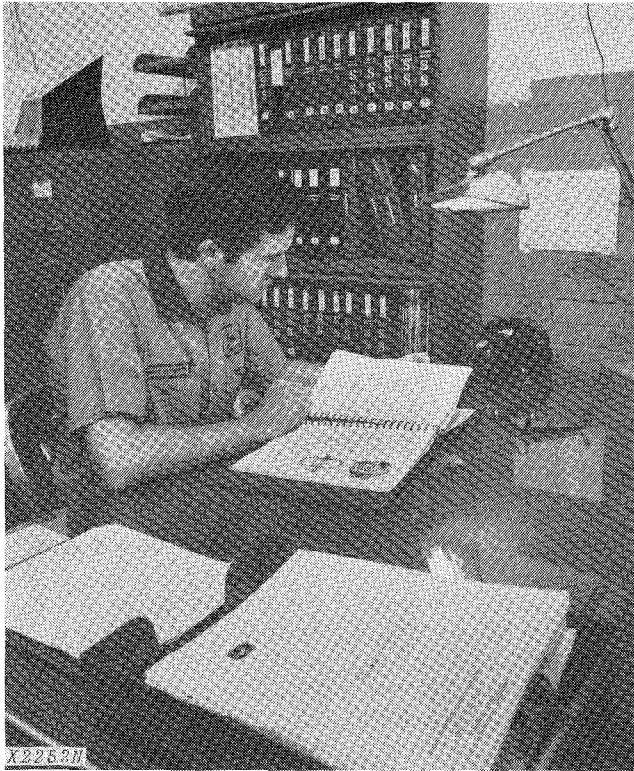

Use FOS Manuals for Reference

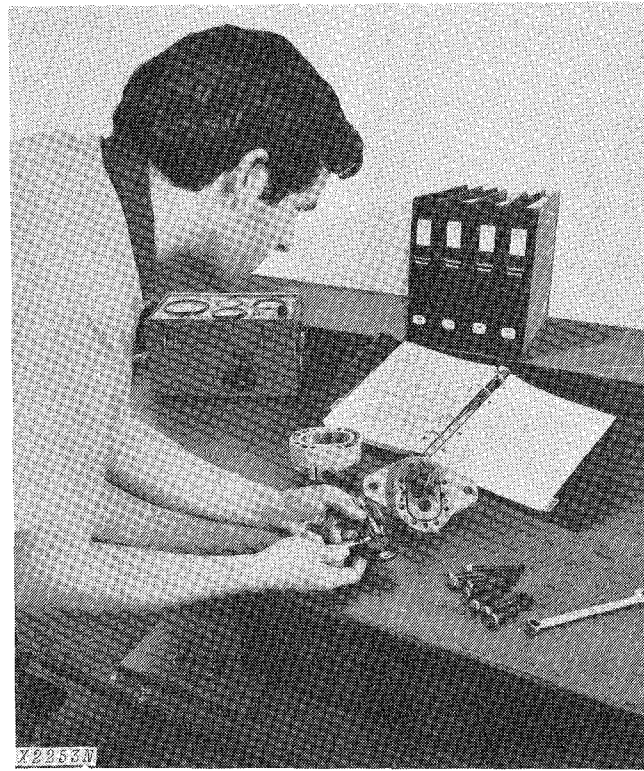

Use Technical Manuals for Actual Service

This technical manual is part of a twin concept of service:

The two kinds of manuals work as a team to give you both the general background and technical details of shop service.

### •FOS Manuals—for reference

*Fundamentals of Service (FOS) Manuals* cover basic theory of operation, *fundamentals* of trouble shooting, *general* maintenance, and *basic* types of failures and their causes. FOS Manuals are for training new personnel and for reference by experienced service technicians.



When a service technician should refer to a FOS Manual for more information, a FOS symbol like the one at the left is used in the TM to identify the reference.

### •Technical Manuals—for actual service

*Technical Manuals* are concise service guides for a *specific* machine. Technical manuals are on-the-job guides containing only the vital information needed by an experienced service technician.

This technical manual was planned and written for you—an experienced service technician. Keep it in a permanent binder in the shop where it is handy. Refer to it whenever in doubt about correct service procedures or specifications.

Some features of this manual:

- *Table of contents at front of manual*
- *Exploded views showing parts relationship*
- *Photos showing service techniques*
- *Specifications grouped for easy reference*

 This safety alert symbol identifies important safety messages in this manual. When you see this symbol, be alert to the possibility of personal injury and carefully read the message that follows.

### COMPLETE PAGE LISTING WITH LATEST DATE LINES

1, 2	(Oct-80)	40-5-1, 2	(Nov-73)
3, 4	(Oct-80)	40-5-3, 4	(Nov-73)
10-5-1, 2	(May-73)	40-5-5, 6	(Oct-80)
10-5-3, 4	(Oct-80)	40-5-7, 8	(Nov-73)
10-10-1, 2	(May-73)	40-5-9, 10	(Oct-80)
10-10-3, 4	(Dec-71)	40-10-1, 2	(Oct-80)
10-15-1, 2	(Dec-71)	40-10-3, 4	(Oct-80)
10-15-3, 4	(Dec-71)	40-10-5, 6	(Feb-74)
10-20-1, 2	(Nov-72)	40-10-7, 8	(Aug-73)
10-25-1, 2	(Oct-80)	40-10-9, 10	(Apr-74)
10-25-3, 4	(Feb-74)	40-10-11, 12	(Oct-80)
10-25-5, 6	(Oct-80)	40-15-1, 2	(May-73)
10-25-7, 8	(Oct-80)	40-15-3, 4	(Aug-74)
10-25-9, 10	(Oct-80)	40-15-5, 6	(May-73)
10-25-11, 12	(Oct-80)	40-15-7, 8	(May-73)
20-5-1, 2	(Oct-80)	40-20-1, 2	(Oct-80)
20-10-1, 2	(Oct-80)	50-5-1,2	(Oct-80)
20-10-3, 4	(Oct-80)	50-10-1, 2	(Nov-70)
20-10-5, 6	(Apr-74)	50-10-3, 4	(Oct-80)
20-10-7, 8	(Oct-80)	50-10-5, 6	(Oct-80)
20-10-9, 10	(Oct-80)	50-10-7, 8	(Dec-71)
20-10-11, 12	(Oct-80)	50-15-1, 2	(Dec-71)
20-10-13, 14	(Dec-71)	50-15-3, 4	(Dec-71)
20-10-15, 16	(Dec-71)	50-15-5, 6	(Dec-71)
20-15-1, 2	(Oct-80)	50-15-7, 8	(Dec-71)
20-15-3, 4	(Oct-80)	50-15-9, 10	(Dec-71)
20-20-1, 2	(Oct-80)	50-15-11, 12	(Nov-72)
20-25-1, 2	(May-73)	50-15-13, 14	(Dec-71)
20-25-3, 4	(Oct-80)	50-15-15, 16	(Nov-72)
20-30-1, 2	(Oct-80)	50-15-17, 18	(Nov-72)
20-30-3, 4	(Oct-80)	50-15-19, 20	(Nov-72)
20-30-5, 6	(Oct-80)	50-15-21, 22	(Nov-72)
20-30-7, 8	(Oct-80)	50-15-23, 24	(Dec-71)
30-5-1, 2	(Dec-71)	50-15-25, 26	(Nov-72)
30-10-1, 2	(Nov-72)	50-15-27, 28	(Feb-74)
30-10-3, 4	(Dec-71)	50-15-29, 30	(Feb-74)
30-15-1, 2	(Oct-80)	50-15-31, 32	(Oct-80)
30-15-3, 4	(Oct-80)	50-15-33, 34	(Feb-74)
30-15-5, 6	(Oct-80)	50-15-35, 36	(Dec-71)
30-15-7, 8	(Oct-80)	50-15-37, 38	(Feb-74)
30-20-1, 2	(Oct-80)	50-20-1, 2	(Dec-71)
30-20-3, 4	(Oct-80)	50-20-3, 4	(Dec-71)
30-20-5, 6	(Oct-80)	50-25-1, 2	(Oct-80)

| Vertical lines indicate pages included in this revision.

60-5-1, 2	(Nov-72)	80-5-1, 2	(Oct-80)
60-5-3, 4	(Dec-71)	80-5-3, 4	(Dec-71)
60-10-1, 2	(Feb-73)	80-5-5, 6	(Oct-80)
60-10-3, 4	(Nov-70)	80-5-7, 8	(Oct-80)
60-15-1, 2	(Nov-70)	80-5-9, 10	(Oct-80)
60-15-3, 4	(Oct-80)	80-5-11, 12	(Oct-80)
60-20-1, 2	(Oct-80)	80-5-13, 14	(Oct-80)
60-20-3, 4	(Oct-80)	80-5-15, 16	(Oct-80)
60-20-5, 6	(Oct-80)	80-10-1, 2	(Nov-70)
60-25-1, 2	(Oct-80)	80-10-3, 4	(Oct-80)
60-25-3, 4	(Oct-80)	80-10-5, 6	(May-73)
60-25-5, 6	(Oct-80)	80-10-7, 8	(May-73)
60-25-7, 8	(Oct-80)	80-10-9, 10	(May-73)
		80-10-11, 12	(May-73)
		80-10-13, 14	(Oct-80)
70-5-1, 2	(Nov-72)	80-15-1, 2	(Nov-70)
70-5-3, 4	(Nov-70)	80-15-3, 4	(Oct-80)
70-5-5, 6	(Oct-80)	80-15-5, 6	(Nov-72)
70-5-7, 8	(Nov-70)	80-15-7, 8	(Oct-80)
70-5-9, 10	(Oct-80)	80-15-9, 10	(Nov-72)
70-5-11, 12	(Oct-80)	80-15-11, 12	(Nov-73)
70-10-1, 2	(Nov-73)	80-15-13, 14	(Feb-73)
70-10-3, 4	(Nov-70)	80-15-15, 16	(Feb-73)
70-10-5, 6	(Dec-71)	80-15-17, 18	(Oct-80)
70-15-1, 2	(Nov-70)	80-20-1, 2	(Nov-70)
70-15-3, 4	(Oct-80)	80-20-3, 4	(Oct-80)
70-20-1, 2	(Nov-70)	80-25-1, 2	(Nov-70)
70-20-3, 4	(Nov-70)	80-25-3, 4	(Oct-80)
70-20-5, 6	(Aug-74)	80-30-1, 2	(Oct-80)
70-20-7, 8	(Oct-80)	80-35-1, 2	(Nov-70)
70-20-9, 10	(Nov-73)	80-40-1, 2	(Aug-73)
70-25-1, 2	(Nov-70)	80-40-3, 4	(Feb-74)
70-25-3, 4	(Nov-72)	80-40-5, 6	(Feb-74)
70-25-5, 6	(Nov-72)		
70-25-7, 8	(Nov-72)		
70-30-1, 2	(Oct-80)	Index-1, 2	(Oct-80)
70-30-3, 4	(Dec-71)	Index-3, 4	(Oct-80)
70-30-5, 6	(Oct-80)	Index-5, 6*	(May-73)
70-35-1, 2	(Feb-74)		
70-35-3, 4	(Feb-74)		
70-35-5, 6	(Feb-74)		
70-35-7, 8	(Oct-80)		
70-40-1, 2	(Nov-70)		
70-40-3, 4	(Oct-80)		
70-40-5, 6	(Aug-73)		

| Vertical lines indicate pages included in this revision.

\*Remove these pages from Technical Manual.

# Section 10 GENERAL

## CONTENTS OF THIS SECTION

	Page		Page
GROUP 5 - SPECIFICATIONS .....	5-1	Transmission Hydraulic Oils .....	20-2
GROUP 10 - PREDELIVERY, DELIVERY, AND AFTER-SALES SERVICES		Greases .....	20-2
Predelivery Service .....	10-1	Storing Lubricants .....	20-2
Delivery Service .....	10-3	GROUP 25 - SEPARATION	
After-Sales Service .....	10-3	Removal and Installation	
GROUP 15 - TUNE-UP AND ADJUSTMENT		Engine .....	25-1
Preliminary Engine Testing .....	15-1	Clutch Housing .....	25-2
Engine Tune-Up .....	15-1	Final Drives .....	25-3
Final Engine Test .....	15-3	Steering Clutches .....	25-4
Crawler Adjustments .....	15-3	Transmission .....	25-7
GROUP 20 - LUBRICATION		Loader .....	25-8
Lubrication Chart (capacities and lubricants) .....	20-1	9250, 9300 Backhoe .....	25-9
Engine Lubricating Oils .....	20-2	Torque Values .....	25-10
		Special Tools .....	25-11

## Group 5 SPECIFICATIONS

### Engine

Type..... 4-cylinder in-line, valve-in-head,  
 4-stroke cycle diesel

Flywheel horsepower  
 (observed) at 2500 rpm ..... 65  
 Drawbar horsepower  
 (observed) ..... 48.6  
 Torque (ft-lbs) max. at 1300  
 rpm (observed)  
 (nominal) ..... 164.5  
 Bore and stroke, inches ..... 4.02 x 4.33  
 Displacement, cubic  
 inches ..... 219  
 Compression ratio ..... 16.2:1  
 Firing order ..... 1,3,4,2

Governed speed range (rpm) ..... 800 - 2650  
 Engine disconnect clutch ..... 11-inch, single disk,  
 foot-operated

### Electrical System

Battery voltage  
 (nominal) ..... 12 volts  
 Ground battery terminal ..... Negative

### Hydraulic System

Type.... Open-center; includes power steering,  
 brakes, loader, dozer, ripper, backhoe,  
 and rotoboom.

### Transmission

Type ..... Manual selection, H-L-R with eight forward speeds and four reverse  
Travel speeds, mph (no slip, 2500 engine rpm):

Range	High	Low	Reverse
1st	1.8	1.3	1.7
2nd	2.8	2.0	2.7
3rd	4.3	3.0	4.1
4th	6.7	4.7	6.4

### Steering-Brakes

Type ..... Multiple-disk clutches and contracting band with integral reservoir (early models), hydraulic pump and cylinders.

### Power Take-Off

Type .... Transmission-driven, rear, 1000 rpm at 1900 rpm engine speed.

### Track and Track Frame

Five rollers non-oscillating, one carrier roller each side. Hydraulic track adjusters. 36 track shoes per side (Dozer). 37 track shoes per side (Loader).

### Track Shoes

Type	Size (Inches)
Grouser	14, 16, 18
Rubber	13
Notched Open-Center Grouser	16
Triple Semi-Grouser	13, 14, 16
Open Center Grouser	14, 16, 18

### Capacities (U.S. Standard Measures)

Fuel tank	31 gal.
Cooling system	16 qts.
Engine crankcase (including filter)	9 qts.
Transmission case	32 qts.
Final drives (each)	6.5 qts.
Crawler loader hydraulic system	13 gal.
(with fork and single clamp)	15 gal.
(with fork and dual clamps)	16 gal.
Crawler tractor hydraulic system	8 gal.
Winch housing reservoir	9 qts.
Winch drum:	
(with 1/2-inch cable)	195 ft.
(with 5/8-inch cable)	125 ft.
(with 3/4-inch cable)	100 ft.

### Weight Distribution

	Loader	Bulldozers		
		6405	6410	6415
SAE Operating Weight (lbs.)*	16,700	14,250	14,250	14,500
Ground Contact (Sq. In.)	2,128	2,328	2,328	2,328
Ground Pressure (psi)	7.8	6.1	6.1	6.2
Track on Ground (inches)	76	72.75	72.75	72.75

\* 1973 Representative Tractor  
Includes fully serviced tractor, 175 lb. operator, and R.O.P.S.

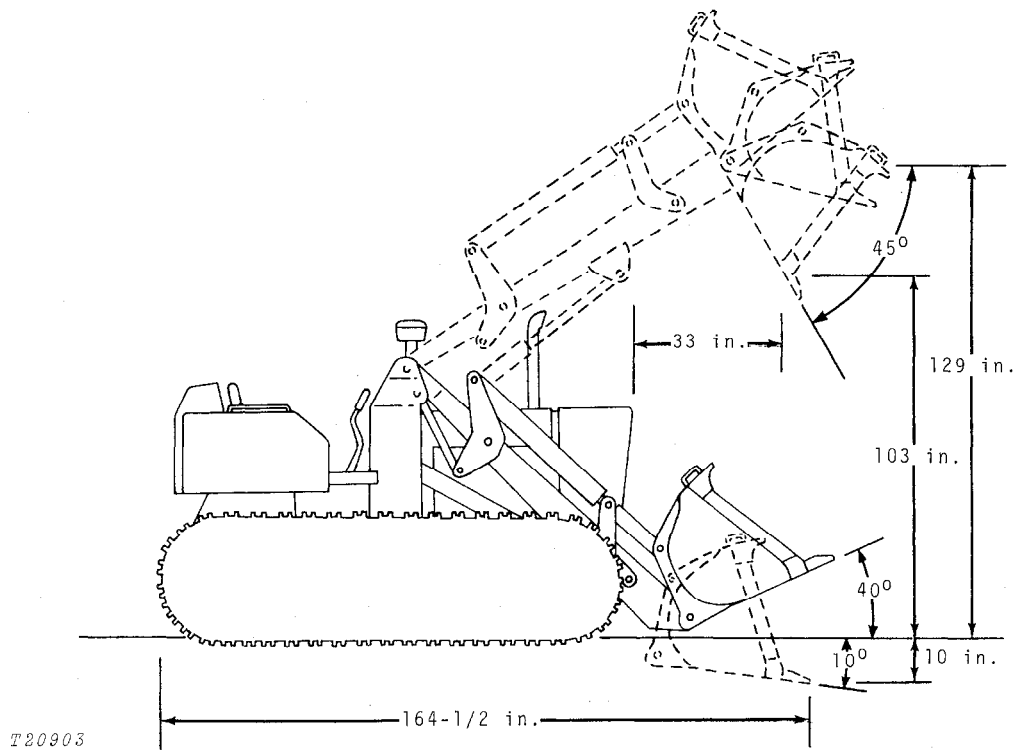

JD450-B Operating Dimensions

**DIMENSIONS (Crawler Tractor)**

Height to top of hood	57 in.
Over-all height (with exhaust stack)	89 in.
Over-all width, minimum (with 14 in. shoes)	65-3/4 in.
Over-all length	109-1/4 in.
Ground clearance (at rear crossbar)	14-1/4 in.
Shipping weight (approx.)	11,600 lbs.

**DIMENSIONS (Crawler Loader)**

Over-all length	164-1/4 in.
Over-all height (with exhaust stack)	89 in.
Over-all width (minimum) (with 14 in. shoes)	72-1/4 in.

Ground clearance (at rear crossbar)	14-1/4 in.
Dumping reach (full height) (bucket at 45° angle)	33 in.
Dumping clearance (full height) (bucket at 45° angle)	103 in.
Maximum lift (bucket at full height)	129 in.
Digging depth below ground (10 degrees)	4-1/2 in.
Bucket width (1-1/4 yd. bucket)	72-1/4 in.
Maximum dump angle	
Full height	50° from horizontal
Ground level	70° from horizontal
Bucket roll-back (ground level)	40°
Operating weight, approximate	16,390 lbs.
Hydraulic lift capacity (full height)	9,000 lbs.
Breakout force	14,360 lbs.



## Group 10

# PREDELIVERY, DELIVERY, AND AFTER-SALES SERVICES

### PREDELIVERY SERVICE

Because of the shipping factors involved, plus extra finishing touches that are necessary to promote customer satisfaction, proper predelivery service is of prime importance to the dealer.

A tag pointing out the factory-recommended procedure for predelivery service is attached to each new crawler before it leaves the factory.

After completing the factory-recommended dealer checks and services listed on the predelivery tag, remove the tag from the crawler and file it with the job shop order. The tag will then serve as a basis for certifying that the crawler has received the proper predelivery service when that portion of the customer's John Deere Delivery Receipt is completed.

### TEMPORARY CRAWLER STORAGE

Service	Specification	Reference
Check radiator for coolant loss and antifreeze protection.	.....	Section 10, Group 15
Fill fuel tank	.....	Operator's Manual
Check crankcase oil level.	.....	Operator's Manual
Relieve hydraulic pressure.	Stop engine, lower equipment to ground. ....	
Cover crawler for protection and cleanliness.	.....	

### BEFORE DELIVERING CRAWLER

#### Electrical System

Inspect electrolyte	.....	Operator's Manual
Check alternator belt tension	3/4-inch deflection with 20 lb. force.	Operator's Manual
Clean terminals and check battery cable connections.	.....	Operator's Manual

#### Cooling System

Inspect radiator for coolant loss.	Midway between core and filler neck.	Operator's Manual
Check antifreeze protection.	.....	Operator's Manual

#### Track

Check track tension.	.....	Section 80
Check front idler, track carrier roller and track roller oil level.	To oil level check hole.	.....

#### Lubrication

Check crankcase oil level.	Between marks on dipstick.	Operator's Manual
Check transmission oil level.	Between marks on gauge.	Operator's Manual

**BEFORE DELIVERING CRAWLER (Continued)**

Service	Specification	Reference
<b>Lubrication (Continued)</b>		
Check final drive oil level.	To level of filler holes.	Operator's Manual
Check hydraulic reservoir oil level.	Halfway up on window glass	Operator's Manual
Check winch reservoir oil level.	To level of oil level hole.	Operator's Manual
Lubricate grease fittings.	.....	Operator's Manual
<b>Engine</b>		
Check air cleaner.	.....	Operator's Manual
Fill fuel tank and start engine.	.....	Operator's Manual
Check operation of lights and gauges.	.....	Operator's Manual
Check speed control linkage for free operation.	.....	Section 20
Check engine idle speeds.	.....	Section 20
<b>Operation</b>		
Check engine clutch operation.	.....	Section 50
Check brake operation.	.....	Section 60
Shift transmission through all ranges.	.....	Operator's Manual
Check power take-off operation.	.....	Operator's Manual
Check operation of attached equipment.	.....	Operator's Manual
Check hydraulic system operation.	.....	Operator's Manual
Check steering operation.	.....	Section 60
Check bucket level indicator and electrical return-to-dig mechanism (if present).	.....	Operator's Manual
<b>General</b>		
Tighten accessible nuts and cap screws.	Standard torque chart.	Section 10
Clean crawler and touch up paint.	.....	.....

## DELIVERY SERVICE

A thorough discussion of the operation and service of a new machine at the time of delivery helps to assure complete customer satisfaction. Proper delivery should be an important phase of a dealer's program. A portion of the John Deere Delivery Receipt emphasizes the importance of proper delivery service.

It is a well-known fact that many complaints have arisen simply because the owner was not shown how to operate and service his new machine properly. Enough time should be devoted, at the customer's convenience, to introducing the owner to his new machine and explaining to him how to operate and service it.

Using the machine operator's manual as a guide, be sure that the owner understands these points thoroughly:

1. Controls and instruments.
2. How to start and stop the engine.
3. The importance of the break-in period.
4. How to use cast-iron ballast.
5. All functions of the hydraulic system.
6. The importance of safety.
7. The importance of lubrication and periodic services.

After explaining and demonstrating the above features, have the owner sign the delivery receipt and give him the operator's manual.

## AFTER-SALES SERVICE

The purchaser of a new John Deere machine is entitled to a free inspection at some mutually agreeable time within the warranty period after the equipment has been "run in."

The purpose of this inspection is to make sure that the customer is receiving satisfactory performance from his machine. At the same time, the inspection should reveal whether or not the machine is being operated, lubricated, and serviced properly.

If the recommended after-sales service inspection is followed, the dealer can eliminate a needless volume of service work by preventing minor irregularities from developing into service problems later on. This will promote strong dealer-customer relations and give the dealer an opportunity to answer questions that may have arisen during the first few days of operation. During the inspection service, the dealer has the additional opportunity of promoting the possible sales of other new equipment.

The following is a recommended inspection program.

## INSPECTION PROCEDURE

Service	Specification	Reference
<b>Cooling System</b>		
Check radiator coolant level.	Midway between core and filler neck	Operator's Manual
Check external surface of radiator core.	.....	Operator's Manual
Check hoses and connections for leaks.	.....	.....
<b>Fuel System</b>		
Remove water and foreign matter from fuel filter sediment bowls.	.....	Operator's Manual
Bleed fuel system.	.....	Operator's Manual
Tighten loose connections and check entire system for leaks. Correct if necessary	.....	.....
Check air cleaner cup, element, and unloading valve. Clean element if necessary.	.....	Operator's Manual

**INSPECTION PROCEDURE—Continued**

Service	Specification	Reference
<b>Electrical System</b>		
Check specific gravity of battery.	1.215 to 1.270 at 80°F	Operator's Manual
Check level of battery electrolyte.	To bottom of filler neck above plates.	Operator's Manual
Check alternator belt tension.	3/4-inch deflection with 20-pound force.	Operator's Manual
Start engine and check action of starter, lights and gauges.	.....	Operator's Manual
<b>Lubrication</b>		
Check crankcase oil level.	Between marks on dipstick	Operator's Manual
Check transmission oil level.	Between marks on gauge.	Operator's Manual
Check final drive oil level.	To level of filler holes.	Operator's Manual
Check hydraulic reservoir oil level.	Halfway up on window glass.	Operator's Manual
Check winch reservoir oil level.	To level of oil level hole.	Operator's Manual
Lubricate grease fittings.	.....	Operator's Manual
<b>Engine</b>		
Check valve clearance.	Intake-0.014 inch Exhaust-0.018 inch	Operator's Manual
Check engine speed under load and horsepower (Dynamometer test).	65 hp at 2500 rpm	FOS-ENGINES
<b>General</b>		
Check clutch pedal free travel.	.....	Operator's Manual
Check transmission linkage adjustment.	.....	Section 50
Check power take-off operation.	.....	Operator's Manual
Check hydraulic system.	.....	Section 70
Check steering clutches and brakes.	.....	Section 60
Check track tension.	.....	Section 80
Check winch operation.	.....	Section 80
Tighten accessible nuts and cap screws.	.....	Section 10, Group 25

## Group 15

# TUNE-UP AND ADJUSTMENT

Before tuning up a tractor, determine whether a tune-up will restore operating efficiency. When there is doubt, the following preliminary tests will help to determine if the engine can be tuned up. If the condi-

tion is satisfactory, proceed with the tune-up. Choose from the following procedures only those necessary to restore the unit.

### PRELIMINARY ENGINE TESTING

Operation	Specification	Reference
Dynamometer Test (at 2500 engine rpm) . . .	Compare with "SPECIFICATIONS"; compare with output after tune-up.	FOS-ENGINES
Compression Test . . . . .	350 psi. The difference between cylinders should be no more than 50 psi.	FOS-ENGINES
Intake Vacuum Test . . . . .	11 to 25 inches of water at fast idle	FOS-ENGINES
Engine Coolant Check . . . . .	No air bubbles or oil film in radiator	FOS-ENGINES

### ENGINE TUNE-UP

Operation	Specification	Reference
<b>Air Intake System</b>		
Service air cleaner and check system for leaks . . . . .		FOS-ENGINES
Check restriction indicator operation . . . . .	23 to 27 inches of water at 2500 rpm (full load)	FOS-ENGINES
Check crankcase breather for restriction . . . . .		FOS-ENGINES
<b>Exhaust System</b>		
Check system for leaks . . . . .		FOS-ENGINES
Check muffler and exhaust pipe for restriction . . . . .		FOS-ENGINES
<b>Cooling System</b>		
Check radiator for coolant loss . . . . .	Midway between core and filter neck . . . . .	
Clean grille, radiator core and oil cooler case . . . . .		FOS-ENGINES
Check pressure cap . . . . .	6.25 to 7.50 psi release pressure	FOS-ENGINES
Clean and flush system, check thermostat.	Starts to Open	Fully Open
180° . . . . .	177°F. to 184°F.	202°F.
205° . . . . .	201°F. to 207°F.	213°F.

## ENGINE TUNE-UP—Continued

Operation	Specification	Reference
<b>Cylinder Head and Valves</b>		
Tighten cylinder head cap screws . . . . .	110 ft.-lbs. torque, in sequence	Section 20, Group 10
Check valve clearance . . . . .	Intake, 0.014-inch Exhaust, 0.018-inch	Section 20, Group 10
<b>Fuel System</b>		
Check fuel tank sump for water . . . . .		FOS - ENGINES
Check fuel transfer pump pressure . . . . .	3-1/2 to 4-1/2 psi at slow idle	FOS - ENGINES
Clean sediment bowls and change filter . . . . .		FOS - ENGINES
Service injection nozzles . . . . .		SM-2045
Injection Pump:		
Service and check timing . . . . .		Section 30, Group 25
Advance . . . . .		Section 30, Group 25
Adjust throttle linkage . . . . .	Slow idle (rpm) 800 Fast idle (rpm) 2650	Section 20, Group 20
Lubrication System		
Check engine oil pressure . . . . .	45 to 65 psi at 2500 rpm (180°F. to 220°F.)	Section 20, Group 10
<b>Charging System</b>		
Check battery specific gravity . . . . .		FOS - ELECTRICAL SYSTEMS
Check electrolyte level . . . . .		FOS - ELECTRICAL SYSTEMS
Check alternator belt tension . . . . .	3/4-inch belt deflection with 20 lbs. force.	FOS - ELECTRICAL SYSTEMS
Check alternator output . . . . .	22 amps.	FOS - ELECTRICAL SYSTEMS
Check alternator regulated voltage . . . . .		FOS - ELECTRICAL SYSTEMS
<b>Starting System</b>		
Check start-safety switch operation . . . . .		FOS - ELECTRICAL SYSTEMS
Check starter current draw . . . . .	Approx. 150 amps.	Section 40, Group 15
Check operation of ammeter, oil pressure and air filter restriction indicator . . . . .		FOS - ELECTRICAL SYSTEMS

### FINAL ENGINE TEST

Operation	Specification	Reference
Dynamometer .....	Compare with previous recorded output. Record for future use.	FOS - ENGINES

### CRAWLER ADJUSTMENTS

Operation	Specification	Reference
Engine clutch pedal adjustment .....		Section 50, Group 10
Steering clutch adjustment .....		Section 60, Group 25
Steering linkage adjustment .....		Section 60, Group 25
Brake band adjustment .....		Section 60, Group 25
Foot brake linkage adjustment .....		Section 60, Group 25
Track adjustment .....		Section 80, Group 10
Track alignment .....		Section 80, Group 10
H-L-R system adjustment .....		Section 50, Group 20
Winch Adjustments:		
Control lever .....	1/2-inch between front edge of lever and top edge of lever guard	Section 80, Group 15
Brake band .....	4-11/16 inches between bottom edge of spring pin and bottom edge of spring anchor	Section 80, Group 15
Loader Adjustments:		
Bucket level indicator .....		Section 80, Group 25
Electric return-to-dig .....		Section 70, Group 20
Boom alignment .....		Section 80, Group 25
Loader hydraulic system .....		Section 70, Group 5



## Group 20 LUBRICATION

### GENERAL INFORMATION

Carefully written and illustrated lubrication instructions have been included in the operator's manual furnished with your customer's machine. Remind him to follow these instructions carefully.

For your convenience when servicing the crawler, the following chart shows the capacities and types of lubricant for each of the various components and systems. A definition of the various lubricants follows the chart.

Component	Capacity	Type of Lubricant
Engine crankcase	9 U.S. quarts (includes filter)	See "Engine Lubricating Oil" page 20-2
Transmission	32 U.S. quarts	John Deere Type 303 Special-Purpose Oil or an equivalent
Hydraulic system	13 U.S. gallons (min.)	John Deere Type 303 Special-Purpose Oil or an equivalent
Track adjuster (Track tension)	As required	John Deere Track Idler and Roller Lubricant (Type "O") or an equivalent
Loader boom and bucket cylinder pivot points	2 strokes of grease gun	John Deere Multi-Purpose Lubricant or an equivalent
Winch fairlead	2 strokes of grease gun	John Deere Multi-Purpose Lubricant or an equivalent
Loader control lever	As required	Engine oil
Winch housing reservoir	9 U.S. quarts	Above 32°F.: John Deere Type 303 Special-Purpose Oil. Below 32°F.: SAE 5W-20 Oil. Below 0°F.: Three parts SAE 5W-20, one part Grade No. 1 diesel fuel
Final drives	6-1/2 U.S. quarts (each)	John Deere Type 303 Special-Purpose Oil or an equivalent
Starter	Saturate wicks	SAE 10W engine oil
Engine clutch bearing (early models)	2 strokes of grease gun	High temperature grease

## LUBRICANTS

Effective use of lubricating oils and greases is perhaps the most important step towards low upkeep cost, long tractor life, and satisfactory service. Use only lubricants specified in this section; apply them at intervals and according to the instructions in the lubrications and periodic service section.

### ENGINE LUBRICATING OILS



We recommend John Deere Torq-Gard or Torq-Gard Supreme engine oil for use in the engine crankcase. This oil is compounded specifically for use in John Deere engines, and provides superior lubrication under all conditions. NEVER PUT ADDITIVES IN THE CRANKCASE. Torq-Gard oil is formulated to provide all the protection your engine needs. Additives could reduce this protection rather than help it.

If oil other than Torq-Gard or Torq-Gard Supreme is used, it must conform to the following specifications.

#### SINGLE VISCOSITY OILS

API Service CD/SD  
MIL-L-2104C\*  
Series 3\*

#### MULTI-VISCOSITY OILS

API Service CC/SE, CC/SD or SD

\* As further assurance of quality, the oil should be identified as suitable for API Service Designation SD.

Depending on the expected prevailing temperature for the fill period, use oil of viscosity as shown in the following chart.

Air Temperature	John Deere Torq-Gard Oil	Other Oils	
		Single Viscosity Oil	Multi-Viscosity Oil
Above 32°F.	SAE 30	SAE 30	Not recommended.
-10°F. to 30°F.* *	SAE 10W-20	SAE 10W	SAE 10W-30
Below -10°F.	SAE 5W-20	SAE 5W	SAE 5W-20

\* \* SAE 5W-20 oil may also be used to insure optimum lubrication at starting, particularly when engine is subjected to -10°F. or lower temperatures for several hours.

Some increase in oil consumption may be expected when SAE 5W-20 or SAE 5W oils are used. Check oil level more frequently.

### TRANSMISSION HYDRAULIC OILS

Use only John Deere Type 303 Special-Purpose Oil or an equivalent in the transmission-hydraulic system. Other types of oil will not give satisfactory service, and may result in eventual damage. This special oil, available from your John Deere dealer, may be used in all weather conditions.

### GREASES

Use John Deere Multi-Purpose Lubricant or an equivalent multi-purpose type grease for all grease fittings. Application of grease as instructed in the lubrication section will provide proper lubrication and will keep contamination out of bearings.

### Track Idler and Roller Grease

Use John Deere Track Idler and Roller Lubricant or an equivalent multi-purpose grease having a NLGI consisting of No. 0.

### STORING LUBRICANTS

Your tractor can operate at top efficiency only if clean lubricants are used. Use clean containers to handle all lubricants. Store them in an area protected from dust, moisture, and other contamination.

## Group 25 SEPARATION

### REMOVING AND INSTALLING LOADER ENGINE

#### Removal

Most service procedures on the engine can be accomplished with the engine in the unit. If the crankshaft is to be removed or in event of a general overhaul, remove the engine as follows:

Detach H-L-R oil filter base from inside of grille housing. Remove hood and grille housing.

Disconnect all the necessary wiring, linkage and lines from both sides of the engine.

Disconnect radiator hoses and remove radiator and pump with support as a unit.

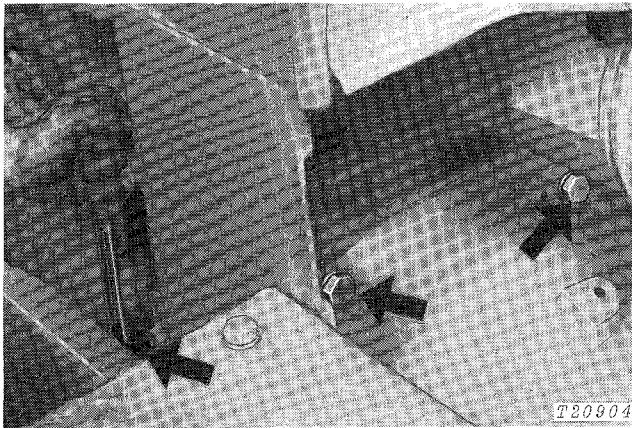

Fig. 1-Engine Attaching Points

Install two JD-244 engine lifting adapters in cylinder head.

Attach JDG-1 sling to lifting adapters.

Remove cap screws securing engine flywheel housing to clutch housing (Fig. 1).

Using hoist, pull engine forward off clutch housing and remove engine from machine.

*NOTE: Alternate method would be to remove the engine, radiator and pump with support as one unit.*

#### Installation

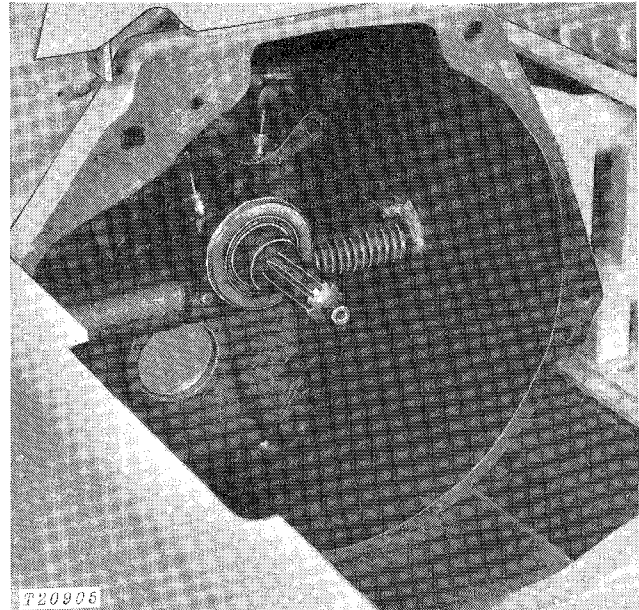

Fig. 2-Transmission-Engine Indexing Point

**IMPORTANT: Tighten side frame-to-steering clutch cap screws before tightening side frame to engine clutch housing cap screws.**

To install engine correctly, line up cap screw holes of engine with those of clutch housing. Bar engine over, holding it in a horizontal position and exerting a steady pressure on the engine toward the clutch housing until the engine clutch indexes with the transmission input shaft.

Refer to specifications, page 10-25-10 for correct cap screw torque values.

Install radiator and hoses. Attach H-L-R oil filter to inside of grille housing.

Connect all the necessary wiring, linkage and lines to both sides of engine.

Start engine and check for oil or water leaks.

## REMOVING AND INSTALLING CLUTCH HOUSING

### Removal

**NOTE:** On crawler-loader units, leave loader and cowl support intact. Remove engine, then drive clutch shaft to right side and remove clutch stop lever. Roll back clutch and brake pedals. Disconnect all wiring and control linkage from clutch housing. Remove cap screws securing clutch housing to cowl support, to side frames, and to transmission. With the aid of a hoist, remove clutch housing by sliding forward off transmission dowels and out under loader and cowl support.

Remove engine from unit as instructed in "Alternate Method" on page 10-25-1.

Disconnect all the necessary wiring, linkage and lines from cowl. Remove cap screws securing cowl to clutch housing and with the aid of a chain hoist, lift cowl from unit.

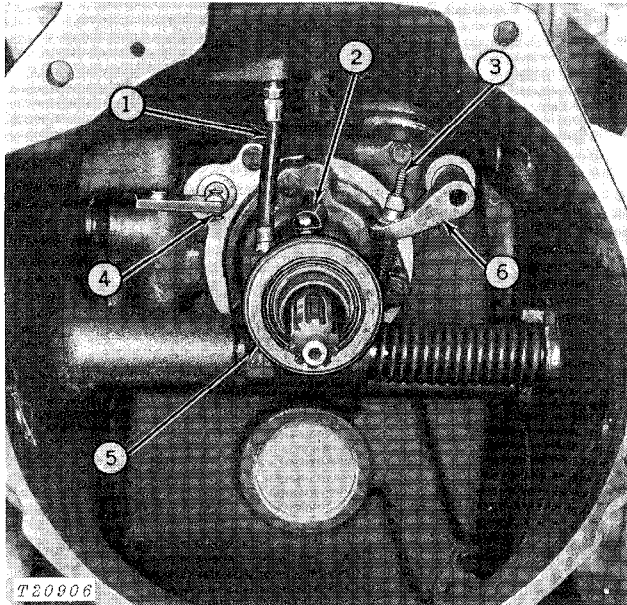

1—Grease Hose ( -133850) 4—PTO Linkage  
2—Return Spring 5—Throw-Out Bearing  
3—Operating Rod 6—H-L-R Operating Arm

Fig. 3-Clutch Control Linkage ( -133850)

Disconnect clutch control linkage (Fig. 3). Remove oil cooler line and elbow from right side of clutch housing-to-transmission front cover.

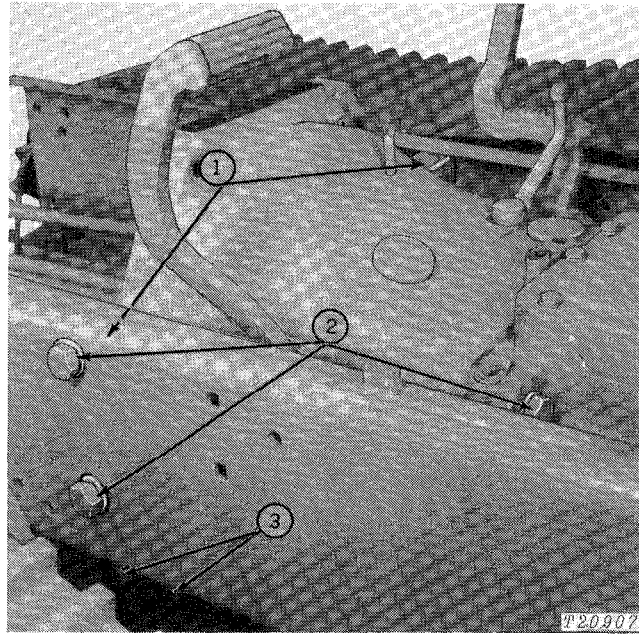

1—Spacer Support 3—Spacer Support  
2—Clutch Housing Attaching Points Attaching Points

Fig. 4-Attaching Points

Disconnect clutch pedal return spring and yokes from brake levers.

Remove cap screws securing clutch housing (Fig. 4) and with the aid of a hoist, remove clutch housing from unit.

### Installation

**IMPORTANT:** Tighten side frame-to-steering clutch cap screws before tightening side frame-to-engine clutch housing cap screws.

Install clutch housing by reversing removal procedure. Spacers are used with lower side frame to clutch housing screws.

Tighten all cap screws to specifications (page 10-25-10).

Install cowl and engine to machine.

## REMOVING AND INSTALLING FINAL DRIVE

### REMOVAL

Raise one side of tractor by placing floor jack securely under front cross member. Start engine and shift transmission into first gear. Pull back on steering lever that controls track not raised off floor (this disengages steering clutch and applies brake to that side). Engage engine clutch, permitting raised track to rotate until master pin has moved around drive sprocket and is approximately 6 inches from floor.

**CAUTION:** Be sure that track to be rotated is clear of floor and opposite track is locked in position so that tractor does not move.

**NOTE:** When crawler is equipped with a loader and bottom counterweight, the counterweight must be removed.

Release track tension, remove track master pin and move track assembly clear of drive sprocket.

Remove sprocket shield or sprocket weight from machine.

A special tool used in the removal and installation of crawler sprocket weights may be produced locally. See "Special Tools", page 10-25-11.

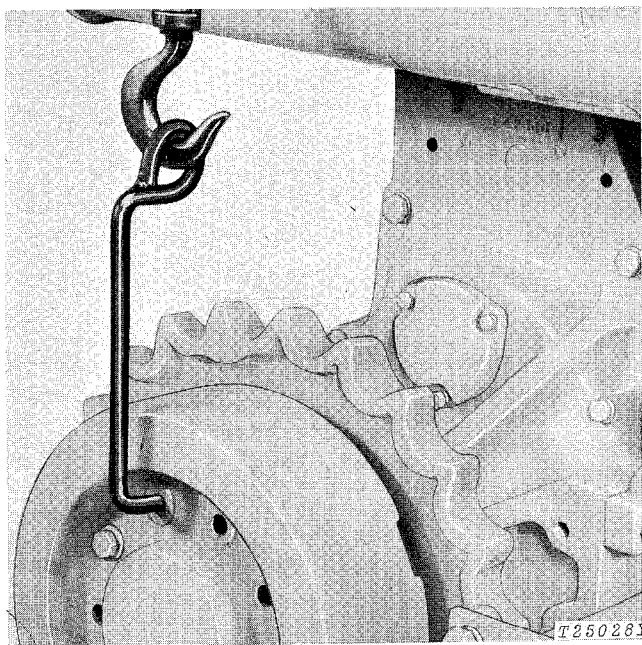
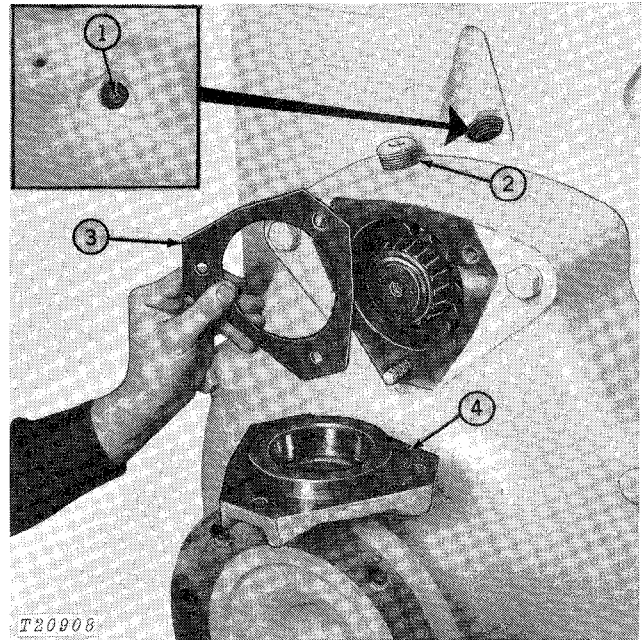

Fig. 5-Removing Sprocket Weight

Position special tool as shown in Fig. 5 to remove or install sprocket weights.

Drain oil from final drive housing and remove track drive sprocket from unit.



- |             |                 |
|-------------|-----------------|
| 1—Set Screw | 3—Shims         |
| 2—Plug      | 4—Bearing Quill |

Fig. 6-Removing Final Drive Pinion Shaft

Remove final drive bearing quill and plug. Rotate steering clutch until set screw is visible in hole and loosen set screw.

Install suitable puller in threaded center hole of final drive pinion shaft and remove shaft.

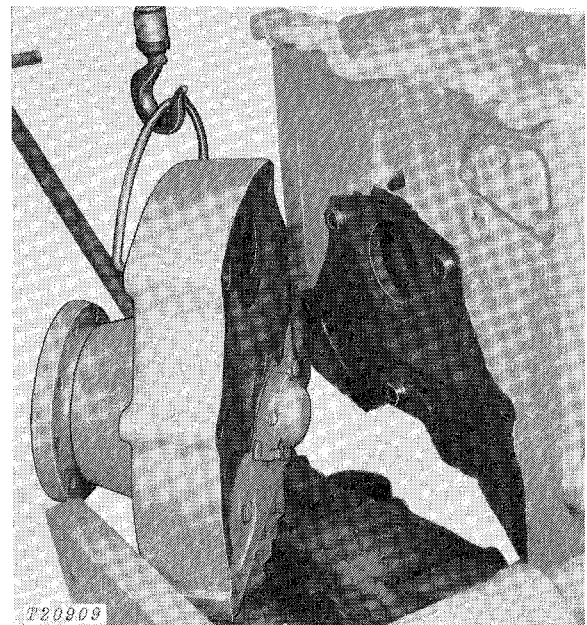

Fig. 7-Removing Final Drive

Under tractor, remove two inner cap screws attaching steering clutch housing to final drive.

Remove cap screws which hold final drive housing to steering clutch housing.

Using a hoist, lift final drive assembly away from steering clutch housing. The special yoke shown in Fig. 7 can be constructed from 1/2-inch round stock and will facilitate removal of the final drive assembly.

### Installation

Before installing final drive housing on tractor, install final drive pinion shaft in housing and determine the number of shims necessary behind quill to obtain

0.0000 to 0.0030 inch preload. (See page 60-20-4 for details). Then remove final drive pinion shaft and proceed with installation by reversing removal procedure.

Fill bearing bore in end of final drive pinion shaft half full of high temperature grease and coat pinion and bearing surfaces with oil. Carefully insert pinion shaft through final drive housing and pinion shaft oil seal, and on into steering clutch splines. DO NOT FORCE THE PINION SHAFT into position as forcing the shaft will misalign the bearings and damage the oil seal and inner splines on the steering clutch.

## REMOVING AND INSTALLING STEERING CLUTCHES

*NOTE: Alternate method of removing steering clutch assembly without removing final drive housing is to disconnect track assembly, remove track drive sprocket, back off final drive pinion shaft set screw, and remove bearing quill and final drive pinion shaft. Steering clutch drive shaft may then be reached through final drive housing. Refer to Fig. 9 and 10 for guide to steering clutch linkage.*

Disconnect all the necessary wiring, linkage and lines from rear tank unit (hydraulic reservoir, battery box and fuel tank). Remove cap screws securing rear tank unit support to steering clutch housing and lift rear tank unit from machine.

Remove final drive housing from steering clutch housing as instructed on page 10-25-3.

Remove steering clutch housing covers (Fig. 8). Reach through adjusting cover to unhook spring from eye screw.

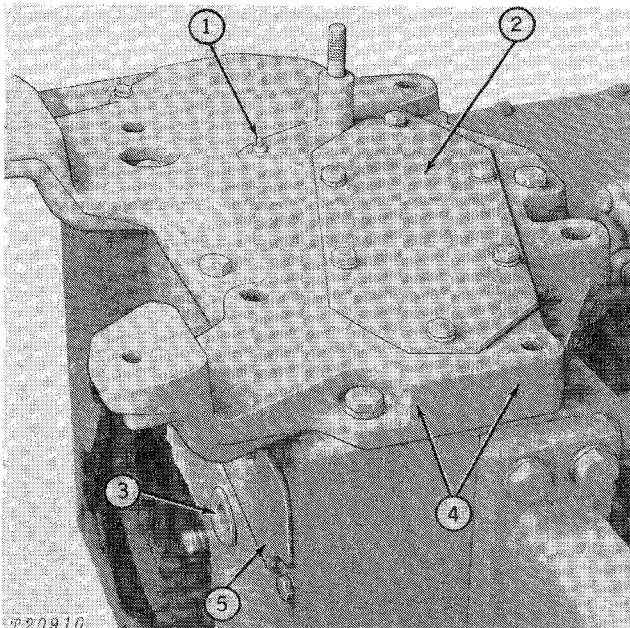

- 1—Spring Eye Screw
- 2—Adjusting Cover
- 3—Brake Yoke Plug
- 4—Steering Clutch Cover
- 5—Brake Adjusting Screw Cover

Fig. 8—Steering Clutch Housing Covers

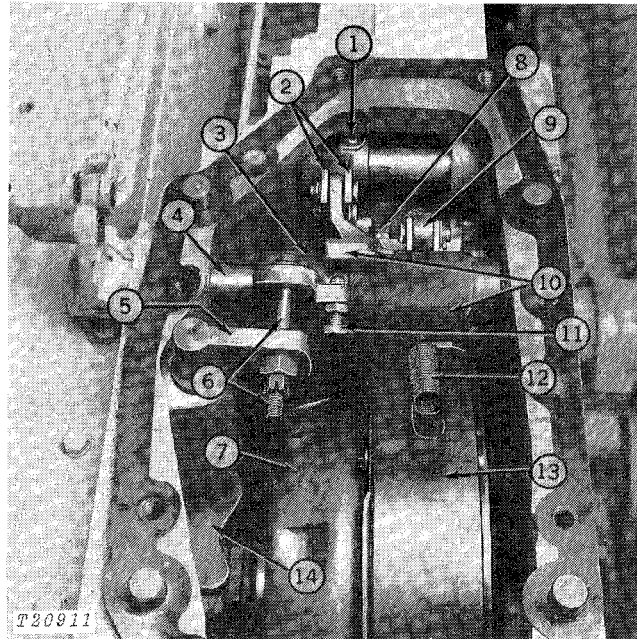

- 1—Foot Brake
- 2—Slotted Links
- 3—Steering Arm
- 4—Steering Shaft
- 5—Throw-Out Shaft
- 6—Clutch Rod
- 7—Clutch Assembly
- 8—Brake Anchor
- 9—Brake Band Yoke
- 10—Brake Bell Housing
- 11—Brake Actuator Screw
- 12—Upper Spring
- 13—Brake Band
- 14—Throw-Out Bearing Fork

Fig. 9—Steering Clutch and Brake Controls

Refer to Figs. 9 and 10 for removal of the following parts.

1. Reach through brake adjusting screw cover hole and loosen brake band adjusting screw. Unscrew jam nut and adjusting nut and remove clutch operating rod.

2. Remove return spring between foot brake lever and brake bell crank link. Remove cotter pins and

5. Holding steering arm against inside wall of steering clutch housing, use a brass drift and drive steering control shaft toward outside of tractor until Woodruff key can be removed from control shaft between steering arm and brake bell crank. Then drive out control shaft and remove steering arm and brake bell crank from steering clutch housing.

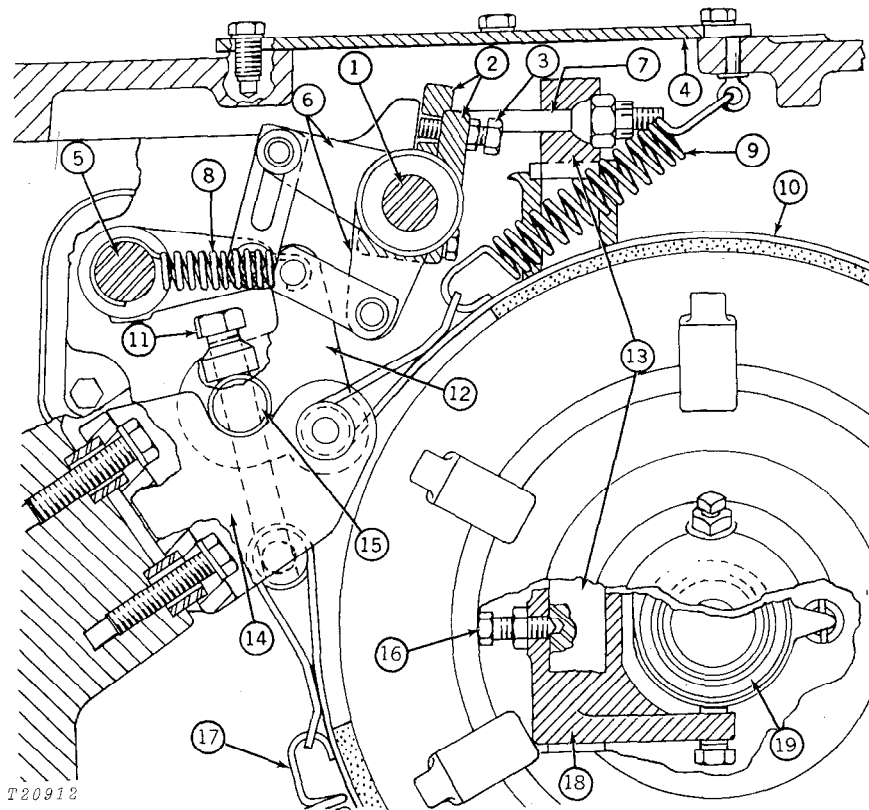

- |                            |                            |                             |
|----------------------------|----------------------------|-----------------------------|
| 1—Steering Shaft           | 7—Clutch Operating Rod     | 13—Throw-Out Shaft          |
| 2—Steering Arm             | 8—Linkage Return Spring    | 14—Brake Anchor             |
| 3—Brake Actuator Screw     | 9—Brake Band Return Spring | 15—Yoke Pin                 |
| 4—Adjusting Cover          | 10—Brake Band              | 16—Set Screw                |
| 5—Foot Brake Linkage Shaft | 11—Brake Adjusting Screw   | 17—Brake Band Return Spring |
| 6—Brake Bell Crank         | 12—Brake Band Yoke         | 18—Throw-Out Bearing Fork   |
|                            |                            | 19—Throw-Out Bearing        |

Fig. 10-Steering Clutch and Brake Controls

pins and disconnect links from their respective controls.

3. Remove steering arm lock screw.

4. Using a brass drift, drive steering arm toward center of tractor until arm contacts inside wall of steering clutch housing.

6. Remove brake band adjusting screw. Remove brake band yoke pin through plug hole in steering clutch housing. Lift out brake band yoke. Reach down to bottom of clutch housing and unhook lower brake band spring.

7. Loosen jam nut and set screw securing throw-out shaft to throw-out bearing fork. Rotate throw-out shaft until steering clutch assembly can be lifted out.

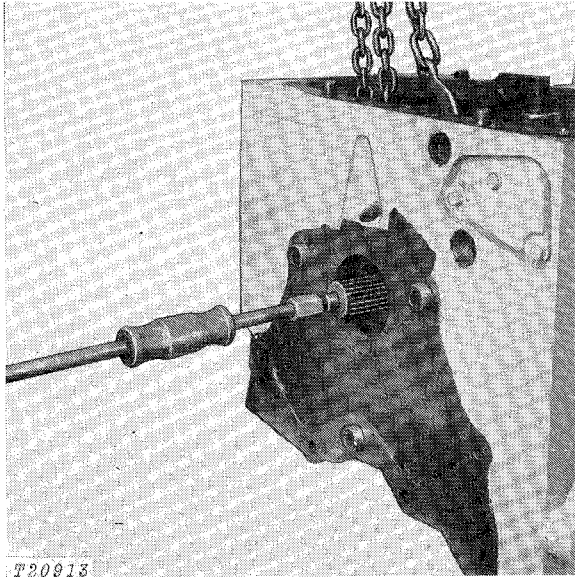

Fig. 11-Removing Steering Clutch Drive Shaft

Support steering clutch assembly. This can be done by rotating brake band around steering clutch drum and securing a chain to brake band ends as shown in Fig. 12.

Install suitable puller in threaded center hole of steering clutch drive shaft and carefully remove shaft (Fig. 11).

Place small chain through holes in band and using a chain hoist, lift out steering clutch assembly (Fig. 12).

Disconnect spring holding clutch throw-out bearing to differential quill.

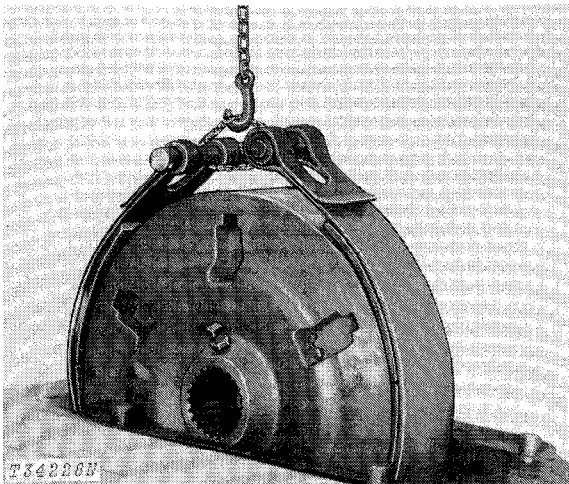

Fig. 12-Removing Steering Clutch Assembly

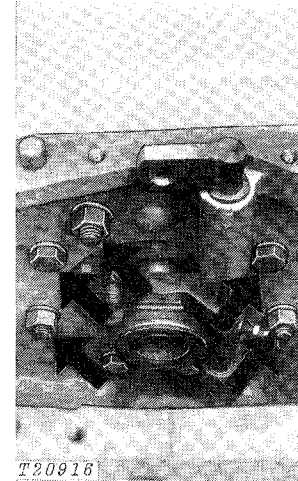
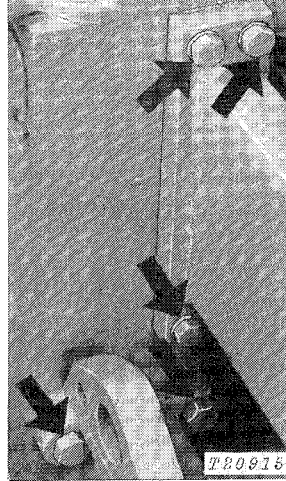

Fig. 13-Attaching Points

Remove cap screws securing steering clutch housing (Fig. 13) and with the aid of a hoist remove housing from transmission case.

### Installation

Install steering clutch housing by reversing removal procedure and noting the following:

**IMPORTANT: Tighten side frame-to-steering clutch cap screws before tightening side frame-to-engine clutch housing cap screws.**

Before installing steering clutch housing, apply non-hardening elastic sealing compound to mounting surfaces on both sides of the housing.

Position dowel cap screws in rear axle brackets in outside lower and inside upper holes.

Adjust steering clutch, steering brake and foot brake as instructed (page 60-25-6).

Install final drives (if removed) as instructed on page 10-25-3.

Tighten all cap screws to specifications (page 10-25-10).

## REMOVING AND INSTALLING TRANSMISSION

### Removal

#### Servicing Transmission Range and Speed Change Compartments Only

To gain access to the gears and shafts in the range change and speed change compartments (except for the pinion shaft assembly) the following tractor components must be removed:

1. Remove engine from clutch housing as instructed on page 10-25-1.
2. Remove engine clutch housing from transmission as instructed on page 10-25-2.

Proceed with service of range change and speed change assemblies in front two compartments of transmission case. See Section 50, Group 15.

#### Servicing Transmission Ring Gear and Pinion

With engine and clutch housing removed, the transmission ring gear and pinion shaft assembly is accessible only when the following tractor components are removed:

1. Disconnect track assembly as instructed on page 10-25-3.
2. Remove track drive sprocket, back off final drive pinion set screw, and remove bearing quill and final drive pinion shaft.
3. Remove steering clutch and brake assembly from steering clutch housing as instructed on page 10-25-4.

*NOTE: On crawler-loader tractors, loader does not have to be removed.*

4. Remove throw-out bearing and throw-out bearing carrier.
5. Carefully remove both ring gear bearing quills and shims and remove ring gears from transmission case.

### Replacing Transmission Case

If transmission case must be replaced, perform all of the preceding steps and continue as follows:

6. Remove final drive housing from steering clutch housing as instructed on page 10-25-3.
7. Using a chain hoist, support transmission case.
8. Remove steering clutch housing from transmission case as instructed on page 10-25-3.
9. Remove transmission case using chain hoist.

### Installation

Install transmission by reversing removal procedure.

**IMPORTANT: Tighten side frame-to-steering clutch cap screws before tightening side frame-to-engine clutch housing cap screws.**

Tighten all cap screws to specifications (page 10-25-10).

## REMOVING AND INSTALLING LOADER

### Removal

Drain oil from loader reservoir and disconnect loader hydraulic lines from rear tank unit.

Disconnect all the necessary wiring, linkage and lines between engine and cowl.

Remove air cleaner support and position chains around upper portion of loader frame. Attach chains to hoist.

Position floor jack or dolly with wheels under loader bucket to aid in removal.

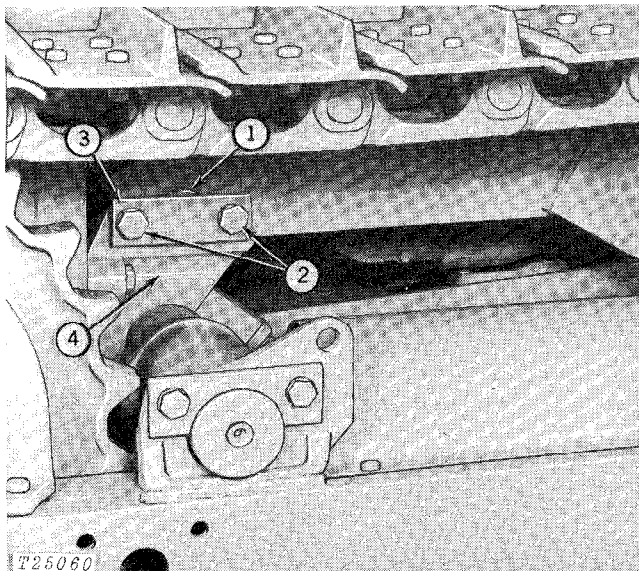

1—Mounting Frame Dowel  
2—Retaining Cap Screws  
3—Outside Retainer  
4—Rear Crossbar Bracket

Fig. 14-Loader Rear Mounting Points

Remove cap screws on both sides of loader securing outside dowel retainer to dowel retainer on inside of loader frame (Fig. 14).

Remove dowels securing loader frame to tractor right and left rear crossbar brackets.

Remove cap screws on both sides of loader securing front mounting pin to loader frame (Fig. 15).

Remove pins securing loader frame to front crossbar.

With the aid of a hoist, raise the loader high enough to clear the tractor and remove the loader.

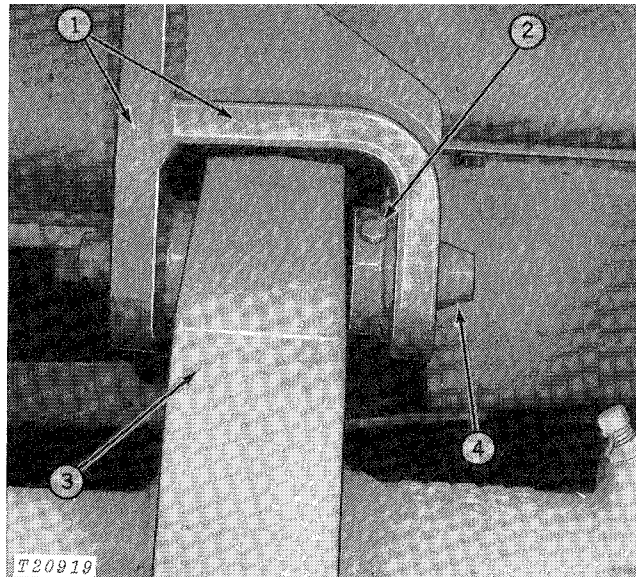

1—Loader Frame  
2—Cap Screw  
3—Front Crossbar  
4—Mounting Pin

Fig. 15-Loader Front Mounting Points

### Installation

Install loader by reversing removal procedure.

### SUPPORTING LOADER BOOM

It is desirable, in servicing some of the crawler loader components, to raise the boom to its full height. **CAUTION: Be absolutely certain the boom is then supported before working underneath it. This can be accomplished by three different methods, as follows:**

1. Cut a piece of angle iron (4 x 4 inch stock or larger) to a length of 24 inches. Attach it to the boom cylinder piston rod between the rod end and the cylinder barrel, being careful to avoid damaging the piston rod. Be sure the angle iron is large enough to rest against the cylinder barrel and not against the head casting.

*NOTE: A boom safety lock bar is available for supporting loader boom. See Page 10-25-11 for component parts.*

2. Use prop under cross member to support boom.
3. Chain bucket to hoist or overhead beam.

## REMOVING AND INSTALLING 9250 BACKHOES

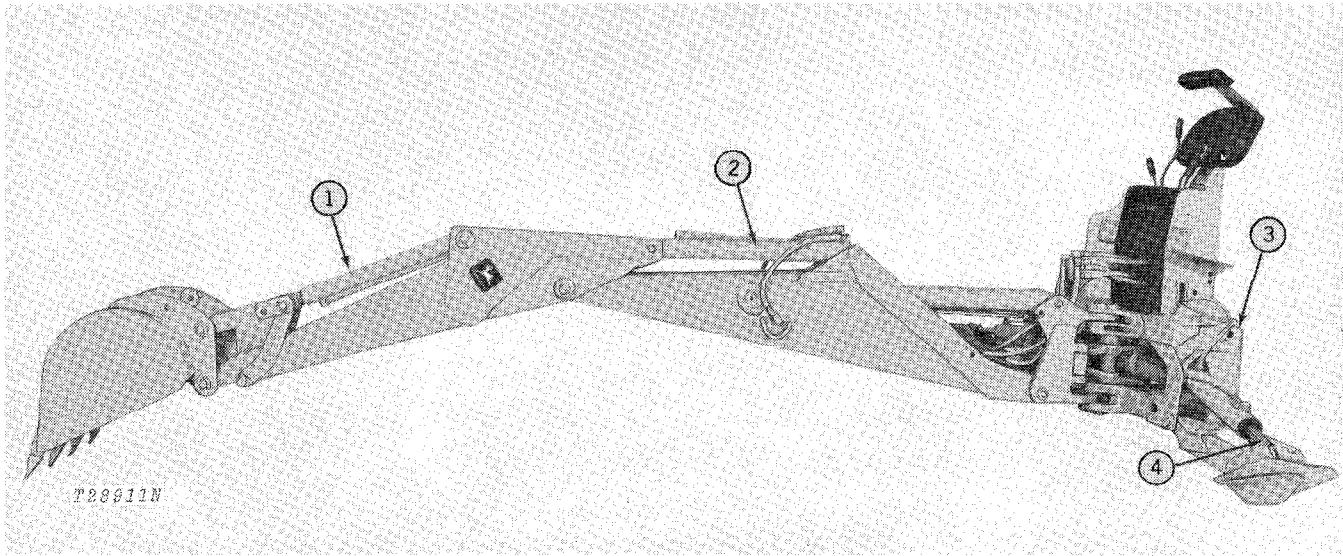

1—Bucket Cylinder (Retracted)  
2—Crowd Cylinder (Retracted)

3—Main Frame (Tipped Slightly Forward)  
4—Stabilizer Cylinders (Extended)

Fig. 16-Backhoe in Separation Position

### Removal

By using the backhoe hydraulic system, the backhoe can be easily detached to free the crawler for other jobs.

Lower the stabilizers until they are supporting the weight of the backhoe. Retract the bucket and dipperstick and extend boom cylinder until backhoe is fully extended and bucket is resting on the ground. Install swing locking pin in place to prevent tipping.

Remove the cotter pins and mounting pins which hold the top of the backhoe main frame to the crawler frame.

Use stabilizers to raise backhoe frame off the bottom mounting bracket hooks.

Carefully retract the stabilizers until the main frame is resting on the ground tilted slightly forward (Fig. 16).

*NOTE: The main frame can be blocked up off the ground by blocking across full width of backhoe main frame.*



**CAUTION:** Shut off the crawler engine before disconnecting the hydraulic lines to the backhoe. If the engine is left running the operator may be sprayed with hot hydraulic oil.

Disconnect the pressure and return hoses from the backhoe main frame at the quick disconnect couplers and connect hoses together.

**IMPORTANT:** Pressure and return hoses must be connected together at all times when backhoe is removed. DO NOT close the power beyond port in the loader valve or the pressure hose to the backhoe valve.

Wire the hoses to the crawler so they do not drag on the ground during crawler operations.

Carefully drive the crawler from the backhoe.

### Installation

Attach the pressure and return hoses to the backhoe main frame at the quick disconnect couplers.

Carefully raise the backhoe main frame with the hydraulic system by extending the stabilizers.

Carefully back the crawler to align the mounting bracket hooks with the lower pins on the backhoe main frame. Retract the stabilizers until the bottom pins rest in the mounting bracket hooks on the crawler.



Secure the top of each side of main frame to crawler with mounting pins and cotter pins.

# SPECIFICATIONS

## TORQUE VALUES

Item	Torque (ft-lbs)
Loader rear mounting frame dowel retainer	300
Rear crossbar cap to rear bar bracket	250
Rear crossbar bracket to steering clutch housing	300
Front crossbar to track frame (vertical)	240
(horizontal)	425
Front crossbar to side frame (vertical)	425
(horizontal)	240
Side frame to clutch housing	445
Side frame to steering clutch housing	170
Side frame to grille housing	170
Front bottom guard	85
Rear bottom guard	170
Final drive housing to steering clutch housing (5/8 inch)	170
(1/2 inch)	85
Drawbar support	300
Cowl support to clutch housing	85
Drive sprocket to axle shaft	300
Transmission case to clutch housing	300
Flywheel housing to clutch housing (upper)	250
(lower)	170
Bottom guard counterweight to steering clutch housing (F strength with Loctite)	425

## TORQUE CHART

RECOMMENDED TORQUE IN FT-LBS COARSE AND FINE THREADS			
	B	D	F
			
Bolt Diameter	Plain Head	Three Dashes	Six Dashes
1/4	Not used	10	14
5/16	Not used	20	30
3/8	Not used	35	50
7/16	35	55	80
1/2	55	85	120
9/16	75	130	175
5/8	105	170	240
3/4	185	300	425
7/8	160	445	685
1	250	670	1030
1-1/8	330	910	1460
1-1/4	480	1250	2060

The types of bolts and cap screws are identified by head markings as follows:

**Plain Head:** (B-strength) regular machine bolts and cap screws.

**3-Dash Head:** (D-strength) tempered steel high-strength bolts and cap screws.

**6-Dash Head:** (F-strength) tempered steel extra high-strength bolts and cap screws.

Machine bolts and cap screws 7/8 inch and larger are sometimes formed hot rather than cold, which accounts for the lower torque.