

4040 & 4240 Tractors

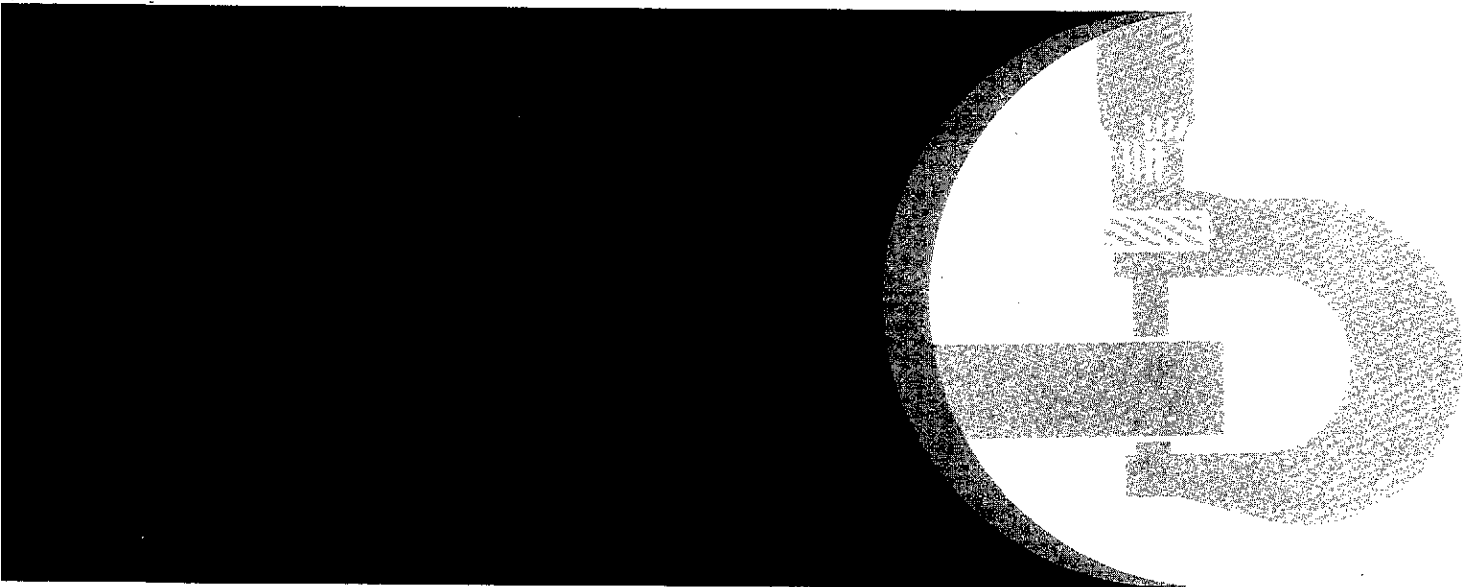

4040 AND 4240 TRACTORS TECHNICAL MANUAL TM-1181 (SEP-77)

CONTENTS—REPAIR SECTIONS

SECTION 10—GENERAL

- Group 00—Specifications and Special Tools
- Group 05—Predelivery, Delivery, and After-Sale Services
- Group 10—Tune-Up
- Group 15—Lubrication
- Group 20—Separation

SECTION 20—ENGINE REPAIR

- Group 00—Specifications and Special Tools
- Group 05—Cylinder Head, Valves, and Camshaft
- Group 10—Cylinder Block, Liners, Pistons, and Rods
- Group 15—Crankshaft, Main Bearings, and Flywheel
- Group 20—Lubricating System
- Group 25—Cooling System

SECTION 30—FUEL AND AIR REPAIR

- Group 00—Specifications and Special Tools
- Group 05—Air Intake System
- Group 10—Diesel Fuel System
- Group 15—Control Linkage

SECTION 40—ELECTRICAL REPAIR

- Group 00—Specifications and Special Tools
- Group 05—Harness Replacement
- Group 10—Charging Circuit
- Group 15—Starting Circuit
- Group 20—Lighting Circuits
- Group 25—Instrument and Accessory Circuits
- Group 30—Power Front-Wheel Drive

SECTION 50—POWER TRAIN REPAIR

- Group 00—Specifications and Special Tools
- Group 05—Perma-Clutch™
- Group 10—Syncro Range Transmission (Also 8-Speed Portion of Quad-Range and Creeper)

SECTION 50—POWER TRAIN REPAIR (Continued)

- Group 15—Creeper Planetary
- Group 20—Quad-Range Planetary and Shifter Assembly
- Group 25—Power Shift Transmission
- Group 30—Dual-Speed PTO
- Group 35—Differential
- Group 40—Final Drive
- Group 45—Power Front-Wheel Drive

SECTION 60—STEERING/BRAKES REPAIR

- Group 00—Specifications and Special Tools
- Group 05—Power Steering
- Group 10—Power Brakes

SECTION 70—HYDRAULIC REPAIR

- Group 00—Specifications and Special Tools
- Group 05—Miscellaneous Hydraulic Components
- Group 10—Hydraulic Pumps
- Group 15—Rockshaft and Implement Hitches
- Group 20—Selective Control Valve and Remote Cylinder

SECTION 80—MISCELLANEOUS

- Group 00—Specifications and Special Tools
- Group 05—Front Axles
- Group 10—Wheels

SECTION 90—OPERATOR STATION REPAIR

- Group 00—Specifications and Special Tools
- Group 05—Air Conditioning System
- Group 10—Heating System
- Group 15—Seat
- Group 20—Miscellaneous Components
(Continued on page 2)

All information, illustrations and specifications contained in this technical manual are based on the latest information available at the time of publication. The right is reserved to make changes at any time without notice.

CONTENTS—OPERATION AND TESTS SECTIONS**SECTION 220—ENGINE OPERATION AND TESTS**

- Group 00—Specifications and Special Tools
- Group 05—System Operation
- Group 10—System Tests and Diagnosis

SECTION 230—FUEL/AIR OPERATION AND TESTS

- Group 00—Specifications and Special Tools
- Group 05—Air Intake System
- Group 10—Diesel Fuel System
- Group 15—Control Linkage

SECTION 240—ELECTRICAL OPERATION AND TESTS

- Group 00—Specifications and Special Tools
- Group 05—General Information and Diagrams
- Group 10—Charging Circuit
- Group 15—Starting Circuit
- Group 20—Lighting Circuits
- Group 25—Instrument and Accessory Circuits
- Group 30—Power Front-Wheel Drive
- Group 35—Electrical Remote Control and Outlet Socket

SECTION 250—POWER TRAIN OPERATION AND TESTS

- Group 00—Specifications and Special Tools
- Group 05—Perma-Clutch Systems Operation
- Group 10—Perma-Clutch Systems Tests
- Group 15—Power Shift Transmission Operation
- Group 20—Power Shift Transmission Tests
- Group 25—Differential and Final Drive
- Group 30—Power Front-Wheel Drive

SECTION 260—STEERING/BRAKES OPERATION AND TESTS

- Group 00—Specifications and Special Tools
- Group 05—Power Steering
- Group 10—Power Brakes

SECTION 270—HYDRAULIC OPERATION AND TESTS

- Group 00—Specifications and Special Tools
- Group 05—Hydraulic System Operation
- Group 10—Hydraulic System Tests
- Group 15—Miscellaneous Hydraulic Components
- Group 20—Hydraulic Pumps
- Group 25—Rockshaft and Implement Hitches
- Group 30—Selective Control Valve and Remote Cylinder

SECTION 290—OPERATOR STATION OPERATION AND TESTS

- Group 00—Specifications and Special Tools
- Group 05—Air Conditioning System
- Group 10—Heating System

Section 10 GENERAL

CONTENTS OF THIS SECTION

	Page		Page
GROUP 00—SPECIFICATIONS		GROUP 15—LUBRICATION	
General Tractor Specifications	10-00-1	Lubricants	10-15-1
Predelivery	10-00-4	Engine	10-15-2
Tune-Up	10-00-5	Transmission-Hydraulic System	10-15-3
Lubrication	10-00-5	Hi-Crop Final Drive Housings	10-15-5
Separation	10-00-6	Front Wheel Bearings	10-15-6
Special Tools	10-00-7	Grease Fittings	10-15-6
 GROUP 05—PREDELIVERY, DELIVERY, AND AFTER-SALE SERVICES		 GROUP 20—SEPARATION	
Dealer Predelivery Service	10-05-1	Removing SOUND-GARD® Body without Control Support	10-20-1
Inspection Checks	10-05-11	Removing SOUND-GARD Body with Control Support	10-20-5
Dealer Service	10-05-13	Separating Engine from Clutch Housing	10-20-10
After-Sale Inspection	10-05-14	Removing Front End	10-20-14
 GROUP 10—TUNE-UP		Removing Engine	10-20-18
Preliminary Engine Testing	10-10-1	Separating Clutch Housing from Power Shift Transmission Case	10-20-21
Engine Tune-Up	10-10-1	Separating Clutch Housing from QUAD-RANGE™ Transmission Case ..	10-20-24
Operation	10-10-7	Removing Rear Axle Housing	10-20-26
General	10-10-7		

Group 00 SPECIFICATIONS AND SPECIAL TOOLS GENERAL TRACTOR SPECIFICATIONS

	4040	4240
HORSEPOWER (Factory observed PTO horsepower at 2200 rpm)	90 hp (67 kW)	110 hp (82 kW)
ENGINE:		
Type	6-cylinder, in-line, valve-in-head, diesel	6-cylinder, in-line, valve-in-head, diesel
Slow idle speed	800 rpm	800 rpm
Working speed range	1500 to 2200 rpm	1500 to 2200 rpm
Bore and stroke	4.25 x 4.75 in. (108 x 121 mm)	4.56 x 4.75 in. (116 x 121 mm)
Displacement	404 cu. in. (6.6 L)	466 cu. in. (7.6 L)
Compression ratio	16.7 to 1	17.0 to 1
Firing order	1-5-3-6-2-4	1-5-3-6-2-4
Valve clearance		
Intake	0.018 in. (0.46 mm)	0.018 in. (0.46 mm)
Exhaust	0.028 in. (0.71 mm)	0.028 in. (0.71 mm)
Injection pump timing	TDC	TDC
Lubrication system	force-feed, pressurized with full-flow filter	force-feed, pressurized with full-flow filter

	4040	4240
FUEL SYSTEM		
Type	direct injection	direct injection
Injection pump type	distributor	distributor
Air cleaner	dry type with safety element	dry type with safety element
COOLING SYSTEM		
Type	dual-pressure with centrifugal pump	dual pressure with centrifugal pump
Temperature control	dual heavy duty thermostats	dual heavy duty thermostats
CAPACITIES		
Fuel tank	37 U.S. gal. (140 L)	46 U.S. gal. (176 L)
Cooling system	24 U.S. qts. (23 L)	30 U.S. qts. (28 L)
Crankcase (with filter change)	17 U.S. qts. (16 L)	17 U.S. qts. (16 L)
Transmission-hydraulic system (Drain and fill):		
Power Shift Transmission	11.0 U.S. gal. (41.6 L)	11.0 U.S. gal. (41.6 L)
QUAD-RANGE or Syncro-Range		
Transmission	13.0 U.S. gal. (49.2 L)	13.0 U.S. gal. (49.2 L)
Add for power front-wheel drive	4.0 U.S. gal. (15.1 L)	4.0 U.S. gal. (15.1 L)
Transmission-hydraulic system (Dry, production fill):		
Power Shift Transmission	15.9 U.S. gallons (60.3 L)	15.9 U.S. gallons (60.3 L)
QUAD-RANGE or Syncro-Range		
Transmission	15.9 U.S. gal. (60.3 L)	15.9 U.S. gal. (60.3 L)
Add for power front-wheel drive	5.0 U.S. gallons (18.9 L)	5.0 U.S. gal. (18.9 L)
POWER SHIFT TRANSMISSION:		
Type	planetary gears, hydraulically actuated wet disk clutches and brakes	planetary gears, hydraulically actuated wet disk clutches and brakes
Gear selections	8 forward and 4 reverse	8 forward and 4 reverse
Shifting	hydraulic, on-the-go and under load	hydraulic, on-the-go and under load
QUAD-RANGE TRANSMISSION		
Type	2-speed, power-shifted planetary and 8-speed synchronized 16 forward and 6 reverse	2-speed, power-shifted planetary and 8-speed synchronized 16 forward and 6 reverse
Gear selections	hydraulically-operated, multiple-disk wet clutch	hydraulically-operated, multiple-disk wet clutch
Perma-Clutch		
SYNCRO-RANGE TRANSMISSION		
Type	synchronized, constant mesh	synchronized, constant mesh
Gear selections	8 forward and 2 reverse	8 forward and 2 reverse
Shifting	4 stations; synchronized forward speed shifting within stations	4 stations; synchronized forward speed shifting within stations
CREEPER TRANSMISSION		
Type	8-speed Syncro-Range plus 2-speed collar-shifted planetary	8-speed Syncro-Range plus 2-speed collar-shifted planetary
Gear selections	13 forward and 4 reverse	13 forward and 4 reverse
Shifting	same as Syncro-Range plus collar shift between ranges	same as Syncro-Range plus collar shift between ranges
POWER TAKE-OFF:		
Type	fully independent, dual-speed	fully independent, dual-speed
Speeds (2200 engine rpm)	1000 rpm or independent 540 and 1000 rpm	1000 rpm or independent 540 and 1000 rpm
Size	1-3/8 in. (35 mm)	1-3/8 in. (35 mm)
Clutch	hydraulically-operated, multiple-disk wet clutch	hydraulically-operated, multiple-disk wet clutch
POWER FRONT-WHEEL DRIVE:		
Type	hydraulic motor with planetary gear reduction, constant torque and variable speed	hydraulic motor with planetary gear reduction, constant torque and variable speed
Controls	solenoid-operated valves, synchronized with transmission controls	solenoid-operated valves, synchronized with transmission controls

	4040	4240
HYDRAULIC SYSTEM:		
Type	closed-center, constant-pressure	closed-center, constant-pressure
Standby pressure	2250 psi (155 bar) (155 kg/cm ²)	2250 psi (155 bar) (155 kg/cm ²)
BRAKES:		
Type	hydraulically-operated wet disk	hydraulically-operated wet disk
ELECTRICAL SYSTEM:		
Type	12-volt, negative ground	12-volt, negative ground
Batteries	two, 6-volt, 5D group, 800 amps cold cranking, 376 minutes reserve capacity	two, 6-volt, 5D group, 800 amps cold cranking, 376 minutes reserve capacity
Alternator	72-amp with SOUND-GARD body, 61-amp without	72-amp with SOUND-GARD body, 61-amp without
TIRES AND THREADS:	see page 05-6 in this section	see page 05-6 in this section
DIMENSIONS:		
Wheelbase	104.0 in. (2 642 mm)	105.7 in. (2 709 mm)
Overall length	153.2 in. (3 892 mm)	156.6 in. (3 977 mm)
Height to muffler cover*		
Tractors with SOUND-GARD body	119.8 in. (3 040 mm)	123.0 in. (3 122 mm)
Tractors without SOUND-GARD body	111.8 in. (2 837 mm)	115.0 in. (2 918 mm)
Height to top of SOUND-GARD Body*	109.3 in. (2 775 mm)	114.1 in. (2 895 mm)
Overall width (regular axle)	90 in. (2 277 mm)	90 in. (2 277 mm)
Width at fender	82 in. (2 082 mm)	82 in. (2 082 mm)
Width at roof	54.4 in. (1 382 mm)	54.4 in. (1 382 mm)
Turning radius	134 in. (3 400 mm)	146 in. (3 700 mm)
SHIPPING WEIGHT**	9630 lbs. (4370 kg)	10,900 lbs. (4975 kg)

*4040 Tractor equipped with 18.4-34 rear tires and 9.5L-15 front tires. 4240 Tractor equipped with 18.4-38 rear tires and 10.00-16 front tires.

**Equipped for average field service, without fuel and ballast. Add approximately 1000 lbs. (450 kg) if equipped with power front-wheel drive. Subtract 900 lbs. (400 kg) if not equipped with SOUND-GARD Body.

GROUND SPEEDS

Speeds in the following charts are in miles per hour, with kilometers per hour in parenthesis. Speeds are for a 4040 Tractor with 18.4-34 tires or a 4240 Tractor with 18.4-38 tires.

POWER SHIFT TRANSMISSION

Gear	1500 rpm		2200 rpm	
	1500 rpm	2200 rpm	1500 rpm	2200 rpm
1	1.1 (1.8)	1.7 (2.7)	1.2 (1.9)	1.8 (2.9)
2	1.6 (2.6)	2.4 (3.9)	1.7 (2.7)	2.5 (4.0)
3	2.5 (4.0)	3.7 (6.0)	2.6 (4.2)	3.8 (6.2)
4	3.2 (5.2)	4.7 (7.6)	3.4 (4.9)	4.9 (7.9)
5	4.2 (6.8)	6.1 (9.8)	4.4 (7.1)	6.5 (10.5)
6	5.4 (8.7)	7.9 (12.7)	5.7 (9.2)	8.3 (13.4)
7	7.1 (11.4)	10.5 (16.9)	7.6 (12.2)	11.2 (18.0)
8	11.9 (19.2)	17.5 (28.2)	12.9 (20.7)	18.9 (30.4)
1R	1.3 (2.1)	1.9 (3.1)	1.5 (2.4)	2.2 (3.5)
2R	1.9 (3.1)	2.8 (4.5)	2.1 (3.4)	3.1 (5.0)
3R	2.9 (4.7)	4.3 (6.9)	3.2 (5.1)	4.7 (7.6)
4R	3.8 (6.1)	5.5 (8.9)	4.1 (6.6)	6.0 (9.7)

GROUND SPEEDS—Continued

QUAD-RANGE TRANSMISSION

Gear	4040		4240	
	1500 rpm	2200 rpm	1500 rpm	2200 rpm
A 1	1.3 (2.1)	1.9 (3.1)	1.4 (2.2)	2.0 (3.2)
2	1.6 (2.6)	2.4 (3.7)	1.8 (2.9)	2.6 (4.2)
3	2.1 (3.4)	3.1 (5.0)	2.3 (3.7)	3.4 (5.4)
4	2.7 (4.3)	4.0 (6.4)	2.9 (4.7)	4.3 (6.9)
1R	2.1 (3.4)	3.0 (4.8)	2.2 (3.5)	3.2 (5.2)
2R	2.6 (4.2)	3.9 (6.3)	2.8 (4.5)	4.1 (6.6)
B 1	3.0 (4.8)	4.4 (7.1)	3.2 (5.1)	4.7 (7.6)
2	3.8 (6.1)	5.6 (9.0)	4.0 (6.5)	5.9 (9.5)
3	4.9 (7.9)	7.2 (11.6)	5.3 (8.5)	7.7 (12.4)
4	6.3 (10.1)	9.2 (14.8)	6.7 (10.8)	9.8 (15.8)
1R	4.8 (7.7)	7.0 (11.3)	5.1 (8.2)	7.5 (11.9)
2R	6.1 (9.8)	8.9 (14.3)	6.5 (10.5)	9.5 (15.3)
C 1	3.5 (5.6)	5.2 (8.4)	3.8 (6.1)	5.5 (8.9)
2	4.5 (7.2)	6.6 (10.6)	4.8 (7.7)	7.0 (11.3)
3	5.8 (9.3)	8.6 (13.8)	6.2 (10.0)	9.2 (14.7)
4	7.4 (11.9)	10.9 (17.5)	7.9 (12.7)	11.6 (18.6)
1R	5.6 (9.0)	8.3 (13.4)	6.0 (9.7)	8.9 (14.2)
2R	7.2 (11.6)	10.5 (16.9)	7.7 (12.4)	11.2 (18.0)
D 1	5.4 (8.7)	8.0 (12.9)	5.8 (9.3)	8.5 (13.7)
2	6.9 (11.1)	10.1 (16.3)	7.3 (11.7)	10.8 (17.4)
3	9.0 (14.4)	13.2 (21.2)	9.6 (15.4)	14.0 (22.6)
4	11.4 (18.3)	16.7 (26.9)	12.2 (19.6)	17.8 (28.7)

SYNCRO-RANGE TRANSMISSION

1	1.3 (2.1)	1.9 (3.1)	1.4 (2.2)	2.0 (3.2)
2	2.1 (3.4)	3.0 (4.8)	2.2 (3.5)	3.2 (5.2)
3	2.7 (4.3)	4.0 (6.4)	2.9 (4.7)	4.2 (6.8)
4	3.5 (5.6)	5.1 (8.2)	3.7 (6.0)	5.4 (8.7)
5	4.3 (7.0)	6.3 (10.2)	4.6 (7.4)	6.8 (10.9)
6	5.7 (9.1)	8.3 (13.4)	6.1 (9.8)	8.9 (14.3)
7	7.3 (11.8)	10.7 (17.3)	7.8 (12.5)	11.5 (18.5)
8	11.9 (19.2)	17.5 (28.2)	12.8 (20.6)	18.8 (30.3)
1R	2.6 (4.2)	3.8 (6.3)	2.8 (4.5)	4.1 (6.6)
2R	4.2 (6.8)	6.2 (10.0)	4.5 (7.2)	6.6 (10.6)
With optional Creeper engaged				
1	0.3 (0.5)	0.4 (0.7)	0.3 (0.4)	0.4 (0.6)
2	0.4 (0.7)	0.6 (1.0)	0.4 (0.7)	0.6 (1.0)
3	0.5 (0.9)	0.8 (1.3)	0.5 (1.0)	0.8 (1.4)
4	0.8 (1.2)	1.1 (1.8)	0.8 (1.2)	1.1 (1.8)
5	0.9 (1.4)	1.3 (2.1)	1.0 (1.6)	1.3 (2.2)
1R	0.5 (0.9)	0.8 (1.3)	0.5 (0.8)	0.8 (1.2)
2R	0.9 (1.4)	1.3 (2.1)	0.9 (1.5)	1.3 (2.2)

(Specifications and design subject to change without notice.)

PREDELIVERY, DELIVERY, AND AFTER-SALE SERVICES

Item	Specification
Toe-in	1/8 to 3/8 inch (3 to 9 mm)
Injection pump timing	TDC
Engine speeds	
Slow idle	780 to 820 rpm
Fast idle	2325 to 2425 rpm
Rated speed at full load	2200 rpm

Torque	ft-lbs	Nm	kgm
SOUND-GARD Body or Four-Post ROLL-GARD® mounting bolts	150	200	20
Front axle-to-knee bolts:			
Narrow front axle	320	435	44
Regular or wide front axle	370	500	50
Hi-Crop	445	600	60
Front wheel-to-hub bolts	100	135	14
Special bolts on rear hubs	300	410	41
Steel wheel-to-hub bolts	240	325	33
Rim clamp-to-wheel bolts	170	230	23
Rockshaft lift arm retaining bolts	300	410	41
Other nuts and cap screws:			

Bolt Diameter	Plain Head*			Three Radial Dashes*			Six Radial Dashes*		
	ft-lbs	Nm	kgm	ft-lbs	Nm	kgm	ft-lbs	Nm	kgm
1/4 in. (6.35 mm)	6	8	0.8	10	14	1.4	14	19	1.9
5/16 in. (7.93 mm)	13	18	1.8	20	27	2.7	30	41	4.1
3/8 in. (9.53 mm)	23	31	3.1	35	47	4.7	50	70	7.0
7/16 in. (11.11 mm)	35	47	4.7	55	75	7.5	80	110	11
1/2 in. (12.70 mm)	55	75	7.5	85	115	12	120	160	16
9/16 in. (14.29 mm)	75	100	10	130	175	18	175	240	24
5/8 in. (15.88 mm)	105	140	14	170	230	23	240	325	33
3/4 in. (19.05 mm)	185	250	25	300	410	41	425	575	58
7/8 in. (22.23 mm)	160	220	22**	445	600	60	685	930	93
1 in. (25.40 mm)	250	340	34**	670	900	90	1030	1400	140

*The types of bolts and cap screws are identified by head markings as follows:

Plain Head: regular machine bolts and cap screws.

3-Dash Head: tempered steel high-strength bolts and cap screws.

6-Dash Head: tempered steel extra high-strength bolts and cap screws.

**Machine bolts and cap screws 7/8-inch and larger are sometimes formed hot rather than cold, which accounts for the lower torque.

TUNE-UP

Item	Specification
PTO horsepower	
4040	90 hp (67 kW)
4240	110 hp (82 kW)
Compression	370 to 400 psi (25.5 to 27.6 bar)
Air cleaner indicator switch closing vacuum	24 to 26 in. (60 to 65 mbar)
Thermostat opening temperature	160 to 180°F (71 to 82°C)
Radiator cap pressure release	
Low pressure cap	6.25 to 7.50 psi (0.4 to 0.5 bar)
High pressure cap	14 to 17 psi (0.9 to 1.2 bar)
Engine speeds	
Slow idle	780 to 820 rpm
Fast idle	2325 to 2425 rpm
Rated speed at full load	2200 rpm

LUBRICATION

Engine crankcase oil capacity	17 U.S. quarts (16 L)
Transmission-hydraulic system	
(Drain and fill):	
Power Shift Transmission	11.0 U.S. gal. (41.6 L)
QUAD-RANGE or Syncro-Range Transmission	13.0 U.S. gal. (49.2 L)
Add for power front-wheel drive	4.0 U.S. gal. (15.1 L)
Transmission-hydraulic system	
(Dry, production fill):	
Power Shift Transmission	15.9 U.S. gal. (60.3 L)
QUAD-RANGE or Syncro-Range Transmission	15.9 U.S. gal. (60.3 L)
Add for power front-wheel drive	5.0 U.S. gal. (18.9 L)
Service intervals	
Check engine oil level	Every 10 hours
Change engine oil	Every 100 hours
Replace engine oil filter	Every 200 hours
Clean crankcase breather filter	Every 200 hours
Check transmission-hydraulic system oil level	Every 200 hours
Replace transmission-hydraulic system oil filter (Quad-Range)	Every 200 hours
Replace transmission-hydraulic system oil filters (Power Shift)	Every 600 hours
Change transmission-hydraulic oil	Every 1200 hours
Clean main hydraulic pump screen	Every 1200 hours
Clean and repack front wheel bearings	Every 1200 hours
Lubricate grease fittings	
Front axle pivot pins, steering spindles, tie rods (10 fittings)	Every 10 hours
Wide-swing drawbar rollers (if equipped)	Every 10 hours
Front wheel bearings (only in extremely wet conditions)	Every 10 hours
3-point hitch	Every 200 hours
Load control shaft bushings	Every 200 hours
Rear axle bearings	Every 600 hours
Vacuum (full speed, full load, clean air filters)	
4040	7.5 to 8.5 in. (19 to 21 mbar)
4240	9 to 10 in. (22 to 25 mbar)

SEPARATION

ITEM	SPECIFICATION
Fan belt tension	New Belt
Single belt	130-140 lbs. (578-622 N)
Dual belt	95-104 lbs. (423-467 N)
	After Run In
All belts	85-94 lbs. (378-423 N)
ITEM	TORQUE
Sound-Gard Body retaining cap screws	150 ft-lbs (203 Nm) (20.3 kgm)
Roll-Gard® (4-post) mounting cap screws	150 ft-lbs (203 Nm) (20.3 kgm)
Engine-to-clutch housing cap screws	1/2 in.—85 ft-lbs (115 Nm) (11.5 kgm)
	3/4 in.—300 ft-lbs (406 Nm) (40.6 kgm)
Clutch housing-to-engine cap screws	300 ft-lbs (406 Nm) (40.6 kgm)
Hydraulic pump support-to-engine cap screws	85 ft-lbs (115 Nm) (11.5 kgm)
Hydraulic pump coupler lock nuts	30 ft-lbs (41 Nm) (4.1 kgm)
Hydraulic pump drive coupling	35 ft-lbs (47 Nm) (4.7 kgm)
Side frames-to-engine	5/8 in.—275 ft-lbs (373 Nm) (37.3 kgm)
	3/4 in.—425 ft-lbs (578 Nm) (57.8 kgm)
Clutch housing-to-transmission case cap screws	5/8 in.—170 ft-lbs (230 Nm) (23 kgm)
	3/4 in.—300 ft-lbs (406 Nm) (40.6 kgm)
Oil filter inlet pipe elbow cap screws	45 ft-lbs (61 Nm) (6.1 kgm)
Axle housing-to-transmission case cap screws	170 ft-lbs (230 Nm) (23 kgm)
Hi-Crop drive shaft housing-to-final drive gear housing	275 ft-lbs (373 Nm) (37.3 kgm)
Radiator hose clamps (clean and dry)	36 in-lbs (4 Nm) (0.4 kgm)
Transmission pump elbow-to-clutch housing cap screws	45 ft-lbs (61 Nm) (6.1 kgm)
Oil pan-to-clutch housing cap screws	85 ft-lbs (115 Nm) (11.5 kgm)
Hose clamps	30 in-lbs (3.4 Nm) (0.3 kgm)

SPECIAL TOOLS

Predelivery, Delivery, and After-Sale Services

TOOL

USE

JDG-18 Snap Ring Tool

Remove and install snap rings on ends of rear axles

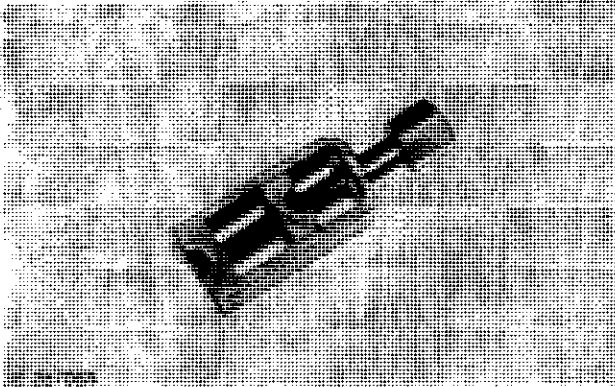
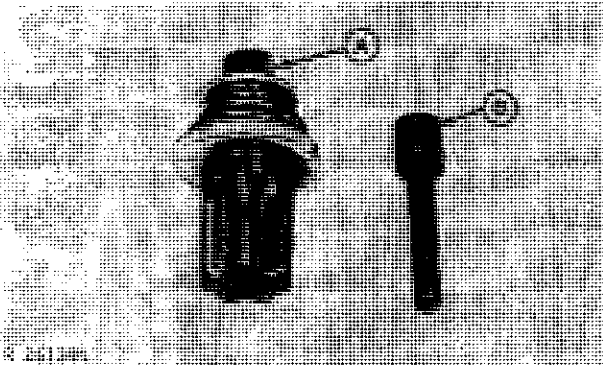

Fig. 1—JDG-18 Snap Ring Tool*

JDE-81-1 Engine Rotation Tool and JDE-81-4 Timing Pin

Turn engine to TDC to check injection pump timing



A—JDE-81-1 Engine Rotation Tool*
B—JDE-81-4 Timing Pin*

Fig. 2—Tools Required for Checking Timing

JDE-28 Adapter and Hand Tachometer

Check engine speeds

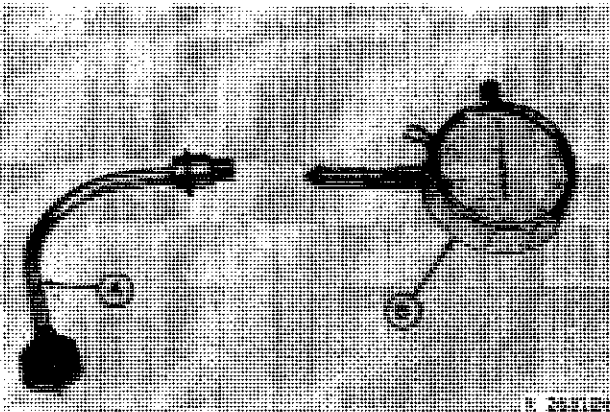

A—JDE-28 Adapter* B—Hand Tachometer

Fig. 3—Tools Required for Checking Engine Speeds

Tune-Up

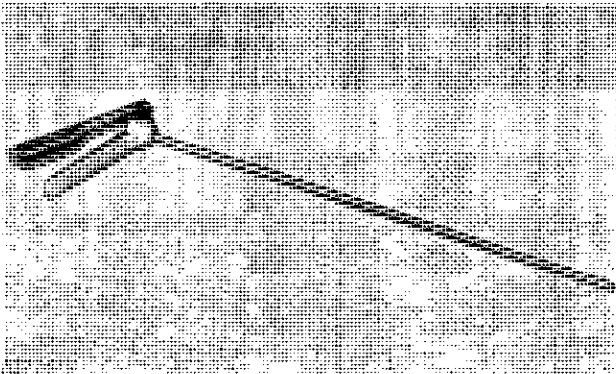

Fig. 4-AR62377 Dry Element Cleaning Gun

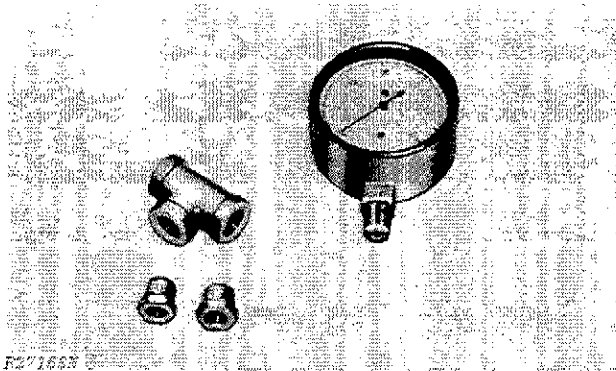

Fig. 5-D-05022ST Water Vacuum Gauge*
(Formerly JDST-11)

TOOL

USE

JDE-81-1 Engine Rotation Tool and JDE-81-4 Timing Pin

Turn engine to TDC to check injection pump timing

JDE-28 Adapter and Hand Tachometer

Check engine speeds

AR62377 Dry Element Cleaning Gun

Clean primary element of air cleaner

D-05022ST Water Vacuum Gauge

Measure air intake vacuum

TOOL

NUMBER

USE

BT-11-52 Radiator Tester

Pressure test cooling system and radiator caps

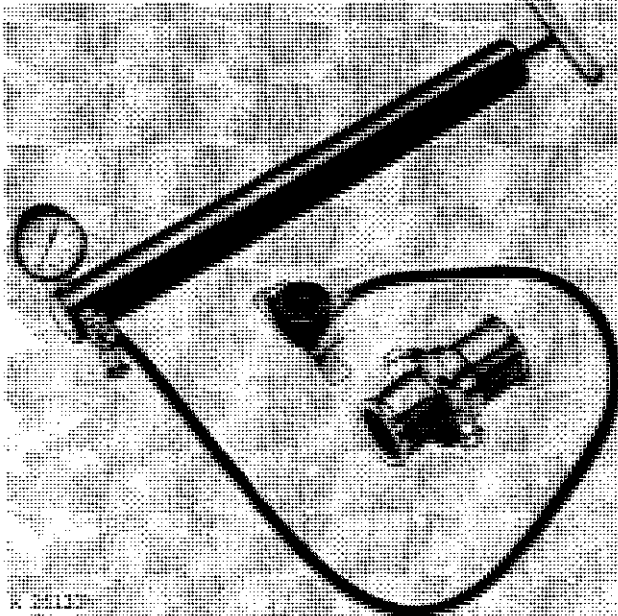

Fig. 6-BT-11-52 Radiator Tester*

Separation

Brown Body Lift

To remove Sound-Gard Body.

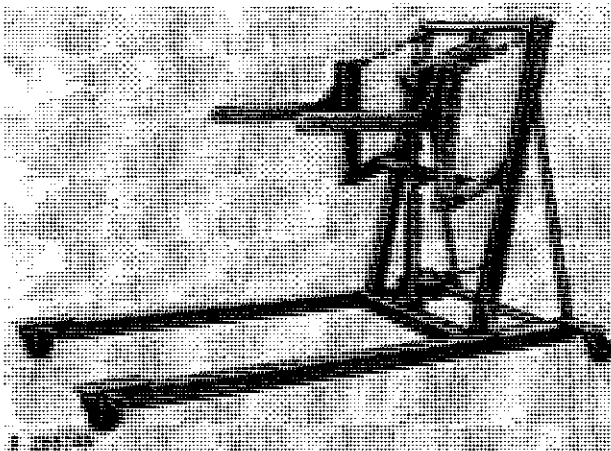

Fig. 7-Brown Body Lift

JDG-21 Fork Lift Adapters

To remove Sound-Gard Body

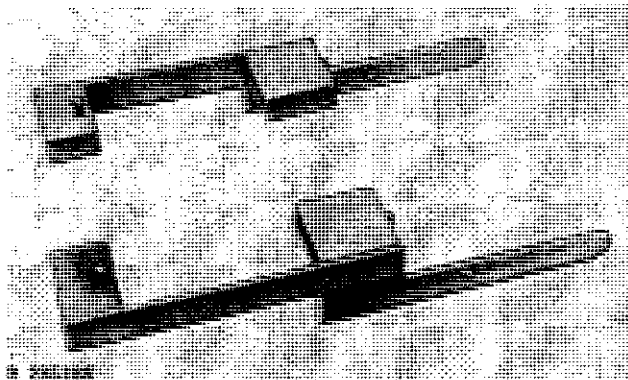

Fig. 8-Fork Lift Adapters

Separation—Continued

TOOL

NUMBER

USE

JDG-10-2

To support Sound-Gard Body after removal.

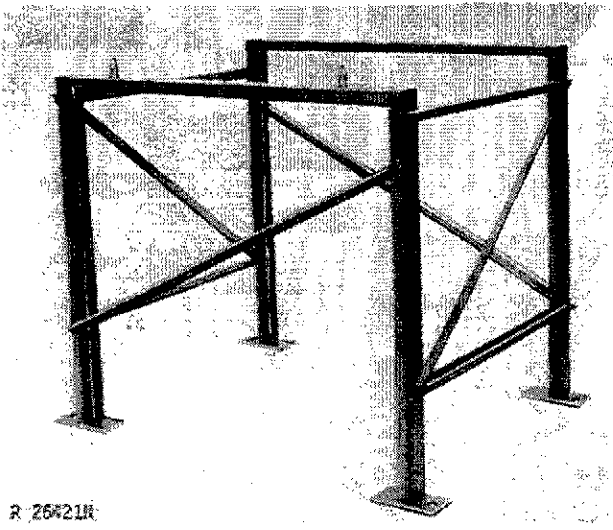

R 26421R

Fig. 9-Sound-Gard Body Stand*

A-D-05007ST
Splitting Stand

To support tractor in various separations.

B-D-05149ST
Attachments

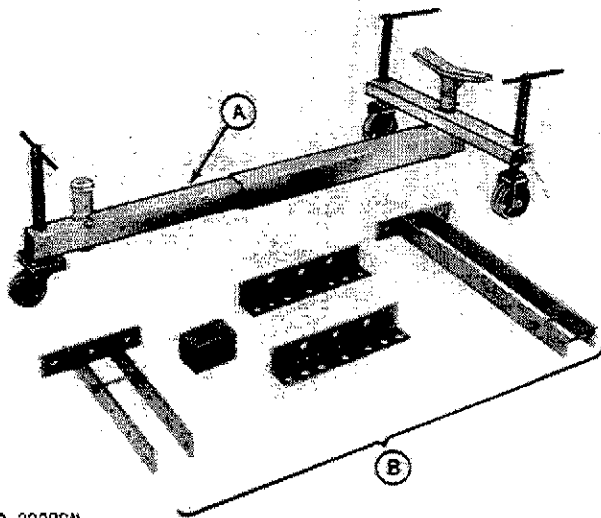

R 28088N

Fig. 10-Splitting Stand*

JDG-12-1
Splitting Stand

To support front end of tractor.

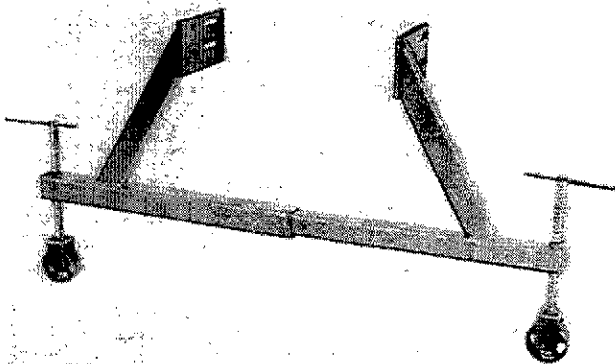

R 26619N

Fig. 11-Splitting Stand*

TOOL	NUMBER	USE
	A-JDE-63 Engine Lift Brackets	To remove engine
	B-JDG-23 Engine Lift Sling	

Fig. 12-Engine Removal Tools*

	D-05001ST Repair Stand	To support engine during repair.
--	------------------------	----------------------------------

Fig. 13-Engine Repair Stand*

*Tools marked with an asterisk can be ordered from Service Tools, Box 314, Owatonna MN 55060.

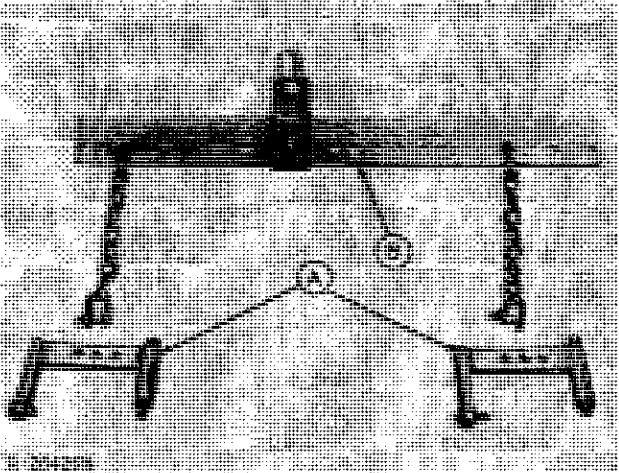
Group 05 PREDELIVERY, DELIVERY, AND AFTER-SALE SERVICES

The John Deere delivery receipt, when properly filled out and signed by the dealer and customer, verifies that predelivery and delivery services were satisfactorily performed. When delivering the tractor, give the customer his copy of the delivery receipt and operators manual. Be sure to explain their purpose to him.

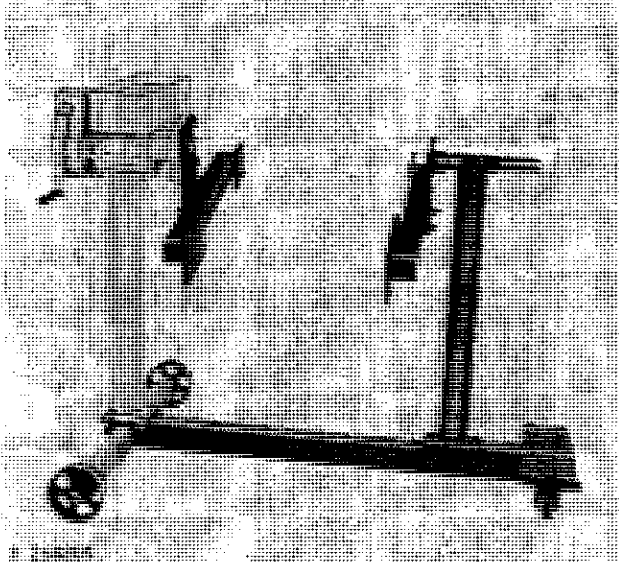
Because of the shipping factors involved, plus extra finishing touches necessary to promote customer satisfaction, there are certain predelivery services that must be performed by the dealer. These services are listed in the first of two sections on the predelivery form, which is attached to the tractor. The second section is a list of factory inspections that must be verified by the dealer.

Fill the form in completely and sign it. Send copy to the factory and file the original with the shop order for the job. This will certify that the proper predelivery service has been completed.

DEALER PREDELIVERY SERVICE

Using the first part of the predelivery form along with the following illustrated procedures, perform all services listed and check each job off as it is completed.

Lubricate Grease Fittings

Grease all fittings with John Deere AT30408 High Temperature Grease (1 lb. [0.45 kg] can) or its equivalent. TY6281 is the same John Deere High Temperature Grease in a 14 oz. (0.39 kg) cartridge. Lubricant must be an extreme-pressure grease with non-soap base and NGLI No. 2 consistency, and must meet John Deere JDM J13 E4 specifications.

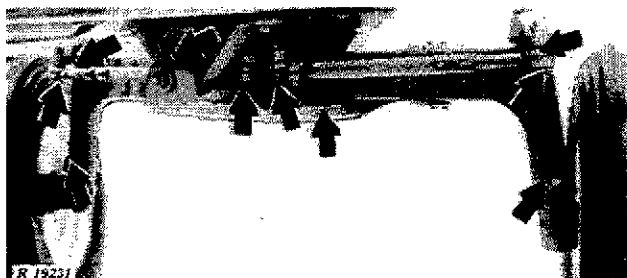

Fig. 1-Grease Fittings

1. Apply several shots of grease to tie rods, pivot pins, and the steering spindles (10 fittings).

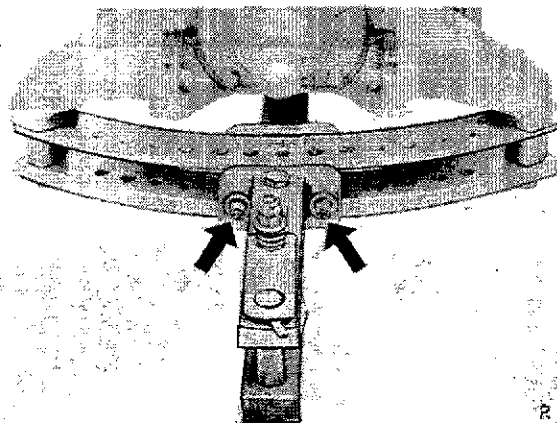

Fig. 2-Wide Swing Drawbar Grease Fittings

2. If tractor is equipped with a wide-swing drawbar (Fig. 2), apply several shots of John Deere High Temperature Grease or its equivalent to drawbar rollers.

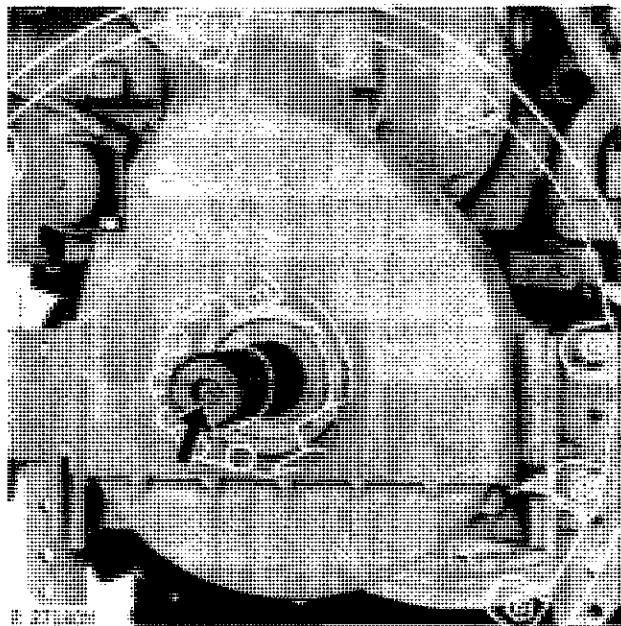

Fig. 3-Hi-Crop Rear Axle Grease Fitting

3. On Hi-Crop tractors, apply several shots of John Deere High Temperature Grease or its equivalent to grease fittings on ends of rear axles.

Lubricate Grease Fittings—Continued



Fig. 4-Radius Rod Pivot Grease Fitting

4. On Hi-Crop tractors, apply several shots of John Deere High Temperature Grease or its equivalent to grease fittings.

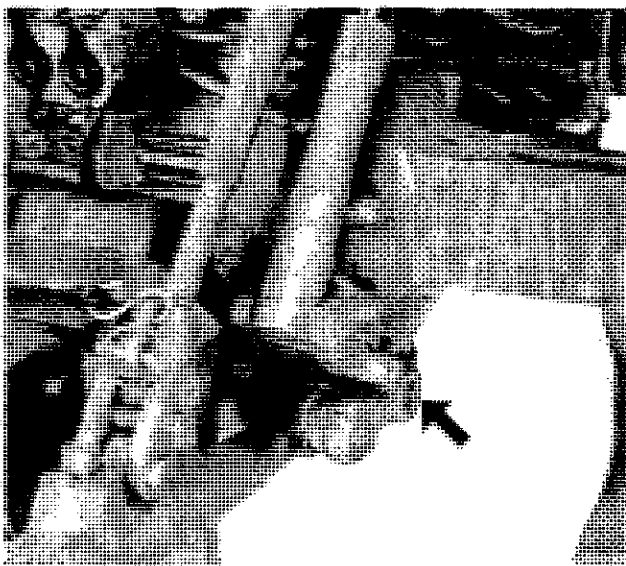

Fig. 5-Load Control Shaft Bushing Grease Fitting

5. Apply several shots of John Deere High Temperature Grease or its equivalent to each load control shaft bushing.

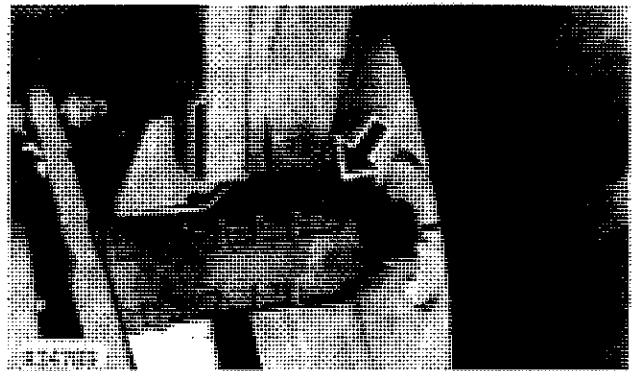

Fig. 6-Rear Axle Grease Plug

6. Grease the rear axle bearings by removing the pipe plug on each end of the axle housing, installing a grease fitting and applying John Deere High Temperature Grease or its equivalent at each fitting. Apply grease until grease appears at seals, or a maximum of 25 shots.

Install Ether Aid Solenoid Wiring (if equipped)

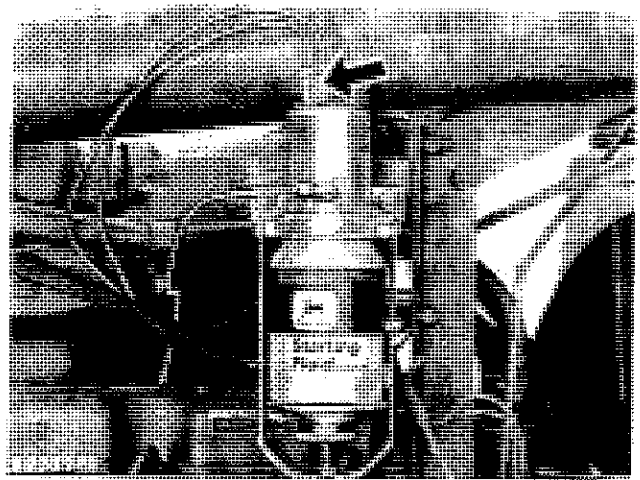

Fig. 7-Electric Starting Aid Connector

Connect starting aid wiring to starting aid solenoid (if equipped).

Align Muffler and Air Stack

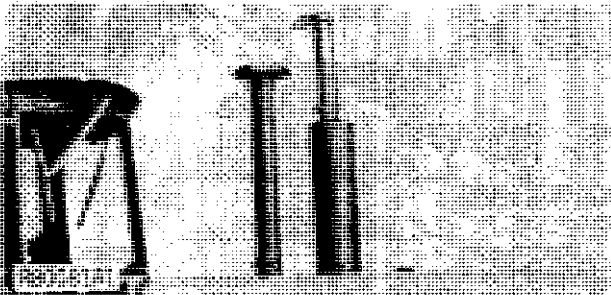

Fig. 8-Muffler and Air Stack

If necessary, align muffler and air stack so they are perpendicular to tractor hood.

Adjust All Lamps

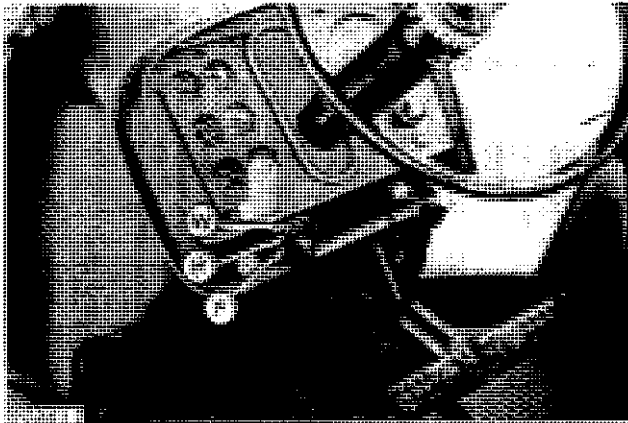
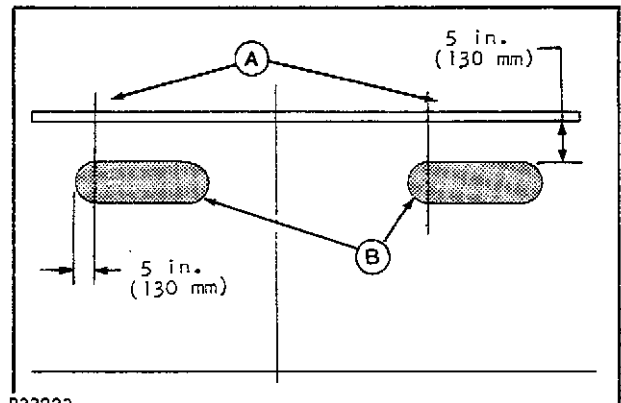

Fig. 9-Light Switch

Make sure lights work properly in the following positions:

- OFF - To turn off lights.
- W - To turn on the warning lamps.
- H - To turn on the dual-beam head lamps, warning lamps, and red tail lamps.
- F - To turn on the dual-beam head lamps and flood lamps.

Head Lamps



R33823

A—Points Directly in Front of Lamps
B—Small Zones of Bright Light

Fig. 10-Checking Head Lamp Positions

1. Park tractor on level ground, 25 feet (8 m) from a wall.
2. Measure height of lamps above ground, and place a strip of masking tape on wall at same height.
3. Sight across steering wheel and hood ornament to locate tractor centerline. Mark this spot, and measure out one foot (300 mm) in each direction. This locates a spot directly in front of each lamp.
4. Turn light switch to "H" and dimmer switch to low beam.
5. Locate small zone of bright light projected by each lamp. Top of bright zone should be five inches (130 mm) lower than lamp, and left edge of zone should be five inches (130 mm) to left of lamp. Cover other lamp if necessary.

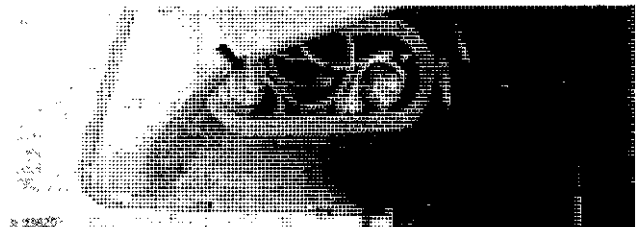

Fig. 11-Head Lamp Adjusting Nut

6. To readjust a bulb, loosen nut behind bulb. Hold lamp in correct position, and tighten securely.

Remove SMV Plastic Cover

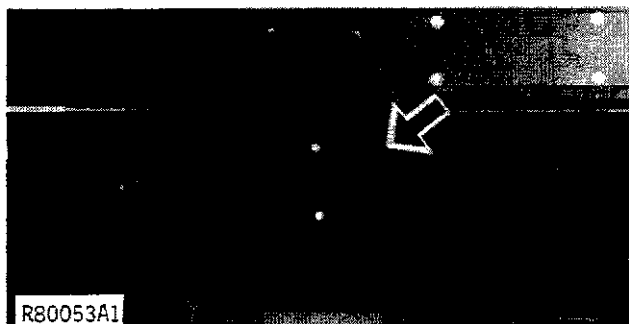

Fig. 12-Plastic Cover

Remove plastic cover from SMV emblem.

Remove Rockshaft Lift Arm Retaining Wire

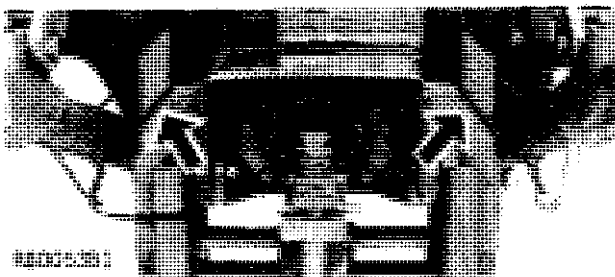
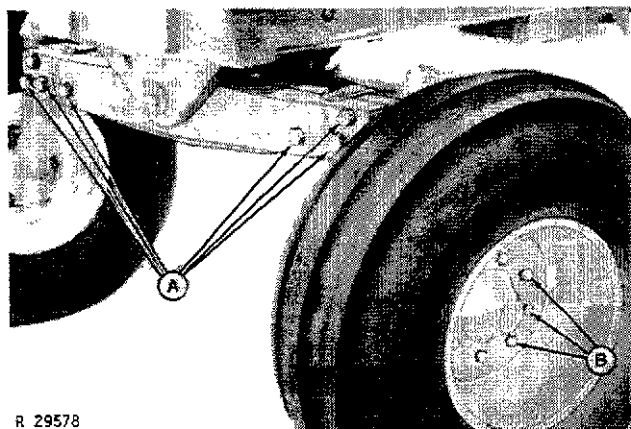

Fig. 13-Retaining Wire

Remove retaining wire from rockshaft lift arms.

Torque Wheel Hardware To Specifications



A—Axle Cap Screws

B—Front Wheel Cap Screws

Fig. 14-Front Axle Cap Screws

1. Torque axle cap screws (A, Fig. 14) to 320 ft-lbs (435 N·m) (44 kgm) (Narrow Axle), 370 ft-lbs (500 N·m) (50 kgm) (Regular or Wide Axle) or 445 ft-lbs (600 N·m) (60 kgm) (Hi-Crop).

2. Torque front wheel cap screws to 100 ft-lbs (135 N·m) (14 kgm).

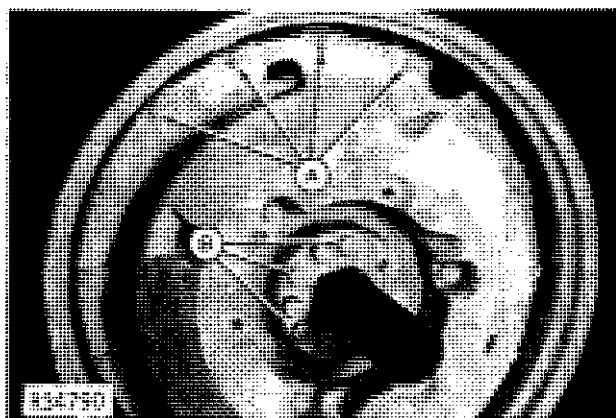

A—Rim Clamp Cap Screws

B—Special Bolts

Fig. 15-Rear Wheel Cap Screws

3. Torque rim clamp cap screws (A, Fig. 15) to 170 ft-lbs (230 N·m) (23 kgm).

4. Torque special bolts (B) to 300 ft-lbs (410 N·m) (41 kgm).

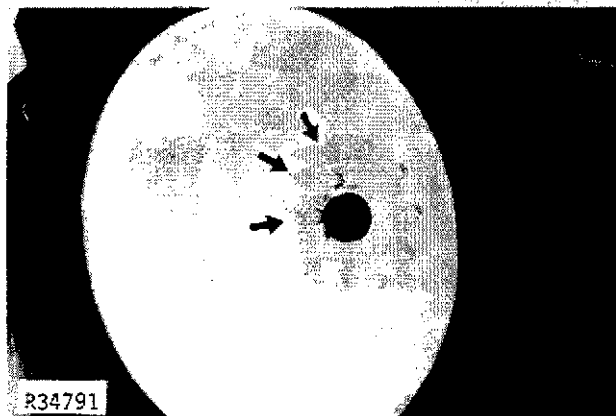

Fig. 16-Rear Wheel Bolts

5. Torque wheel bolts to 300 ft-lbs (410 N·m) (41 kgm) (10-bolt wheel), 240 ft-lbs (325 N·m) (33 kgm) (9-bolt wheel with retaining ring) or 85 ft-lbs (110 N·m) (11 kgm) (9-bolt wheel without retaining ring).

Check Tire Pressure

Make sure tire pressure meets the specifications in the chart below.

Tire Size	Ply Rating	Maximum Pressure
Front Tires		
7.5L-15	6	44 psi (3.1 bar)
7.50-16	6	40 psi (2.8 bar)
7.50-18	6	36 psi (2.5 bar)
7.50-20	6	32 psi (2.2 bar)
9.5L-15	6	32 psi (2.2 bar)
10.00-16	6	24 psi (1.7 bar)
11.00-16	8	24 psi (1.7 bar)
11L-15	6	24 psi (1.7 bar)
12.4-24	8	16 psi (1.1 bar)
Rear Tires		
12.4-42	6	22 psi (1.5 bar)
13.6-38	6	22 psi (1.5 bar)
15.5-38	6	20 psi (1.4 bar)
15.5-38	8	22 psi (1.5 bar)
16.9-34	6	16 psi (1.1 bar)
16.9-34	8	16 psi (1.1 bar)
16.9-38	8	16 psi (1.1 bar)
18.4-34	6	16 psi (1.1 bar)
18.4-34	8	16 psi (1.1 bar)
18.4-38	6	16 psi (1.1 bar)
18.4-38	8	16 psi (1.1 bar)
20.8-34	6	14 psi (1.0 bar)
20.8-34	8	16 psi (1.1 bar)
23.1-30	8	16 psi (1.1 bar)

Adjust Wheel Spacing

Front Tread

Front axle is adjustable in four-inch (100 mm) steps within the ranges shown below.

FRONT TREAD RANGE			
Front Tire Size	Narrow Axle	Regular Axle	Wide Axle
7.5L-15	50 to 76" (1.27 to 1.93 m)	54 to 84" (1.37 to 2.13 m)	60 to 94" (1.52 to 2.39 m)
7.50-16	50 to 75" (1.27 to 1.91 m)	54 to 84" (1.37 to 2.13 m)	60 to 93" (1.52 to 2.36 m)
7.50-18	50 to 75" (1.27 to 1.91 m)	54 to 83" (1.37 to 2.11 m)	60 to 93" (1.52 to 2.36 m)
9.5L-15	51 to 75" (1.30 to 1.91 m)	55 to 83" (1.40 to 2.11 m)	61 to 93" (1.55 to 2.36 m)
10.00-16	52 to 74" (1.32 to 1.88 m)	56 to 82" (1.42 to 2.08 m)	62 to 92" (1.57 to 2.34 m)
11L-15	53 to 73" (1.35 to 1.85 m)	57 to 81" (1.45 to 2.06 m)	63 to 91" (1.60 to 2.31 m)
11.00-16	53 to 73" (1.35 to 1.85 m)	57 to 81" (1.45 to 2.06 m)	63 to 91" (1.60 to 2.31 m)
12.4-24**	Not Available	64 to 84**** (1.63 to 2.13 m)	Not Available
7.50-20*	Not Available	60 to 88" (1.52 to 2.24 m)	Not Available

*Hi-Crop Tractors Only

**Power Front-Wheel Drive Tractors Only

***With 12.4-24 R2 tires, minimum tread on 4240 tractor is 68" (1.73 m)

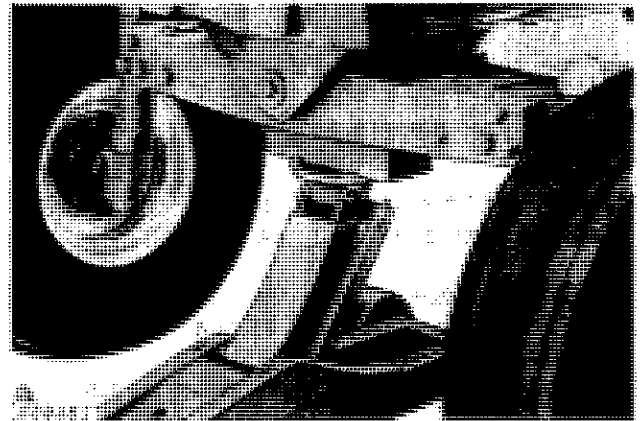

Fig. 17-Jacking Up Tractor

1. Jack up front end of tractor.

IMPORTANT: Do not place jack under engine oil pan. On tractors with power front-wheel drive, do not place jack under hose guard at front axle.

Adjust Wheel Spacing—Continued

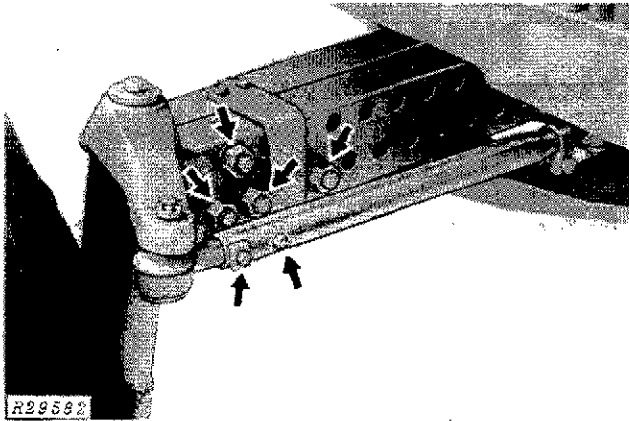

Fig. 18-Front Axle Bolts

2. Remove bolt from tie rod.
3. Remove bolts from front axle.
4. Slide axle knee to desired position.
5. Install axle bolts. On narrow axles, tighten to 320 ft-lbs (435 N·m) (44 kgm). On regular and wide axles, tighten to 370 ft-lbs (500 N·m) (50 kgm). On Hi-Crop axles, tighten to 445 ft-lbs (600 N·m) (60 kgm).

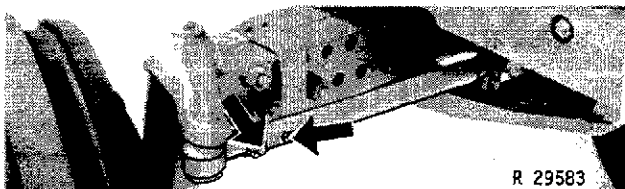

Fig. 19-Tie Rod Bolts

6. Install bolts in tie rod, making sure tie rod is changed same amount as axle.
7. Adjust other side in same manner. Both sides should normally be adjusted to same spacing.
8. Check toe-in each time tread is adjusted.

Reversing Wheel Disk

With 7.5L-15, 7.50-16, 7.50-18, 7.50-20, 9.5L-15, 9.50-20, or 10.00-16 front tires, wheels are reversible. With larger tire sizes, wheel dish must be turned outward for tire clearance.

Tread is 2 to 5 inches (50 to 130 mm) narrower with wheel dish turned inward.

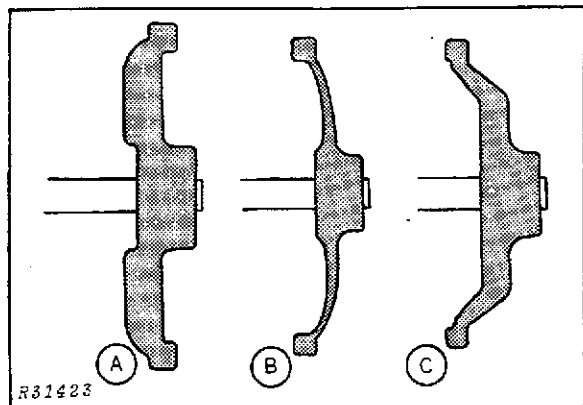

Fig. 20-Lug Bolts

Tighten lug bolts to 100 ft-lbs (135 N·m) (14 kgm) torque. Check and retighten as instructed on page 10-05-4.

Rear Tread Limitations

Approximate tread ranges for each tire size are shown in the chart on the following page.

A—Heavy Cast Wheel
B—Offset Cast Wheel

C—Heavy Offset Cast Wheel

Fig. 21-Wheel Types

Certain tire sizes are available with different wheel types which permit different tread ranges. Types of wheels are illustrated at left.

Tread range for Hi-Crop Tractors is 73 to 97 inches (1.85 to 2.46 m) for straight wheels or 73 to 102 inches (1.85 to 2.59 m) for offset wheels.

Tread adjustment is usually made with the rack and pinion, but you may need to change rim position on wheels or reverse wheels on axles to reach certain tread widths.

CAUTION: For tractor stability, never operate with single tires having tread width less than 60 inches (1.50 m).

Tread is measured between centers of tires.

TIRE SIZE	WHEEL TYPE	RIM POSITION	RIM CLAMP	LONG AXLE	SPECIAL DUAL AXLE
				96 in. (2.44 m) End-to-end	113 in. (2.78 m) End-to-end
15.5-38	Heavy Cast	Inner	Inside Wheel	60 to 82 in. (1.52 to 2.08 m)	66 to 99 in. (1.65 to 2.52 m)
16.9-34		Inner	Outside Wheel	65 to 89 in. (1.66 to 2.25 m)	72 to 106 in. (1.82 to 2.69 m)
16.9-38		Outer	Inside Wheel	67 to 90 in. (1.69 to 2.28 m)	73 to 107 in. (1.85 to 2.72 m)
18.4-34		Outer	Outside Wheel	73 to 96 in. (1.86 to 2.45 m)	80 to 114 in. (2.02 to 2.89 m)
18.4-38					
15.5-38	Offset Cast	Inner	Inside Wheel	60 to 76 in. (1.52 to 1.92 m)	61 to 96 in. (1.56 to 2.43 m)
16.9-34		Inner	Outside Wheel	60 to 82 in. (1.52 to 2.09 m)	65 to 100 in. (1.66 to 2.53 m)
16.9-38		Outer	Inside Wheel	60 to 83 in. (1.53 to 2.12 m)	67 to 101 in. (1.69 to 2.56 m)
18.4-34		Outer	Outside Wheel	67 to 90 in. (1.70 to 2.29 m)	73 to 107 in. (1.86 to 2.73 m)
18.4-38					
20.8-34	Heavy Cast	Inner	Inside Wheel	63 to 82 in. (1.60 to 2.08 m)	65 to 99 in. (1.65 to 2.52 m)
		Inner	Outside Wheel	65 to 89 in. (1.66 to 2.25 m)	72 to 106 in. (1.82 to 2.69 m)
		Outer	Inside Wheel	67 to 90 in. (1.69 to 2.28 m)	73 to 107 in. (1.85 to 2.72 m)
		Outer	Outside Wheel	73 to 96 in. (1.86 to 2.45 m)	80 to 114 in. (2.02 to 2.89 m)
20.8-34	Offset Cast	Inner	Inside Wheel	63 to 76 in. (1.60 to 1.92 m)	61 to 96 in. (1.56 to 2.43 m)
		Inner	Outside Wheel	63 to 82 in. (1.60 to 2.09 m)	65 to 100 in. (1.66 to 2.53 m)
		Outer	Inside Wheel	63 to 83 in. (1.60 to 2.12 m)	67 to 101 in. (1.69 to 2.56 m)
		Outer	Outside Wheel	67 to 90 in. (1.70 to 2.29 m)	73 to 107 in. (1.86 to 2.73 m)
23.1-30	Heavy Cast	Inner	Outside Wheel	66 to 79 in. (1.68 to 2.02 m)	66 to 97 in. (1.68 to 2.46 m)
		Outer	Outside Wheel	73 to 95 in. (1.86 to 2.42 m)	79 to 113 in. (2.02 to 2.86 m)

- IMPORTANT:**
1. Tires must have at least one inch (25 mm) clearance with fenders. Clearance between tires must be at least 42 inches (1.07 m), with tires equal distances from center line.
 2. With dual tires, space between tires must be at least four inches (100 mm).
 3. With single tires, do not exceed 110 inches (2.80 m) for pulling heavy loads.
 4. Pinion might be damaged if hub is tightened at its very innermost position. Back away from end of rack at least 1/8 inch (3 mm).

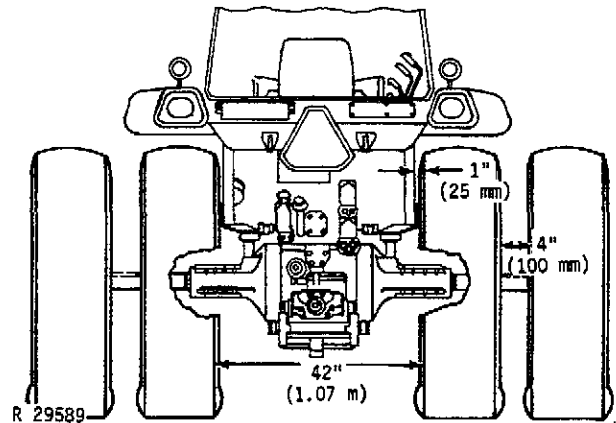
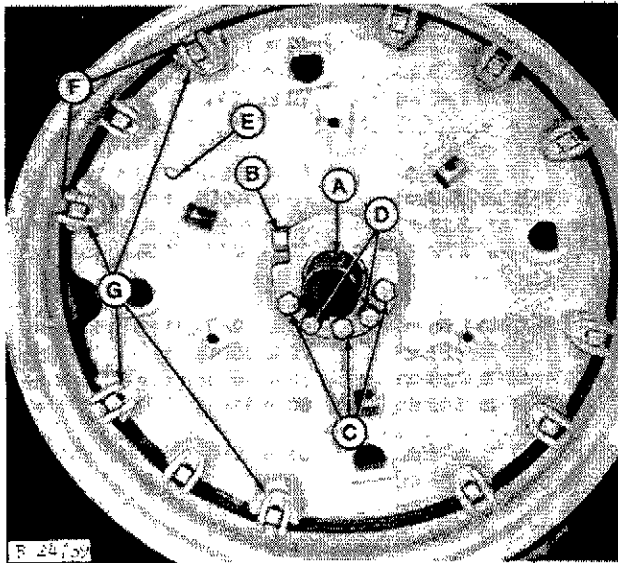

Fig. 22-Minimum Clearances

Adjust Rack and Pinion Wheel



A—Rack
B—Pinion
C—Special Bolts
D—Jack Screws
E—Weight Reference Mark
F—Rim Driving Lugs
G—Wheel Driving Lugs

Fig. 23-Rack and Pinion Wheel

Adjust rear tread width to customer's needs.

CAUTION: Unless tractor is equipped with double rear wheels, tread width must be at least 60 inches (1.52 m) for tractor stability.

1. Jack up tractor. Rotate wheel so that rack is on top of axle.
2. If needed, clean axle with a steel brush.
3. Loosen the three special bolts (C, Fig. 23) approximately 3/8 inch (10 mm) each.
4. Tighten the two jack screws (D) evenly until key sleeve loosens.

NOTE: If sleeve is difficult to break loose, also loosen the three special bolts on inboard side of wheel. If sleeve still will not break loose, strike end of axle several times with a heavy hammer and evenly re-tighten jack screws. It helps to soak sleeves with penetrating oil.

5. Turn pinion (B) to slide wheel in or out on axle to desired position. For extreme tread positions, it may be necessary to reverse wheel on axle or change rim position on wheel.

IMPORTANT: Tires or weights must have at least one inch (25 mm) clearance with fenders. To prevent damaging pinion when hub is tightened, do not put wheel in its very innermost position—back it out at least 1/8 inch (3 mm).

6. Back jack screws all the way out against stop. Do not force.

7. Lubricate threads and tighten special bolts to 300 ft-lbs (410 N-m) (41 kgm). Retighten bolts several times until all three stay tightened to specified torque. Jack screws must be free to turn after hub is tightened. If necessary, loosen jack screws further and retighten special bolts.

IMPORTANT: After driving tractor approximately 100 yards (100 m), retighten special bolts to proper torque. Instruct customer to retighten them after 3 hours work and again after 10 hours work, and to keep them tight.

Changing Rim Position On Wheel

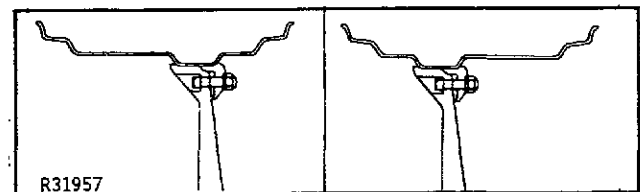

Fig. 24-Deep Well Rim Positions

Deep well rims have only two possible positions on wheels. Wider side of rim can be turned to inside or outside.

NOTE: To change rim position and maintain proper direction of tire rotation, move each tire to opposite side of tractor.

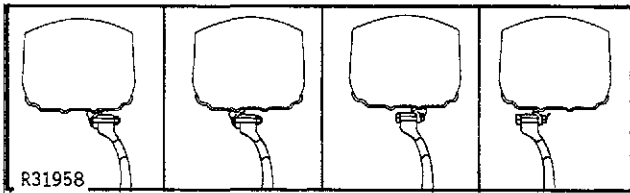

Fig. 25-Rim Positions for Rims with Double Rings

Rims with double rings have four possible positions on wheels. Clamps can be mounted on either side of wheel and can engage either ring on rim.

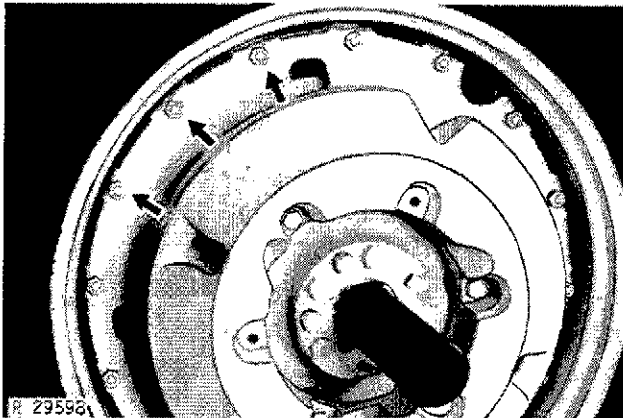

Fig. 26-Rim Clamp Bolts

Be sure clamps engage rim driving lugs.

Tighten clamps evenly. Strike each bolt head with a hammer to seat bolts; then retighten bolts to 170 ft-lbs (230 N-m) (23 kgm) torque. Check and retighten bolts as instructed on page 10-05-4.

Reversing Wheels on Axles

NOTE: To reverse wheels on axles and maintain proper direction of tire rotation, move each wheel to opposite side of tractor.

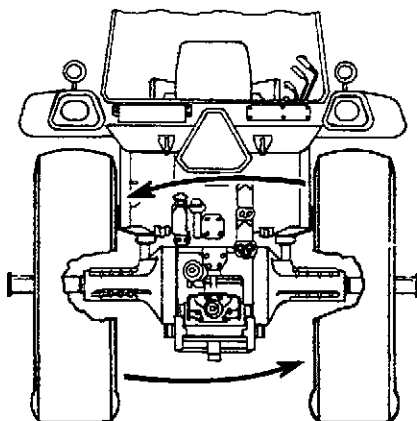
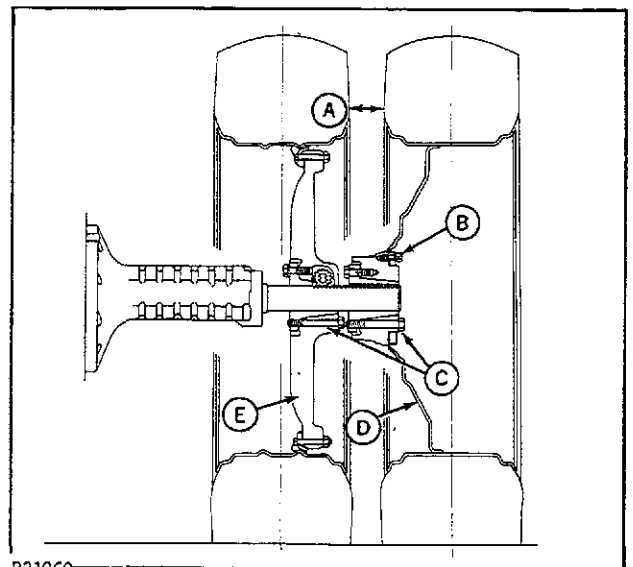

Fig. 27-Reversing Wheels

1. Remove snap rings from ends of axles.
2. Following instructions under "Adjusting Rack and Pinion" on page 10-05-8, slide wheels off axles. Install on opposite axles.
3. Install snap rings on ends of axles.
4. With two jack screws backed all the way out to stops, tighten three special bolts to 300 ft-lbs (400 N-m) (40 kgm) torque. Check and retighten as instructed on page 10-05-8.

Dual Wheels



R31960

- | | |
|--------------------------------|--------------------|
| A—4-in. (100 mm) Minimum Space | D—Steel Disk Wheel |
| B—Retaining Bolts | E—Cast Iron Wheel |
| C—Special Bolts | |

Fig. 28-Dual Wheels

- IMPORTANT:**
1. Space between tires (A) must be at least four inches (100 mm).
 2. Tighten and retighten retaining bolts.
 3. Be sure hub special bolts (C) and rim clamps are kept tight.
 4. When removing a wheel for single wheel operation, always remove steel disk wheel (D) and operate tractor on cast iron wheel (E).

Check Rear Wheel Alignment

1. Jack up rear of tractor until one wheel is off ground.

CAUTION: Make sure differential lock is NOT engaged.

2. Start tractor and place transmission in lowest gear.

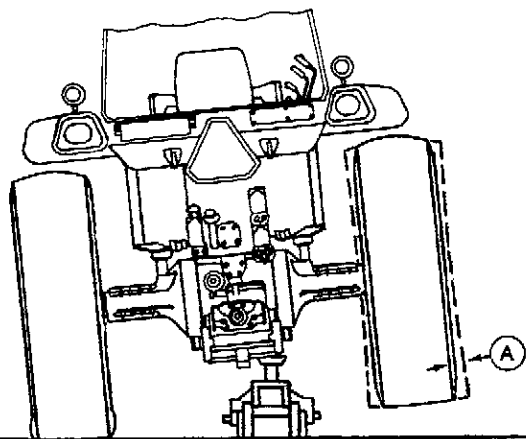

R34753

A—Run-Out

Fig. 29-Checking Tire Run-Out

3. Engage clutch and make sure tire runs straight.
4. If tire does not run straight, loosen rim clamp bolts.
5. Tighten rim clamp bolts evenly, alternating from one side of rim to the other.
6. Run tractor again to check alignment.
7. Check alignment of other wheel.

Adjust Front Wheel Toe-In

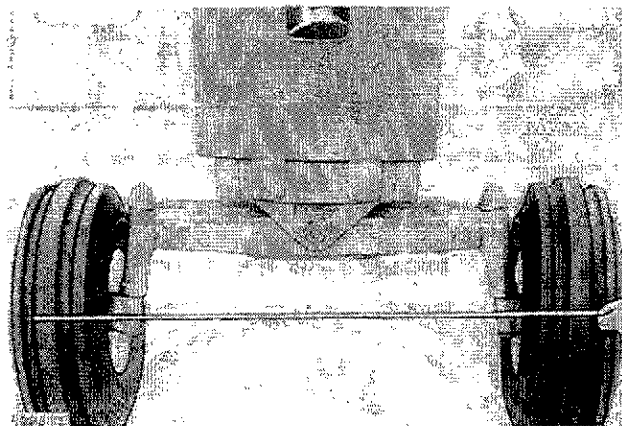

Fig. 30-Checking Toe-In

1. Steer front wheels straight ahead.
2. Measure distance between tires at hub level. Mark the point at which you measured.
3. Move tractor back about three feet (one meter), so mark is at hub level behind the axle. Again measure distance between tires, at same point on tire. Tires should be 1/8 to 3/8 in. (3 to 9 mm) closer in front.

Engine Break-In

Follow procedures for engine break-in as instructed on page 220-10-1.

INSPECTION CHECKS

The second part of the predelivery form is a list of factory inspections that must be verified by the dealer. Use this part of the predelivery form along with the following illustrated procedures to check and verify each item on the list.

1. Check engine oil level. If necessary, add sufficient oil to bring oil level to full mark on dipstick.

2. Check tension of belts. Tension of both alternator and compressor belts should be 85 to 95 lbs. (375 to 425 N).

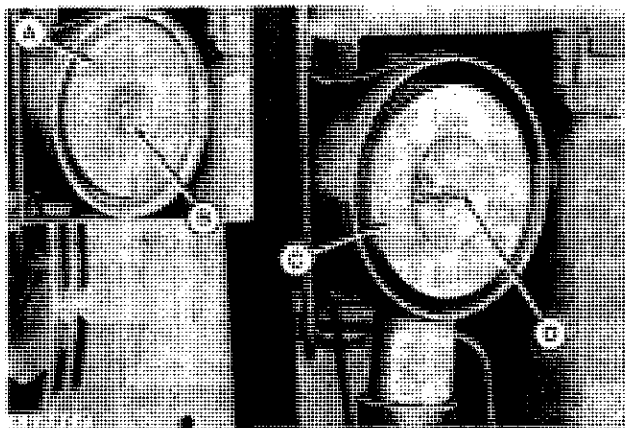

A—Cover
B—Wing Nut
C—Primary Element
D—Wing Nut

Fig. 31-Primary Element and Cover

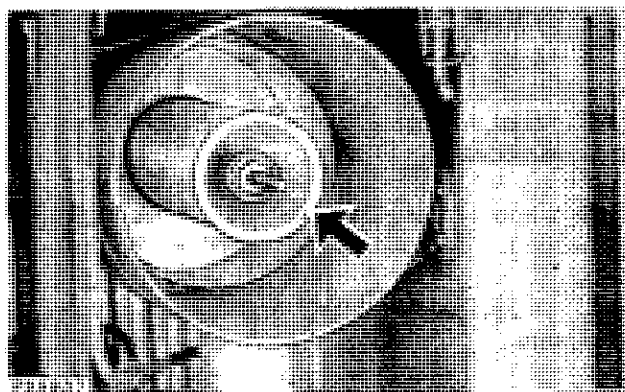

Fig. 32-Secondary Element

3. Make sure air cleaner elements are installed correctly.

4. Check engine coolant level. Proper level is mid-way between filler neck and top of radiator core.

5. Check transmission/hydraulic system oil level. If necessary, add oil to bring to upper mark on dipstick.

6. Check installation of safety shields, handrails and steps. Be sure mounting hardware is tight.

7. Check wheel retainer snap rings on axles. Make sure they are properly seated in groove on axles.

8. Check installation of SOUND-GARD body mounts. Be sure mounting hardware is tight.

9. Check specific gravity of batteries. If reading is below 1.215, battery must be recharged. If difference between cells is more than 0.50, replace battery.

10. Check instrument panel gauges and lights for proper operation.

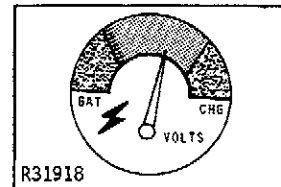

Fig. 33-Voltmeter Gauge

A - Turn key switch to first position. Voltmeter (Fig. 33) hand should rise to green band.

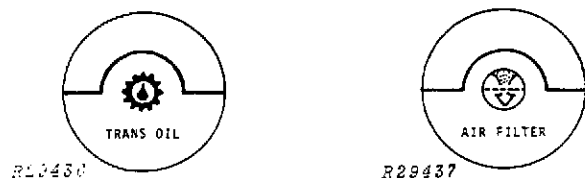

Fig. 34-Transmission Oil and Air Filter Gauges

B - While cranking engine, check transmission oil and air filter indicator lights (Fig. 34). Both bulbs should light while key switch is in start position.

INSPECTION CHECKS—Continued

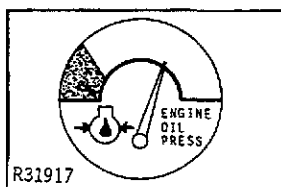

Fig. 35-Oil Pressure Gauge

C - Make sure oil pressure gauge hand rises above warning zone within five seconds after engine starts.

11. Check operation of lights in all switch positions:

OFF - To turn lights off.

W - To turn on the warning lamps.

H - To turn on the dual-beam head lamps, warning lamps, and red tail lamps.

F - To turn on the dual-beam head lamps and flood lamps.

12. Check start-safety switch operation. Make sure engine will start only with transmission in neutral or park.

13. Make sure clutch pedal is adjusted correctly. The lowest part of clutch pedal should be 5-1/4 to 5-3/4 in. (133 to 146 mm) above the footrest.

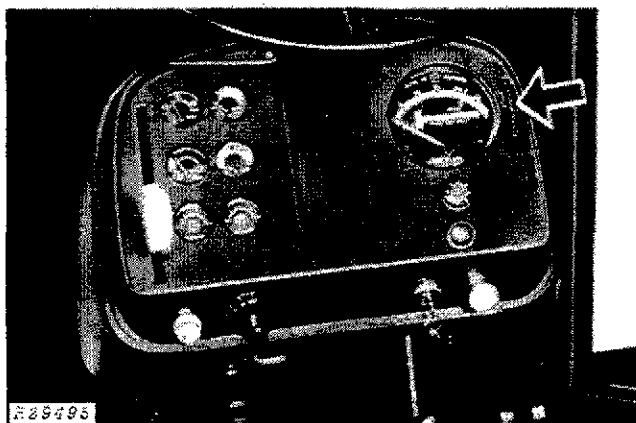

Fig. 36-Tachometer

14. Check engine idle speeds on tachometer (Fig. 36). Fast idle should be 2400 rpm and slow idle should be 800 rpm.

15. Check operation of engine stop knob. Make sure engine stops when knob is pulled out.

16. Make sure steering operates properly in a full left and full right turn.

17. Make sure brakes function properly with engine running. Make sure brakes have a solid feel for at least five applications after engine has been stopped for at least 15 minutes.

18. Check steering wheel tilt and telescope mechanisms.

19. Make sure transmission operates properly in all gears.

20. Check operation of differential lock if equipped. While driving tractor, depress differential lock pedal. Pedal should remain engaged until brakes are used. Pedal should release when either brake pedal is depressed.

21. Raise and lower rockshaft several times to make sure it functions properly.

22. Check SCV operation. Attach a remote hydraulic cylinder to a breakaway coupler. See that coupler, coupler operating levers, and rate of operation valve function smoothly.

Extend and retract cylinder several times. Make sure operation lever automatically returns to neutral when cylinder reaches end of its stroke.

23. Make sure PTO is operating correctly. With PTO guard removed and engine running, make sure PTO shaft rotates when PTO clutch lever is engaged and stops when lever is disengaged.

24. Make sure all seat controls operate properly.

25. Make sure seat belts are installed, if required, and operational.

26. Inspect all coolant, fuel and oil lines for leaks, and correct if necessary.

27. Inspect paint and decals for defects. Correct as necessary.

DELIVERY SERVICE

A thorough discussion of the operation and service of a new tractor at the time of delivery helps to assure complete customer satisfaction. Proper delivery should be an important phase of a dealer's program. A portion of the John Deere Delivery Receipt emphasizes the importance of proper delivery service.

Many complaints have arisen simply because the owner was not shown how to operate and service his new tractor properly. Enough time should be devoted, at the customer's convenience, to introducing the owner to his new tractor and explaining to him how to operate and service it.

IMPORTANT: Install plug in muffler outlet if transporting tractor to customer. This will prevent damage to the turbocharger caused by air passing through the turbocharger and rotating it without lubrication when the engine is stopped.

The following procedure is recommended before the serviceman and owner complete the delivery acknowledgment portion of the delivery receipt.

Using the tractor operator's manual as a guide, be sure the owner understands these points thoroughly:

1. Controls and instruments.
2. How to start and stop the engine.
3. The importance of the break-in period.
4. How to use liquid or cast-iron ballast.
5. All functions of the hydraulic system.
6. Using the power takeoff.
7. The importance of safety.
8. The importance of lubrication and periodic services.

Give particular emphasis to sway blocks, rockshaft speed-of-drop, rockshaft selector lever (load and depth control), transmission oil indicator light (whether temperature or pressure and what to do if it comes on), voltmeter (how to see whether alternator is charging), and SOUND-GARD Body air filters. These areas are very often misunderstood.

After explaining and demonstrating the above features, have the owner sign the delivery receipt and give him the operator's manual.

AFTER-SALE INSPECTION

The purchaser of a new John Deere tractor is entitled to a free inspection within the warranty period after the equipment has been "run in". The terms of this after-sale inspection are outlined on the back of the John Deere Delivery Receipt.

The purpose of this inspection is to make sure that the customer is receiving satisfactory performance from his tractor. At the same time, the inspection should reveal whether the tractor is being operated, lubricated, and serviced properly.

If the recommended after-sale service inspection is followed, the dealer can eliminate a needless volume of service work by preventing minor irregularities from developing into serious problems later on. This will promote strong dealer-customer relations and present the dealer an opportunity to answer questions that may have arisen during the first few days of operation.

The following inspection program is recommended within the first 100 hours of tractor operation.

Cooling System

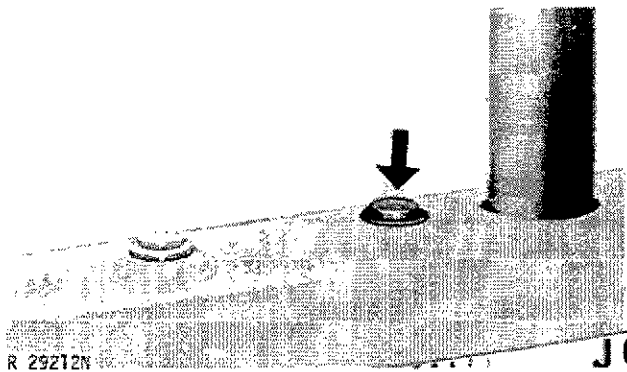

Fig. 37-Radiator Cap

1. Remove radiator cap and check coolant level. Level should be at least 1-1/2-inches (38 mm) above baffle in radiator top tank. If coolant is low, fill to proper level and try to determine why coolant was lost.

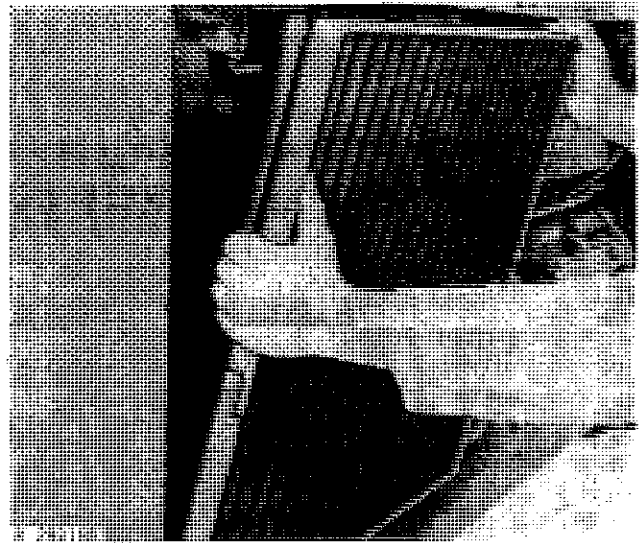

Fig. 38-Removing Side Grille Screen

2. Remove side grille screens. Remove any trash which has accumulated on radiator and oil cooler-condenser.

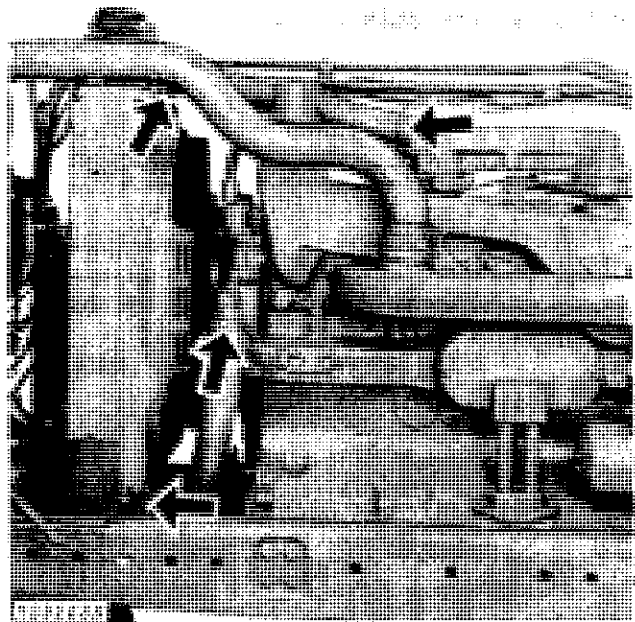

Fig. 39-Cooling System

3. Check all hoses and connections for leaks. Correct as necessary.

Fuel System

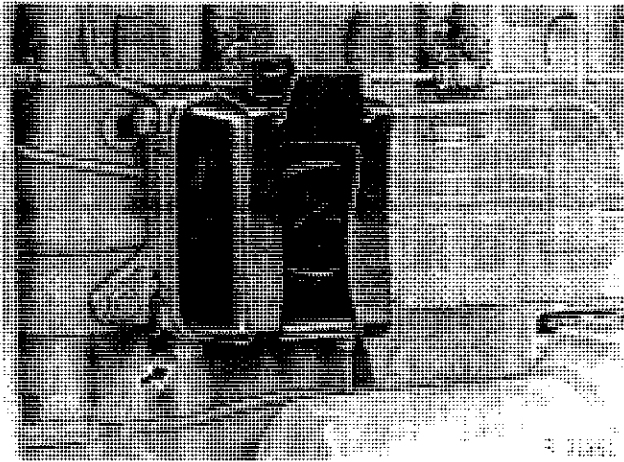

Fig. 40-Fuel Filter Drain Plug

1. Check fuel filter for water or sediment. If any is present, remove drain plug and drain it out. Caution customer about importance of proper fuel storage.

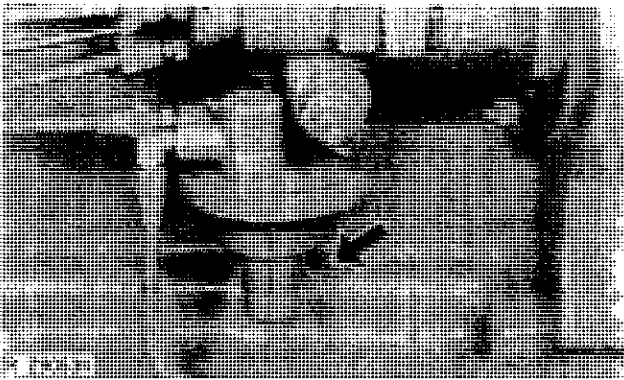
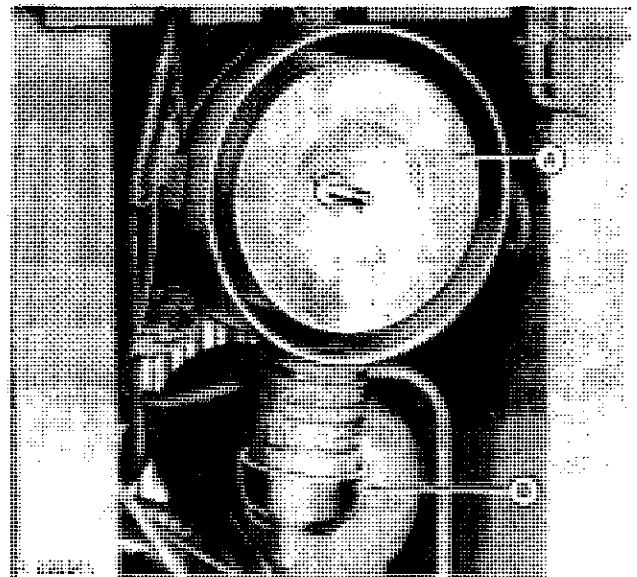

Fig. 41-Fuel Transfer Pump Hand Primer

2. If fuel filter is drained, bleed air from system. Loosen hand primer (Fig. 41) and pump until most of air bubble disappears.

3. Check entire fuel system for leaks. Correct as necessary.



A—Air Cleaner Element

B—Dust Unloading Valve

Fig. 42-Air Cleaner

4. Inspect air cleaner element (A, Fig. 42) and dust unloading valve (B). Clean element if needed.

Lubrication

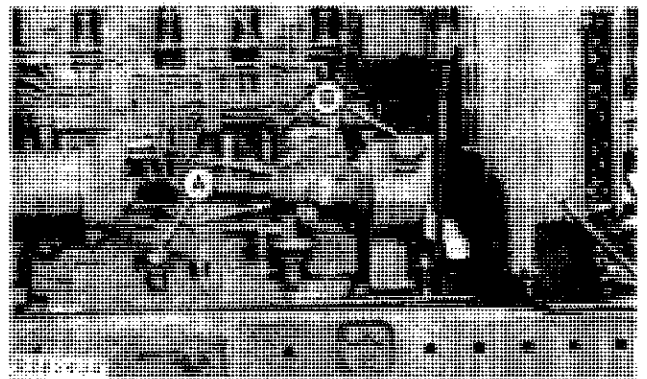

A—Dipstick

B—Filler Cap

Fig. 43-Crankcase Dipstick and Filler Cap

1. With the tractor on level ground and the engine stopped for 10 minutes or more, loosen the dipstick and remove it. Observe the engine oil level on the dipstick, with the dipstick seated evenly. If the oil level is down to the lower marks on the dipstick, add sufficient John Deere TORQ-GARD SUPREME® Engine Oil or its equivalent of the proper viscosity to bring the level to the upper marks.