

Product: John Deere 650 and 750 Tractors Service Repair Technical Manual
Full Download: <https://www.bobmanualstore.com/downloads/john-deere-650-and-750-tractors-service-repair-technical-manual/>



650 and 750 Tractors



JOHN DEERE

TECHNICAL MANUAL

650 and 750
Tractors

TM1242 (01SEP84) English

John Deere
Lawn & Grounds Care Division
TM1242 (01SEP84)

LITHO IN U.S.A.
ENGLISH

Sample manual. Download All 796 pages at:
<https://www.bobmanualstore.com/downloads/john-deere-650-and-750-tractors-service-repair-technical-manual/>



Product: John Deere 650 and 750 Tractors Service Repair Technical Manual
Full Download: <https://www.bobmanualstore.com/downloads/john-deere-650-and-750-tractors-service-repair-technical-manual/>

Sample manual. Download All 796 pages at:
<https://www.bobmanualstore.com/downloads/john-deere-650-and-750-tractors-service-repair-technical-manual/>

650 AND 750 TRACTORS TECHNICAL MANUAL TM-1242 (MAR-81)

CONTENTS—REPAIR SECTIONS

SECTION 10—GENERAL

- Group 00—Specifications and Special Tools
- Group 05—Predelivery, Delivery and After-Sale Services
- Group 10—Tune-Up
- Group 15—Lubrication
- Group 20—650 Separation
- Group 25—750 Separation

SECTION 20—ENGINE REPAIR

- Group 00—Specifications and Special Tools
- Group 05—Valve Train, Cylinder Head and Camshaft
- Group 10—Pistons, Rods, and Cylinder Blocks
- Group 15—Flywheel, Crankshaft, and Main Bearings
- Group 20—Lubrication System
- Group 25—Cooling System

SECTION 30—FUEL AND REPAIR

- Group 00—Specifications and Special Tools
- Group 05—Air Intake System
- Group 10—Diesel Fuel System
- Group 15—Speed Control Linkage

SECTION 40—ELECTRICAL REPAIR

- Group 00—Specifications and Special Tools
- Group 05—General Information
- Group 10—Charging System
- Group 15—Starting Motor
- Group 20—Instruments and Accessory Circuits
- Group 25—Lighting Circuits

SECTION 50—650 POWER TRAIN REPAIR

- Group 00—Specifications and Special Tools
- Group 05—Engine Clutch and Linkage

- Group 10—Sliding Gear Transmission
- Group 15—Rear PTO
- Group 20—Differential
- Group 25—Final Drive
- Group 30—Mechanical Front-Wheel Drive
- Group 35—Front PTO

SECTION 55—750 POWER TRAIN REPAIR

- Group 00—Specifications and Special Tools
- Group 05—Engine Clutch and Linkage
- Group 10—Sliding Gear Transmission
- Group 15—Rear PTO
- Group 20—Differential
- Group 25—Final Drive
- Group 30—Mechanical Front-Wheel Drive
- Group 35 Front PTO

SECTION 60—STEERING/BRAKES REPAIR

- Group 00—Specifications and Special Tools
- Group 05—Steering Gear Repair
- Group 10—Power Steering Repair (Field Option)
- Group 15—Brakes Repair

SECTION 70—HYDRAULIC REPAIR

- Group 00—Specifications and Special Tools
- Group 05—Hydraulic Pump Repair
- Group 10—Rockshaft and Implement Hitches
- Group 15—Selective Control Valve Repair

SECTION 80—MISCELLANEOUS REPAIR

- Group 00—Specifications and Special Tools
- Group 05—Front Axle Assembly
- Group 10—Wheels
- Group 15—Operators Station Repair

All information, illustrations and specifications contained in this technical manual are based on the latest information available at the time of publication. The right is reserved to make changes at any time without notice.

COPYRIGHT® 1981
DEERE & COMPANY
Moline, Illinois
All rights reserved
A JOHN DEERE ILLUSTRATION

CONTENTS—OPERATION AND TEST SECTIONS

SECTION 220—ENGINE OPERATION AND TESTS

- Group 00—Specifications and Special Tools
- Group 05—System Operation
- Group 10—System Tests and Diagnosis

SECTION 230—FUEL/AIR OPERATION AND TESTS

- Group 00—Specifications and Special Tools
- Group 05—Air Intake System
- Group 10—Diesel Fuel System
- Group 15—Speed Control Linkage

SECTION 240 ELECTRICAL OPERATION

- Group 00—Specifications and Special Tools
- Group 05—General Information and Diagrams
- Group 10—Charging System
- Group 15—Starting Circuit
- Group 20—Instruments and Accessory Circuits
- Group 25—Lighting Circuits

SECTION 250—650 POWER TRAIN OPERATION AND TESTS

- Group 00—Specifications and Special Tools
- Group 05—Clutch and Transmission Operation
- Group 10—Diagnosing the Clutch, Transmission and Front-Wheel Drive
- Group 15—Differential and Final Drive
- Group 20—Mechanical Front-Wheel Drive Operation

SECTION 255—750 POWER TRAIN OPERATION AND TESTS

- Group 00—Specifications and Special Tools
- Group 05—Clutch and Transmission Operation
- Group 10—Diagnosing the Transmission, and Front-Wheel Drive
- Group 15—Differential and Final Drive
- Group 20—Mechanical Front-Wheel Drive Operation

SECTION 260—STEERING/BRAKES OPERATION AND TEST

- Group 00—Specifications and Special Tools
- Group 05—Manual Steering
- Group 10—Power Steering
- Group 15—Brakes

SECTION 270—HYDRAULIC OPERATION AND TESTS

- Group 00—Specifications and Special Tools
- Group 05—Hydraulic System Operation
- Group 10—Hydraulic System Tests and Diagnosis
- Group 15—Hydraulic Pump
- Group 20—Rockshaft and Implement
- Group 30—Selective Control Valve



This tractor is of metric design. All hardware is therefore metric. Make sure you use the specified metric hardware when replacement becomes necessary. For your convenience most specifications are given in metric measurement with customary U.S. measurement following.

All information, illustrations and specifications contained in this technical manual are based on the latest information available at the time of publication. The right is reserved to make changes at any time without notice.

Section 10 GENERAL

CONTENTS

GROUP 00 - SPECIFICATIONS AND SPECIAL TOOLS

General Tractor Specifications	10-00-1
Predelivery	10-00-3
Tune-Up	10-00-4
Lubrication	10-00-4
Separation	10-00-5
Special Tools	10-00-5

GROUP 05 - PREDELIVERY, DELIVERY AND AFTER-SALE SERVICES

Predelivery Service-General Information	10-05-1
Lubricate Grease Fittings	10-05-2
Align Muffler	10-05-3
Adjust All Lamps	10-05-4
Torque Wheel Hardware	10-05-4
Check Tire Pressures	10-05-5
Adjust Wheel Spacing-Front Tread	10-05-5
Adjust Wheel Spacing-Rear Tread	10-05-5
Adjust Front Wheel Toe-In	10-05-6
Adjust 650 Tractor Toe-In	10-05-6
Adjust 750 Tractor Toe-In	10-05-6
Engine Break-In	10-05-6
Verify Predelivery Service	10-05-7
Delivery Service	10-05-12
After-Sale Inspection	10-05-13

GROUP 10 - TUNE-UP

Preliminary Engine Tests	10-10-1
Remove and Inspect Air Cleaner Element	10-10-1
Clean Filter Element	10-10-2
Tighten Air Intake Connections	10-10-3
Clean Crankcase Breather System	10-10-3
Clean Radiator Screen	10-10-3
Test Cooling System	10-10-3
Flush Cooling System	10-10-4
Check and Adjust Fan Belt Tension	10-10-4
Clean Fuel Filter	10-10-5
Clean and Adjust Injection Pump Timing	10-10-5
Check and Adjust Fast Idle Speed	10-10-9

Clean and Test Battery	10-10-10
Make Final Engine Test	10-10-11
Check Toe-In	10-10-11
Miscellaneous	10-10-12

GROUP 15 - LUBRICATION

Lubricate Tractor Properly	10-15-1
Use Correct Engine Oil	10-15-1
Use Correct Transmission-Hydraulic Oil	10-15-2
Use Correct Grease	10-15-2
Use Approved Alternative Lubricants	10-15-3
Store Lubricants Correctly	10-15-3
Lubrication Services (Chart)	10-15-4
Check Engine Oil Level	10-15-5
Change Engine Oil and Oil Filter	10-15-5
Clean Crankcase Vent System	10-15-5
Check Transmission-Hydraulic Oil Level	10-15-6
Change Transmission-Hydraulic System Oil	10-15-6
Service Transmission-Hydraulic Filter Screen	10-15-7
Replace Transmission-Hydraulic Oil Filter	10-15-7
Check Front Axle Oil Level (MFWD Tractors Only)	10-15-8
Change Front Axle Oil (MFWD Tractors Only)	10-15-8
Repack Front Wheel Bearings (650 Without MFWD)	10-15-9
Repack Front Wheel Bearings (750 Without MFWD)	10-15-10
Lubricate Steering Linkage	10-15-10
Lubricate Front Axle Pivot (Tractors Without MFWD)	10-15-11
Lubricate Steering Spindles (Tractors Without MFWD)	10-15-11
Lubricate Steering Spindles (650 With MFWD)	10-15-11
Lubricate Clutch and Brake Pedal Pivots	10-15-11
Lubricate 3-Point Hitch	10-15-12
Lubricate Front PTO Shaft Bearing	10-15-12

Continued

010CON A 080181

CONTENTS—Continued

GROUP 20 - SEPARATION

Remove Front End10-20-1
Install Front End10-20-4
Remove Engine10-20-5
Install Engine10-20-7
Remove Front End From Clutch
Housing10-20-8
Install Front End To Clutch Housing10-20-11
Remove Clutch Housing From
Transmission10-20-12
Install Clutch Housing To
Transmission10-20-14
Mount Transmission Stand10-20-15
Remove Axle10-20-16
Install Axle10-20-19

GROUP 25 - 750 SEPARATION

Remove Front End10-25-1
Install Front End10-25-3
Remove Front End From Clutch
Housing10-25-4
Install Front End To Clutch Housing10-25-7
Remove Engine10-25-8
Install Engine10-25-11
Remove Clutch Housing From
Transmission10-25-12
Install Clutch Housing To
Transmission10-25-14
Remove Transmission From
Differential10-25-15
Install Transmission To Differential10-25-17
Mount Transmission Stand10-25-18
Remove Axle10-25-21
Install Axle10-25-23

GENERAL TRACTOR SPECIFICATIONS

	650 TRACTOR	750 TRACTOR
HORSEPOWER (Official PTO horsepower)	10.8 kW (14.5 hp) at 2600 rpm	13.4 kW (18.0 hp) at 2400 rpm
ENGINE:		
Type	2-cylinder, in line, valve-in-head, diesel	3-cylinder, in-line, valve-in-head, diesel
Slow idle speed	800 rpm	800 rpm
Working speed range	1825 to 2600 rpm	1650 to 2400 rpm
Bore and stroke	80 x 85 mm (3.15 x 3.35 in.)	80 x 85 mm (3.15 x 3.35 in.)
Displacement	0.9 L (52.0 cu. in.)	1.3 L (78.0 cu. in.)
Compression ratio	22.5 to 1	22.5 to 1
Firing order (No. 1 in rear)	1-2	1-3-2
Valve clearance		
Intake	0.2 mm (0.008 in.)	0.15 mm (0.006 in.)
Exhaust	0.20 mm (0.008 in.)	0.15 mm (0.006 in.)
Injection pump timing	22°BTDC	22°BTDC
Lubrication system	force-feed, pressurized with full-flow filter	force-feed, pressurized with full-flow filter
FUEL SYSTEM:		
Type	precombustion chamber	precombustion chamber
Injection pump type	plunger	plunger
Air cleaner	dry type	dry type
COOLING SYSTEM:		
Type	pressurized with centrifugal pump	pressurized with centrifugal pump
Temperature control	heavy duty thermostat	heavy duty thermostat
CAPACITIES		
Fuel tank	23.5 L (6.2 U.S. gal.)	23.5 L (6.2 U.S. gal.)
Cooling system	3.5 L (3.7 U.S. qt.)	4.2 L (4.4 U.S. qt.)
Crankcase (with filter change)	2.5 L (2.6 U.S. qt.)	4.0 L (4.2 U.S. qt.)
Transmission-hydraulic system	13 L (14 U.S. qt.)	14 L (15 U.S. qt.)
Front-wheel drive axle housing	3.0 L (3.2 U.S. qt.)	6.5 L (6.9 U.S. qt.)
TRANSMISSION:		
Type	2-speed range selector and 4-speed gear selector	2-speed range selector and 4-speed gear selector
Gear selections	8 forward and 2 reverse	8 forward and 2 reverse
Clutch	single-disk, dry	single-disk, dry
POWER TAKE-OFF:		
Type	transmission driven, with overrunning clutch	transmission driven, with overrunning clutch
PTO Speed (engine speed)	540 rpm (2350 rpm)	540 rpm (2300 rpm)
Size	35 mm (1-3/8 in.)	35 mm (1-3/8 in.)
Clutch	uses transmission clutch	uses transmission clutch

Continued

01000 A 080181

GENERAL TRACTOR SPECIFICATIONS—Continued

	650 TRACTOR	750 TRACTOR
HYDRAULIC SYSTEM:		
Type	open center, constant flow	open center, constant flow
Working pressure	13790 kPa (138 bar) (2000 psi)	13790 kPa (138 bar) (2000 psi)
Pump	gear pump, driven by engine	gear pump, driven by engine
BRAKES		
Type	mechanical dry, internal expanding shoe	mechanical dry, internal expanding shoe
ELECTRICAL SYSTEM:		
Type	12-volt, negative ground	12-volt, negative ground
Battery	one, 12-volt, BCI group, 24 370 amps cold cranking, 106 minutes reserve capacity	one, 12-volt, BCI group, 24 370 amps cold cranking, 106 minutes reserve capacity
Alternator	15-amp	15-amp
TIRES AND TREADS:		
	See page 10-05-5	See page 10-05-5
DIMENSIONS:		
Wheelbase	1425 mm (56 in.)	1550 mm (61 in.)
Overall length	2606 mm (102.5 in.)	2845 mm (112.0 in.)
Height to muffler top*	1965 mm (77.4 in.)	2004 mm (78.9 in.)
Height to top of ROLL-GARD frame*	1865 mm (73.4 in.)	1904 mm (75.0 in.)
Overall width	1041 mm (41.0 in.)	1132 mm (44.6 in.)
Turning radius with brakes	1.9 m (6.2 ft.)	2.2 m (7.2 ft.)
SHIPPING WEIGHT**		
Tractor without MFWD	645 kg (1450 lbs.)	770 kg (1700 lbs.)
Tractor with MFWD	695 kg (1530 lbs.)	860 kg (1896 lbs.)

*650 Tractor equipped with 9.5-16 rear tires and 5.00-12 front tires. 750 Tractor equipped with 9.5-24 rear tires and 4.00-15 front tires.

**Equipped for average field service, without fuel and ballast.

DETERMINING 650 TRACTOR TRAVEL SPEED

Travel speeds shown are for tractor with 9.5-16 rear tires.

Due to difference in tire radius, all speeds would be six percent faster with 31/15.50-15 rear tires.

Range	Gear	Lowest Working Speed (1825 rpm) km/h (mph)	Standard PTO Speed (2350 rpm) km/h (mph)	Rated Engine Speed (2600 rpm) km/h (mph)
L	1	0.9 (0.6)	1.1 (0.7)	1.1 (0.7)
	2	1.1 (0.7)	1.4 (0.9)	1.6 (1.0)
	3	1.6 (1.0)	2.1 (1.3)	2.3 (1.4)
	4	2.6 (1.6)	3.4 (2.1)	3.8 (2.3)
H	5	3.6 (2.2)	4.7 (2.9)	5.2 (3.2)
	6	5.0 (3.1)	6.5 (4.0)	7.2 (4.5)
	7	7.1 (4.4)	9.1 (5.7)	10.1 (6.3)
	8	11.6 (7.2)	15.0 (9.3)	16.6 (10.3)
R	1	0.8 (0.5)	1.0 (0.6)	1.1 (0.7)
	2	1.1 (0.7)	1.4 (2.7)	4.9 (3.1)

01000 B 080181

DETERMINING 750 TRACTOR TRAVEL SPEEDS

Travel speeds shown are for tractor with 9.5-24 rear tires.

Due to difference in tire radius, all speeds would be eight percent faster with 13.6-16 rear tires.

750 TRACTOR TRAVEL SPEEDS

Range	Gear	Lowest Working Speed (1650 rpm) km/h (mph)	Standard PTO Speed (2300 rpm) km/h (mph)	Rated Engine Speed (2400 rpm) km/h (mph)
L	1	0.9 (0.6)	1.3 (0.8)	1.3 (0.8)
	2	1.1 (0.7)	1.6 (1.0)	1.8 (1.1)
	3	1.8 (1.1)	2.5 (1.5)	2.6 (1.6)
	4	2.8 (1.7)	4.0 (2.5)	4.2 (2.6)
H	5	3.9 (2.4)	5.6 (3.5)	5.8 (3.6)
	6	5.2 (3.2)	7.4 (4.6)	7.7 (4.8)
	7	7.6 (4.7)	10.8 (6.7)	11.3 (7.0)
	8	12.3 (7.6)	17.5 (10.8)	18.3 (11.4)
R	1	0.9 (0.6)	1.3 (0.8)	1.4 (0.9)
	2	4.1 (2.5)	5.9 (3.7)	6.2 (3.9)

01000 C 080181

PREDELIVERY

Toe-in 3 to 9 mm (1/8 - 3/8 in.)

ENGINE SPEEDS

Slow Idle 800 rpm
 650 Fast Idle 2800 rpm
 750 Fast Idle 2600 rpm
 650 at Full Load 2600 rpm
 750 at Full Load 2400 rpm

CLUTCH PEDAL FREE TRAVEL

650 Tractor 16 mm (5/8 in.)
 750 Tractor 22 mm (7/8 in.)
 Fan Belt Tension 13 mm (1/2 in.)
 Battery Specific Gravity 98 N (22 lbs.) force
 1.260 at 27°C (80°F)

TORQUES

650 Front and Rear Wheel Bolts 133 N.m (98 ft-lbs)
 750 Front Wheel Bolts 133 N.m (98 ft-lbs)
 750 Rear Wheel Bolts 186 N.m (137 ft-lbs)

01000 D 080181

GENERAL TRACTOR SPECIFICATIONS—Continued

TUNE-UP

PTO Horsepower	
650 Tractor at 2600 rpm	10.8 kW(14.5 hp)
750 Tractor at 2409 rpm	13.4 kW(18.0 hp)
Compression	3914-4403 kPa (39.0-44.0 bar) (568-639 psi)
Thermostat Opening Temperature	71°C (160°F)
Radiator Cap Pressure Release	98 kPa (1.0 bar) (14 psi)
650 Engine Speeds	
Slow Idle	800 rpm
Fast Idle	2800 rpm
Rated Speed at Full Load	2600 rpm
750 Engine Speeds	
Slow Idle	800 rpm
Fast Idle	2600 rpm
Rated Speed at Full Load	2400 rpm
Injection Pump Timing	TDC
Battery Specific Gravity	1.260 at 27°C (80°F)
Front Wheel Toe-In	3-9 mm (1/8 - 3/8 in.)

LUBRICATION

Engine Crankcase Oil Capacity (with filter change)	2.5 L (2.6 U.S. qt.)
Transmission-Hydraulic System Capacity	
650 Tractor	13 L (14 U.S. qt.)
750 Tractor	14 L (15 U.S. qt.)
Front Wheel Drive Axle Housing	
650 Tractor	3.0 L (3.2 U.S. qt.)
750 Tractor	6.5 L (6.9 U.S. qt.)
Service Intervals	
Check Engine Oil Level	Every 10 hours
Change Engine Oil	After first 50 hours and again at 100 hours and then every 200 hours
Replace Engine Oil Filter	Every 200 hours
Clean Crankcase Breather Tube	Every 600 hours
Check Transmission-Hydraulic Oil Level	Every 50 hours
Change Transmission-Hydraulic Oil	
Without Hydraulic Filter	Every 200 hours
With Hydraulic Filter	Every 600 hours
Clean Transmission-Hydraulic Oil Screen	
Without Hydraulic Filter	Every 200 hours
With Hydraulic Filter	Every 600 hours
Replace Transmission-Hydraulic Oil Screen	
Without Hydraulic Filter	Every 600 hours
With Hydraulic Filter	Every 1200 hours
Replace Transmission-Hydraulic Oil Filter	After first 100 hours then every 200 hours
Check Oil Level MFWD Axle	Every 50 hours
Change Oil in MFWD Axle	After first 100 hours then every 600 hours

01000 E 080181

LUBRICATION

Clean and Repack Front Wheel Bearings	Every 600 hours
Lubricate Grease Fittings	
Front Axle Pivot Pin	Every 10 hours
Drag Link Ends	Every 10 hours
Tie Rod Ends	Every 10 hours
Clutch and Brake Pedal Fittings	Every 50 hours
Right-Hand Hitch Lift Link	Every 50 hours
Steering Spindles (without MFWD)	Every 50 hours

SEPARATION

Fan Belt Deflection (at 98 N (22 lbs.) force)	13 mm (1/2 in.)
ROLL-GARD Protection Structure Cap Screws	
Rear	100 N.m (74 ft-lbs)
Side	245 N.m (181 ft-lbs)
Fender-to-Axle Housing	90 N.m (65 ft-lbs)
Fender-to-Step	30 N.m (22 ft-lbs)
Step-to-Transmission Case	50 N.m (36 ft-lbs)
Axle Housing-to-Transmission Case	50 N.m (36 ft-lbs)
Drag Link-to-Pitman Arm	50 N.m (36 ft-lbs)
Clutch Housing-to-Transmission Case	120-150 N.m (87-108 ft-lbs)
Clutch Housing-to-Engine	90 N.m (65 ft-lbs)
Side Frames-to-Engine	90 N.m (65 ft-lbs)
Hydraulic Lines-to-Pump	8 N.m (5.8 ft-lbs)

01000 F 080181

SPECIAL TOOLS

NOTE: Order tools from your Service-Gard Catalog, unless otherwise indicated.

JDST-28 Belt Tensioning Tool is used for checking fan belt tension.

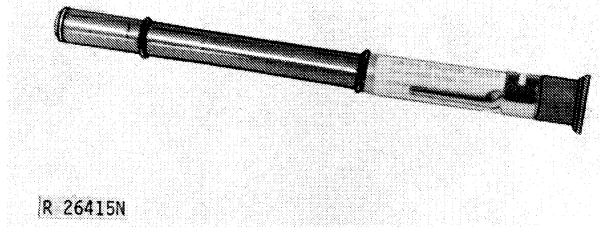

R 26415N

R26415 N 01000 G 080181

Hand Tachometer is used for checking engine speed.

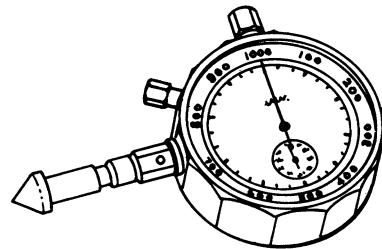

R 30607

R30607 01000 H 080181

Continued

Specifications and Special Tools

D-05104ST Radiator Tester is used for pressure testing cooling system and radiator caps.

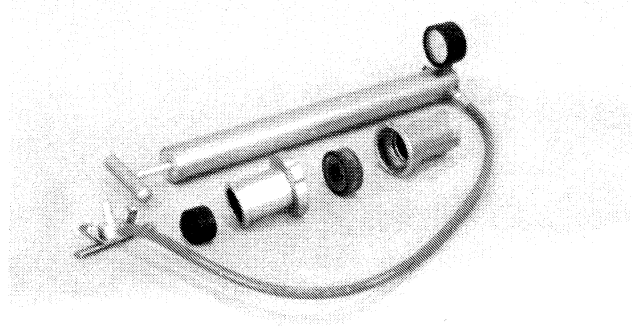

A14;T75866 U03;01000 I 260784

AR62377 Dry Element Cleaning Gun is used for cleaning air filter.

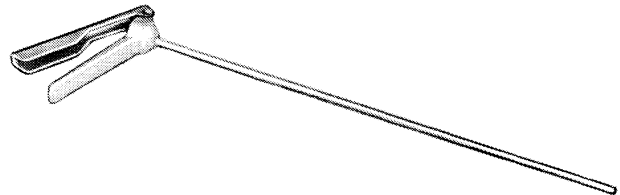

R27167N

A14;R27167 N U03;01000 J 080181

JDF-14 Timing Fixture is used for checking pump beginning of injection timing on engine.

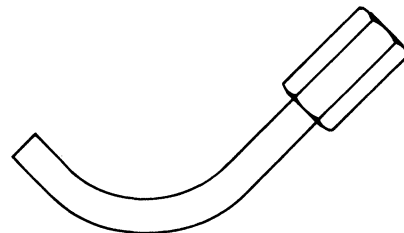

R 30234

A14;R30234 U03;01000 K 080181

INJECTION PUMP TIMING TOOL

NOTE: Two injection pump timing tools can be made from one CH18358 Injection Line.

Obtain from dealer stock:

- 1—CH18358 Injection Line
- 2—H77628 Band

Cut injection line, on straight portion of line, approximately 133 mm (5-1/4 in.) from each end. Install band (A) around injection line to prevent loss of nut.

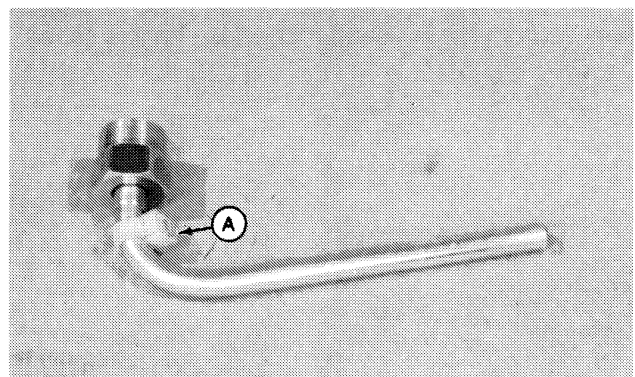

A23;RW10178 U07;23000 D 260484

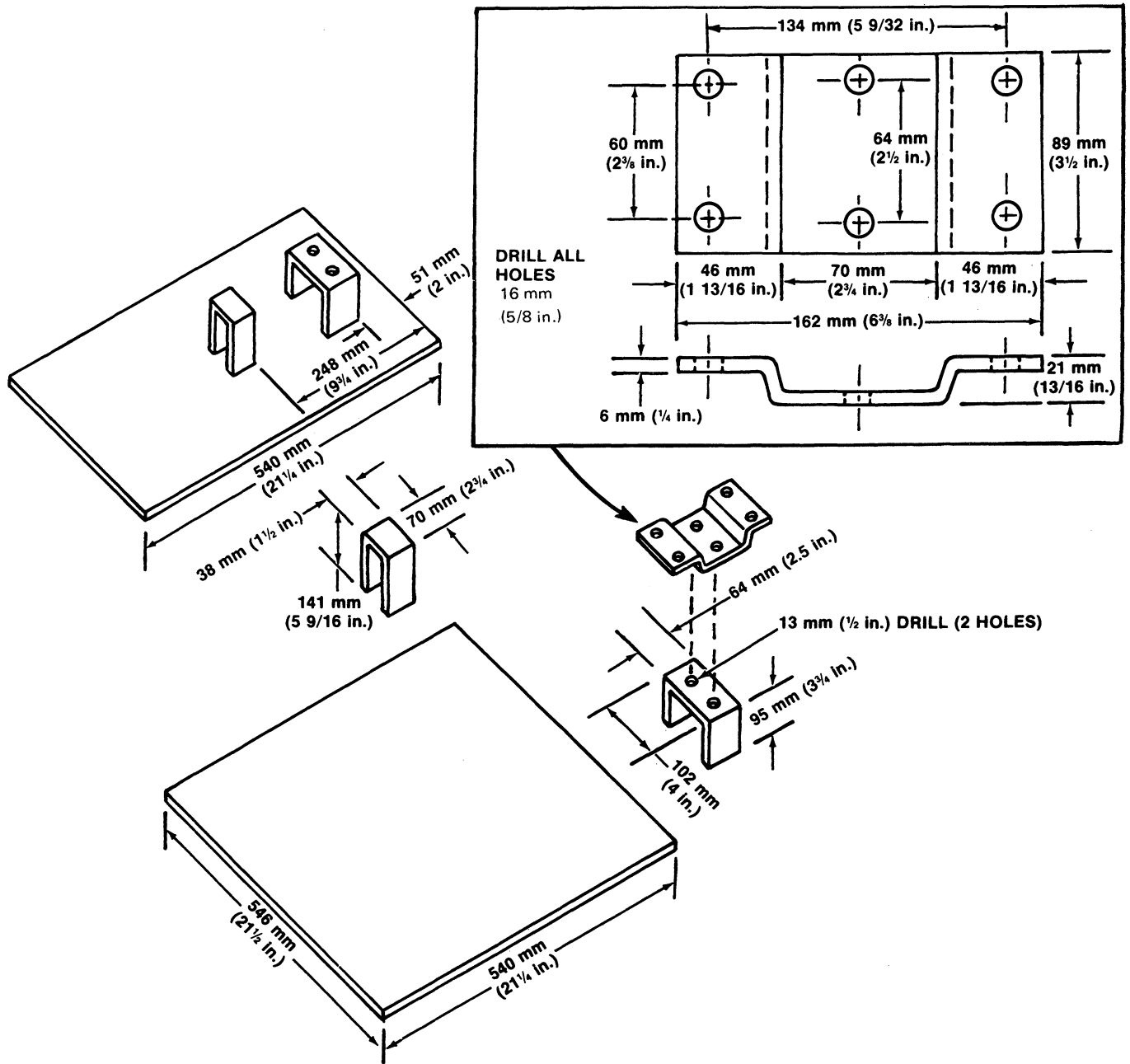

650 Transmission Disassembly Stand is used for supporting transmission and differential.

NOTE: Make sure all joints are welded properly.

Continued

RW1270 01000 L 080181

SPECIAL TOOLS—Continued

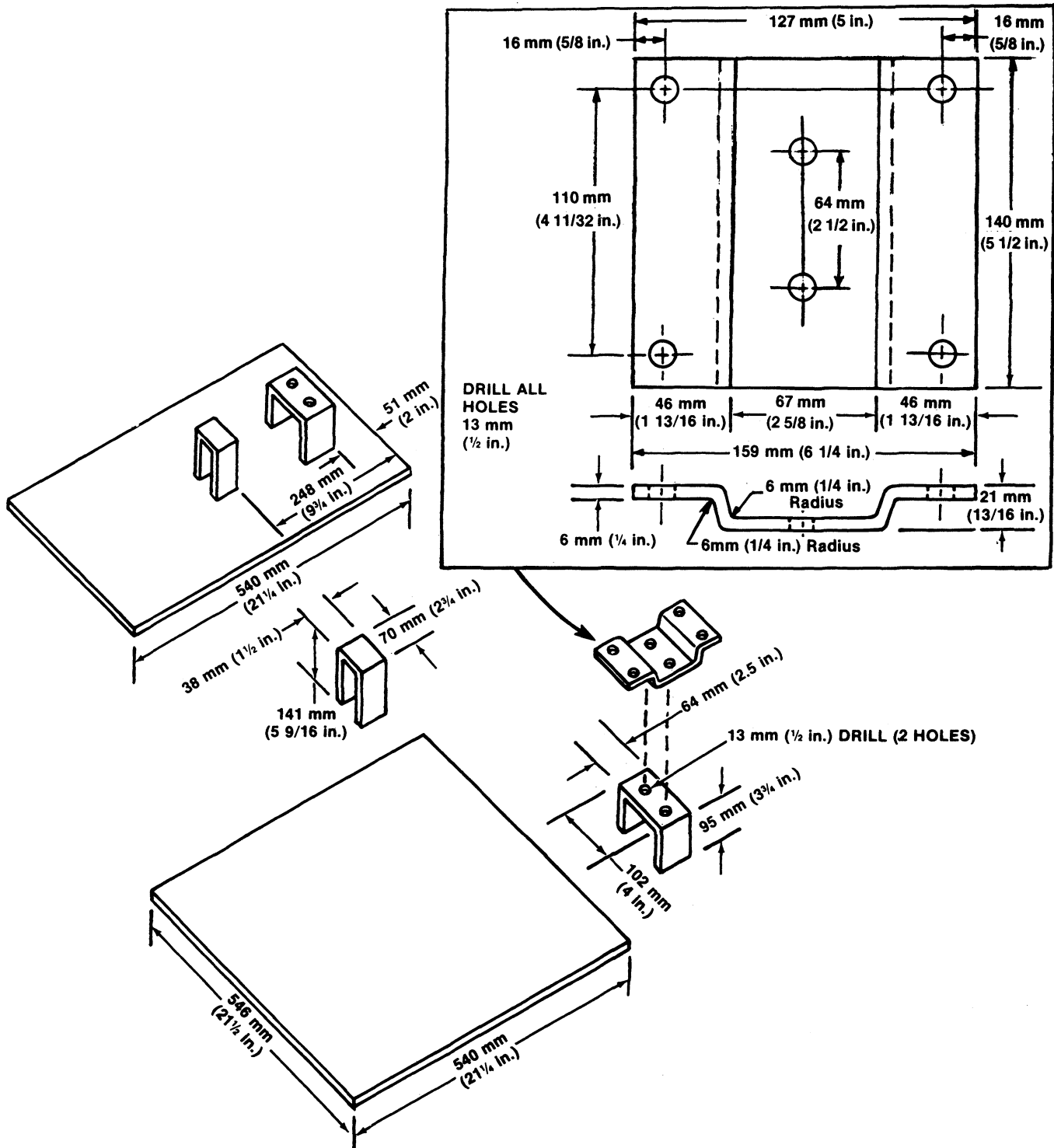

750 Transmission Disassembly Stand is used for supporting transmission and differential cases.

NOTE: Make sure all joints are welded properly.

RW1608 01000 M 080181

PREDELIVERY, DELIVERY AND AFTER-SALE SERVICES**PREDELIVERY SERVICE - GENERAL INFORMATION**

The John Deere delivery receipt, when properly filled out and signed by the dealer and customer, verifies that predelivery and delivery services were satisfactorily performed. When delivering the tractor, give the customer his copy of the delivery receipt and operators manual. Be sure to explain their purposes to him.

Because of the shipping factors involved, plus extra finishing touches necessary to promote customer satisfaction, there are certain predelivery services that must be performed by the dealer. These services are listed in the first of two sections on the predelivery form which is attached to the tractor. The second section is a list of factory inspections that must be verified by the dealer.

Fill the form in completely and sign it. Send a copy to the factory and file the original with the shop order for the job. This will certify that the proper predelivery service has been completed.

DEALER PREDELIVERY SERVICE

Using the following illustrated procedures, perform all services listed and check each job off as it is completed.

A14 U03;01005 A 111280

LUBRICATE GREASE FITTINGS

1. Lubricate drag link ends (A) with several shots of grease.

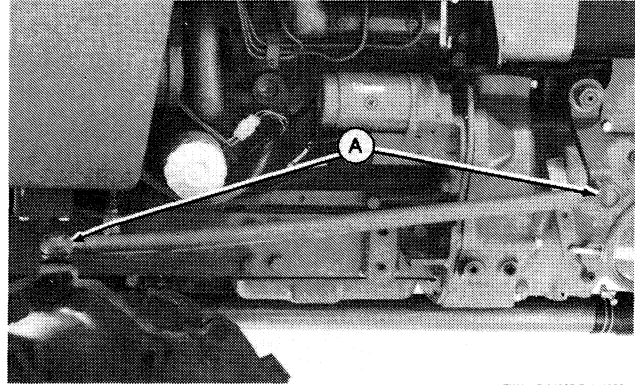

RW1117 01005 B 111280

2. Lubricate front axle pivot pin (A) on tractors without front-wheel drive, with several shots of grease.

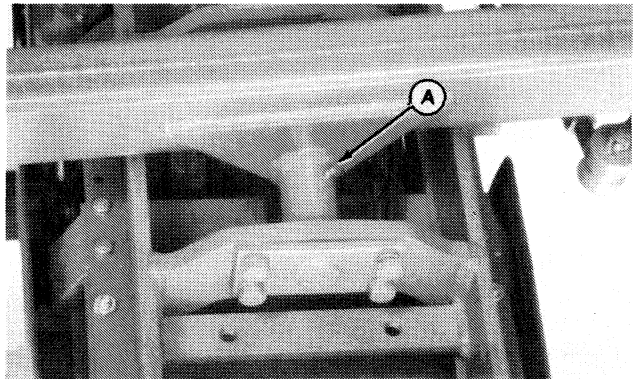

RW1110 01005 C 111280

3. Lubricate tie rod ends (A) with several shots of grease.

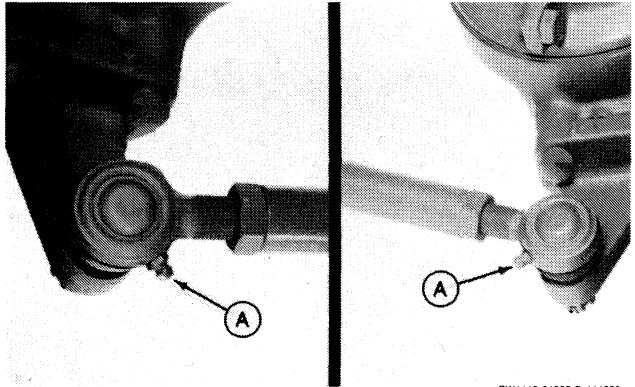

RW1113 01005 D 111280

4. Lubricate right-hand hitch lift link (A) with several shots of grease.

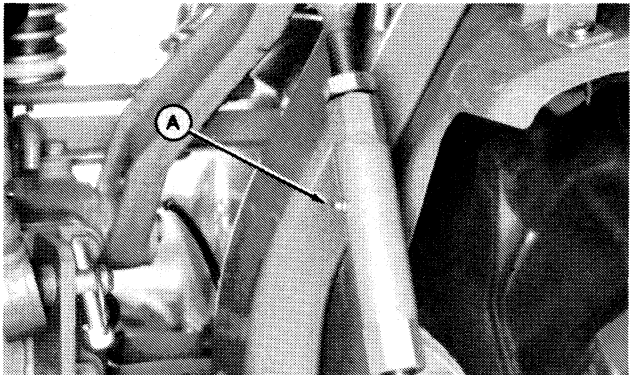

RW1107 01005 E 111280

5. Lubricate clutch pedal (A) and brake pedal (B) with several shots of grease.

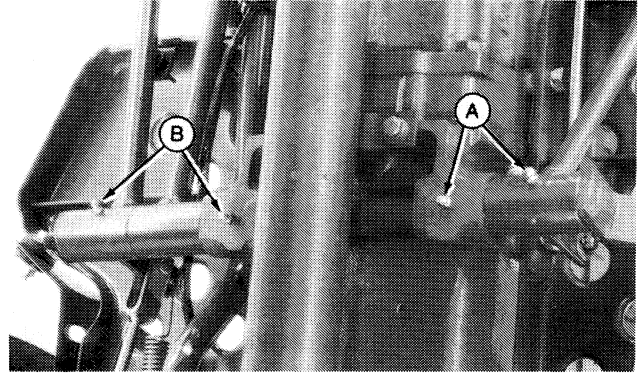

RW1115 01005 F 111280

6. Lubricate steering spindles on tractors without MFWD. Remove relief plugs (A) and apply several shots of grease to steering spindle fittings (B). Reinstall relief plugs.

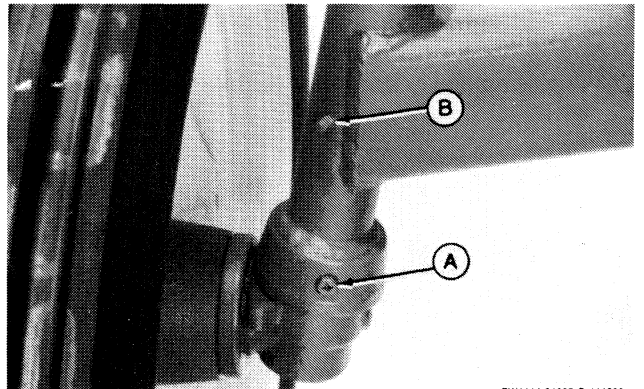

RW1114 01005 G 111280

ALIGN MUFFLER

1. Make sure muffler extension pipe is perpendicular to the tractor hood.

01005 H 111280

ADJUST ALL LAMPS

1. Check operation of lamps in all switch positions.

(A)—Turns off all lamps.

(B)—Turns on warning lamps. Use for daytime highway driving only.

(C)—Turns on bright head lamps and rear flood lamp. For field use only. Do not use on roads. Flood lamp might blind or confuse other drivers.

(D)—Turns on bright head lamps, tail lamps, and warning lamps. For highway driving during daytime or night-time.

(E)—Turns on dim head lamps, tail lamp, and warning lamps.

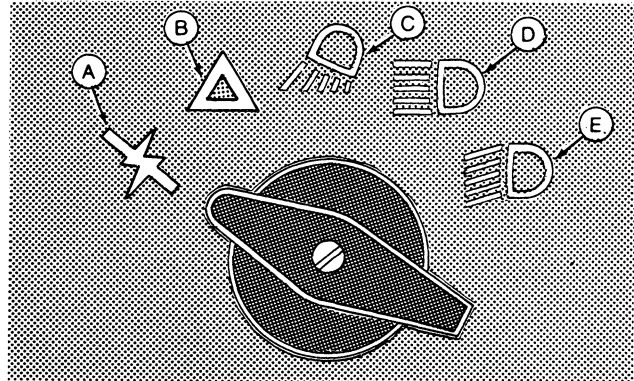

RW380 01005 I 111280

TORQUE WHEEL HARDWARE

1. Torque 650 tractor front (A) and rear (B) wheel bolts to 133 N.m (98 ft-lbs).

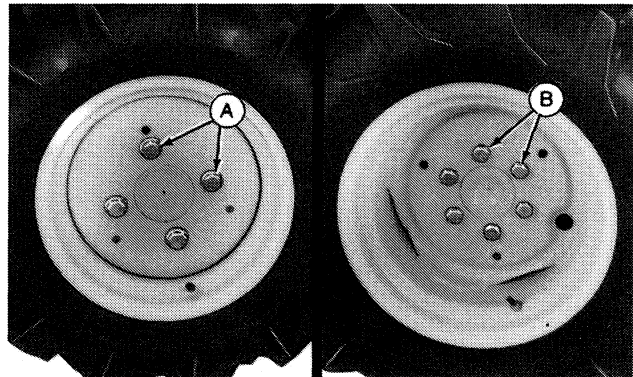

RW367 01005 J 111280

2. Torque 750 tractor wheel bolts (C) to 133 N.m (98 ft-lbs) and rear wheel bolts (D) to 186 N.m (137 ft-lbs).

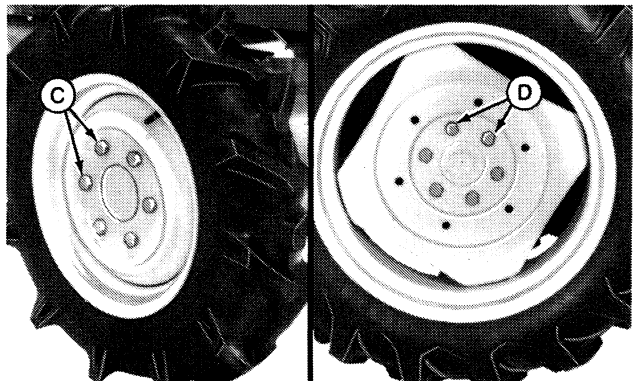

RW368 01005 K 111280

CHECK TIRE PRESSURE

Check tire pressure to be sure it is within the specifications listed in the chart.

TIRE SIZE	PLY RATING	†MINIMUM kPa (bar) (psi)	MAXIMUM kPa (bar) (psi)
Front			
5.00-12	4	140(1.4) (20)	280(2.8) (41)
6-12	4	140(1.4) (20)	200(2.0) (29)
23/8.50-12	2	70(0.7) (10)	70(0.7) (10)
6-14	4	160(1.6) (23)	200(2.0) (29)
25/8.50-14	2	70(0.7) (10)	160(1.6) (23)
4.00-15	4	250(2.5) (36)	360(3.6) (52)
Rear			
31/15.50-15	4	80(0.8) (12)	140(1.4) (20)
9.5-16	4	80(0.8) (12)	140(1.4) (20)
13.6-16	4	80(0.8) (12)	100(1.0) (14)
9.5-24	4	80(0.8) (12)	140(1.4) (20)

WT08G 01005 L 111280

ADJUST WHEEL SPACING - FRONT TREAD

Width in chart for tractors with wheels dished in to narrowest position.

IMPORTANT: Mounting wheels with dish out to increase tread width is not recommended.

Standard Axle	650 TRACTOR		
	Tread mm (in.)	Front-wheel Drive	Tread mm (in.)
5.00-12	830 (33)	6-12	870 (34)
23/8.50-12	915 (36)	23/8.50-12	985 (39)
Standard Axle	750 TRACTOR		
	Tread mm (in.)	Front-wheel Drive	Tread mm (in.)
4.00-15	900 (35)	6-14	922 (36)
25/8.50-14	934 (37)	25/8.50-14	1014 (40)

WT02G 01005 M 111280

ADJUST WHEEL SPACING - REAR TREAD

1. Wheels with regular tires should be mounted in wide tread position whenever possible. If necessary, wheels can be mounted in narrow tread position.

2. Wheels with turf tires should be mounted only with wheels dished out to wide tread position.

3. Tread width dimensions are shown in chart. Tread width is measured between centers of tires.

Tire Size	REAR TREAD WIDTH	
	Wide Tread mm (in.)	Narrow Tread mm (in.)
31/15.50-15 (Turf)	950 (37)	DO NOT USE
9.5-16	900 (35)	800 (32)
13.6-16 (Turf)	1020 (40)	DO NOT USE
9.5-24	1000 (39)	900 (35)

WT06G 01005 N 111280

ADJUST FRONT WHEEL TOE-IN

NOTE: Check toe-in before making any adjustments.

1. Steer front wheels straight ahead.
2. Measure distance between tires at hub level (A). Mark the point at which you measured.
3. Move tractor back about one meter (3 ft.), so mark is at hub level behind the axle. Again measure distance between tires at same point on tire. Tires should be 3 to 9 mm (1/8 to 3/8 in.) closer at front.

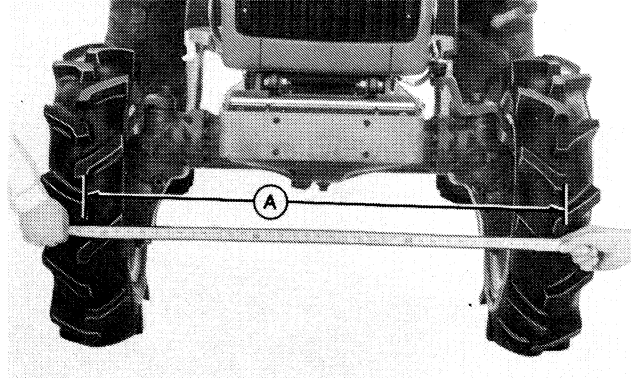

RW369 01005 Q 111280

ADJUST 650 TRACTOR TOE-IN

Loosen lock nuts (A).

2. Change tie rod length to adjust toe-in. Rotate turnbuckle clockwise (B) to shorten tie rod. Rotate counterclockwise (C) to lengthen tie rod. Adjust toe-in to 6 mm (1/4 in.).

3. Retighten lock nuts.

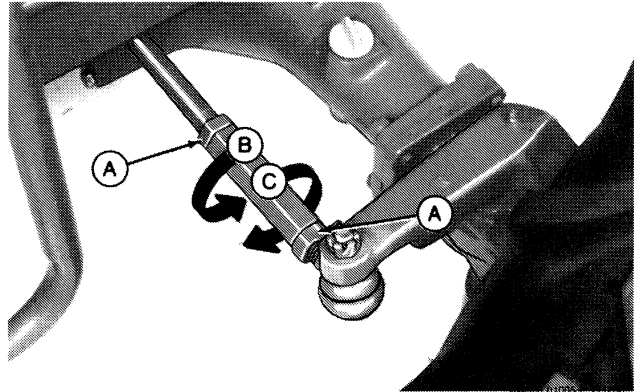

RW370 01005 Q 111280

ADJUST 750 TRACTOR TOE-IN

Loosen lock nuts at each end of tie rod (A).

2. Change tie rod length to adjust toe-in. Rotate tie rod clockwise (B) to shorten it. Rotate counterclockwise (C) to lengthen it. Adjust toe-in to 6 mm (1/4 in.).

3. Retighten lock nuts.

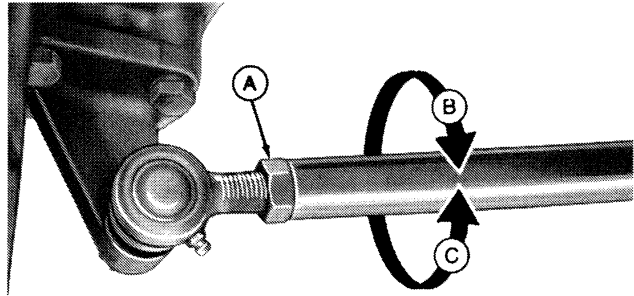

RW371 01005 Q 111280

ENGINE BREAK-IN

Follow procedure for engine break-in as instructed in Section 220, Group 10.

01005 R 111280

VERIFY PREDELIVERY SERVICE

The second part of the predelivery form is a list of factory inspections that should be verified by the dealer. Use this part of the predelivery form along with the following illustrated procedures to check and verify each item on the list.

01005 S 111280

1. Check the engine oil level. Wipe dipstick (A) off and reinsert it fully. Bring level to full mark by adding oil through filler (B) in valve cover. 650 tractor capacity is 2.5 L (2.6 U.S. qts.) including filter; 750 tractor capacity is 4.0 L (4.2 U.S. qts.) including filter.

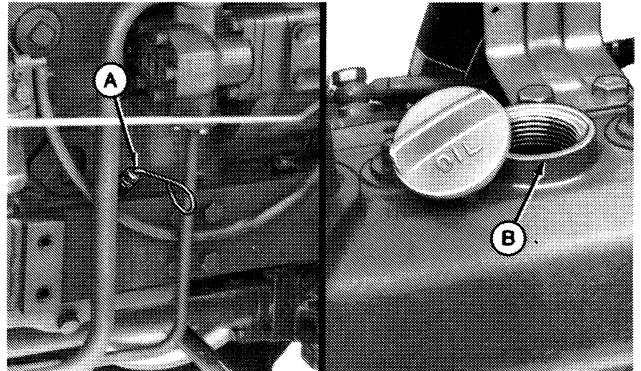

RW226 01005 T 111280

2. Check belt tension with engine stopped, press belt midway between pulleys (A). Belt should deflect 13 mm (1/2 in.) with a 98 N (22 lbs) force.

IMPORTANT: Belt must be cool when tension is checked.

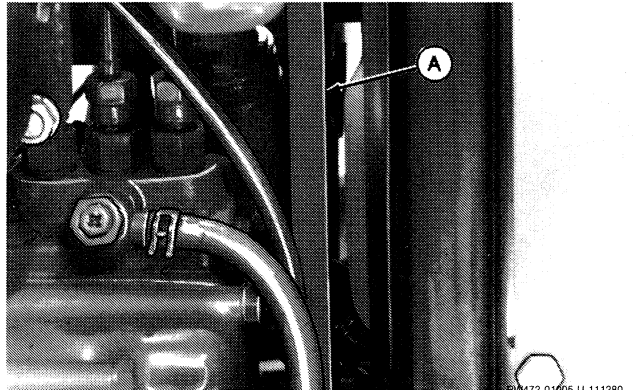

RW472 01005 U 111280

3. Remove air cleaner cover and check installation of air cleaner element (A).

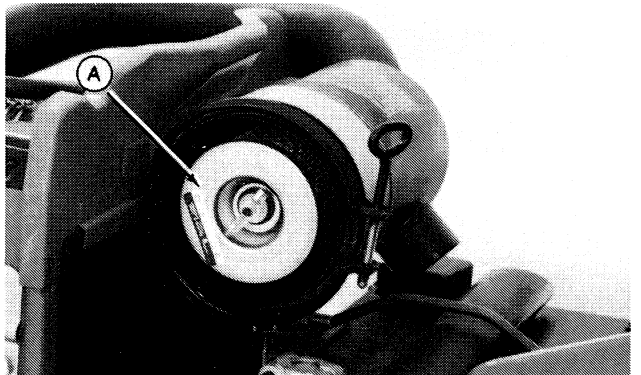

Continued

RW1116 01005 V 111280

VERIFY PREDELIVERY SERVICE—Continued

4. Check coolant level in recovery tank (A). If engine is cool and level is below "LOW" add coolant to recovery tank to bring level to "FULL". 650 tractor capacity is 3.5 L (3.7 U.S. qts.); 750 tractor is 4.2 L (4.4 U.S. qts.).

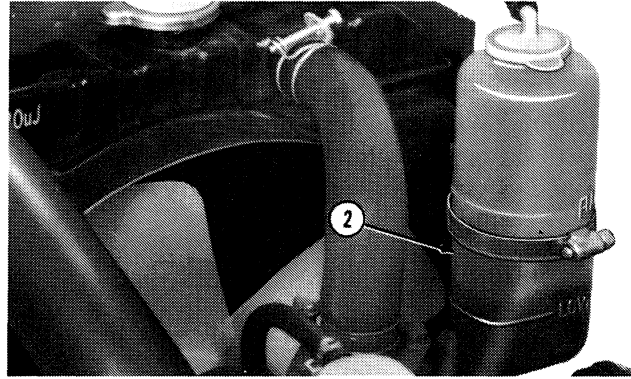

RW227 01005 W 111280

5. Check transmission-hydraulic system oil level. Remove dipstick (A) and wipe it clean. Insert dipstick to rest on threads, but do not screw it in. Oil level should be between full mark and end of dipstick. If low add enough JOHN DEERE HY-GARD Transmission and Hydraulic Oil or equivalent to bring level to the full mark.

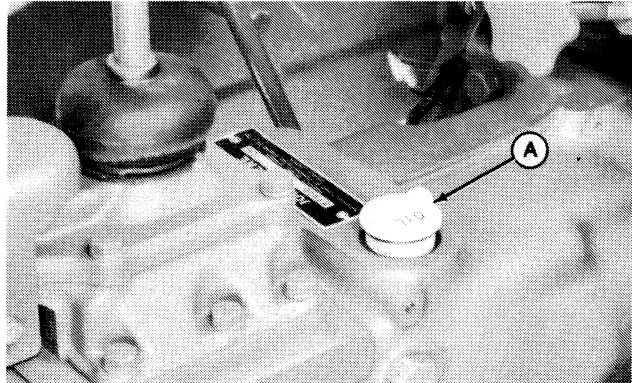

RW1112 01005 X 111280

6. Check front axle oil level on MFWD equipped tractors. Remove dipstick (A) and wipe it clean. Insert dipstick to rest on threads, but do not screw it in. Oil level should be between full mark and end of dipstick. If low add enough John Deere SAE 90 Gear Lubricant or an equivalent to bring level to the full mark.

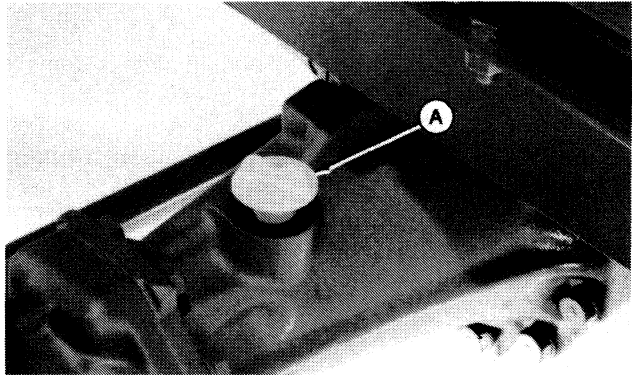

RW1118 01005 Y 121280

7. Check installation of safety shields, handrails and steps. Be sure mounting hardware is tight.

8. Check installation of ROLL-GARD Protective Structure. Be sure mounting hardware is tight.

01005 Z 121280

9. To check battery condition, use a battery hydrometer (A). Check specific gravity of electrolyte in each cell. Charge battery if reading is below 1.215. Replace battery if difference between cells is more than 0.050.

Always correct specific gravity reading for electrolyte temperature variation. Add 0.007 for every 10°C above 27°C. (Add 0.004 for every 10°F above 80°F). Subtract at same rate if electrolyte temperature is below 27°C (80°F). Corrected specific gravity of a fully charged battery is 1.260.

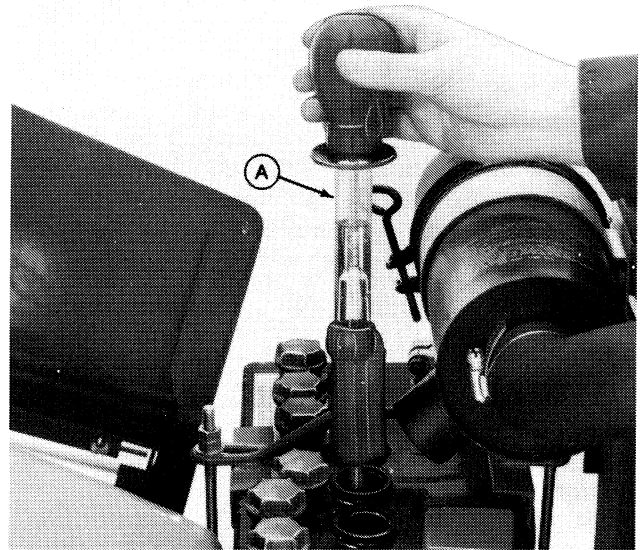

RW491 01005 AA 121280

10. Tractor light switch has five position:

(A)—Turns off all lamps.

(B)—Turns on warning lamps only. For driving on highway during daytime.

(C)—Turns on bright head lamps and rear flood lamp. For field use only. Do not use on roads. Flood lamp might blind or confuse other drivers.

(D)—Turns on bright head lamps, tail lamps, and warning lamps. For highway driving during daytime or night-time.

(E)—Turns on dim head lamps, tail lamp, and warning lamps.

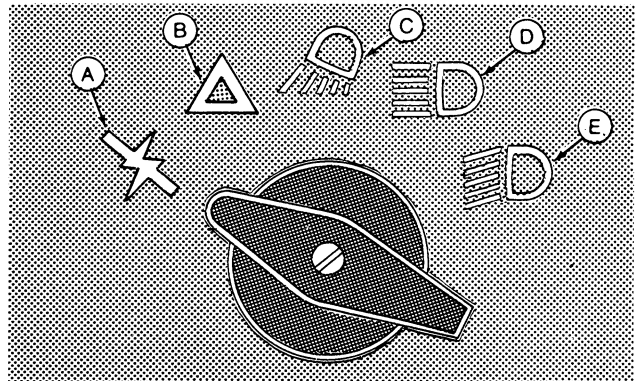

Continued

RW380 01005 AB 121280

VERIFY PREDELIVERY SERVICE—Continued

11. Check operation of neutral start switch. Engine should not turn over unless shift lever is in neutral position.

12. Check operation of Thermo-Start. Turn key switch (A) counterclockwise and hold it there 10 or 15 seconds. An electric glow plug (B) ignites a small amount of fuel in the intake manifold. Quickly turn key switch clockwise and start engine.

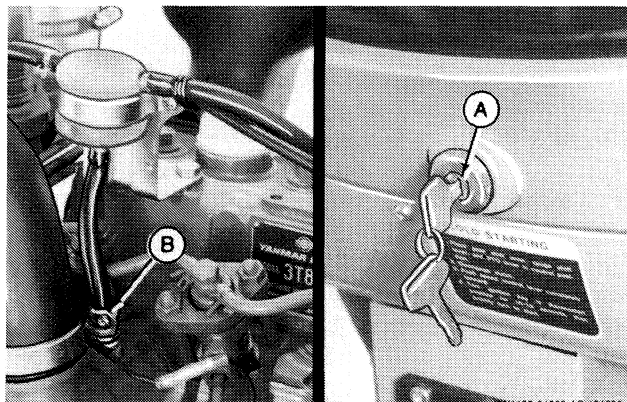

RW1108 01005 AC 121280

13. Check clutch pedal adjustment as instructed in the following procedure:

Measure free travel at top of pedal stroke (A). If 650 tractor free travel is 10 mm (3/8 in.) or less, adjust linkage to obtain 16 mm (5/8 in.) travel. If 750 tractor is 16 mm (5/8 in.) or less, adjust linkage to obtain 22 mm (7/8 in.) travel.

To adjust linkage, loosen lock nuts (B) and rotate turn-buckle (C). Recheck travel and retighten lock nuts.

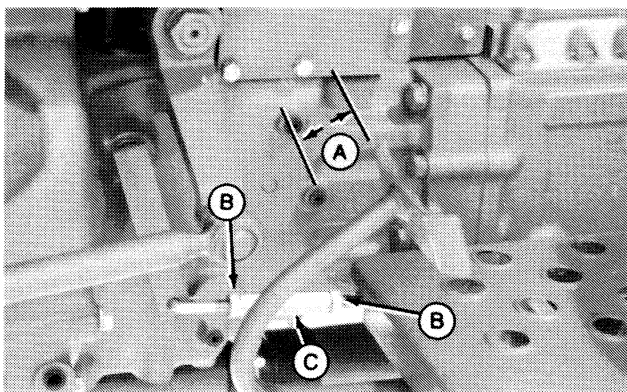

RW1111 01005 AD 121280

14. Check engine slow and fast idle speeds. Slow idle speed should be 800 rpm (A).

Full throttle speed at full load should be 2600 rpm (B) for the 650 tractor and 2400 rpm (C) for the 750 tractor. Use tachometer on dash for checking slow and fast idle speeds.

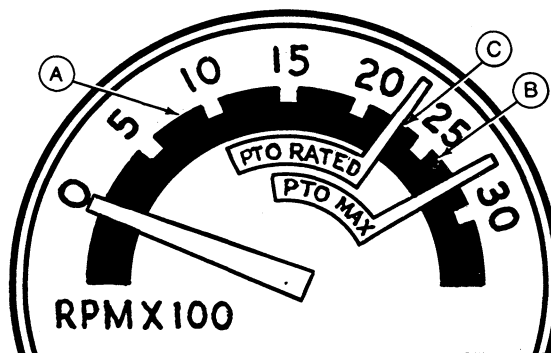

RW244 01005 AF 121280

15. Check operation of full turn steering.

16. Check operation of brakes—Check with engine running and stopped.

17. Check transmission operation: Operate in all gears. If any problem is found, refer to Section 250.

01005 AF 121280

18. Check operation of differential lock. Differential lock may be engaged by foot pedal (A). Differential lock cannot be engaged on-the-go. Unequal traction will keep the lock engaged. When traction equalizes, lock will disengage itself by spring action. If lock does not disengage, depress one brake pedal and then the other.

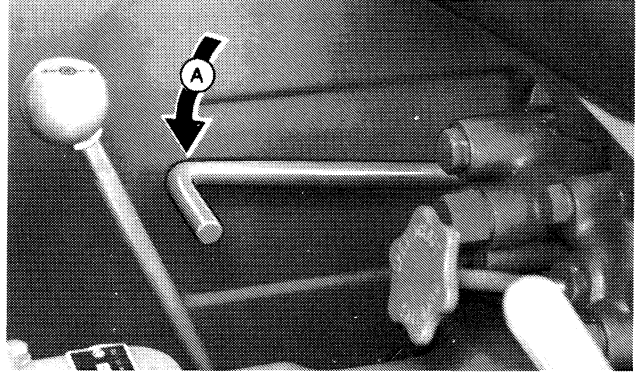

RW257 01005 AG 121280

19. Check operation of rockshaft. Rockshaft should raise and lower smoothly. Pull rockshaft control lever (A) rearward to raise rockshaft and push lever (B) forward to lower it.

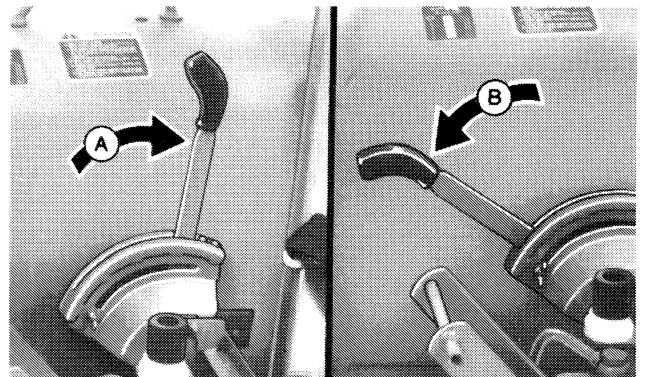

RW265 01005 AH 121280

20. Check operation of Selective Control Valve. Install remote cylinder. Pull SCV lever slightly to rear of neutral (A) and hold it against spring pressure. This extends cylinder (B) and in most cases raises implement. Lever returns to neutral when released.

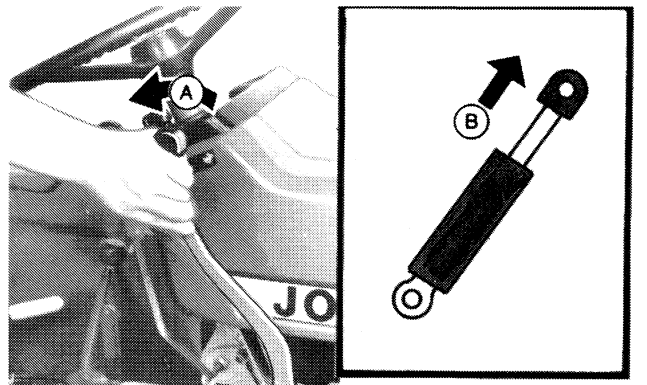

RW285 01005 AI 121280

21. Check PTO operation. With transmission in neutral and engine running, depress clutch fully and engage PTO by pushing control lever down (A). Pull control lever up to disengage PTO (B).

22. Check operation of neutral-start switch. Place shift lever and range shift lever in neutral positions. Tractor will start if PTO lever is in the disengaged position.

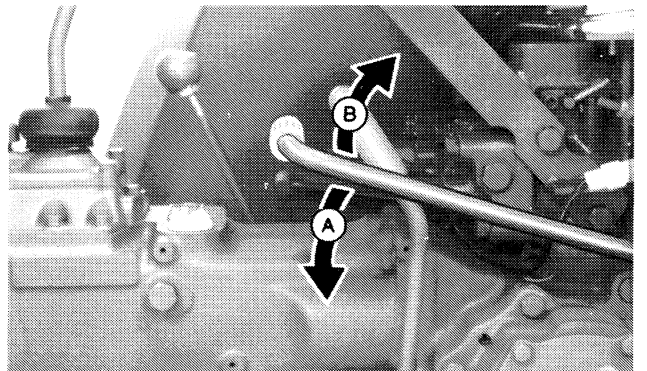

RW302 01005 AJ 121280

Continued

VERIFY PREDELIVERY SERVICE—Continued

23. Check installation of seat belts. Be sure mounting hardware is tight.

24. Check for any signs of leakage in oil lines.

25. Check for any signs of leakage in fuel lines. Tighten connections as necessary.

26. Check paint and decals. Be sure all decals are smooth and neat. Check for overspray on decals.

Clean and touch up tractor as necessary.

01005 AK 121280

DELIVERY SERVICE

A thorough discussion of the operation and service of a new tractor at the time of delivery helps to assure complete customer satisfaction. Proper delivery should be an important phase of a dealer's program. A portion of the John Deere Delivery Receipt emphasizes the importance of proper delivery service.

Many complaints have arisen simply because the owner was not shown how to operate and service his new tractor properly. Enough time should be devoted, at the customer's convenience, to introducing the owner to his new tractor and explaining to him how to operate and service it.

The following procedure is recommended before the serviceman and owner complete the delivery acknowledgments portion of the delivery receipt.

01005 AL 121280

Using the tractor operator's manual as a guide, be sure the owner understands these points thoroughly:

1. Controls and instruments.
2. How to start and stop the engine.
3. The importance of the break-in period.
4. How to use liquid or cast-iron ballast.
5. All functions of the hydraulic system.
6. Using the power takeoff.
7. The importance of safety.
8. The importance of lubrication and periodic services.

Give particular emphasis to rockshaft speed-of-drop, rockshaft selector lever (load and depth control), engine oil pressure indicator light, coolant temperature indicator light, and charging system indicator light. These areas are very often misunderstood.

After explaining and demonstrating the above features, have the owner sign the delivery receipt and give him the operator's manual.

01005 AM 121280

AFTER-SALE INSPECTION

The purchaser of a new John Deere tractor is entitled to a free inspection within the warranty period after the equipment has been "run-in". The terms of this after-sale inspection are outlined on the back of the John Deere Delivery Receipt.

The purpose of this inspection is to make sure that the customer is receiving satisfactory performance from his tractor. At the same time, the inspection should reveal whether the tractor is being operated, lubricated, and serviced properly.

If the recommended after-sale service inspection is followed, the dealer can eliminate a needless volume of service work by preventing minor irregularities from developing into serious problems later on. This will promote strong dealer-customer relations and present the dealer and opportunity to answer questions that may have arisen during the first few days of operation.

Continued

01005 AM 121280

AFTER-SALE INSPECTION—Continued

The following inspection program is recommended within the first 100 hours of tractor operation.

01005 AO 121280

ENGINE

1. Check for signs of leakage in fuel and oil lines.
2. Check all hoses and connections for leaks in cooling system. Correct as necessary.

IMPORTANT: Belt must be cool when tension is checked.

3. Check fan belt (A) tension and adjust as necessary. Belt should deflect 13 mm (1/2 in.) with a 98 N (22 lbs.) force.

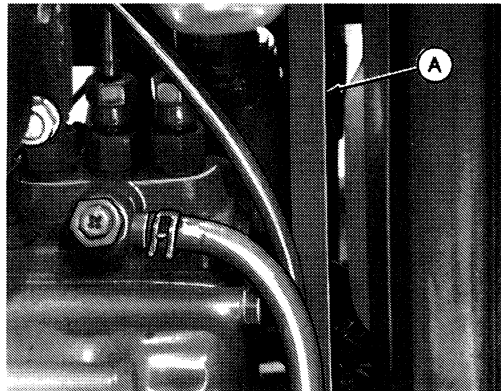

RW472 01005 AP 121280

4. Check engine slow and fast idle speeds. With no load, 650 tractor fast idle speed should be 2725 rpm. 750 tractor no load fast idle speed should be 2550 rpm. Slow idle speed for either tractor is 800 rpm.

5. Check operation of hand throttle (A) stop position. Be sure engine stops immediately after hand throttle is pulled all the way to the rear.

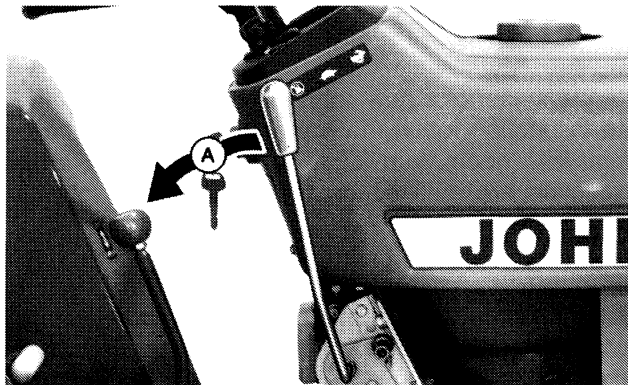

RW297 01005 AQ 121280

ELECTRICAL

1. Check operation of neutral start switches. Engine should not turn over unless gear shift lever (A) and range shift lever (B) are in neutral position and PTO lever (C) is in disengaged position.

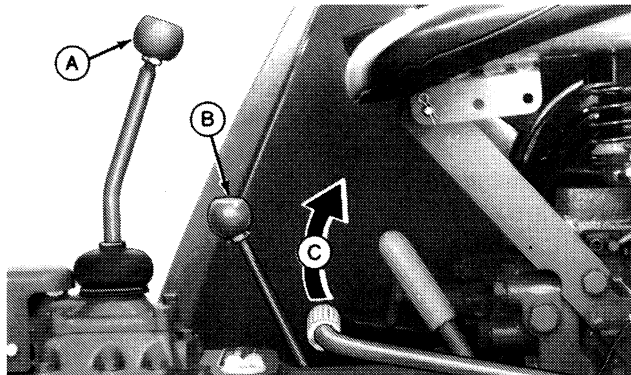

RW231 01005 AR 121280

2. Check operation of all lights.

(A)-Turns off all lamps.

(B)-Turns on warning lamps only.

(C)-Turns on bright head lamps and rear flood lamp.

(D)-Turns on bright head lamps, tail lamp, and warning lamps.

(E)-Turns on dim head lamps, tail lamp, and warning lamps.

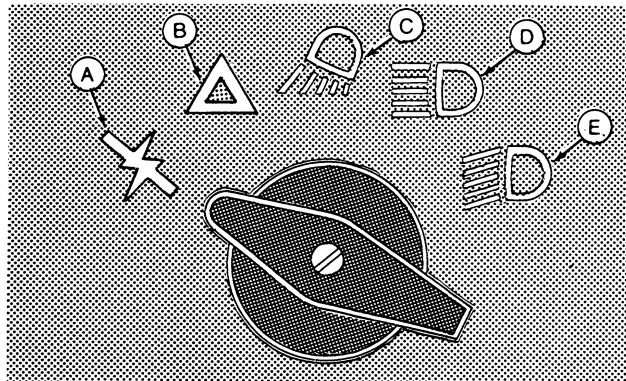

3. Check specific gravity of battery. Use a battery hydrometer (A). Corrected specific gravity of a fully charged battery is 1.260. Add 0.007 for every 10°C above 27°C. (Add 0.004 for every 10°F above 80°F). Subtract at same rate if electrolyte temperature is below 27°C (80°F).

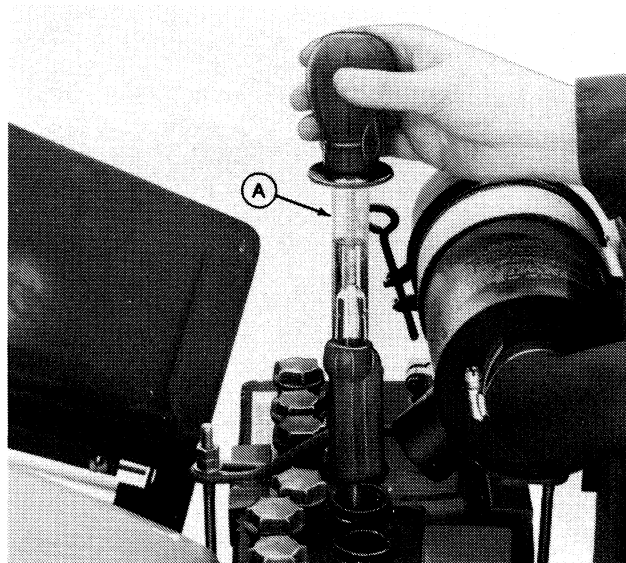

POWER TRAIN

1. Check operation of transmission. Range shift lever (A) provides two speed ranges. Low range speeds are generally below 4 km/h (2.5 mph), and high range speeds are above. Gear shift lever (B) provides four forward speeds and reverse in each range. Be sure transmission operates smoothly in all gears.

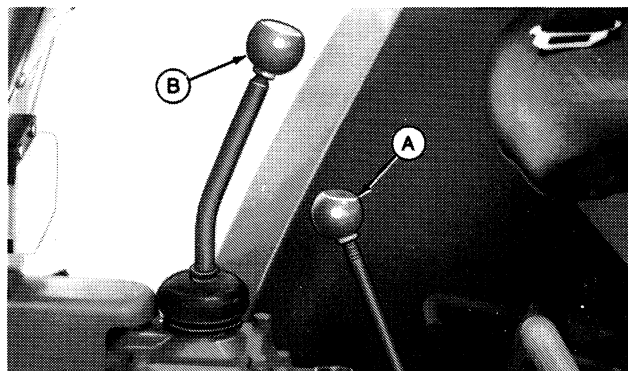

2. Check operation of differential lock. When one wheel starts to spin, engage differential lock by depressing pedal (A). When traction equalizes, lock will disengage itself by spring action.

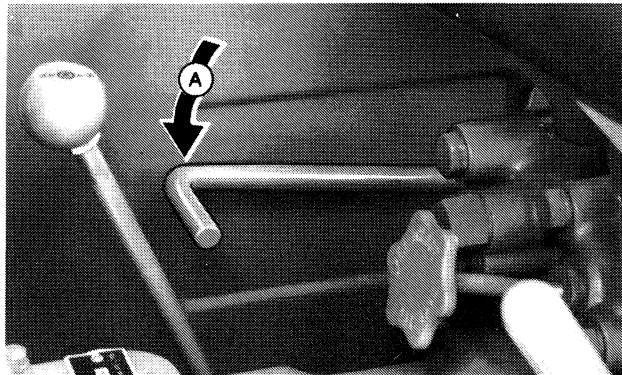

Continued

RW257 01005 AV 121280

POWER TRAIN—Continued

3. Check PTO operation and be sure master shield is in place. Push control lever down to engage PTO (A). Pull Control lever up to disengage PTO (B).

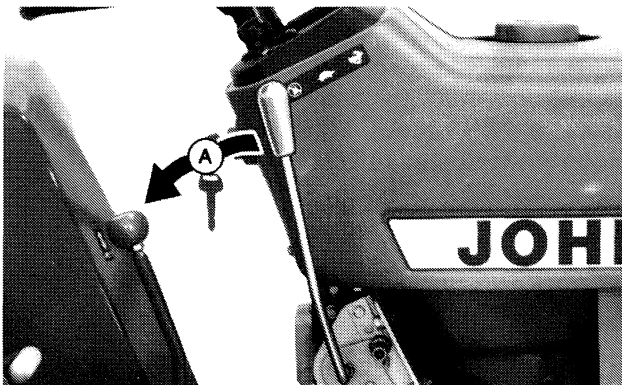

RW297 01005 AW 121280

HYDRAULICS

1. Check operation of rockshaft. To raise rockshaft, pull rockshaft control lever rearward (A) and to lower rockshaft, push lever forward (B).

2. Check hydraulic lines and connections for any leaks.

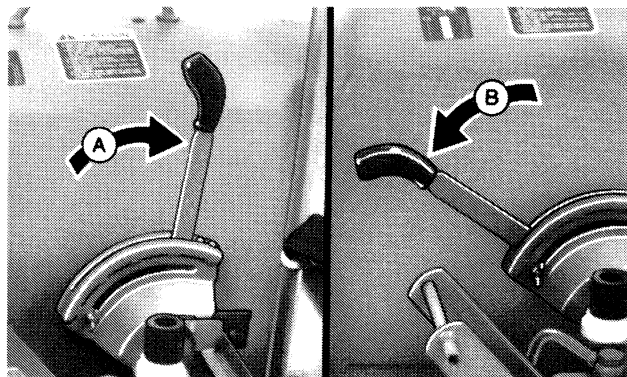

RW265 01005 AX 121280

STEERING/BRAKES

1. Check operation of brakes. Check with engine running and with engine stopped.

2. Check steering operation. Be sure steering operates smoothly in both directions.

01005 AY 121280