

Product: John Deere L1642, L17.542, L2048 and L2548 Scotts Lawn Tractor Service Repair Technical Manual
Full Download: <https://www.bobmanualstore.com/downloads/john-deere-l1642-l17-542-l2048-and-l2548-scotts-lawn-tractor-service-repair-technical-manual/>

**Scotts Lawn Tractor
L1642, L17.542, L2048 and L2548**

TM1949 JAN02

TECHNICAL MANUAL



***Manufactured
by John Deere***



JOHN DEERE

North American Version
Litho in U.S.A.

Sample manual. Download All 334 pages at:

<https://www.bobmanualstore.com/downloads/john-deere-l1642-l17-542-l2048-and-l2548-scotts-lawn-tractor-service-repair-technical-manual/>

Product: John Deere L1642, L17.542, L2048 and L2548 Scotts Lawn Tractor Service Repair Technical Manual
Full Download: <https://www.bobmanualstore.com/downloads/john-deere-l1642-l17-542-l2048-and-l2548-scotts-lawn-tractor-service-repair-technical-manual/>

Sample manual. Download All 334 pages at:

<https://www.bobmanualstore.com/downloads/john-deere-l1642-l17-542-l2048-and-l2548-scotts-lawn-tractor-service-repair-technical-manual/>

INTRODUCTION

Manual Description

This technical manual is written for an experienced technician and contains sections that are specifically for this product. It is a part of a total product support program.

The manual is organized so that all the information on a particular system is kept together. The order of grouping is as follows:

Table of Contents

General Diagnostic Information

Specifications

Electrical Wiring Harness Legend

Component Location

System Schematic

Wiring Harness

Troubleshooting Chart

Theory of Operation

Diagnostics

Tests & Adjustments

Repair

Depending on the particular section or system being covered, not all of the above groups may be used.

Each section will be identified with a symbol rather than a number. The groups and pages within a section will be consecutively numbered.

We appreciate your input on this manual. To help, there are postage paid post cards included at the back. If you find any errors or want to comment on the layout of the manual please fill out one of the cards and mail it back to us.

Safety

Specifications and Information

Engine - Briggs & Stratton (Single)

Engine - Briggs & Stratton (Twin)

Engine - Kohler

Electrical

Power Train - Gear Transmission

Power Train - Hydro Transmission

Steering

Brakes

Attachments

Miscellaneous

All information, illustrations and specifications in this manual are based on the latest information at the time of publication. The right is reserved to make changes at any time without notice.

COPYRIGHT© 2002
Deere & Co.

John Deere Worldwide Commercial and
Consumer Equipment Division
All rights reserved
Previous Editions
COPYRIGHT©

SAFETY

Recognize Safety Information

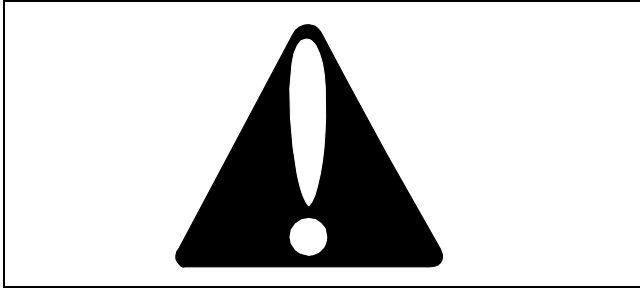

This is the safety-alert symbol. When you see this symbol on your machine or in this manual, be alert to the potential for personal injury.

Follow recommended precautions and safe servicing practices.

Understand Signal Words

A signal word—DANGER, WARNING, or CAUTION—is used with the safety-alert symbol. DANGER identifies the most serious hazards.

DANGER or WARNING safety signs are located near specific hazards. General precautions are listed on CAUTION safety signs. CAUTION also calls attention to safety messages in this manual.

Replace Safety Signs

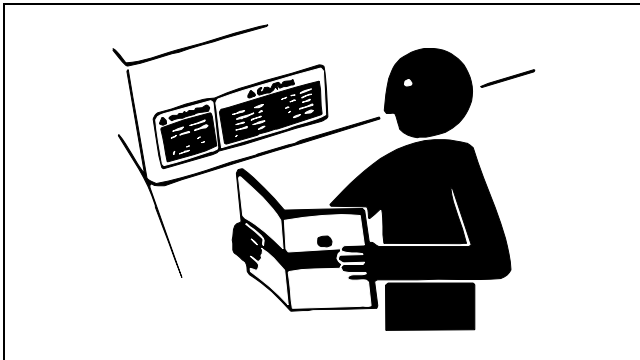

Replace missing or damaged safety signs. See the machine operator's manual for correct safety sign placement.

Be Prepared For Emergencies

- When you work around fuel, do not smoke or work near heaters or other fire hazards.
- Store flammable fluids away from fire hazards. Do not incinerate or puncture pressurized containers.

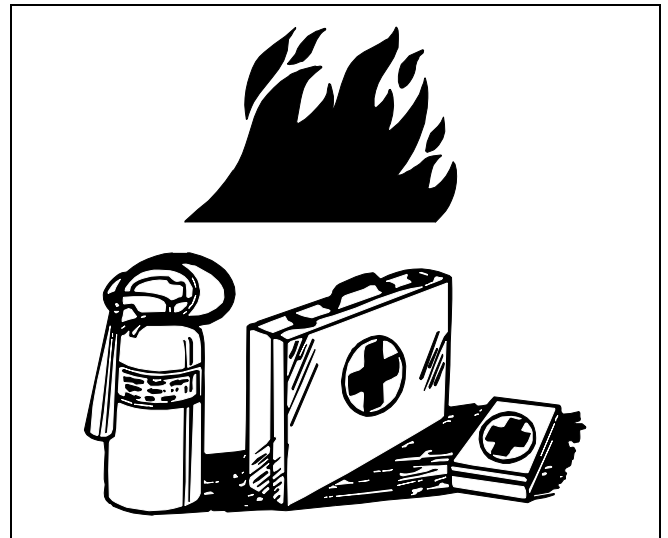

- Make sure machine is clean of trash, grease, and debris.
- Do not store oily rags; they can ignite and burn spontaneously.
- Be prepared if a fire starts.
- Keep a first aid kit and fire extinguisher handy.
- Keep emergency numbers for doctors, ambulance service, hospital, and fire department near your telephone.

Use Care In Handling And Servicing Batteries

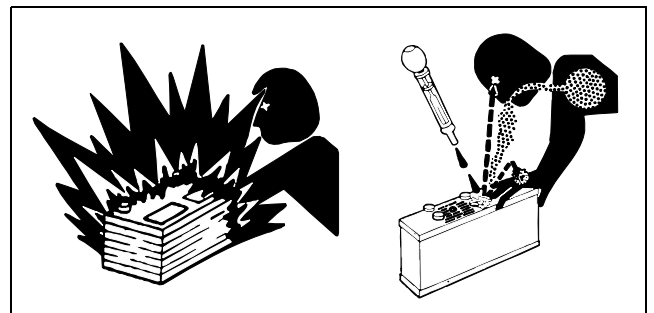

Prevent Battery Explosions

- Keep sparks, lighted matches, and open flame away from the top of battery. Battery gas can explode.
- Never check battery charge by placing a metal object across the posts. Use a volt-meter or hydrometer.
- Do not charge a frozen battery; it may explode. Warm battery to 16°C (60°F).

Prevent Acid Burns

- Sulfuric acid in battery electrolyte is poisonous. It is strong enough to burn skin, eat holes in clothing, and cause blindness if splashed into eyes.

SAFETY

Avoid acid burns by:

1. Filling batteries in a well-ventilated area.
2. Wearing eye protection and rubber gloves.
3. Avoiding breathing fumes when electrolyte is added.
4. Avoiding spilling or dripping electrolyte.
5. Use proper jump start procedure.

If you spill acid on yourself:

1. Flush your skin with water.
2. Apply baking soda or lime to help neutralize the acid.
3. Flush your eyes with water for 10_15 minutes.
4. Get medical attention immediately.

If acid is swallowed:

1. Drink large amounts of water or milk.
2. Then drink milk of magnesia, beaten eggs, or vegetable oil.
3. Get medical attention immediately.

Wear Protective Clothing

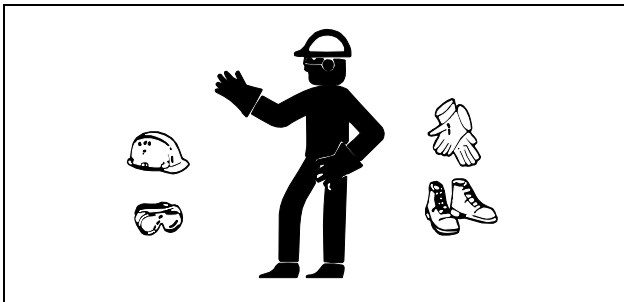

Wear close fitting clothing and safety equipment appropriate to the job.

Prolonged exposure to loud noise can cause impairment or loss of hearing. Wear a suitable hearing protective device such as earmuffs or earplugs to protect against objectionable or uncomfortable loud noises.

Operating equipment safely requires the full attention of the operator. Do not wear radio or music headphones while operating machine.

Service Machines Safely

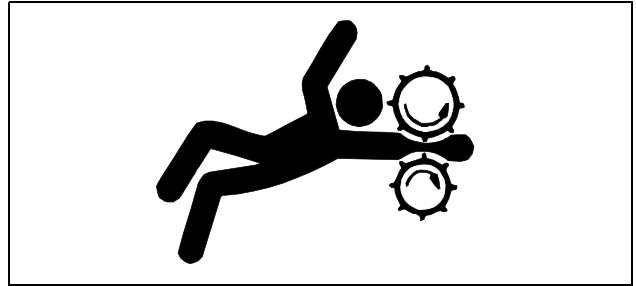

Tie long hair behind your head. Do not wear a necktie, scarf, loose clothing, or necklace when you work near machine tools or moving parts. If these items were to get caught, severe injury could result.

Remove rings and other jewelry to prevent electrical shorts and entanglement in moving parts.

Use Proper Tools

Use tools appropriate to the work. Makeshift tools and procedures can create safety hazards. Use power tools only to loosen threaded parts and fasteners. For loosening and tightening hardware, use the correct size tools. **DO NOT** use U.S. measurement tools on metric fasteners. Avoid bodily injury caused by slipping wrenches. Use only service parts meeting John Deere specifications.

Park Machine Safely

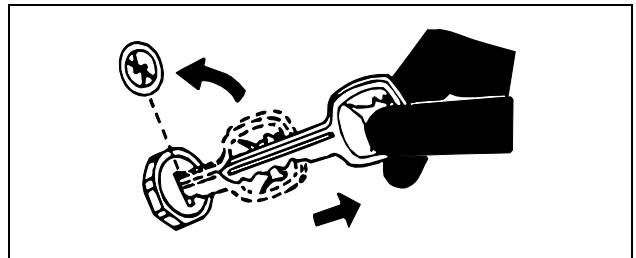

Before working on the machine:

1. Lower all equipment to the ground.
2. Stop the engine and remove the key.
3. Disconnect the battery ground strap.
4. Hang a "DO NOT OPERATE" tag in operator station.

Support Machine Properly And Use Proper Lifting Equipment

If you must work on a lifted machine or attachment, securely support the machine or attachment.

Do not support the machine on cinder blocks, hollow tiles,

SAFETY

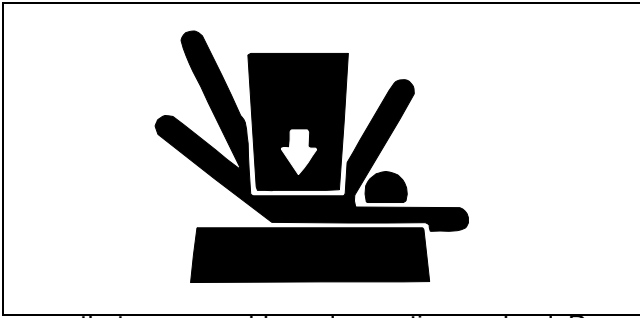

or props that may crumble under continuous load. Do not work under a machine that is supported solely by a jack. Follow recommended procedures in this manual.

Lifting heavy components incorrectly can cause severe injury or machine damage. Follow recommended procedure for removal and installation of components in the manual.

Work In Clean Area

Before starting a job:

1. Clean work area and machine.
2. Make sure you have all necessary tools to do your job.
3. Have the right parts on hand.
4. Read all instructions thoroughly; do not attempt shortcuts.

Using High Pressure Washers

Directing pressurized water at electronic/electrical components or connectors, bearings, hydraulic seals, fuel injection pumps or other sensitive parts and components may cause product malfunctions. Reduce pressure and spray at a 45 to 90 degree angle.

Illuminate Work Area Safely

Illuminate your work area adequately but safely. Use a portable safety light for working inside or under the machine. Make sure the bulb is enclosed by a wire cage. The hot filament of an accidentally broken bulb can ignite spilled fuel or oil.

Work In Ventilated Area

Engine exhaust fumes can cause sickness or death. If it is necessary to run an engine in an enclosed area, remove the exhaust fumes from the area with an exhaust pipe extension.

If you do not have an exhaust pipe extension, open the doors and get outside air into the area.

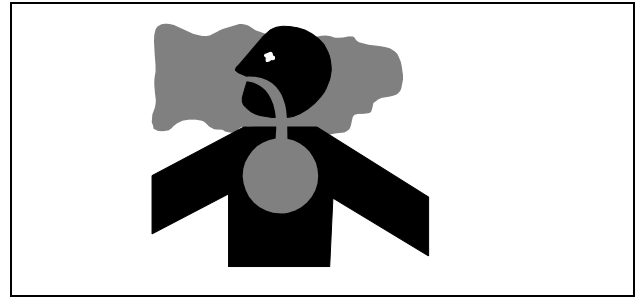

Warning: California Proposition 65 Warning

Gasoline engine exhaust from this product contains chemicals known to the State of California to cause cancer, birth defects, or other reproductive harm.

Remove Paint Before Welding Or Heating

Avoid potentially toxic fumes and dust. Hazardous fumes can be generated when paint is heated by welding, soldering, or using a torch. Do all work outside or in a well ventilated area. Dispose of paint and solvent properly. Remove paint before welding or heating: If you sand or grind paint, avoid breathing the dust. Wear an approved respirator. If you use solvent or paint stripper, remove stripper with soap and water before welding. Remove solvent or paint stripper containers and other flammable material from area. Allow fumes to disperse at least 15 minutes before welding or heating.

Avoid Harmful Asbestos Dust

Avoid breathing dust that may be generated when handling components containing asbestos fibers. Inhaled asbestos fibers may cause lung cancer.

Components in products that may contain asbestos fibers are brake pads, brake band and lining assemblies, clutch plates, and some gaskets. The asbestos used in these components is usually found in a resin or sealed in some way. Normal handling is not hazardous as long as airborne dust containing asbestos is not generated.

Avoid creating dust. Never use compressed air for cleaning. Avoid brushing or grinding material containing asbestos. When servicing, wear an approved respirator. A special vacuum cleaner is recommended to clean asbestos. If not available, apply a mist of oil or water on the material containing asbestos. Keep bystanders away from the area.

SAFETY

Service Tires Safely

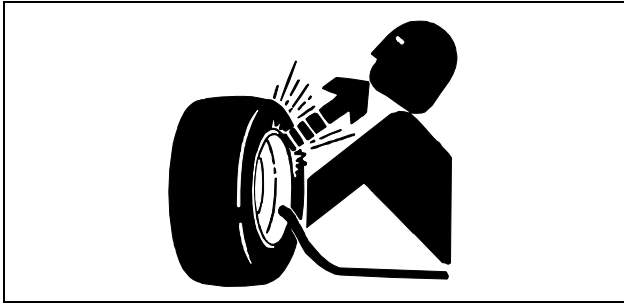

Explosive separation of a tire and rim parts can cause serious injury or death.

Do not attempt to mount a tire unless you have the proper equipment and experience to perform the job.

Always maintain the correct tire pressure. Do not inflate the tires above the recommended pressure. Never weld or heat a wheel and tire assembly. The heat can cause an increase in air pressure resulting in a tire explosion. Welding can structurally weaken or deform the wheel.

When inflating tires, use a clip-on chuck and extension hose long enough to allow you to stand to one side and NOT in front of or over the tire assembly. Use a safety cage if available.

Check wheels for low pressure, cuts, bubbles, damaged rims or missing lug bolts and nuts.

Avoid Injury From Rotating Blades, Augers And Pto Shafts

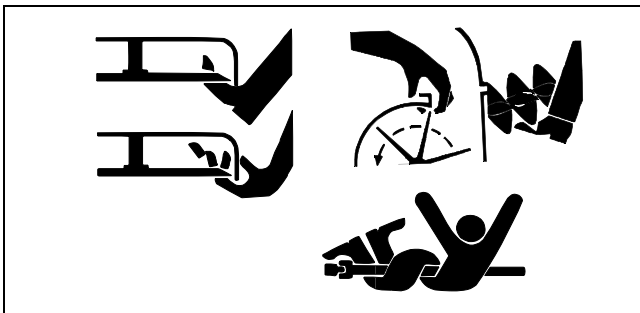

Keep hands and feet away while machine is running. Shut off power to service, lubricate or remove mower blades, augers or PTO shafts.

Handle Chemical Products Safely

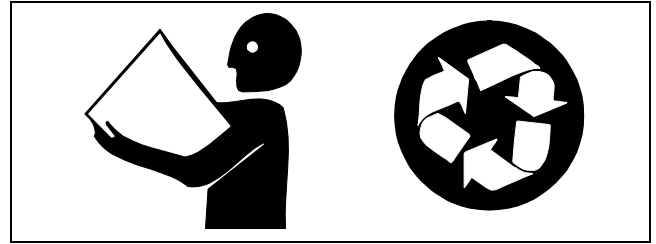

Direct exposure to hazardous chemicals can cause serious injury. Potentially hazardous chemicals used with John Deere equipment include such items as lubricants, coolants, paints, and adhesives.

A Material Safety Data Sheet (MSDS) provides specific details on chemical products: physical and health hazards, safety procedures, and emergency response techniques. Check the MSDS before you start any job using a hazardous chemical. That way you will know exactly what the risks are and how to do the job safely. Then follow procedures and recommended equipment.

Dispose Of Waste Properly

Improperly disposing of waste can threaten the environment and ecology. Potentially harmful waste used with John Deere equipment include such items as oil, fuel, coolant, brake fluid, filters, and batteries. Use leakproof containers when draining fluids. Do not use food or beverage containers that may mislead someone into drinking from them. Do not pour waste onto the ground, down a drain, or into any water source. Inquire on the proper way to recycle or dispose of waste from your local environmental or recycling center, or from your John Deere dealer.

Live With Safety



Before returning machine to customer, make sure machine is functioning properly, especially the safety systems. Install all guards and shields.

SPECIFICATIONS & INFORMATION / TABLE OF CONTENTS

Table of Contents

Specifications	7
Engine	7
Fuel System	8
Electrical	8
Transaxle	9
PTO Drive	9
Steering	10
Implement Lift	10
Tires	10
Dimensions	10
Mower Decks	10
Recommended Lubricants	11
Fastener Torques	12
Metric Fastener Torque Values	12
Metric Fastener Torque Value—grade 7	13
Inch Fastener Torque Values	13
General Information	15
Gasoline	15
Gasoline Storage	15
Engine Oil	15
Engine Break-in Oil	16
Alternative Lubricants	16
Synthetic Lubricants	17
Lubricant Storage	17
Mixing Of Lubricants	17
Chassis Grease	17
Hydrostatic Transmission Oil	17
Serial Number Locations	18
Machine Product Identification Number	18
Engine Serial Number	18
Transaxle Serial Number	18

SPECIFICATIONS & INFORMATION / TABLE OF CONTENTS



SPECIFICATIONS & INFORMATION / SPECIFICATIONS

Specifications

Engine

L1742

Make.....	Briggs & Stratton
Model.....	Intek / 31E707
Horsepower.....	12.7 kW (17.0 hp)
Displacement.....	508 cm ³ (31 cu in.)
Cylinders.....	1
Stroke/Cycle.....	4
Valves.....	Overhead
Lubrication.....	Pressurized
Oil Filter.....	None
Crankcase Capacity (Without Filter).....	1.4 L (1.5 qt)
Cooling System.....	Air Cooled
Air Cleaner.....	Paper with outer foam element
Muffler.....	Horizontal discharge below frame
Spark Plug Gap.....	1 mm (0.040 in.)
Spark Plug Torque.....	26 N•m (240 lb-in.)

L17.542

Make.....	Kohler
Model.....	Command / CV490S
Horsepower.....	13.1 kW (17.5 hp)
Displacement.....	490 cm ³ (29.9 cu in.)
Cylinders.....	1
Stroke/Cycle.....	4
Valves.....	Overhead
Lubrication.....	Pressurized
Oil Filter.....	Single Element, Full Flow, Spin-On Filter
Crankcase Capacity (With Filter).....	1.9 L (2.0 qt)
Crankcase Capacity (Without Filter).....	1.8 L (1.75 qt)
Cooling System.....	Air Cooled
Air Cleaner.....	Paper with outer foam element
Muffler.....	Horizontal discharge below frame
Spark Plug Gap.....	1 mm (0.040 in.)
Spark Plug Torque.....	26 N•m (240 lb-in.)

L2048

Make.....	Briggs & Stratton
Model.....	Intek V-Twin / 406777
Horsepower.....	14.9 kW (20 HP)
Displacement.....	656 cm ³ (40.0 cu in.)

SPECIFICATIONS & INFORMATION / SPECIFICATIONS

Cylinders	2
Stoke/Cycle	4
Valves	Overhead
Lubrication	Pressurized
Oil Filter	Single Element, Full Flow, Spin-On Filter
Crankcase Capacity (With Filter)	1.9 L (2.0 qt)
Crankcase Capacity (Without Filter)	1.7 L (1.9 qt)
Cooling System	Air Cooled
Air Cleaner	Dry, Replaceable Foam
Muffler	Horizontal Discharge Below Frame
Spark Plug Gap	0.76 mm (0.030 in.)
Spark Plug Torque	26 N•m (240 lb-in.)

L2548

Make	Briggs & Stratton
Model	Intek V-Twin / 445777
Horsepower	18.64 kW (25 HP)
Displacement	724 cm ³ (44.2 cu in.)
Cylinders	2
Stoke/Cycle	4
Valves	Overhead
Lubrication	Pressurized
Oil Filter	Single Element, Full Flow, Spin-On Filter
Crankcase Capacity (With Filter)	1.9 L (2.0 qt)
Crankcase Capacity (Without Filter)	1.8 L (1.75 qt)
Cooling System	Air Cooled
Air Cleaner	Dry, Replaceable Foam
Muffler	Horizontal discharge below frame
Spark Plug Gap	0.76 mm (0.030 in.)
Spark Plug Torque	26 N•m (240 lb-in.)

Fuel System

Fuel Tank Location	Rear
Fuel Tank Capacity	7.9 L (2.1 gal)
Fuel Type (minimum octane)	Unleaded, 87 Octane
Fuel Delivery	Float-Type Side Draft Carburetor
Fuel Pump	Vacuum Operated
Fuel Filter	Replaceable In-Line
Fuel Filter Opening/Location	7.6 cm (3 in.) Diameter/Left Rear Fender

Electrical

Ignition	Electronic Capacitor Discharge Ignition (CDI)
Type of Starter	Bendix

SPECIFICATIONS & INFORMATION / SPECIFICATIONS

Charging System Flywheel Alternator

Battery

Voltage 12

BCI group U-1

CCA rating (Amps At -18°C (0°F)) 160

Reserve capacity (Minutes At 25 Amps) 20

Specific gravity (Minimum) 1.225 points

Electrolyte required fill (Approximate) 1.9 L (2.0 qt)

Load test (Minimum) 255 amp for 15 seconds

Transaxle

Gear Transaxle

Make Dana

Model (L1742) Spicer Heavy-Duty 4360 Transaxle

Type Five-Speed/Linear Shift

Ground Speeds (At Fast Idle—3350 rpm) and Gear Ratios:

1st Gear 2.4 km/hr (1.5 mph)—61.67:1

2nd Gear 3.2 km/hr (2.0 mph)—46.67:1

3rd Gear 5.0 km/hr (3.1 mph)—30.00:1

4th Gear 6.4 km/hr (4.0 mph)—23.48:1

5th Gear 8.0 km/hr (5.0 mph)—18.46:1

Reverse 3.7 km/hr (2.3 mph)—40.00:1

Brake Type Single, External Brake Disc With Dual Friction Pucks

Lubrication—Input Shaft Needle Bearings Unirex® N3 Grease Only (M120263)

Lubrication—Transaxle Shell Darina® D Grease Only (AM119608)

Capacity—Transaxle 0.64 kg (1.406 lbs)

Hydrostatic Transaxle:

Make Tuff Torq®

Model (L17.542) K46V (7A6460)

Model (L2048 and L2548) K46AC (7A6460) (Heavy-Duty)

Drive Train Belt Drive Transaxle with foot-controlled variable speed drive

Travel Speed-Forward (L17.542) 0 – 9.2 km/h (0 – 5.7 mph)

Travel Speed-Forward (L2048 and L2548) 0 – 8.4 km/h (0 – 5.2 mph)

Travel Speed-Reverse (L17.542) 0 – 5.5 km/h (0 – 3.4 mph)

Travel Speed-Reverse (L2048 and L2548) 0 – 4.7 km/h (0 – 2.9 mph)

Brake type Single, Internal Wet Disc Brake

PTO Drive

Type V-Belt

Clutch Type (L1742 and L17.542) Mechanical

Clutch Type (L2048 and L2548) Electric

SPECIFICATIONS & INFORMATION / SPECIFICATIONS

Control..... Lever or knob on Dash

Steering

Type..... Sector and Pinion
Turning Radius..... 46 cm (18 in.)

Implement Lift

Lift System..... Manual
Lift Arm Location..... Left-hand side

Tires

L1742 and L17.542

Front Tire Size..... 15 x 6.00 x 6
Front Tire Pressure..... 97 kPa (14 psi)
Rear Tire Size..... 20 x 8.00 x 8
Rear Tire Pressure..... 69 kPa (10 psi)

L2048 and L2548

Front Tire Size..... 16 x 6.50 x 8
Front Tire Pressure..... 97 kPa (14 psi)
Rear Tire Size..... 22 x 9.50 x 12
Rear Tire Pressure..... 69 kPa (10 psi)

Dimensions

Overall Length..... 152.4 cm (60.0 in.)
Overall Width (without mower)..... 91.0 cm (36.0 in.)
Overall Height..... 98.0 cm (38.6 in.)

Net Weight (No Fuel)

L1742 and L17.542..... 210 kg (462 lbs)
L2048 and L2548..... 241 kg (532 lbs)

Mower Decks

42-Inch Mower Deck:

Type..... Rotary - Mulch, Bag or Side Discharge
Cutting Blade..... Two—63.5 x 4 x 545 mm (2.5 x 0.16 x 21.5 in.)
Blade Cutting Edge..... 30 ± 5° Angle
Overall Cutting Width..... 106.7 cm (42 in.)
Cutting Height (approximate)..... 25 – 102 mm (1 – 4 in.)
Blade cap screw..... 62 N•m (46 lb-ft)
Gage wheels-to-deck..... 34 N•m (25 lb-ft)
Spindle mounting screws..... 27 N•m (20 lb-ft)
Spindle Lubrication..... Do not grease

SPECIFICATIONS & INFORMATION / SPECIFICATIONS

48-Inch Mower Deck:

Type	Rotary - Mulch, Bag or Side Discharge
Cutting Blade	Three—63.5 x 4 x 433 mm (2.5 x 0.16 x 17 in.)
Blade Cutting Edge	30 ± 5° Angle
Overall Cutting Width	121.9 cm (48 in.)
Cutting Height (approximate)	25 – 102 mm (1 – 4 in.)
Blade cap screw	62 N•m (46 lb-ft)
Gage wheels to deck	30 N•m (22 lb-ft)
Spindle mounting screws	27 N•m (20 lb-ft)
Spindle lubrication	Do not grease

Recommended Lubricants

Engine Oil	TURF-GARD® OR PLUS-4®
Transmission Oil	John Deere Low Viscosity HY-GARD® (J20D)

Grease:

- John Deere MOLY HIGH TEMPERATURE EP GREASE
- John Deere Multi-Purpose SD Polyurea Grease
- John Deere Multi-Purpose HD Lithium Complex Grease

(Specifications and design subject to change without notice.)

SPECIFICATIONS & INFORMATION / FASTENER TORQUES

Fastener Torques

Metric Fastener Torque Values

Property Class and Head Markings	<p>4.8</p>	<p>8.8 9.8</p>	<p>10.9</p>	<p>12.9</p>
Property Class and Nut Markings	<p>5</p>	<p>10</p>	<p>10</p>	<p>12</p>

TS1163

SIZE	Class 4.8				Class 8.8 or 9.8				Class 10.9				Class 12.9			
	Lubricated a		Dry a		Lubricated a		Dry a		Lubricated a		Dry a		Lubricated a		Dry a	
	N•m	lb-ft	N•m	lb-ft	N•m	lb-ft	N•m	lb-ft	N•m	lb-ft	N•m	lb-ft	N•m	lb-ft	N•m	lb-ft
M6	4.8	3.5	6	4.5	9	6.5	11	8.5	13	9.5	17	12	15	11.5	19	14.5
M8	12	8.5	15	11	22	16	28	20	32	24	40	30	37	28	47	35
M10	23	17	29	21	43	32	55	40	63	47	80	60	75	55	95	70
M12	40	29	50	37	75	55	95	70	110	80	140	105	130	95	165	120
M14	63	47	80	60	120	88	150	110	175	130	225	165	205	150	260	109
M16	100	73	125	92	190	140	240	175	275	200	350	225	320	240	400	300
M18	135	100	175	125	260	195	330	250	375	275	475	350	440	325	560	410
M20	190	140	240	180	375	275	475	350	530	400	675	500	625	460	800	580
M22	260	190	330	250	510	375	650	475	725	540	925	675	850	625	1075	800
M24	330	250	425	310	650	475	825	600	925	675	1150	850	1075	800	1350	1000
M27	490	360	625	450	950	700	1200	875	1350	1000	1700	1250	1600	1150	2000	1500
M30	675	490	850	625	1300	950	1650	1200	1850	1350	2300	1700	2150	1600	2700	2000
M33	900	675	1150	850	1750	1300	2200	1650	2500	1850	3150	2350	2900	2150	3700	2750
M36	1150	850	1450	1075	2250	1650	2850	2100	3200	2350	4050	3000	3750	2750	4750	3500

DO NOT use these hand torque values if a different torque value or tightening procedure is given for a specific application. Torque values listed are for general use only and include a $\pm 10\%$ variance factor. Check tightness of fasteners periodically. DO NOT use air powered wrenches.

Shear bolts are designed to fail under predetermined loads. Always replace shear bolts with identical grade.

Fasteners should be replaced with the same class. Make sure fastener threads are clean and that you properly start thread engagement. This will prevent them from failing when tightening.

When bolt and nut combination fasteners are used, torque values should be applied to the NUT instead of the bolt head.

Tighten toothed or serrated-type lock nuts to the full torque value.

a "Lubricated" means coated with a lubricant such as engine oil, or fasteners with phosphate and oil coatings. "Dry" means plain or zinc plated (Yellow Dichromate - Specification JDS117) without any lubrication.

Reference: JDS—G200











SPECIFICATIONS & INFORMATION / FASTENER TORQUES

Metric Fastener Torque Value—grade 7

Size	Steel or Gray Iron Torque		Aluminum Torque	
	N•m	lb-ft	N•m	lb-ft
M6	11	8	8	6
M8	24	18	19	14
M10	52	38	41	30

Size	Steel or Gray Iron Torque		Aluminum Torque	
	N•m	lb-ft	N•m	lb-ft
M12	88	65	70	52
M14	138	102	111	82
M16	224	165	179	132

Inch Fastener Torque Values

SAE Grade and Head Markings	1 or 2 ^b		5 5.1 5.2			8 8.2	
	No Marks						
SAE Grade and Nut Markings	2		5			8	
No Marks							

TS1162

TS1162

SIZE	Grade 1				Grade 2b				Grade 5, 5.1 or 5.2				Grade 8 or 8.2			
	Lubricated a		Dry a		Lubricated a		Dry a		Lubricated a		Dry a		Lubricated a		Dry a	
	N•m	lb-ft	N•m	lb-ft	N•m	lb-ft	N•m	lb-ft	N•m	lb-ft	N•m	lb-ft	N•m	lb-ft	N•m	lb-ft
1/4	3.7	2.8	4.7	3.5	6	4.5	7.5	5.5	9.5	7	12	9	13.5	10	17	12.5
5/16	7.7	5.5	10	7	12	9	15	11	20	15	25	18	28	21	35	26
3/8	14	10	17	13	22	16	27	20	35	26	44	33	50	36	63	46
7/16	22	16	28	20	35	26	44	32	55	41	70	52	80	58	100	75
1/2	33	25	42	31	53	39	67	50	85	63	110	80	120	90	150	115
9/16	48	36	60	45	75	56	95	70	125	90	155	115	175	130	225	160
5/8	67	50	85	62	105	78	135	100	170	125	215	160	215	160	300	225
3/4	120	87	150	110	190	140	240	175	300	225	375	280	425	310	550	400
7/8	190	140	240	175	190	140	240	175	490	360	625	450	700	500	875	650
1	290	210	360	270	290	210	360	270	725	540	925	675	1050	750	1300	975
1-1/8	470	300	510	375	470	300	510	375	900	675	1150	850	1450	1075	1850	1350
1-1/4	570	425	725	530	570	425	725	530	1300	950	1650	1200	2050	1500	2600	1950
1-3/8	750	550	950	700	750	550	950	700	1700	1250	2150	1550	2700	2000	3400	2550
1-1/2	1000	725	1250	925	990	725	1250	930	2250	1650	2850	2100	3600	2650	4550	3350

SPECIFICATIONS & INFORMATION / FASTENER TORQUES

DO NOT use these hand torque values if a different torque value or tightening procedure is given for a specific application. Torque values listed are for general use only and include a $\pm 10\%$ variance factor. Check tightness of fasteners periodically. DO NOT use air powered wrenches.

Shear bolts are designed to fail under predetermined loads. Always replace shear bolts with identical grade.

Fasteners should be replaced with the same grade. Make sure fastener threads are clean and that you properly start thread engagement. This will prevent them from failing when tightening.

When bolt and nut combination fasteners are used, torque values should be applied to the NUT instead of the bolt head.

Tighten toothed or serrated-type lock nuts to the full torque value.

a *“Lubricated” means coated with a lubricant such as engine oil, or fasteners with phosphate and oil coatings.*

“Dry” means plain or zinc plated (yellow dichromate - Specification JDS117) without any lubrication.

b *“Grade 2” applies for hex cap screws (Not Hex Bolts) up to 152 mm (6—in.) long. “Grade 1” applies for hex cap screws over 152 mm (6—in.) long, and for all other types of bolts and screws of any length.*

Reference: JDS—G200

SPECIFICATIONS & INFORMATION / GENERAL INFORMATION

General Information

Gasoline



CAUTION: Avoid injury! Gasoline is HIGHLY FLAMMABLE, handle it with care. DO NOT refuel machine while:

- indoors, always fill gas tank outdoors
- machine is near an open flame or sparks
- engine is running, STOP engine
- engine is hot, allow it to cool sufficiently first
- smoking

Help prevent fires:

- fill gas tank to bottom of filler neck only
- be sure fill cap is tight after fueling
- clean up any gas spills IMMEDIATELY
- keep machine clean and in good repair—free of excess grease, oil, debris, and faulty or damaged parts
- any storage of machines with gas left in tank should be in an area that is well ventilated to prevent possible igniting of fumes by an open flame or spark, this includes any appliance with a pilot light

To prevent fire or explosion caused by STATIC ELECTRIC DISCHARGE during fueling:

ONLY use a clean, approved POLYETHYLENE PLASTIC fuel container and funnel WITHOUT any metal screen or filter

To avoid engine damage:

- DO NOT mix oil with gasoline
- ONLY use clean, fresh unleaded gasoline with an octane rating (anti-knock index) of 87 or higher**
- fill gas tank at the end of each day's operation to help prevent condensation from forming inside a partially filled tank
- keep up with specified service intervals

Use of alternative oxygenated, gasohol blended, unleaded gasoline is acceptable as long as:

- the ethyl or grain alcohol blends DO NOT exceed 10% by volume or

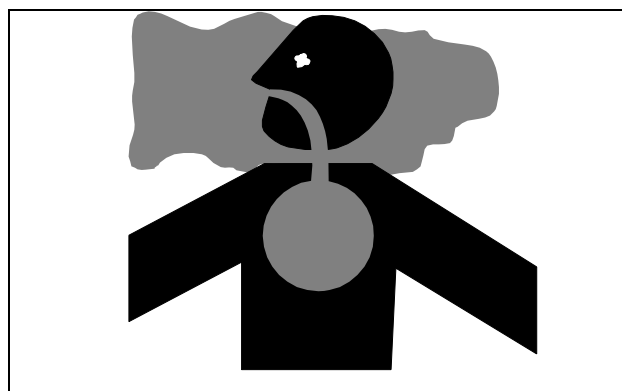

mif

- methyl tertiary butyl ether (MTBE) blends DO NOT exceed 15% by volume

IMPORTANT: Avoid damage! DO NOT use METHANOL gasolines because METHANOL is harmful to the environment and to your health.



CAUTION: Avoid injury! California Proposition 65 Warning: Gasoline engine exhaust from this product contains chemicals known to the State of California to cause cancer, birth defects, or other reproductive harm.

Gasoline Storage

IMPORTANT: Avoid damage! Keep all dirt, scale, water or other foreign material out of gasoline.

Keep gasoline stored in a safe, protected area. Storage of gasoline in a clean, properly marked ("UNLEADED GASOLINE") POLYETHYLENE PLASTIC container WITHOUT any metal screen or filter is recommended. DO NOT use de-icers to attempt to remove water from gasoline or depend on fuel filters to remove water from gasoline. Use a water separator installed in the storage tank outlet. BE SURE to properly discard unstable or contaminated gasoline. When storing unit or gasoline, it is recommended that you add **John Deere Gasoline Conditioner and Stabilizer (TY15977)** or an equivalent to the gasoline. BE SURE to follow directions on container and to properly discard empty container.

Engine Oil

Use the appropriate oil viscosity based on the expected air temperature range during the period between recommended oil changes. Operating outside of these recommended oil air temperature ranges may cause premature engine failure.

The following John Deere oil is PREFERRED:

SPECIFICATIONS & INFORMATION / GENERAL INFORMATION

- **TURF-GARD®—SAE 10W-30;**
- **PLUS-4®—SAE 10W-30;**

Other oils may be used if above John Deere oils are not available, provided they meet one of the following specifications:

- SAE 5W-30—API Service Classification SG or higher;
- SAE 10W-30—API Service Classification SG or higher;
- SAE 30—API Service Classification SC or higher.

John Deere Dealers: You may want to cross-reference the following publications to recommend the proper oil for your customers:

- Module DX, ENOIL2 in JDS-G135;
- Section 530, Lubricants & Hydraulics, of the John Deere Merchandise Sales Guide;
- Lubrication Sales Manual PI7032.

Engine Break-in Oil

IMPORTANT: Avoid damage! ONLY use a quality break-in oil in rebuilt or remanufactured engines for the first 5 hours (maximum) of operation. DO NOT use oils with heavier viscosity weights than SAE 5W-30 or oils meeting specifications API SG or SH, these oils will not allow rebuilt or remanufactured engines to break-in properly.

The following John Deere oil is **PREFERRED**:

- **BREAK-IN ENGINE OIL.**

John Deere **BREAK-IN ENGINE OIL** is formulated with special additives for aluminum and cast iron type engines to allow the power cylinder components (pistons, rings, and liners as well) to “wear-in” while protecting other engine components, valve train and gears, from abnormal wear. Engine rebuild instructions should be followed closely to determine if special requirements are necessary.

John Deere **BREAK-IN ENGINE OIL** is also recommended for non-John Deere engines, both aluminum and cast iron types.

The following John Deere oil is **also recommended as a break-in engine oil**:

- **TORQ-GARD SUPREME®—SAE 5W-30.**

If the above recommended John Deere oils are not available, use a break-in engine oil meeting the following specification during the first 5 hours (maximum) of operation:

- SAE 5W-30—API Service Classification SE or higher.

IMPORTANT: Avoid damage! After the break-in period, use the John Deere oil that is recommended for this engine.

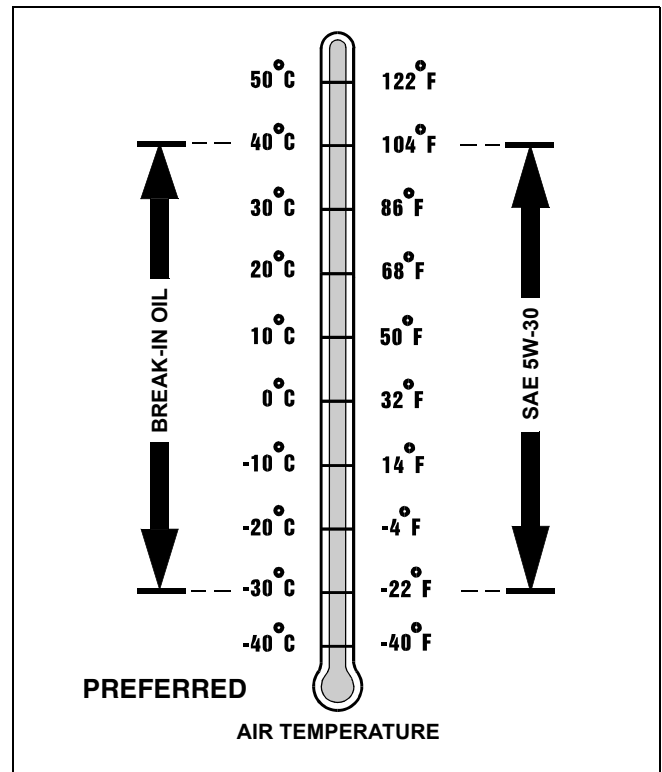

M58275

John Deere Dealers: You may want to cross-reference the following publications to recommend the proper oil for your customers:

- Module DX, ENOIL4 in JDS-G135;
- Section 530, Lubricants & Hydraulics, of the John Deere Merchandise Sales Guide;
- Lubrication Sales Manual PI7032.

Alternative Lubricants

Conditions in certain geographical areas outside the United States and Canada may require different lubricant recommendations than the ones printed in this technical manual or the operator's manual. Consult with your John Deere Dealer, or Sales Branch, to obtain the alternative lubricant recommendations.

IMPORTANT: Avoid damage! Use of alternative lubricants could cause reduced life of the component.

If alternative lubricants are to be used, it is recommended that the factory fill be thoroughly removed before switching to any alternative lubricant.

SPECIFICATIONS & INFORMATION / GENERAL INFORMATION

Synthetic Lubricants

Synthetic lubricants may be used in John Deere equipment if they meet the applicable performance requirements (industry classification and/or military specification) as shown in this manual.

The recommended air temperature limits and service or lubricant change intervals should be maintained as shown in the operator's manual.

Avoid mixing different brands, grades, or types of oil. Oil manufacturers blend additives in their oils to meet certain specifications and performance requirements. Mixing different oils can interfere with the proper functioning of these additives and degrade lubricant performance.

Lubricant Storage

All machines operate at top efficiency only when clean lubricants are used. Use clean storage containers to handle all lubricants. Store them in an area protected from dust, moisture, and other contamination. Store drums on their sides. Make sure all containers are properly marked as to their contents. Dispose of all old, used containers and their contents properly.

Mixing Of Lubricants

In general, avoid mixing different brands or types of lubricants. Manufacturers blend additives in their lubricants to meet certain specifications and performance requirements. Mixing different lubricants can interfere with the proper functioning of these additives and lubricant properties which will downgrade their intended specified performance.

Chassis Grease

Use the following grease based on the air temperature range. Operating outside of the recommended grease air temperature range may cause premature failures.

The following John Deere grease is PREFERRED:

- **NON-CLAY HIGH-TEMPERATURE EP GREASE®—JDM J13E4, NLGI Grade 2.**

- Multi-Purpose SD Polyurea Grease
- Multi-Purpose HD Lithium Complex Grease

Other greases may be used if above preferred John Deere grease is not available, provided they meet the following specification:

- John Deere Standard JDM J13E4, NLGI Grade 2.

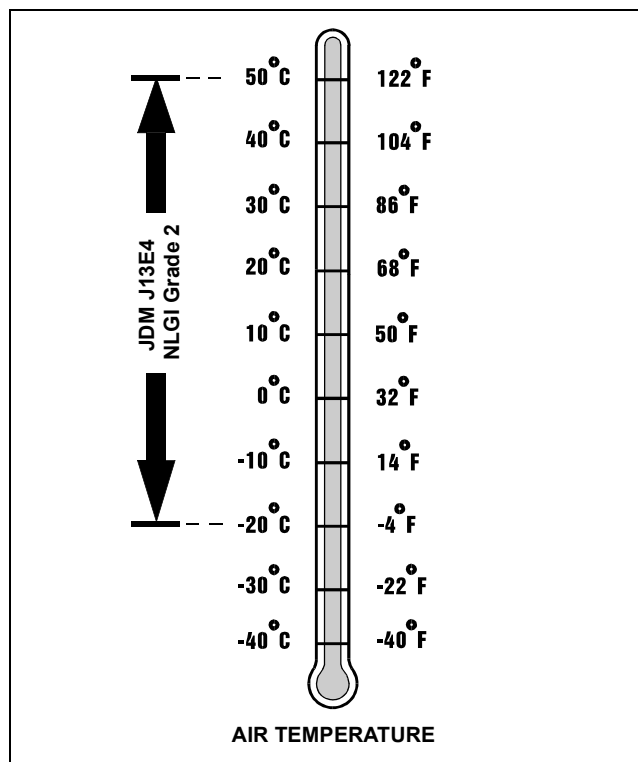

M58275

John Deere Dealers: You may want to cross-reference the following publications to recommend the proper grease for your customers:

- Module DX,GREA1 in JDS–G135;
- Section 530, Lubricants & Hydraulics, of the John Deere Merchandise Sales Guide;
- Lubrication Sales Manual P17032.

Hydrostatic Transmission Oil

These tractors are equipped with a internal wet disc brake transmission.

IMPORTANT: Avoid damage! ONLY use HY-GARD® J20D oil in this transmission. Mixing of two viscosity grade oils is NOT RECOMMENDED. DO NOT use type “F” automatic transmission fluid.

The following oil is RECOMMENDED:

- **HY-GARD J20D OIL**

John Deere Dealers: You may want to cross-reference the following publications to recommend the proper oil for your customers:

- Module DX,ENOIL2 in JDS–G135;
- Section 530, Lubricants & Hydraulics, of the John Deere Merchandise Sales Guide;
- Lubrication Sales Manual PI7032.

SPECIFICATIONS & INFORMATION / SERIAL NUMBER LOCATIONS

Serial Number Locations

Machine Product Identification Number

When ordering parts or submitting a warranty claim, it is **IMPORTANT** that the machine product identification number (PIN) and component serial numbers are included. The location of the PIN and component serial numbers are shown.

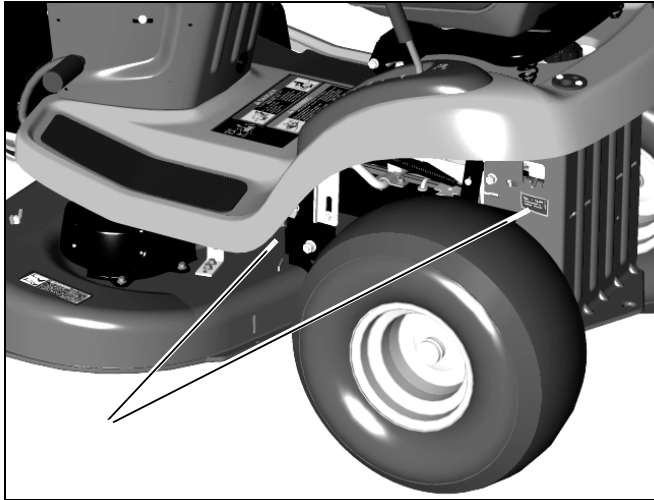

MX7694

Machine: Located on LH side of frame.

Mower Deck: Located on rear left side of deck.

Engine Serial Number



MX9662

Located on RH side of engine.

Transaxle Serial Number

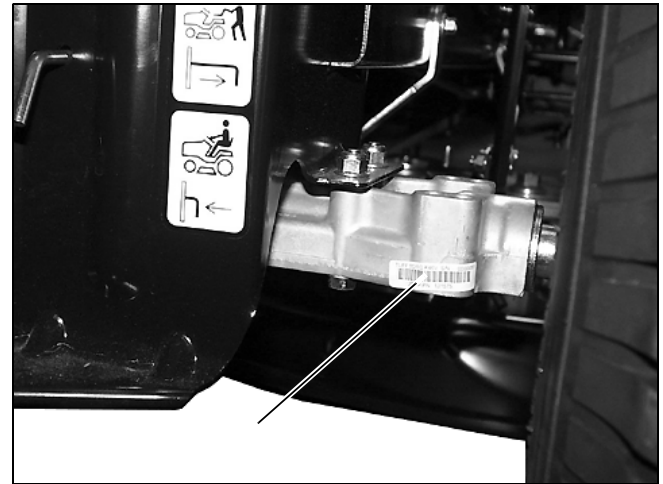

MX9663

Located on back-right side of transaxle.

ENGINE - 17 HP BRIGGS & STRATTON / TABLE OF CONTENTS

Table of Contents

Specifications21

General Specifications21

Tests and Adjustments Specifications21

Repair Specifications21

Torque Specifications (Alphabetical)22

Tests and Adjustments24

Throttle Cable Adjustment24

Throttle Cable Adjustment24

Fuel Shutoff Solenoid Test24

Governor Adjustment - Static25

Governor Adjustment - Dynamic25

Governor Idle Adjustment26

Slow Idle Carburetor Adjustment26

Valve Clearance Adjustment27

Armature Air Gap Adjustment28

Cylinder Leakdown Test28

Fuel and Air Repair30

Upper Blower Housing Removal and
Installation30

Air Cleaner Service30

Carburetor Removal and Installation31

Carburetor Disassembly32

Carburetor Inspection33

Carburetor Assembly33

Breather Valve Service34

Engine Repair34

Engine Removal34

Engine Installation35

Cylinder Head Removal and
Installation36

Cylinder Head Inspection and Repair39

Valve Removal39

Valves Reface39

Valves Installation40

Governor Removal and Installation41

Piston, Rings and Rod41

Piston Inspection43

Connecting Rod Inspection43

Cylinder Bore Inspection45

Cylinder Bore Honing45

Cylinder Bore Cleaning46

Resizing Cylinder Bore46

Flywheel Removal and Installation47

Crankshaft and Cam Gear Removal48

Balance System Removal and Installation	49
Crankshaft/Cam Gear Installation	50
Magneto Bearing Inspection	51
Cam Gear Bearing Inspection	52
PTO Journal Inspection and Seal Replacement	52
Starting Motor Removal and Installation	52
Starting Motor Disassembly	53
Starting Motor Assembly	55
Starting Motor Pinion Gear Replacement	56

ENGINE - 17 HP BRIGGS & STRATTON / TABLE OF CONTENTS



ENGINE - 17 HP BRIGGS & STRATTON / SPECIFICATIONS

Specifications

General Specifications

Make	Briggs & Stratton
Series	I/C® OHV Model 28
Model	314777
Horsepower	12.7 kW (17 hp)
Cylinders	1
Displacement	500 cm ³ (30.52 cu in.)
Stroke/Cycle	4
Valves	Overhead Valves
Bore	90.47 mm (3.562 in.)
Stroke	77.8 mm (3.06 in.)
Crankcase Oil Capacity	1.42 L (1.5 qt)
Cooling System	Air Cooled
Air Cleaner	Paper with outer foam element
Muffler	Horizontal discharge below frame
Aspiration	Normal
Fuel Filter	Replaceable (In-Line Type)

Tests and Adjustments Specifications

Valve Clearance	
Intake	0.08 – 0.13 mm (0.003 – 0.005 in.)
Exhaust	0.13 – 0.18 mm (0.005 – 0.007 in.)
Valve Guide Depth	0.12 – 0.15 mm (0.005 – 0.006 in.)
Slow Idle	1700 ± 50 rpm
Fast Idle	3350 ± 50 rpm
Magneto Air Gap	0.20 – 0.35 mm (0.008 – 0.014 in.)
Spark Plug Gap	0.76 mm (0.030 in.)

Repair Specifications

Cylinder Bore, Pistons and Rings:

Cylinder Bore Standard	
Maximum Dimension	90.50 mm (3.563 in.)
Minimum Dimension	90.47 mm (3.562 in.)
Cylinder Bore Out of Round (max)	0.04 mm (0.0015 in.)
Piston Pin (Wear Limit)	20.29 mm (0.799 in.)
Piston Pin Bore (Wear Limit)	20.35 mm (0.801 in.)

Ring End Gap (Wear Limit) Case Iron Bore:

Compression Ring (Top)	0.64 mm (0.025 in.)
Compression Ring (Center)	0.76 mm (0.030 in.)
Oil Ring	0.76 mm (0.030 in.)

ENGINE - 17 HP BRIGGS & STRATTON / SPECIFICATIONS

Compression and Oil Ring Groove Wear Limit (New Ring Installed) 0.15 mm (0.006 in.)

Valves:

Valve Guide (Wear Limit) 6.09 mm (0.240 in.)

Valve Seat Width 0.79 – 1.98 mm (0.031 – 0.078 in.)

Valve Margin (Minimum). 0.40 mm (0.016 in.)

Valve Face Angle 45°

Valve Seat Narrowing Angle 30°

Connecting Rod and Crankshaft:

Connecting Rod Crankpin (Wear Limit) 38.32 mm (1.509 in.)

Connecting Rod Piston Pin Bearing (Wear Limit) 20.37 mm (0.802 in.)

Crankshaft PTO Journal (Wear Limit). 34.95 mm (1.376 in.)

Crankshaft Magneto Journal (Wear Limit) 34.95 mm (1.376 in.)

Crankshaft Crankpin Journal (Wear Limit). 38.02 mm (1.497 in.)

Crankshaft Eccentric Journal (Wear Limit) 55.93 mm (2.202 in.)

PTO Bearing (Wear Limit) 35.13 mm (1.383 in.)

Magneto Bearing (Wear Limit). 35.13 mm (1.383 in.)

Crankshaft End Play. 0.05 – 0.58 mm (0.002 – 0.023 in.)

Cam Gear PTO Journal (Wear Limit). 12.65 mm (0.498 in.)

Cam Gear Magneto Journal (Wear Limit). 12.65 mm (0.498 in.)

Cam Lobe (Wear Limit) 30.07 mm (1.184 in.)

Cam Gear Bearing (Wear Limit). 12.8 mm (0.504 in.)

Counterweight:

Crankshaft Eccentric Journal (Wear Limit) 55.93 mm (2.202 in.)

Counterweight Link Bearing (Wear Limit) 56.13 mm (2.210 in.)

Torque Specifications (Alphabetical)

Blower Housing Screws. 9.6 N•m (85 lb-in.)

Breather Mounting Bolt 6.2 N•m (55 lb-in.)

Breather Reed Screw 3.4 N•m (30 lb-in.)

Carburetor to Intake Manifold 8 N•m (70 lb-in.)

Carburetor Bowl Screw 4.5 N•m (40 lb-in.)

Connecting Rod Cap Screws 21 N•m (186 lb-in.)

Control Bracket Screws 3.4 N•m (30 lb-in.)

Cylinder Head Cap Screws 25 N•m (220 lb-in.)

Dip Stick Tube Mounting Screw 2.8 N•m (25 lb-in.)

Drive Belt Idler Pulley. 9.6 N•m (85 lb-in.)

Engine Mounting Bolts 32 N•m (24 lb-ft)

Engine Output Pulley Assembly 75 N•m (55 lb-ft)

Exhaust Manifold 18.5 N•m (165 lb-in.)

Flywheel Fan Screws 16 N•m (140 lb-in.)

Flywheel Nut 136 N•m (100 lb-ft)

ENGINE - 17 HP BRIGGS & STRATTON / SPECIFICATIONS

Flywheel Screen Screws	4.5 N•m (40 lb-in.)
Fuel Pump Bracket	7.3 N•m (65 lb-in.)
Fuel Pump to Bracket	4.0 N•m (35 lb-in.)
Fuel Shutoff Solenoid	4.5 N•m (40 lb-in.)
Governor Arm Lock Nut	4.5 N•m (40 lb-in.)
Heat Shield Screws	4.5 N•m (40 lb-in.)
Ignition Armature	2.8 N•m (25 lb-in.)
Intake Manifold Elbow	11.3 N•m (100 lb-in.)
Rocker Arm Adjustment Lock Nut	6.8 N•m (60 lb-in.)
Rocker Arm Mounting	11.3 N•m (100 lb-in.)
Starting Motor Mounting Bolts	16 N•m (140 lb-in.)
Starting Motor Through Bolts	5.7 N•m (50 lb-in.)
Stator to Cylinder Block	2.3 N•m (21 lb-in.)
Spark Plug	20 N•m (180 lb-in.)
Sump Cover	20 N•m (180 lb-in.)
Throttle Valve Plate	4.5 N•m (40 lb-in.)
Valve Cover Nuts	6.2 N•m (55 lb-in.)
Voltage Regulator/Rectifier	7.3 N•m (65 lb-in.)

ENGINE - 17 HP BRIGGS & STRATTON / TESTS AND ADJUSTMENTS

Tests and Adjustments

Throttle Cable Adjustment

Reason:

To make sure the throttle cable moves the throttle through its full range of movement.

Procedure:

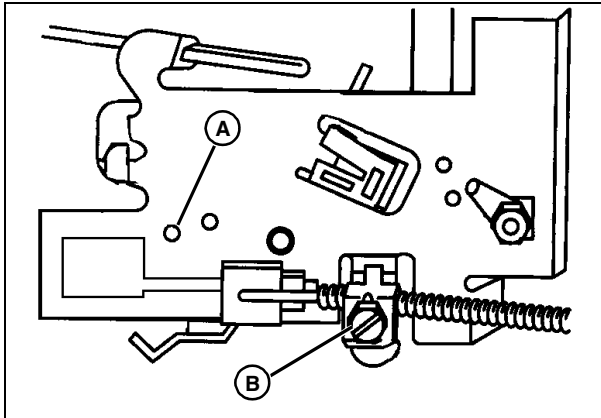

M95232

1. Move throttle lever to FAST idle position (detent).
2. Hole in governor control lever must align with hole (A) in governor control plate.
3. Loosen throttle cable clamp (B).
4. Slide the throttle cable left or right to align holes.
5. Tighten throttle cable clamp (B).

Throttle Cable Adjustment

Reason:

To make sure the throttle cable moves the throttle through its full range of movement.

Procedure:

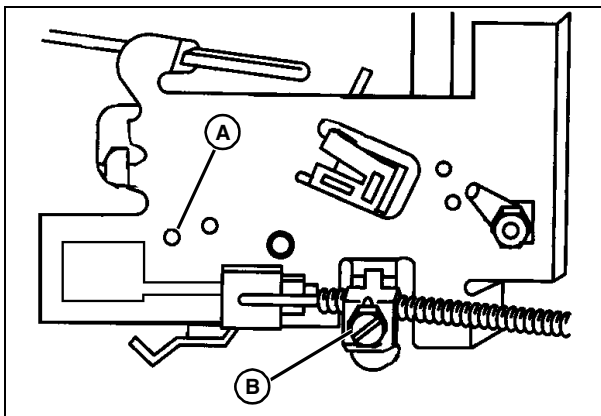

M95232

1. Move throttle lever to FAST idle position (detent).
2. Hole in governor control lever must align with hole (A) in governor control plate.
3. Loosen throttle cable clamp (B).
4. Slide the throttle cable left or right to align holes.
5. Tighten throttle cable clamp (B).

Fuel Shutoff Solenoid Test

Reason:

To test proper operation of fuel shutoff solenoid.

Required Tools:

- Jumper wire

Procedure:

1. Listen for an audible click when ignition switch is turned from OFF to ON.
2. If solenoid does not click, problem could be in equipment wiring.

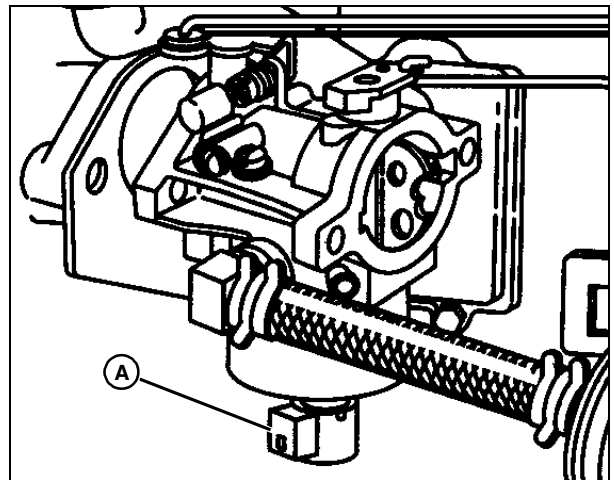

M95224

3. Disconnect wire from solenoid (A).
4. Momentarily place a jumper wire from solenoid terminal to battery positive terminal.

NOTE: If battery voltage drops below 9 volts when cranking engine or while engine is running, the solenoid will not function.

5. If solenoid now clicks, the solenoid is working properly.

Results:

- Solenoid is operating properly if a click is heard when ignition switched from OFF to ON.

Governor Adjustment - Static

ENGINE - 17 HP BRIGGS & STRATTON / TESTS AND ADJUSTMENTS

(Engine OFF)



CAUTION: Avoid injury! Before starting or running engine, static adjustment of the governor must be made. Failure to make static adjustments first, could result in engine overspeeding, and may result in engine or equipment damage causing personal injury and/or property damage.

NOTE: All linkage must be installed to make adjustment.

Reason:

To set the initial engine speed limits.

Procedure:

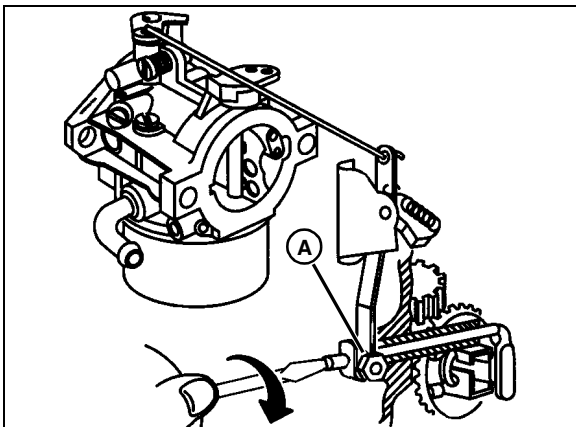

M95236

1. Loosen governor lever bolt and nut (A).
2. Move throttle lever to FAST idle position.

IMPORTANT: Avoid damage! Do not bend governor link or distort governor lever.

3. While holding throttle in fast position use a flat blade screwdriver to turn governor shaft clockwise until it stops.
4. Hold lever and shaft in position and tighten governor lever bolt and nut to specification.

Specification:

Lock nut. 4.5 N•m (40 lb-in.)

Governor Adjustment - Dynamic

(Full Throttle No Load)

Reason:

To verify the engine speed settings are within limits.

Equipment:

- JT07270 Pulse Tachometer



CAUTION: Avoid injury! Before starting or running engine, static adjustment of the governor must be made. Failure to make static adjustments first, could result in engine overspeeding, and may result in engine or equipment damage causing personal injury and/or property damage.

NOTE: All linkage must be installed to make adjustment.

Procedure:

IMPORTANT: Avoid damage! When servicing engine (when the engine is running), it is important to remove hood to avoid damage from muffler exhaust heat source.

1. Remove hood assembly. (See "Hood Removal and Installation" on page 313 in the Miscellaneous section.)
2. With engine running move throttle lever to FAST idle position.
3. Measure engine rpm.

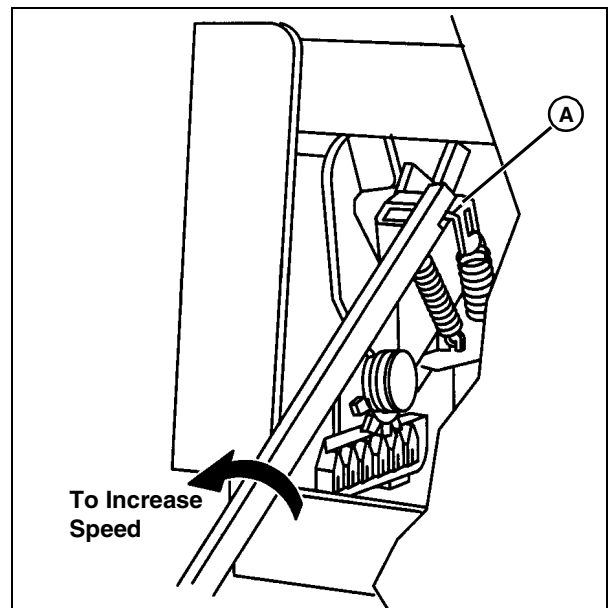

M95237

IMPORTANT: Avoid damage! Do not bend governor link or distort governor lever.

4. Bend the upper governor spring anchor (A) to adjust the top no load engine rpm to specification.
5. Bend the anchor up to lengthen the spring to increase the rpm, or down to shorten the spring to reduce the engine

ENGINE - 17 HP BRIGGS & STRATTON / TESTS AND ADJUSTMENTS

Product: John Deere L1642, L17542, L2048 and L2548 Scotts Lawn Tractor Service Repair Technical Manual

Full Download: <https://www.bobmanualstore.com/downloads/john-deere-l1642-l17542-l2048-and-l2548-scotts-lawn-tractor-service-repair-technical-manual/>

rpm
7-542-l2048-and-l2548-scotts-lawn-tractor-service-repair-technical-manual/

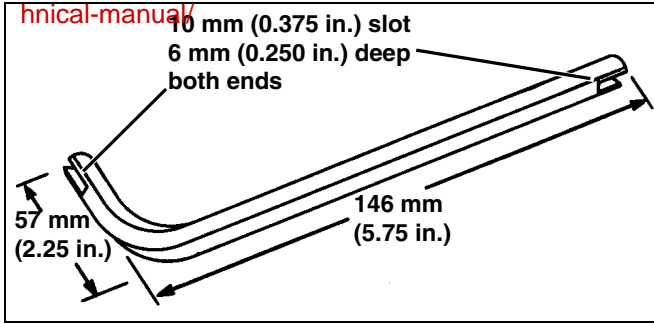

M95238

Specification:

Top No Load rpm 3350 ± 50 rpm

Governor Idle Adjustment

Reason:

To set the governed idle speed.

Equipment:

- JT07270 Pulse Tachometer

Procedure:

IMPORTANT: Avoid damage! When servicing engine (when the engine is running), it is important to remove hood to avoid damage from muffler exhaust heat source.

1. Remove hood assembly. (See “Hood Removal and Installation” on page 313 in the Miscellaneous section.)
2. Start engine and run at 1/2 throttle for 5 minutes to bring engine to operating temperature.
3. Move throttle to idle position.

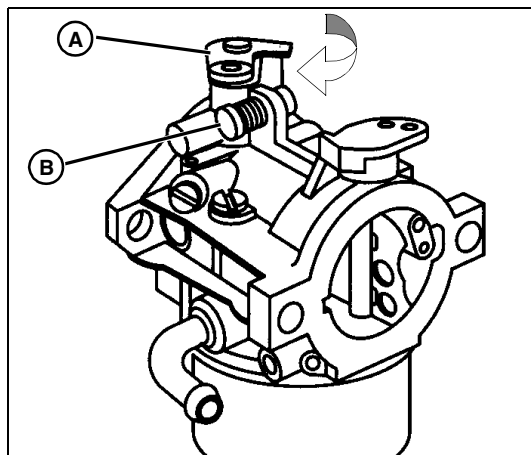

M95222

4. Hold throttle shaft (A) in closed position with finger, adjust idle speed screw (B) to 1200 rpm.

Sample manual. Download All 334 pages at:

<https://www.bobmanualstore.com/downloads/john-deere-l1642-l17542-l2048-and-l2548-scotts-lawn-tractor-service-repair-technical-manual/>

5. Release throttle.

6. Set throttle to 1700 ± 50 rpm.

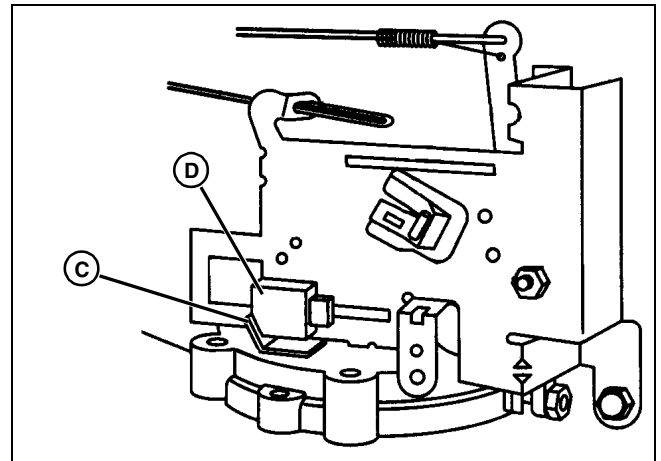

M95239

7. Bend tang (C) until it contacts remote control slide (D).

Specification:

Governor Idle rpm 1700 ± 50 rpm

Slow Idle Carburetor Adjustment

Reason:

To set the carburetor mixture screws for proper operation of the carburetor.

Equipment:

- JT07270 Pulse Tachometer

IMPORTANT: Avoid damage! In order to obtain correct operation of the carburetor, the adjustment procedure must be performed in the sequence shown.

Procedure:

IMPORTANT: Avoid damage! When servicing engine (when the engine is running), it is important to remove hood to avoid damage from muffler exhaust heat source.

1. Remove hood assembly. (See “Hood Removal and Installation” on page 313 in the Miscellaneous section.)
2. Start engine and run at 1/2 throttle for 5 minutes to bring engine to operating temperature.
3. Move throttle to idle position.