

Product: John Deere 4400 and 4500 Telescopic Handlers Service Repair Technical Manual
Full Download: <https://www.bobmanualstore.com/downloads/john-deere-4400-and-4500-telescopic-handlers-service-repair-technical-manual/>

4400 and 4500 Telescopic Handlers

DCEO-Mannheim
TM4541 (23JAN01)

Printed in Germany
ENGLISH

Sample manual. Download All 250 pages at:

<https://www.bobmanualstore.com/downloads/john-deere-4400-and-4500-telescopic-handlers-service-repair-technical-manu>

Introduction

FOREWORD

This manual is written for an experienced technician. Essential tools required in performing certain service work are identified in this manual and are recommended for use.

Live with safety: Read the safety messages in the introduction of this manual and the cautions presented throughout the text of the manual.



This is the safety-alert symbol. When you see this symbol on the machine or in this manual, be alert to the potential for personal injury.

Information is organized in groups for the various components requiring service instruction.

Technical Manuals are concise guides for specific machines. They are on-the-job guides containing only the vital information needed for diagnosis, analysis, testing, and repair.

Fundamental service information is available from other sources covering basic theory of operation, fundamentals of troubleshooting, general maintenance, and basic type of failures and their causes.

Contents

SECTION 05—Safety

Group 05—Safety Information

SECTION 50—Transmission

Group 00—General Information

Group 05—Removal and Replacement

Group 10—Disassembly and Assembly of the
Torque Converter Housing

Group 15—Disassembly and Assembly of the
Gearbox

Group 20—Disassembly and Assembly of the
Reverser Unit

Group 25—Disassembly and Assembly of the
Hydraulic 2/4 Wheel Drive Unit

SECTION 60—REMOVAL AND REPAIR OF AXLES AND BRAKES

Group 05—Front Axle Removal

Group 10—Rear Axle Removal

Group 15—Hydraulic Steering

Group 20—Cab - Steering Column

Group 25—Axles and Brakes - Brake Circuit

Group 30—Brakes

SECTION 70—HYDRAULIC SYSTEM

Group 00—General Information

Group 10—Hydraulic Pump

Group 20—Hydraulics - Priority Valve

Group 30—Hydraulics - Fault Finding

SECTION 80—CHASSIS AND BOOM

Group 05—Removal and Repair

SECTION 90—OPERATOR'S CAB

Group 00—Cab - Disassembly and Reassembly

Group 05—Cab Heater/Cab Seat - Removal

SECTION 240—ELECTRICAL SYSTEM

Group 05—System Information

Group 10—System Diagrams

Index

All information, illustrations and specifications in this manual are based on the latest information available at the time of publication. The right is reserved to make changes at any time without notice.

TM4541-19-23JAN01

COPYRIGHT© 1997
DEERE & COMPANY
European Office Mannheim
All rights reserved
A John Deere ILLUSTRATION® Manual

Contents

Section 05 Safety

Contents

Page

Group 05—Safety Information 05-05-1

Contents

Group 05 Safety Information

RECOGNIZE SAFETY INFORMATION

This is the safety-alert symbol. When you see this symbol on your machine or in this manual, be alert to the potential for personal injury.

Follow recommended precautions and safe operating practices.



DX,ALERT -19-03MAR93

T81389 -JUN-07DEC88

PREVENT MACHINE RUNAWAY

Avoid possible injury or death from machinery runaway.

Do not start engine by shorting across starter terminals. Machine will start in gear if normal circuitry is bypassed.

NEVER start engine while standing on ground. Start engine only from operator's seat, with transmission in neutral.



GS002

-JUN-18AUG95

GS,BYPAS1 -19-15JUL95

HANDLE FLUIDS SAFELY—AVOID FIRES

When you work around fuel, do not smoke or work near heaters or other fire hazards.

Store flammable fluids away from fire hazards. Do not incinerate or puncture pressurized containers.

Make sure machine is clean of trash, grease, and debris.

Do not store oily rags; they can ignite and burn spontaneously.



DX,FLAME -19-04JUN90

TS227 -JUN-23AUG88

Safety Information

PREPARE FOR EMERGENCIES

Be prepared if a fire starts.

Keep a first aid kit and fire extinguisher handy.

Keep emergency numbers for doctors, ambulance service, hospital, and fire department near your telephone.

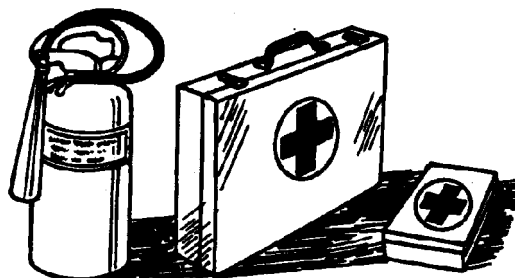

DX,FIRE2 -19-03MAR93

TS291
-JUN-23AUG88

PREVENT ACID BURNS

Sulfuric acid in battery electrolyte is poisonous. It is strong enough to burn skin, eat holes in clothing, and cause blindness if splashed into eyes.

Avoid the hazard by:

1. Filling batteries in a well-ventilated area.
2. Wearing eye protection and rubber gloves.
3. Avoiding breathing fumes when electrolyte is added.
4. Avoiding spilling or dripping electrolyte.
5. Use proper jump start procedure.

If you spill acid on yourself:

1. Flush your skin with water.
2. Apply baking soda or lime to help neutralize the acid.
3. Flush your eyes with water for 15—30 minutes. Get medical attention immediately.

If acid is swallowed:

1. Do not induce vomiting.
2. Drink large amounts of water or milk, but do not exceed 2 L (2 quarts).
3. Get medical attention immediately.

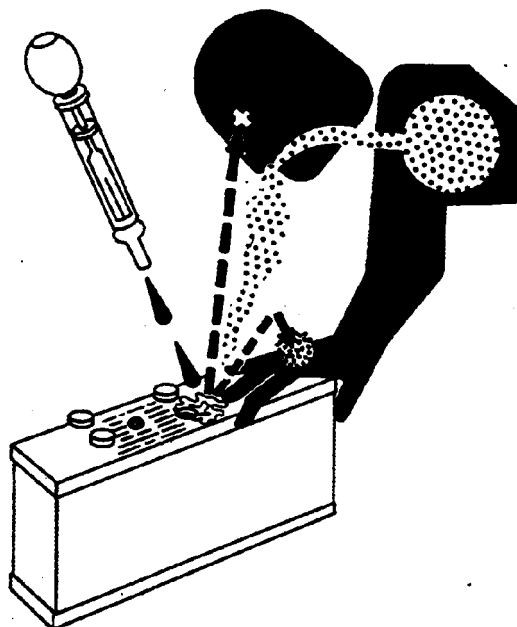

DX,POISON -19-21APR93

TS203
-JUN-23AUG88

Safety Information

AVOID HIGH-PRESSURE FLUIDS

Escaping fluid under pressure can penetrate the skin causing serious injury.

Avoid the hazard by relieving pressure before disconnecting hydraulic or other lines. Tighten all connections before applying pressure.

Search for leaks with a piece of cardboard. Protect hands and body from high pressure fluids.

If an accident occurs, see a doctor immediately. Any fluid injected into the skin must be surgically removed within a few hours or gangrene may result. Doctors unfamiliar with this type of injury should reference a knowledgeable medical source. Such information is available from Deere & Company Medical Department in Moline, Illinois, U.S.A.

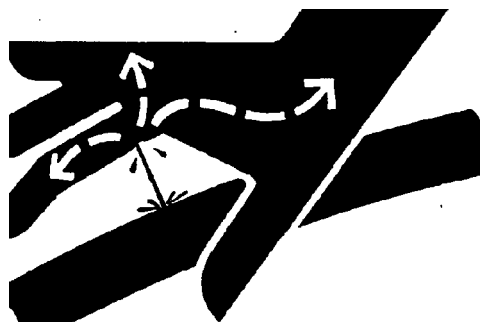

-UN-23AUG88

X9811

DX,FLUID -19-03MAR93

PARKING AND LEAVING THE MACHINE

Lower attachment or carriage to the ground before leaving the machine.

Shut off engine, select neutral with both the gear lever and the forward/reverse control.

Apply handbrake, remove main switch key and lock the operator's cab. Position chock blocks.

Never leave machine unattended as long as engine is still running.

Never leave the cab when driving.



LX002510

-UN-17JAN95

LX002510

GS,PARK -19-01SEP95

SUPPORT MACHINE PROPERLY

A raised boom can drop suddenly and cause serious injury. Before working under a raised boom, install a boom safety strut.

Do not support the machine on cinder blocks, hollow tiles, or props that may crumble under continuous load. Do not work under a machine that is supported solely by a jack. Follow recommended procedures in this manual.

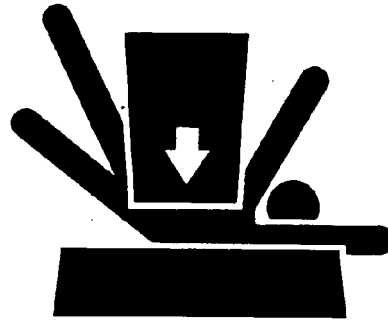

TSS229 -UN-23AUG88

GS,LOWER -19-01JUL95

WEAR PROTECTIVE CLOTHING

Wear close fitting clothing and safety equipment appropriate to the job.

Prolonged exposure to loud noise can cause impairment or loss of hearing.

Wear a suitable hearing protective device such as earmuffs or earplugs to protect against objectionable or uncomfortable loud noises.

Operating equipment safely requires the full attention of the operator. Do not wear radio or music headphones while operating machine.

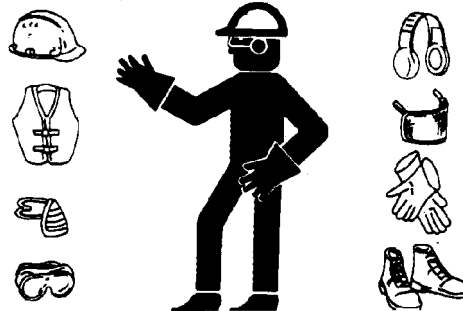

TSS206 -UN-23AUG88

DX,WEAR -19-10SEP90

WORK IN CLEAN AREA

Before starting a job:

- Clean work area and machine.
- Make sure you have all necessary tools to do your job.
- Have the right parts on hand.
- Read all instructions thoroughly; do not attempt shortcuts.

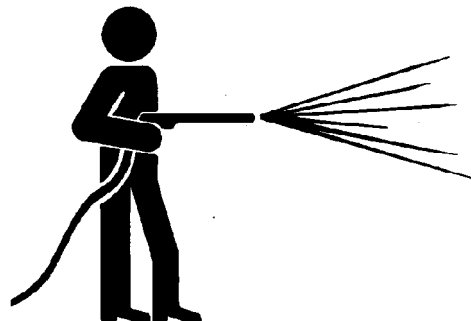

T6642EJ -UN-18OCT88

DX,CLEAN -19-04JUN90

Safety Information

SERVICE MACHINES SAFELY

Tie long hair behind your head. Do not wear a necktie, scarf, loose clothing, or necklace when you work near machine tools or moving parts. If these items were to get caught, severe injury could result.

Remove rings and other jewelry to prevent electrical shorts and entanglement in moving parts.

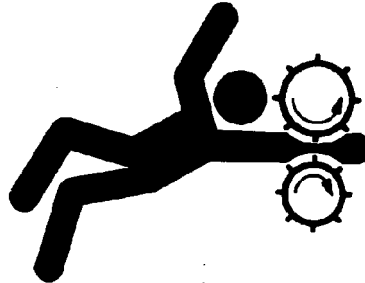

DX, LOOSE -19-04JUN90

TS228 -JUN-23AUG88

WORK IN VENTILATED AREA

Engine exhaust fumes can cause sickness or death. If it is necessary to run an engine in an enclosed area, remove the exhaust fumes from the area with an exhaust pipe extension.

If you do not have an exhaust pipe extension, open the doors and get outside air into the area.

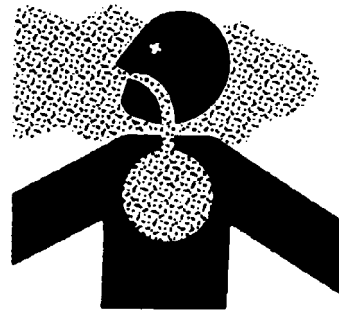

DX, AIR -19-04JUN90

TS220 -JUN-23AUG88

ILLUMINATE WORK AREA SAFELY

Illuminate your work area adequately but safely. Use a portable safety light for working inside or under the machine. Make sure the bulb is enclosed by a wire cage. The hot filament of an accidentally broken bulb can ignite spilled fuel or oil.

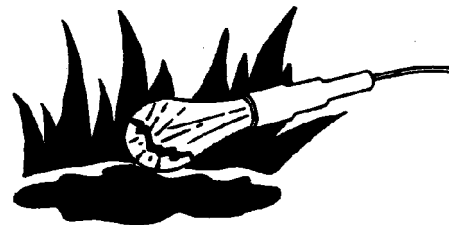

DX, LIGHT -19-04JUN90

TS223 -JUN-23AUG88

REPLACE SAFETY SIGNS

Replace missing or damaged safety signs. See the machine operator's manual for correct safety sign placement.

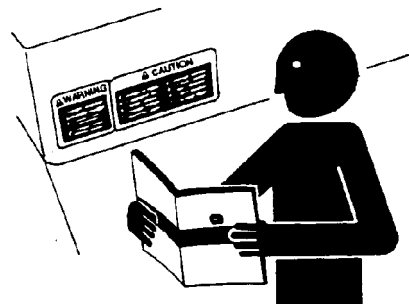

DX, SIGNS1 -19-04JUN90

TS201 -JUN-23AUG88

Safety Information

USE PROPER LIFTING EQUIPMENT

Lifting heavy components incorrectly can cause severe injury or machine damage.

Follow recommended procedure for removal and installation of components in the manual.

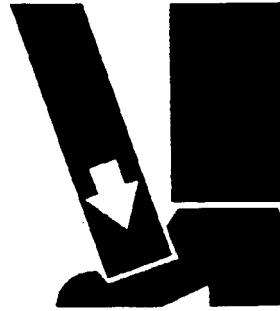

DX,LIFT -19-04JUN90

TS226 -UN-23AUG88

AVOID HEATING NEAR PRESSURIZED FLUID LINES

Flammable spray can be generated by heating near pressurized fluid lines, resulting in severe burns to yourself and bystanders. Do not heat by welding, soldering, or using a torch near pressurized fluid lines or other flammable materials. Pressurized lines can be accidentally cut when heat goes beyond the immediate flame area.



DX,TORCH -19-03MAR93

TS953 -UN-15MAY90

REMOVE PAINT BEFORE WELDING OR HEATING

Avoid potentially toxic fumes and dust.

Hazardous fumes can be generated when paint is heated by welding, soldering, or using a torch.

Do all work outside or in a well ventilated area. Dispose of paint and solvent properly.

Remove paint before welding or heating:

- If you sand or grind paint, avoid breathing the dust. Wear an approved respirator.
- If you use solvent or paint stripper, remove stripper with soap and water before welding. Remove solvent or paint stripper containers and other flammable material from area. Allow fumes to disperse at least 15 minutes before welding or heating.

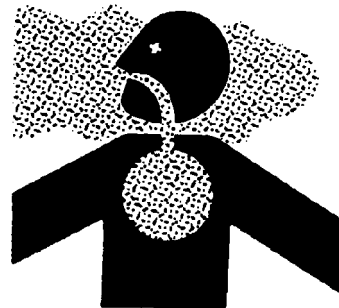

DX,PAINT -19-03MAR93

TS220 -UN-23AUG88

KEEP ROPS INSTALLED PROPERLY

Make certain all parts are reinstalled correctly if the roll-over protective structure (ROPS) is loosened or removed for any reason. Tighten mounting bolts to proper torque.

The protection offered by ROPS will be impaired if ROPS is subjected to structural damage, is involved in an overturn incident, or is in any way altered by welding, bending, drilling, or cutting. A damaged ROPS should be replaced, not reused.

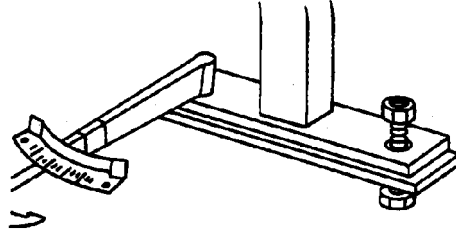

TS212
-JUN-23AUG88

DX,ROPS3 -19-03MAR93

SERVICE TIRES SAFELY

Explosive separation of a tire and rim parts can cause serious injury or death.

Do not attempt to mount a tire unless you have the proper equipment and experience to perform the job.

Always maintain the correct tire pressure. Do not inflate the tires above the recommended pressure. Never weld or heat a wheel and tire assembly. The heat can cause an increase in air pressure resulting in a tire explosion. Welding can structurally weaken or deform the wheel.

When inflating tires, use a clip-on chuck and extension hose long enough to allow you to stand to one side and NOT in front of or over the tire assembly. Use a safety cage if available.

Check wheels for low pressure, cuts, bubbles, damaged rims or missing lug bolts and nuts.

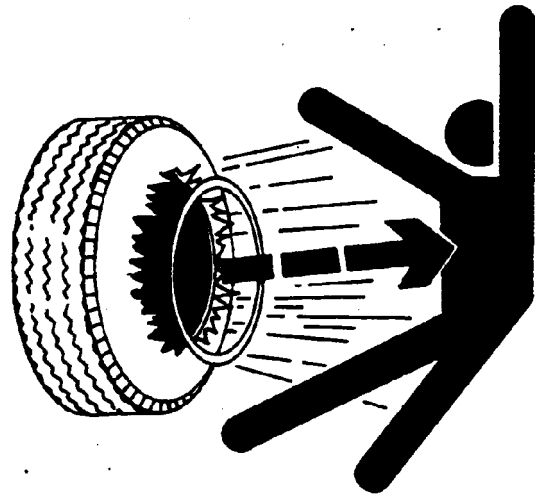

TS211
-JUN-23AUG88

DX,RIM -19-24AUG90

PRACTICE SAFE MAINTENANCE

Understand service procedure before doing work. Keep area clean and dry.

Never lubricate, service, or adjust machine while it is moving. Keep hands, feet, and clothing from power-driven parts. Disengage all power and operate controls to relieve pressure. Lower equipment to the ground. Stop the engine. Remove the key. Allow machine to cool.

Securely support any machine elements that must be raised for service work.

Keep all parts in good condition and properly installed. Fix damage immediately. Replace worn or broken parts. Remove any buildup of grease, oil, or debris.

Disconnect battery ground cable (-) before making adjustments on electrical systems or welding on machine.



TS218
-UN-23AUG88

DX,SERV -19-03MAR93

USE PROPER TOOLS

Use tools appropriate to the work. Makeshift tools and procedures can create safety hazards.

Use power tools only to loosen threaded parts and fasteners.

For loosening and tightening hardware, use the correct size tools. DO NOT use U.S. measurement tools on metric fasteners. Avoid bodily injury caused by slipping wrenches.

Use only service parts meeting John Deere specifications.



TS779
-UN-08NOV89

DX,REPAIR -19-04JUN90

DISPOSE OF WASTE PROPERLY

Improperly disposing of waste can threaten the environment and ecology. Potentially harmful waste used with John Deere equipment include such items as oil, fuel, coolant, brake fluid, filters, and batteries.

Use leakproof containers when draining fluids. Do not use food or beverage containers that may mislead someone into drinking from them.

Do not pour waste onto the ground, down a drain, or into any water source.

Air conditioning refrigerants escaping into the air can damage the Earth's atmosphere. Government regulations may require a certified air conditioning service center to recover and recycle used air conditioning refrigerants.

Inquire on the proper way to recycle or dispose of waste from your local environmental or recycling center, or from your John Deere dealer.

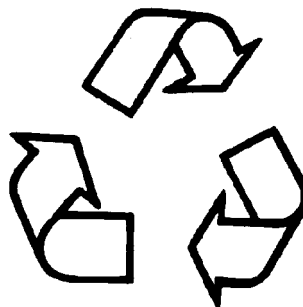

TS1133 -UN-26NOV90

DX,DRAIN -19-03MAR93

LIVE WITH SAFETY

Before returning machine to customer, make sure machine is functioning properly, especially the safety systems. Install all guards and shields.



TS231 -19-07OCT88

DX,LIVE -19-25SEP92

Safety Information

Section 50 Transmission

Contents

	Page	Page
Group 00—General Information		
Basic information	50-00-1	
Specifications	50-00-2	
Towing procedure	50-00-4	
Descriptions	50-00-5	
Synchronizer description	50-00-8	
Synchronizer operation	50-00-10	
Reverser clutch operation	50-00-11	
Clutch operation four-wheel drive	50-00-12	
Clutch operation front wheel drive	50-00-13	
Group 05—Removal and Replacement		
Removal and replacement of torque converter housing	50-05-1	
Removal and replacement of the gearbox	50-05-4	
Fitting procedure	50-05-5	
Group 10—Disassembly and Assembly of the Torque Converter Housing		
Disassembly of the torque converter housing	50-10-1	
Assembly of the torque converter housing	50-10-2	
Torque converter housing with PTO	50-10-3	
Torque converter stall test	50-10-5	
Pressure and flow test	50-10-8	
Group 15—Disassembly and Assembly of the Gearbox		
Disassembly of the gearbox	50-15-1	
Assembly of the gearbox	50-15-14	
Fault finding - gearbox	50-15-30	
Group 20—Disassembly and Assembly of the Reverser Unit		
Disassembly and assembly of the solenoid valve	50-20-1	
Disassembly of the reverser unit	50-20-2	
Assembly of the reverser unit	50-20-4	
Group 25—Disassembly and Assembly of the Hydraulic 2/4 Wheel Drive Unit		
Disassembly of the hydraulic 2/4 wheel drive unit	50-25-2	
		Assembly of the hydraulic 2/4 wheel drive unit 50-25-3
		Transmission testing 50-25-4
		Pressure and flow testing 50-25-5
		Pressure testing the 2/4 WD clutch 50-25-7
		Fault finding in the 2/4 wheel clutch 50-25-8
		Fault finding in the drive train 50-25-10

Contents

General Information/Specifications

SPECIFICATIONS

Item	Measurement	Specification
Converter		
Converter In at 50 °C;122 °F, 1000 rpm	Pressure (in Neutral)	240 to 340 kPa;2.4 to 3.4 bar;34.8 to 49.3 psi
Converter In at 50 °C;122 °F, 2000 rpm	Pressure (in Neutral)	70 to 620 kPa;0.7 to 6.2 bar;10.1 to 89.9 psi
Converter In at 100 °C;212 °F, 1000 rpm	Pressure (in Neutral)	130 to 200 kPa;1.3 to 2.0 bar;18.8 to 29 psi
Converter In at 100 °C;212 °F, 2000 rpm	Pressure (in Neutral)	520 to 590 kPa;5.2 to 5.9 bar;75.4 to 85.5 psi
Converter Out at 50 °C;122 °F, 1000 rpm	Pressure (in Neutral)	100 to 170 kPa;1.0 to 1.7 bar;14.5 to 26.6 psi
Converter Out at 50 °C;122 °F, 2000 rpm	Pressure (in Neutral)	0 to 210 kPa;0 to 2.1 bar;0 to 30.4 psi
Converter Out at 100 °C;212 °F, 1000 rpm	Pressure (in Neutral)	30 to 60 kPa;0.3 to 0.6 bar;4.3 to 8.7 psi
Converter Out at 100 °C;212 °F, 2000 rpm	Pressure (in Neutral)	100 to 170 kPa;1.0 to 1.7 bar;14.5 to 24.5 psi
Converter inlet relief valve	Pressure (max)	650 kPa;6.5 bar;94.2 psi
Lubrication Pressure		
At 50 °C;122 °F, 1000 rpm	Pressure (in Neutral)	20 to 30 kPa;0.2 to 0.3 bar;2.9 to 4.3 psi
At 50 °C;212 °F, 2000 rpm	Pressure (in Neutral)	40 to 70 kPa;0.4 to 0.7 bar;5.8 to 10.1 psi
At 100 °C;122 °F, 1000 rpm	Pressure (in Neutral)	10 to 20 kPa;0.1 to 0.2 bar;1.4 to 2.9 psi
At 100 °C;122 °F, 2000 rpm	Pressure (in Neutral)	30 to 60 kPa;0.3 to 0.6 bar;4.3 to 8.7 psi
Main Line Pressure		
At 50 °C;122 °F, 1000 rpm	Pressure (in Neutral)	930 to 1030 kPa;9.3 to 10.3 bar;134.8 to 149.4 psi

Continued on next page

General Information/Specifications

Item	Measurement	Specification
At 50 °C;122 °F, 2000 rpm	Pressure (in Neutral)	1070 to 1170 kPa;10.7 to 11.7 bar;155.2 to 169.7 psi
Full engine revs	Pressure (in Neutral)	1100 to 1240 kPa;11.0 to 12.4 bar;159.5 to 179.8 psi
At 100 °C;212 °F, 1000 rpm	Pressure (in Neutral)	930 to 1030 kPa;9.3 to 10.3 bar;134.8 to 149.4 psi
At 100 °C;212 °F, 2000 rpm	Pressure (in Neutral)	930 to 1030 kPa;9.3 to 10.3 bar;134.8 to 149.4 psi
Clutch Pressure		
At 50 °C;122 °F, 1000 rpm	Pressure (forward and reverse)	550 to 620 kPa;5.5 to 6.2 bar;79.7 to 89.9 psi
At 50 °C;122 °F, 2000 rpm	Pressure (forward and reverse)	760 to 960 kPa;7.6 to 9.6 bar;110.2 to 139.2 psi
At 100 °C;212 °F, 1000 rpm	Pressure (forward and reverse)	550 to 630 kPa;5.5 to 6.3 bar;79.7 to 91.4 psi
At 100 °C;212 °F, 2000 rpm	Pressure (forward and reverse)	620 to 690 kPa;6.2 to 6.9 bar;89.9 to 100.0 psi
Clutch Pressure		
At 50 °C;122 °F, 1000 rpm	Pressure (to disconnect 4 wheel drive)	860 to 930 kPa;8.6 to 9.3 bar;124.7 to 134.8 psi
At 50 °C;122 °F, 2000 rpm	Pressure (to disconnect 4 wheel drive)	860 to 930 kPa;8.6 to 9.3 bar;124.7 to 134.8 psi
Flow Rates Torque Converter Housing-with Hydraulic Pump Drive		
Cooler at 50 °C;122 °F, 1000 rpm	Flow rate	12.38 to 16.19 L/min;3.33 to 4.28 US gal/min
Cooler at 50 °C;122 °F, 2000 rpm	Flow rate	17.26 to 23.80 L/min;4.52 to 6.31 US gal/min
Cooler at 100 °C;212 °F, 1000 rpm	Flow rate	12.14 to 14.88 L/min;3.21 to 3.93 US gal/min
Cooler at 100 °C;212 °F, 2000 rpm	Flow rate	27.02 to 31.07 L/min;7.14 to 8.21 US gal/min
Continued on next page		

General Information/Towing procedure

Item	Measurement	Specification
Pump at 50 °C;122 °F, 1000 rpm	Flow rate	13.09 to 17.85 L/min;3.45 to 4.76 US gal/min
Pump at 50 °C;122 °F, 2000 rpm	Flow rate	26.78 to 35.12 L/min;7.14 to 9.28 US gal/min

NOTE: The forward/reverse clutch pressures should be same as mainline pressure to within 70 kPa;0.7 bar;10.1 psi.

GS4400.3 -19-01FEB97

TOWING PROCEDURE

If there is no damage, the machine may be towed for a distance of approximately 1.5 kilometers (1 mile). Always use a rigid tow bar, ensure that the gear lever is in neutral. Restrict towing speed to 25 km/h (15 mph).

If it is necessary to tow the machine for a distance in excess of 1.5 kilometers (1 mile), the axle drive shafts should be disconnected to prevent damage to the transmission system.

IMPORTANT: Removal or disconnection of the axle drive shaft(s) will disable the parking brake. It is essential that the following procedure be adopted.

Position the machine on firm level ground and block the wheels securely to prevent any movement. Select neutral and release the parking brake.

Disconnect the rear drive shaft(s) from the axle(s), and tie up the shaft securely well clear of the rotating axle yoke. Alternatively remove the shaft(s) completely.

Connect the towing vehicle via the tow bar before removing the blocks from the wheels. Restrict the towing speed to 25 km/h (15 mph).

When towing is complete, block the wheels securely before removing the tow bar and reconnecting the drive shafts.

IMPORTANT: In some countries neither of the procedures described above may be legally acceptable for towing on public highways.

GS4400.4 -19-01FEB97

General Information/Descriptions

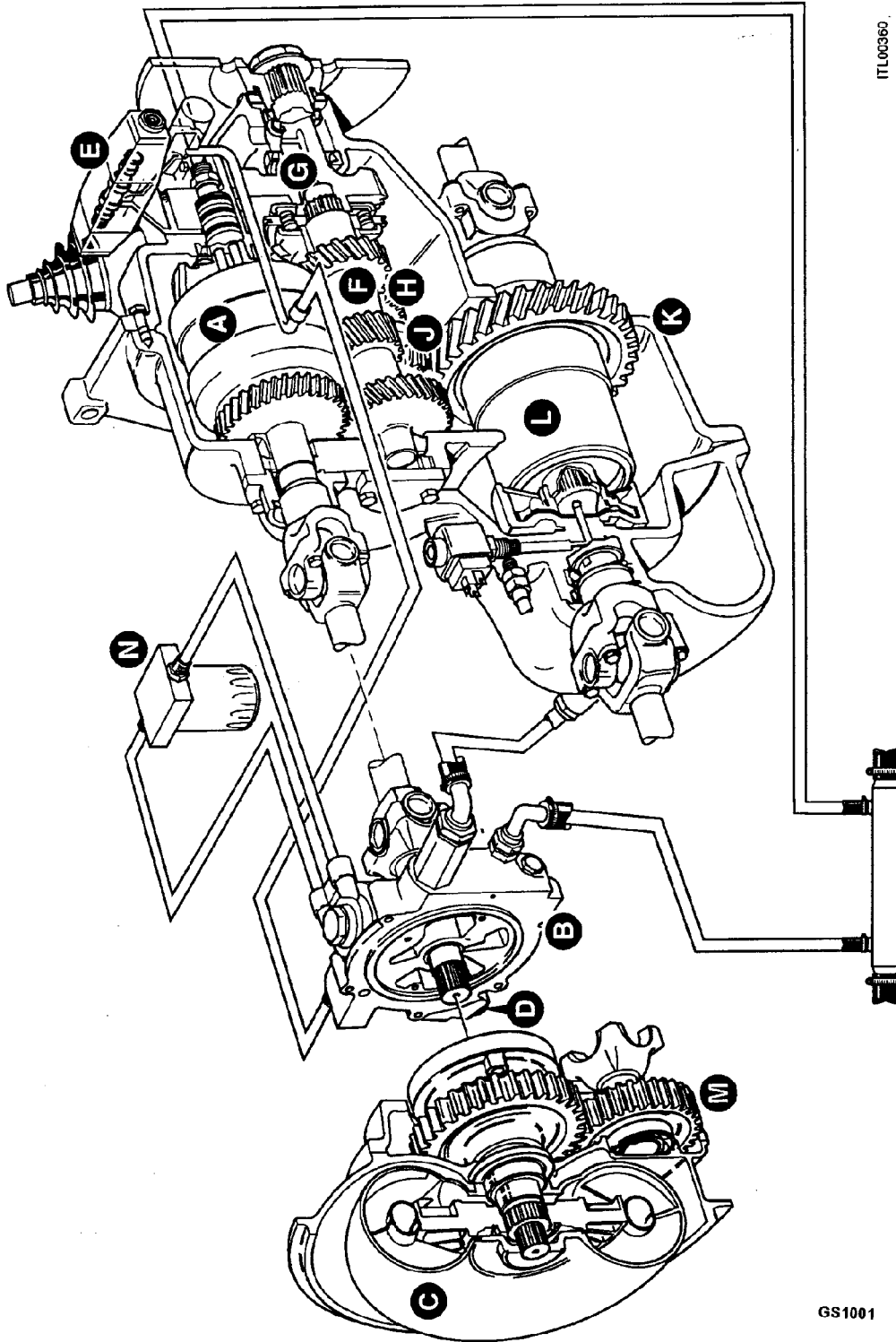

ITL00360

-UN-26MAR97

GS1001

GS1001

GS4400.5 -19-01FEB97

TM4541 (23JAN01)

50-00-5

4400 and 4500 Telescopic Handlers

230101
PN=18

GENERAL DESCRIPTION AND OPERATION

A—Reverser unit
B—Crescent-type pump
C—Torque converter
D—Pressure maintenance valve

E—Solenoid valve
F—Main shaft
G—3rd/4th synchronesh unit

H—Countershaft
J—1st/2nd synchronesh unit
K—Output gear

L—Clutch
M—Hydraulic pump drive
N—Remote oil filter

The transmission consists of a torque converter, mounted on the engine, and a separately mounted drop gearbox. The gearbox comprises a hydraulic reverser unit, 4-speed synchronesh gear system and a four-wheel drive clutch assembly.

The reverser unit (A) consists of a pair of hydraulically operated drive clutches giving forward-neutral-reverse drive. Oil pressure is provided by a crescent-type pump (B) which is driven at engine speed by the drive lugs of the torque converter (C). The oil pressure is controlled by maintenance valve (D) and clutch selection is achieved by means of solenoid valve (E). See "Reverser Clutch Operation" in this Group for further information on the reverser unit.

Drive is transferred from the reverser unit by helical gears to the mainshaft (F), which carries the 3rd/4th synchronesh unit (G), and to the countershaft (H), which carries the 1st/2nd synchronesh unit (J). The synchronesh units are of the blocking pin type.

Drive is finally transmitted from the countershaft (H) via the output gear (K) to both axles. In two-wheel drive a hydraulically operated clutch (L) disconnects the drive from the rear axle.

NOTE: The illustration shows a torque converter housing which incorporates an auxiliary hydraulic pump drive and utilises a remote oil filter (N).

General Information/Descriptions

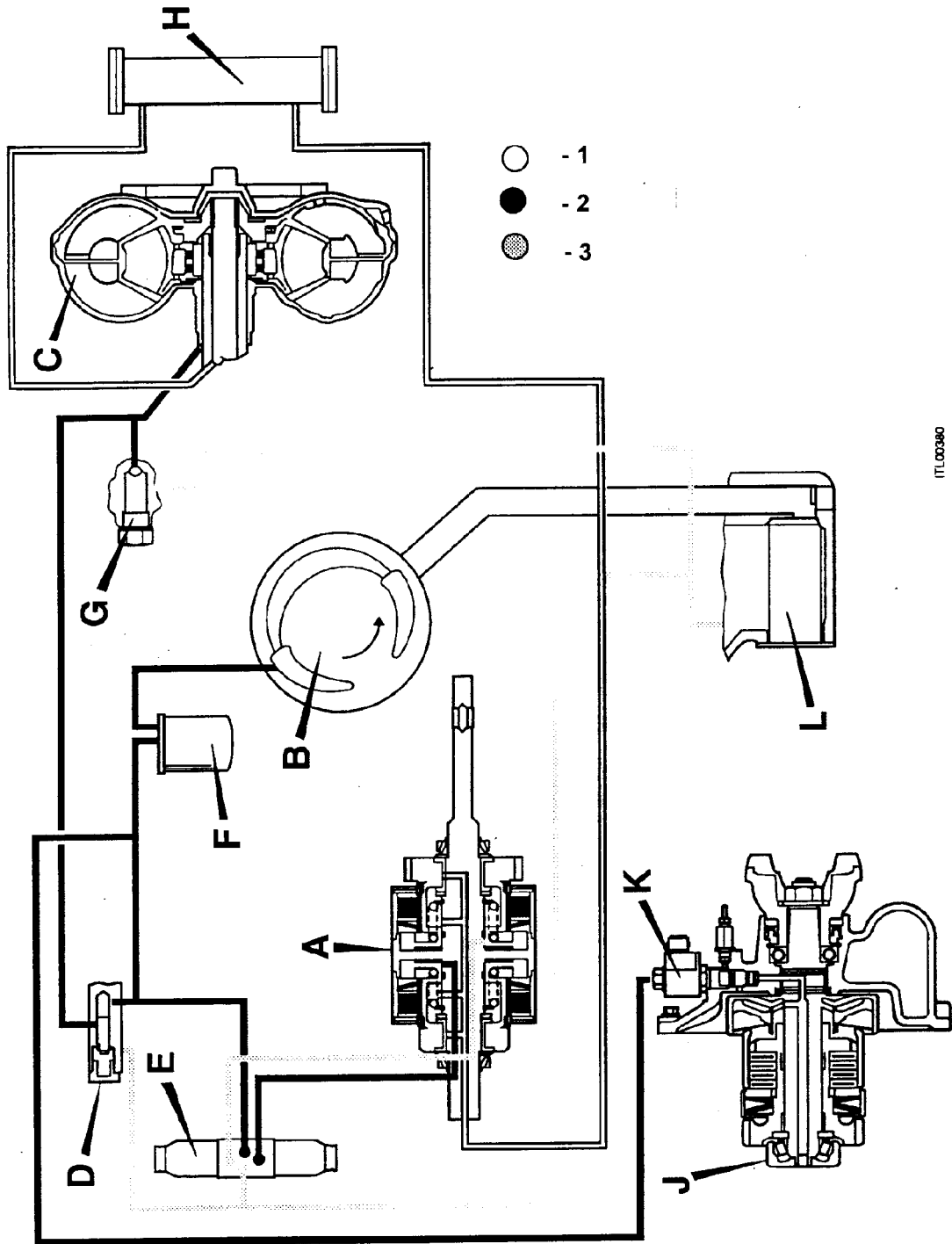

ITL00380

-JUN-26MAR97

GS1002

GS4400.7 -19-01FEB97

SCHEMATIC HYDRAULIC FLOW DIAGRAM (4WD CLUTCH, SPRING ON/PRESSURE OFF)

- | | | | |
|---------------------------------|---------------------------|---|-----------------------|
| A—Reverser unit | E—Solenoid valve | J—4WD clutch (spring ON/
pressure OFF) | 1—Lubrication circuit |
| B—Crescent type pump | F—Oil filter | K—Solenoid valve | 2—Pressurised circuit |
| C—Torque converter | G—Relief valve | L—Sump with suction
strainer | 3—Return circuit |
| D—Pressure maintaining
valve | H—Oil cooler (water type) | | |

GS4400,8 -19-01FEB97

SYNCHRONIZER DESCRIPTION

The gearbox is fitted with blocking pin synchromesh, comprising the following parts:

Syncho Hub (A) controls the operation of the synchromesh unit and gear selection, the selector fork fitting into the outer groove. Internal dog teeth link the selected gear to the drive shaft. Through the syncho hub center are two sets of holes for the blocker pins (C) and the split energiser pin (D), spaced alternately.

Syncho rings (B) are rigidly joined by the blocker pins, with the split energiser pins held, in counterbores, between the two syncho rings.

Blocker pins (C) have a narrow neck in the center, against which the syncho hub transmits radial drive during gear changes. The edges of the blocker pin neck and their mating syncho hub holes are designed so that, as the radial loads are reduced, the syncho hub can slide over the shoulder of the blocker pin.

Split energiser pins (D) take the initial axial load of the syncho hub on the shoulder of the split energiser pin neck. As the axial load reaches approximately 400 N (40.8 kg; 90lb) the internal springs allow the split energiser pin to collapse and the syncho hub to move axially.

Syncho cups (E) take the frictional drive from the syncho ring on their inner faces. The syncho cups are splined to drive their respective gears while synchronisation is taking place.

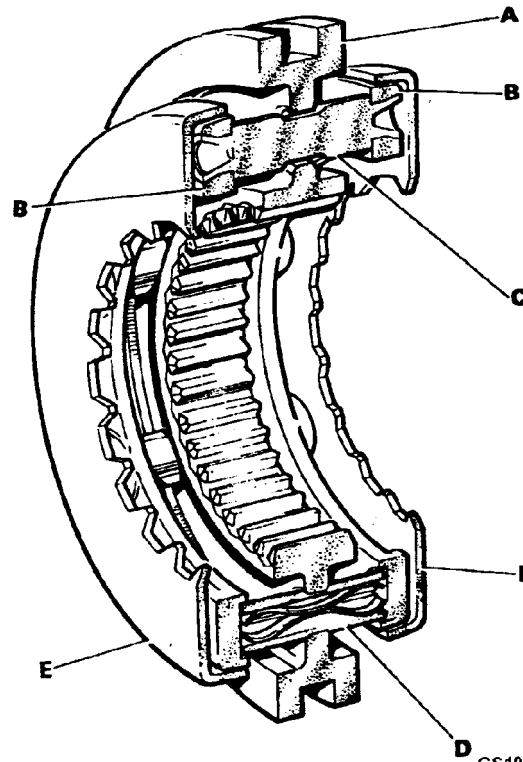

-JUN-26MAR97
GS1007

GS4400,9 -19-01FEB97

General Information/Synchronizer description

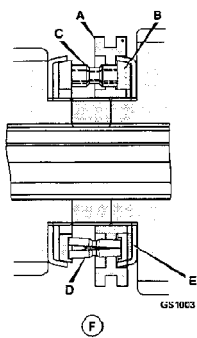

GS1003 -JUN-26MAR97

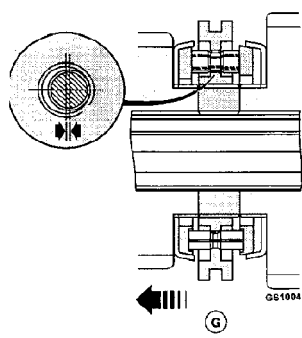

GS1004 -JUN-26MAR97

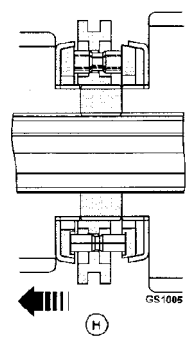

GS1005 -JUN-26MAR97

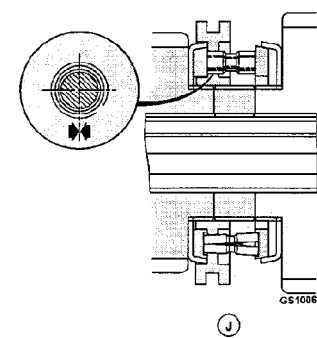

GS1006 -JUN-26MAR97

A—Synchro hub
B—Synchro ring

C—Blocker pins

D—Split energiser pins

E—Synchro cup

GS4400,10 -19-01FEB97

SYNCHRONIZER OPERATION

Diagram (F) shows the gearbox with first gear engaged. Synchro ring (B) is in contact with synchro cup (E) and the synchro hub dog teeth are linking first gear to the shaft gear. In this position the split energiser pins (D) are collapsed.

When selecting second gear the synchro hub (A) slides along the split energiser pins until the pin recess and the synchro hub flange are in line. At this point the split energiser pins open and the synchro rings are moved by the synchro hub pushing on the split energiser pin shoulder.

Initial contact between the synchro ring and the synchro cup starts to synchronise the speed of the shaft and second gear. The rotational force of the synchro ring is taken by the block pin against the edge of the synchro hub hole, as at (G).

As the axial load on the synchro hub increases, the split energiser pin collapses and the conical faces of the blocking pin and synchro hub hole come into contact, as at (H).

Further increases in the axial loads increase the frictional grip of the synchro ring and the synchro cup, causing the shaft and gear speeds to synchronise.

As the speeds are synchronised, the radial load on the blocker pin and the synchro hub is reduced. This allows the synchro hub to slide freely along the blocker pin and engage its dog teeth with second gear, see diagram (J).

FORWARD/REVERSE DRIVE CLUTCH OPERATION

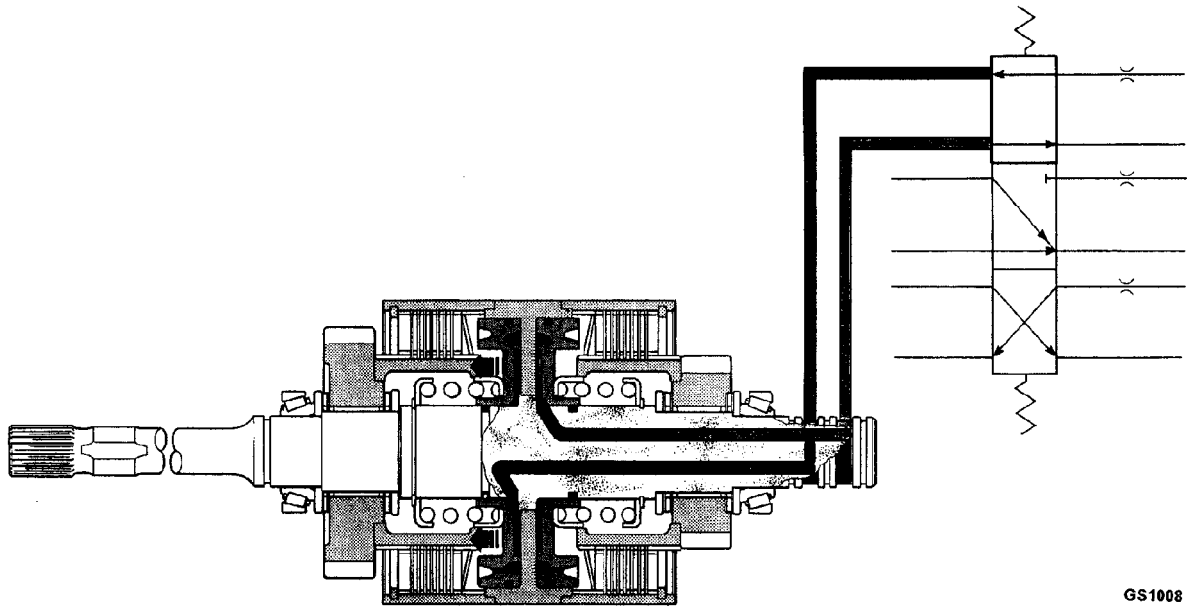

In neutral, the flow of pressurised oil to the clutches is blocked by the solenoid valve. When either forward or reverse is selected, the solenoid valve diverts pressurised oil via the reverser shaft to the

appropriate clutch in the reverser unit. Pressure from the other clutch is vented to the sump via the solenoid valve spool.

GS1008

JUN-26/MAR97
GS1008

GS4400.11 -19-01FEB97

General Information/Clutch operation four-wheel drive

CLUTCH OPERATION FOUR-WHEEL DRIVE

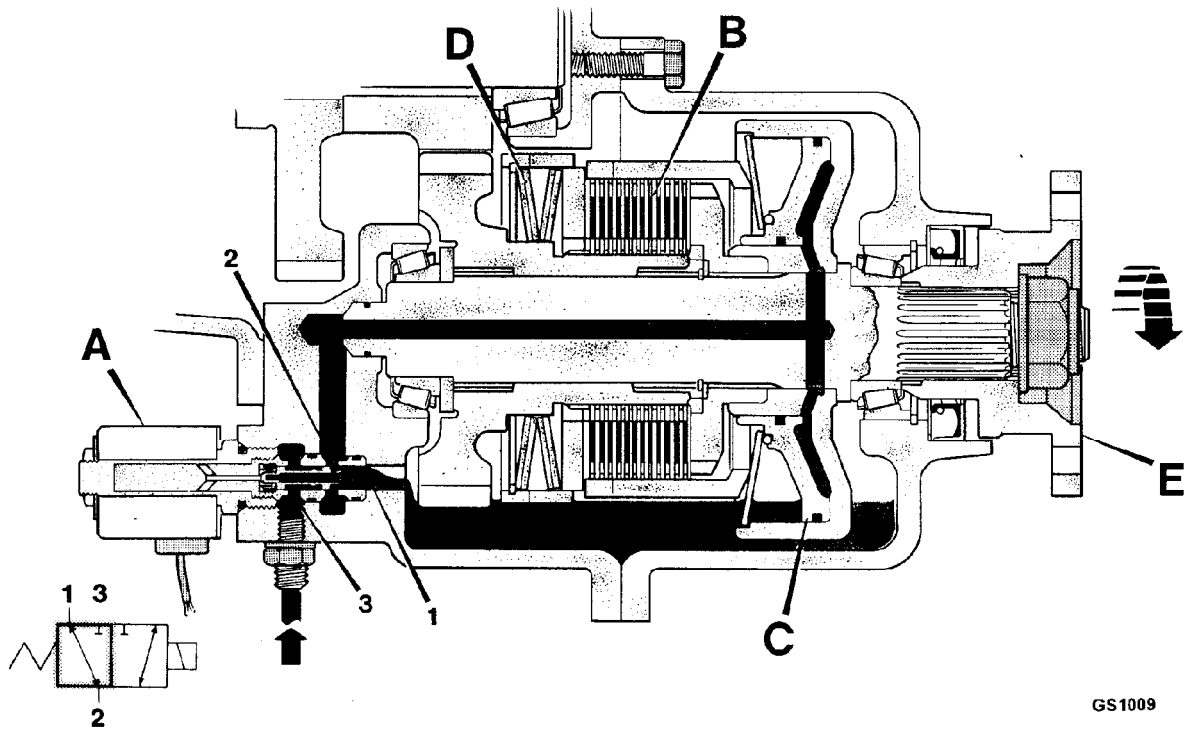

A—Solenoid valve
 B—Clutch friction/counter plates

C—Piston

D—Disk springs

E—Drive output flange

Four-wheel drive switched ON

The clutch is engaged and disengaged by introducing or dumping pressurised oil behind piston (C) via a solenoid valve (A). The solenoid valve is controlled by a toggle switch inside the cab.

When the toggle switch is in the 4 wheel drive position, solenoid valve (A) is de-energised, the oil supply to the piston (C) is blocked (shown at port 3).

The solenoid valve in the de-energised position also vents oil from the back of piston (C) to the sump via ports 1 and 2.

Because there is no pressure behind piston (C), clutch friction/counter plates (B) are forced together by disk springs (D), thus driving 4 wheel drive output flange (E).

GS1009

-JUN-26/MAR97
GS1009

GS4400,12 -19-01FEB97