

Product: John Deere 8100,8200,8300,8400 8110, 8210,8310,8410 Tractors Service Repair Technical Manual

Full Download: <https://www.bobmanualstore.com/downloads/john-deere-81008200>

8300,8400,8110-8210,8310,8410-tractors-service-repair-technical
-manual/

8100, 8200, 8300, 8400 8110, 8210, 8310, 8410 Tractors Repair



D C G

TECHNICAL MANUAL 8100, 8200, 8300, 8400 8110, 8210, 8310, 8410 Tractors Repair TM1575 21JAN03 (ENGLISH)

For complete service information also see:

8100, 8200, 8300, and 8400 Tractors:	
- Operation and Test	TM1576
6076 Engines	CTM42
6081 Engines:	
- Repair	CTM86
- Operation and Test	CTM134
Engine Fuel Injection	CTM68
Starting Motors and Alternators	CTM77
8110, 8210, 8310 and 8410 Tractors:	
- Operation and Test	TM1797
- Diagnostics	TM1796

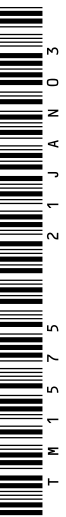

T M 1 5 7 5
2 1 J A N 0 3

John Deere Waterloo Works
LITHO IN U.S.A.

Sample manual. Download All 1124 pages at:

<https://www.bobmanualstore.com/downloads/john-deere-8100820083008400-8110-821083108410-tractors-service-repair-technical>

Introduction

Foreword

This manual is written for an experienced technician. Essential and recommended tools required in performing certain service work are identified in this manual.

Live with safety: Read the safety messages in the introduction of this manual and the cautions presented throughout the text of the manual.

 This is the safety-alert symbol. When you see this symbol on the machine or in this manual, be alert to the potential for personal injury.

Technical manuals are used to provide service information. The Repair Technical Manual tells how to repair the components. The Operation and Test Technical Manual helps you quickly identify the majority of failures.

Information is organized in groups for the various components requiring service instruction. At the beginning of each group are summary listings of all applicable essential and recommended tools, other material needed to do the job, service parts kits, specifications, wear tolerances, and torque values.

Technical manuals are concise guides for specific machines. They are on-the-job guides containing only the vital information needed for diagnosis, analysis, testing, and repair.

Fundamental service information is available from other sources covering basic theory of operation, fundamentals of troubleshooting, general maintenance, and basic type of failures and their causes.

RX,TMIFC -19-03APR96-1/1

Notice to the Dealer

This is a complete revision of TM1575 Repair Technical Manual for 8100, 8200, 8300, 8400, 8110, 8210, 8310 and 8410 Tractors.

Discard TM1575 dated 15NOV99

AG,RX15494,46 -19-24NOV98-1/1

Sample manual. Download All 1124 pages at:

<https://www.bobmanualstore.com/downloads/john-deere-8100820083008400-8110-821083108410-tractors-service-repair-technical>
TM1575 (21JAN03)

8100-8400 and 8110-8410 Tractors

012103
PN=2

Dealer Predelivery Service

The John Deere delivery receipt, when properly filled out and signed by the dealer and customer, verifies predelivery and delivery services were satisfactorily performed. When delivering the tractor, give the customer his copy of the delivery receipt and operators manual. Be sure to explain their purposes to him.

Because of the shipping factors involved, plus extra finishing touches necessary to promote customer satisfaction, there are certain predelivery services that must be performed by the dealer. These services are listed in the first of two sections on the predelivery

form which is attached to the tractor. The second section is a list of factory inspections that must be verified by the dealer.

Fill the form out completely and sign it. Send a copy to the factory and file the original with the shop order for the job. This will certify the proper delivery service has been completed.

Perform all services listed and check each job off as it is completed.

RX14581015,1 -19-09OCT90-1/1

Introduction

Contents

SECTION 10—General Information

- Group 05—Safety
- Group 10—General Information

SECTION 20—Engine

- Group 00—Component Removal and Installation
- Group 05—Engine Repair

SECTION 30—Fuel and Cooling Systems

- Group 05—Diesel Fuel System
- Group 10—Air Intake System
- Group 15—Engine Cooling System
- Group 20—Air Conditioning Condenser and Coolers

SECTION 40—Electrical

- Group 05—Connectors
- Group 10—Wiring Harness Routings
- Group 15—Charging Circuit
- Group 20—Starting Circuit
- Group 25—Solenoids and Switches
- Group 30—Monitoring Systems and Sensors
- Group 35—Armrest Control
- Group 40—Implement and Accessory Connectors
- Group 45—Convenience and Accessory Components

SECTION 50—Power Shift Transmission

- Group 00—Component Removal and Installation
- Group 05—Miscellaneous Repair
- Group 10—8100, 8200, 8300, and 8400 Transmission
- Group 15—8110, 8210, 8310, and 8410 Transmission

SECTION 56—Drive Systems

- Group 00—Component Removal and Installation
- Group 05—Rear Differential and Input Quill
- Group 10—Final Drives
- Group 15—Rear PTO
- Group 20—Hydraulic Pump Drive
- Group 25—MFWD Clutch
- Group 30—MFWD Axle—Version “A”
- Group 35—MFWD Axle—Version “B”
- Group 40—Drivelines

SECTION 60—Steering and Brakes

- Group 05—Steering Column
- Group 10—Steering Control Assembly
- Group 15—Steering Cylinders
- Group 20—Brake Valve
- Group 25—Brake Components
- Group 30—Trailer Brakes

SECTION 70—Hydraulics

- Group 00—Component Removal and Installation
- Group 05—Hydraulic System Repair and Cleanup
- Group 10—Tandem Hydraulic Pump (Steering-Brakes-Charge)
- Group 15—Secondary Hydraulic Pump (Hitch-SCV)
- Group 20—Filter Bypass
- Group 25—Hitch Valve, Selective Control Valves, and Couplers
- Group 30—Hitch
- Group 35—Row Guidance

SECTION 80—Miscellaneous

- Group 00—Component Removal and Installation
- Group 05—Front Axle (2-Wheel Drive)
- Group 10—Wagon and Pick-Up Hitch

SECTION 90—Operator Station

- Group 00—Component Removal and Installation
- Group 05—Heating, Ventilating and Air Conditioning—(HVAC)
- Group 10—Air Conditioning System
- Group 15—Air Suspension Seat (8000 Series)
- Group 20—Air Suspension Seat (8000 TEN Series)
- Group 25—Armrest
- Group 30—Cab Door and Windshield

SECTION 99—Dealer Fabricated Tools

- Group 05—Fabricated Tools

All information, illustrations and specifications in this manual are based on the latest information available at the time of publication. The right is reserved to make changes at any time without notice.

COPYRIGHT © 2003
DEERE & COMPANY
Moline, Illinois
All rights reserved
A John Deere ILLUSTRATION® Manual
Previous Editions
Copyright © 1996, 1995, 1994, 1998, 1999, 2000

Contents

10

20

30

40

50

56

60

70

80

90

Contents

99

INDX

Contents

99

INDX

Section 10 General Information

Contents

	Page
Group 05—Safety	10-05-1
Group 10—General Information	
General Specifications	10-10-1
Overall Dimensions	10-10-4
Sealants and Adhesives Cross-Reference	
Chart	10-10-5
Metric Bolt and Cap Screw Torque Values	10-10-6
Unified Inch Bolt and Cap Screw Torque	
Values	10-10-7
Glossary of Terms	10-10-8

Recognize Safety Information

This is a safety-alert symbol. When you see this symbol on your machine or in this manual, be alert to the potential for personal injury.

Follow recommended precautions and safe operating practices.



T81389 -UN-07DEC88

DX,ALERT -19-29SEP98-1/1

Handle Fluids Safely—Avoid Fires

When you work around fuel, do not smoke or work near heaters or other fire hazards.

Store flammable fluids away from fire hazards. Do not incinerate or puncture pressurized containers.

Make sure machine is clean of trash, grease, and debris.

Do not store oily rags; they can ignite and burn spontaneously.



TS227 -UN-23AUG88

DX,FLAME -19-29SEP98-1/1

Prevent Battery Explosions

Keep sparks, lighted matches, and open flame away from the top of battery. Battery gas can explode.

Never check battery charge by placing a metal object across the posts. Use a volt-meter or hydrometer.

Do not charge a frozen battery; it may explode. Warm battery to 16°C (60°F).



TS204 -UN-23AUG88

DX,SPARKS -19-03MAR93-1/1

Prepare for Emergencies

Be prepared if a fire starts.

Keep a first aid kit and fire extinguisher handy.

Keep emergency numbers for doctors, ambulance service, hospital, and fire department near your telephone.

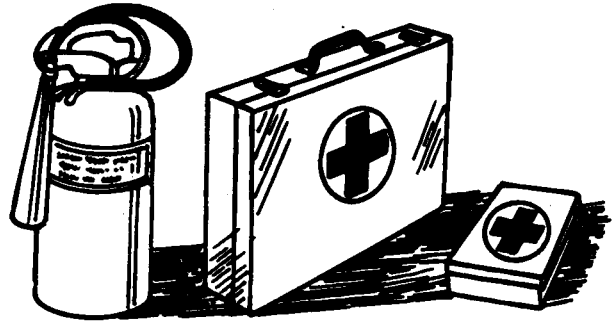

TS291 -UN-23AUG88

DX,FIRE2 -19-03MAR93-1/1

Prevent Acid Burns

Sulfuric acid in battery electrolyte is poisonous. It is strong enough to burn skin, eat holes in clothing, and cause blindness if splashed into eyes.

Avoid the hazard by:

1. Filling batteries in a well-ventilated area.
2. Wearing eye protection and rubber gloves.
3. Avoiding breathing fumes when electrolyte is added.
4. Avoiding spilling or dripping electrolyte.
5. Use proper jump start procedure.

If you spill acid on yourself:

1. Flush your skin with water.
2. Apply baking soda or lime to help neutralize the acid.
3. Flush your eyes with water for 15—30 minutes. Get medical attention immediately.

If acid is swallowed:

1. Do not induce vomiting.
2. Drink large amounts of water or milk, but do not exceed 2 L (2 quarts).
3. Get medical attention immediately.

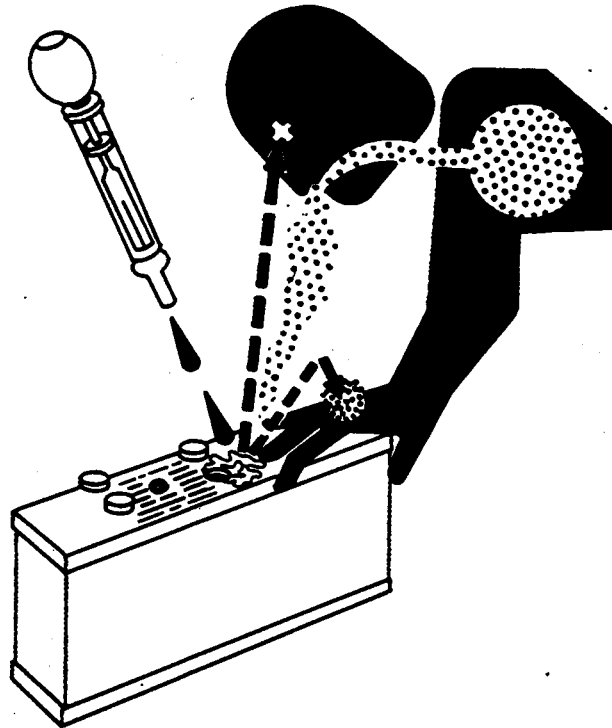

TS203 -UN-23AUG88

DX,POISON -19-21APR93-1/1

Handle Chemical Products Safely

Direct exposure to hazardous chemicals can cause serious injury. Potentially hazardous chemicals used with John Deere equipment include such items as lubricants, coolants, paints, and adhesives.

A Material Safety Data Sheet (MSDS) provides specific details on chemical products: physical and health hazards, safety procedures, and emergency response techniques.

Check the MSDS before you start any job using a hazardous chemical. That way you will know exactly what the risks are and how to do the job safely. Then follow procedures and recommended equipment.

(See your John Deere dealer for MSDS's on chemical products used with John Deere equipment.)

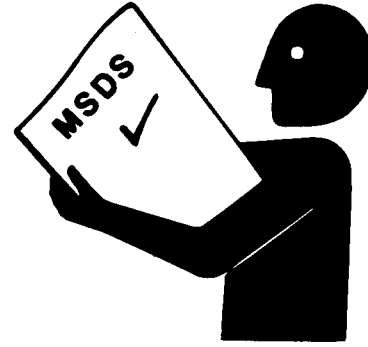

TS1132 -UN-26NOV90

DX,MSDS,NA -19-03MAR93-1/1

Avoid High-Pressure Fluids

Escaping fluid under pressure can penetrate the skin causing serious injury.

Avoid the hazard by relieving pressure before disconnecting hydraulic or other lines. Tighten all connections before applying pressure.

Search for leaks with a piece of cardboard. Protect hands and body from high pressure fluids.

If an accident occurs, see a doctor immediately. Any fluid injected into the skin must be surgically removed within a few hours or gangrene may result. Doctors unfamiliar with this type of injury should reference a knowledgeable medical source. Such information is available from Deere & Company Medical Department in Moline, Illinois, U.S.A.

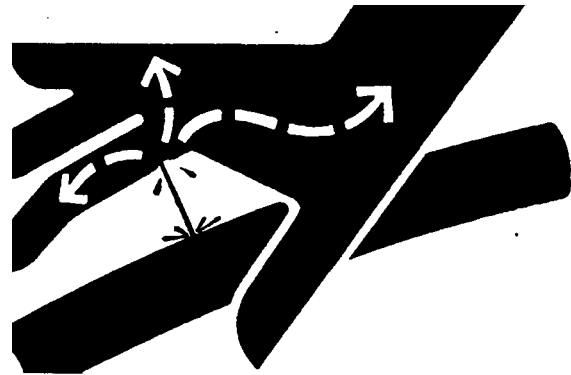

X9811 -UN-23AUG88

DX,FLUID -19-03MAR93-1/1

Park Machine Safely

Before working on the machine:

- Lower all equipment to the ground.
- Stop the engine and remove the key.
- Disconnect the battery ground strap.
- Hang a "DO NOT OPERATE" tag in operator station.

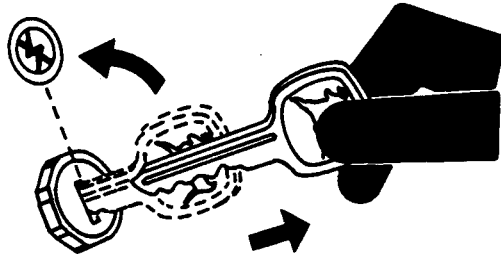

TS230 -JUN-24MAY89

DX,PARK -19-04JUN90-1/1

Support Machine Properly

Always lower the attachment or implement to the ground before you work on the machine. If the work requires that the machine or attachment be lifted, provide secure support for them. If left in a raised position, hydraulically supported devices can settle or leak down.

Do not support the machine on cinder blocks, hollow tiles, or props that may crumble under continuous load. Do not work under a machine that is supported solely by a jack. Follow recommended procedures in this manual.

When implements or attachments are used with a machine, always follow safety precautions listed in the implement or attachment operator's manual.

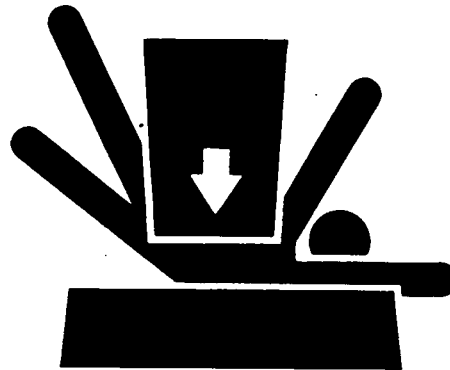

TS229 -JUN-23AUG88

DX,LOWER -19-24FEB00-1/1

Wear Protective Clothing

Wear close fitting clothing and safety equipment appropriate to the job.

Prolonged exposure to loud noise can cause impairment or loss of hearing.

Wear a suitable hearing protective device such as earmuffs or earplugs to protect against objectionable or uncomfortable loud noises.

Operating equipment safely requires the full attention of the operator. Do not wear radio or music headphones while operating machine.

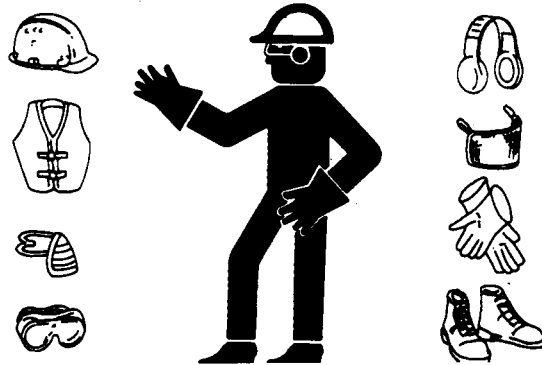

TS206 -JUN-23AUG88

DX,WEAR -19-10SEP90-1/1

Work in Clean Area

Before starting a job:

- Clean work area and machine.
- Make sure you have all necessary tools to do your job.
- Have the right parts on hand.
- Read all instructions thoroughly; do not attempt shortcuts.

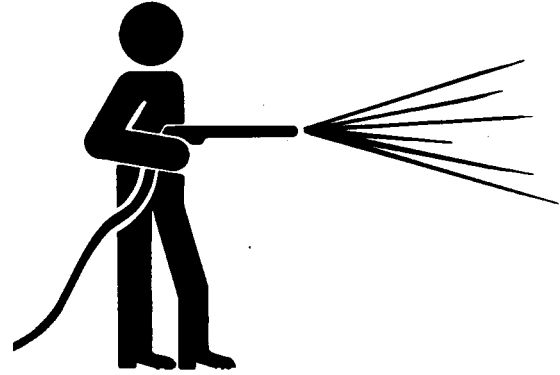

T6642EJ -UN-18OCT88

DX,CLEAN -19-04JUN90-1/1

Service Machines Safely

Tie long hair behind your head. Do not wear a necktie, scarf, loose clothing, or necklace when you work near machine tools or moving parts. If these items were to get caught, severe injury could result.

Remove rings and other jewelry to prevent electrical shorts and entanglement in moving parts.

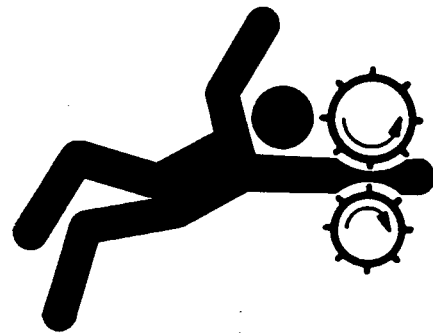

TS228 -UN-23AUG88

DX,LOOSE -19-04JUN90-1/1

Work In Ventilated Area

Engine exhaust fumes can cause sickness or death. If it is necessary to run an engine in an enclosed area, remove the exhaust fumes from the area with an exhaust pipe extension.

If you do not have an exhaust pipe extension, open the doors and get outside air into the area

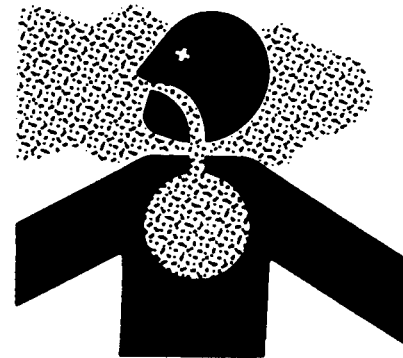

TS220 -UN-23AUG88

DX,AIR -19-17FEB99-1/1

Illuminate Work Area Safely

Illuminate your work area adequately but safely. Use a portable safety light for working inside or under the machine. Make sure the bulb is enclosed by a wire cage. The hot filament of an accidentally broken bulb can ignite spilled fuel or oil.



TS223 -UN-23AUG88

DX,LIGHT -19-04JUN90-1/1

10
05
6

Replace Safety Signs

Replace missing or damaged safety signs. See the machine operator's manual for correct safety sign placement.



DX,SIGNS1 -19-04JUN90-1/1

TS201 -UN-23AUG88

Use Proper Lifting Equipment

Lifting heavy components incorrectly can cause severe injury or machine damage.

Follow recommended procedure for removal and installation of components in the manual.

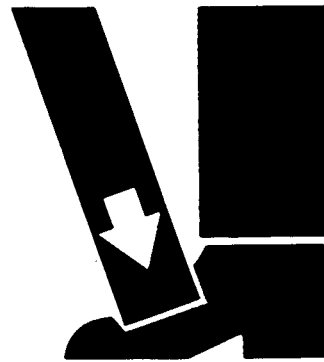

DX,LIFT -19-04JUN90-1/1

TS226 -UN-23AUG88

Avoid Harmful Asbestos Dust

Avoid breathing dust that may be generated when handling components containing asbestos fibers. Inhaled asbestos fibers may cause lung cancer.

Components in products that may contain asbestos fibers are brake pads, brake band and lining assemblies, clutch plates, and some gaskets. The asbestos used in these components is usually found in a resin or sealed in some way. Normal handling is not hazardous as long as airborne dust containing asbestos is not generated.

Avoid creating dust. Never use compressed air for cleaning. Avoid brushing or grinding material containing asbestos. When servicing, wear an approved respirator. A special vacuum cleaner is recommended to clean asbestos. If not available, apply a mist of oil or water on the material containing asbestos.

Keep bystanders away from the area.

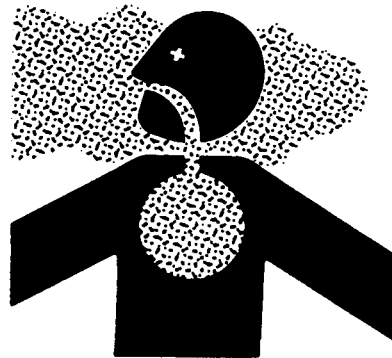

DX,DUST -19-15MAR91-1/1

TS220 -UN-23AUG88

Avoid Heating Near Pressurized Fluid Lines

Flammable spray can be generated by heating near pressurized fluid lines, resulting in severe burns to yourself and bystanders. Do not heat by welding, soldering, or using a torch near pressurized fluid lines or other flammable materials. Pressurized lines can be accidentally cut when heat goes beyond the immediate flame area.



TS963 -UN-15MAY90

DX,TORCH -19-03MAR93-1/1

Remove Paint Before Welding or Heating

Avoid potentially toxic fumes and dust.

Hazardous fumes can be generated when paint is heated by welding, soldering, or using a torch.

Remove paint before heating:

- Remove paint a minimum of 76 mm (3 in.) from area to be affected by heating.
- If you sand or grind paint, avoid breathing the dust. Wear an approved respirator.
- If you use solvent or paint stripper, remove stripper with soap and water before welding. Remove solvent or paint stripper containers and other flammable material from area. Allow fumes to disperse at least 15 minutes before welding or heating.

Do all work in an area that is ventilated to carry toxic fumes and dust away.

Dispose of paint and solvent properly.

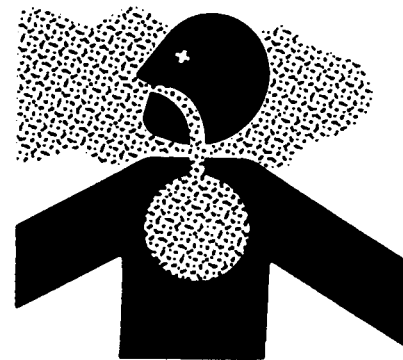

TS220 -UN-23AUG88

DX,PAINT -19-22OCT99-1/1

10
05
8

Use Proper Tools

Use tools appropriate to the work. Makeshift tools and procedures can create safety hazards.

Use power tools only to loosen threaded parts and fasteners.

For loosening and tightening hardware, use the correct size tools. DO NOT use U.S. measurement tools on metric fasteners. Avoid bodily injury caused by slipping wrenches.

Use only service parts meeting John Deere specifications.



TS779 -UN-08NOV89

DX,REPAIR -19-17FEB99-1/1

Construct Dealer-Made Tools Safely

Faulty or broken tools can result in serious injury. When constructing tools, use proper, quality materials, and good workmanship.

Do not weld tools unless you have the proper equipment and experience to perform the job.

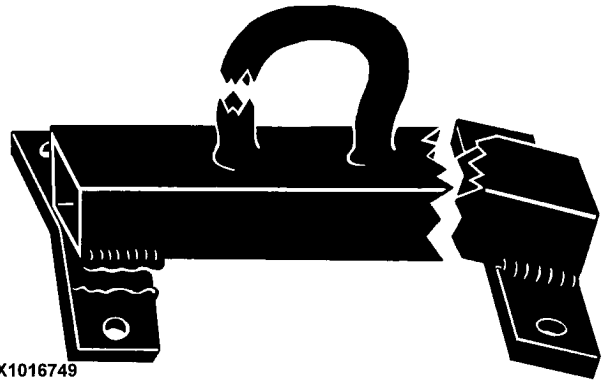

LX1016749

LX1016749 -UN-01JUL97

DX,SAFE,TOOLS -19-10OCT97-1/1

Dispose of Waste Properly

Improperly disposing of waste can threaten the environment and ecology. Potentially harmful waste used with John Deere equipment include such items as oil, fuel, coolant, brake fluid, filters, and batteries.

Use leakproof containers when draining fluids. Do not use food or beverage containers that may mislead someone into drinking from them.

Do not pour waste onto the ground, down a drain, or into any water source.

Air conditioning refrigerants escaping into the air can damage the Earth's atmosphere. Government regulations may require a certified air conditioning service center to recover and recycle used air conditioning refrigerants.

Inquire on the proper way to recycle or dispose of waste from your local environmental or recycling center, or from your John Deere dealer.

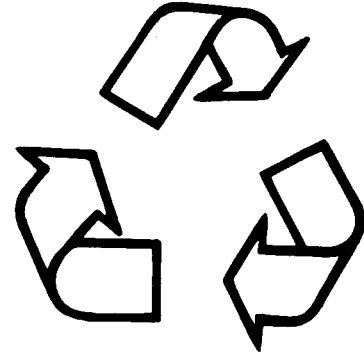

TS1133 -UN-26NOV90

DX,DRAIN -19-03MAR93-1/1

Live With Safety

Before returning machine to customer, make sure machine is functioning properly, especially the safety systems. Install all guards and shields.



TS231 -19-07OCT88

DX,LIVE -19-25SEP92-1/1

10
05
10

General Specifications

	8100-8110	8200-8210	8300-8310	8400-8410
Power (Factory Observed):				
PTO (8000 Series)	119 kW (160 hp)	134 kW (180 hp)	149 kW (200 hp)	168 kW (225 hp)
.. (8000 TEN Series)	123 kW (165 hp)	138 kW (185 hp)	153 kW (205 hp)	175 kW (235 hp)
Rated Speed	2200 rpm	2200 rpm	2200 rpm	2200 rpm
Engine Speed at PTO				
Operating Speed:				
.. 1000 rpm	2200 rpm	2200 rpm	2200 rpm	2200 rpm
.. 540 rpm	1930 rpm	1930 rpm	1930 rpm	1930 rpm
Governed Speed Range	800—2400 rpm	800—2400 rpm	800—2400 rpm	800—2400 rpm
Operating Speed Range	1500—2200 rpm	1500—2200 rpm	1500—2200 rpm	1500—2200 rpm
Slow Idle Speed	790—810 rpm	790—810 rpm	790—810 rpm	790—810 rpm
Fast Idle Speed	2275—2325 rpm	2275—2325 rpm	2275—2325 rpm	2275—2325 rpm
Engine:				
Type	Diesel	Diesel	Diesel	Diesel
Cylinders	In-line 6	In-line 6	In-line 6	In-line 6
Aspiration	Turbocharged and Air-to-Air Aftercooled	Turbocharged and Air-to-Air Aftercooled	Turbocharged and Air-to-Air Aftercooled	Turbocharged and Air-to-Air Aftercooled
Lubrication	Full-Flow Filtration with Bypass	Full-Flow Filtration with Bypass	Full-Flow Filtration with Bypass	Full-Flow Filtration with Bypass
P.I.N. (—010000):				
Displacement	7.6 L (466 in. ³)	7.6 L (466 in. ³)	7.6 L (466 in. ³)	8.1 L (496 in. ³)
Bore	116 mm (4.56 in.)	116 mm (4.56 in.)	116 mm (4.56 in.)	116 mm (4.56 in.)
Stroke	121 mm (4.75 in.)	121 mm (4.75 in.)	121 mm (4.75 in.)	128.5 mm (5.06 in.)
Compression Ratio	15.0:1	15.0:1	15.0:1	15.8:1
Valve Clearance:				
.. Intake	0.38 mm (0.015 in.)	0.38 mm (0.015 in.)	0.38 mm (0.015 in.)	0.46 mm (0.018 in.)
.. Exhaust	0.51 mm (0.020 in.)	0.51 mm (0.020 in.)	0.51 mm (0.020 in.)	0.71 mm (0.028 in.)
P.I.N. (010001—):				
Displacement	8.1 L (496 in. ³)	8.1 L (496 in. ³)	8.1 L (496 in. ³)	8.1 L (496 in. ³)
Bore	116 mm (4.56 in.)	116 mm (4.56 in.)	116 mm (4.56 in.)	116 mm (4.56 in.)
Stroke	128.5 mm (5.06 in.)	128.5 mm (5.06 in.)	128.5 mm (5.06 in.)	128.5 mm (5.06 in.)
Compression Ratio	16.5:1	16.5:1	16.5:1	16.5:1
Valve Clearance:				
.. Intake	0.46 mm (0.018 in.)	0.46 mm (0.018 in.)	0.46 mm (0.018 in.)	0.46 mm (0.018 in.)
.. Exhaust	0.71 mm (0.028 in.)	0.71 mm (0.028 in.)	0.71 mm (0.028 in.)	0.71 mm (0.028 in.)
Electrical System:				
Type	12 Volt	12 Volt	12 Volt	12 Volt
Alternator	140 amp	140 amp	140 amp	140 amp
Batteries	2	2	2	2
Cold Cranking Amps	1850	1850	1850	1850

Continued on next page

AG,OURX113,7 -19-04NOV99-1/3

General Information

10
10
2

Capacities:

Fuel Tank	512 L (135 gal)	512 L (135 gal)	512 L (135 gal)	512 L (135 gal)
Cooling System:				
.. P.I.N. (—010000)	27.2 L (7.2 gal)	27.2 L (7.2 gal)	27.2 L (7.2 gal)	28.4 L (7.5 gal)
.. P.I.N. (010000—)	34.0 L (9 gal)	34.0 L (9 gal)	34.0 L (9 gal)	34.0 L (9 gal)
Crankcase	21.5 L (5.7 gal)	23.5 L (6.2 gal)	25.0 L (6.6 gal)	27.0 L (7.1 gal)
Transmission and Hydraulics	140 L (37 gal) ^a	140 L (37 gal) ^a	140 L (37 gal) ^a	140 L (37 gal) ^a
MFWD Differential	10.9 L (2.9 gal)	10.9 L (2.9 gal)	10.9 L (2.9 gal)	10.9 L (2.9 gal)
MFWD Wheel Hubs	3 L (3.2 qt)	3 L (3.2 qt)	3 L (3.2 qt)	3 L (3.2 qt)

^aIncludes 22.7 L (6 gal) for Clean-Oil Reservoir

Cooling System:

Type 70 kPa (0.7 bar) (10 psi) Liquid with Gear-Driven Centrifugal Pump and Enclosed Recovery Tank
 Fan – P.I.N. (—010000) Viscous Drive – Gear-Driven
 Fan – P.I.N. (010001—) Viscous Drive – Belt-Driven
 Thermostats Two Heavy-Duty

Fuel System:

Injection Pump Type In-Line with Electronic Governor
 Fuel Filter Standard Clamp-On Final Filter with Optional Spin-On Primary Filter with Water Separator Bowl
 Air Cleaner Dry-Type with Secondary Element

Hydraulic System:

Type Pressure/Flow Compensated
 Tandem Gear Pump (Steering-Brakes-Charge):
 .. Maximum Pressure 20 000 kPa (2900 psi)
 .. Rated Flow at Charge Pump (8000 Series) 1.8 L/s (28 gpm)
 (8000 TEN Series) 2.0 L/s (31 gpm)
 .. Rated Flow at Primary Pump (8000 Series) 1.3 L/s (21 gpm)
 (8000 TEN Series) 1.4 L/s (23 gpm)
 Secondary Axial Piston Pump (Hitch-SCV)
 .. Available Flow (45 cm³) (8000 Series) 1.9 L/s (30 gpm)
 (8000 TEN Series) 2.1 L/s (33.5 gpm)
 .. Available Flow (Optional 57 cm³) (8000 Series) 2.4 L/s (38 gpm)
 (8000 TEN Series) 2.7 L/s (42.5 gpm)
 Available Flow at SCVs 1.9 L/s (30 gpm)
 Hitch Lift Capacity:
 .. Standard:
 8100, 8110, 8200, 8210 4717 kg (10400 lb)
 8300, 8310, 8400, 8410 5307 kg (11700 lb)
 .. Optional:
 8100, 8110, 8200, 8210 6425 kg (14165 lb)
 8300, 8310, 8400, 8410 7099 kg (15650 lb)

Continued on next page

AG.OURX113.7 –19–04NOV99–2/3

General Information

10
10
3

Brakes:

Type Power Hydraulic Wet Disk

Steering:

Type Hydrostatic Power

Turns (Lock-to-Lock) 3.7

Transmission:

16-Speed Powershift:

.. Type Electronically Activated Wet Clutch

.. Gear Selections 16 Forward – 4 Reverse

.. Automatic PowerShift Standard on 8000 TEN Series

Power Take Off:

Type Fully Independent

Size:

.. Standard 45 mm (1-3/4 in.) 1000 rpm

.. Optional 45 mm (1-3/4 in.) 1000 rpm with Reversible Adapter for 35 mm (1-3/8 in.) 1000 rpm or 35 mm (1-3/8 in.) 540 rpm

Clutch Multiple Wet-Disk Hydraulically Activated

Weight:

Average Shipping Weight 2-Wheel Drive with Cab and 18.4R46 Rear and 11.00-24 Front Tires:

.. 8100, 8110 7470 kg (16435 lb)

.. 8200, 8210 7480 kg (16457 lb)

.. 8300, 8310 7741 kg (17030 lb)

Average Shipping Weight MFWD with Cab and 18.4R46 Rear and 14.9R34 Front Tires:

.. 8100, 8110 8125 kg (17876 lb)

.. 8200, 8210 8135 kg (17898 lb)

.. 8300, 8310 8419 kg (18523 lb)

.. 8400, 8410 (16.9R30 Front Tires) 8504 kg (18709 lb)

AG.OURX113.7 -19-04NOV99-3/3

General Information

10
10
4

Overall Dimensions

	8100-8110	8200-8210	8300-8310	8400-8410
Overall Dimensions:				
Wheelbase:				
.. Two-Wheel Drive	3120 mm (122.8 in.)	3120 mm (122.8 in.)	3120 mm (122.8 in.)	—
.. MFWD	2950 mm (116.1 in.)	2950 mm (116.1 in.)	2950 mm (116.1 in.)	2950 mm (116.1 in.)
Overall Length ^a	5246 mm (206.5 in.)	5246 mm (206.5 in.)	5246 mm (206.5 in.)	5246 mm (206.5 in.)
Width:				
.. Standard Axle	3012 mm (118.5 in.)	3012 mm (118.5 in.)	3012 mm (118.5 in.)	3012 mm (118.5 in.)
.. Optional Axle (8000 Series)	2750 mm (110.5 in.)	2750 mm (110.5 in.)	2750 mm (110.5 in.)	2750 mm (110.5 in.)
.. Optional (8000 TEN Series)	2750 mm (110.5 in.)	2750 mm (110.5 in.)	—	—
Axle Diameter:				
.. Standard	100 mm (3-15/16 in.)	100 mm (3-15/16 in.)	110 mm (4-5/16 in.)	110 mm (4-5/16 in.)
.. Optional (8000 Series)	110 mm (4-5/16 in.)	110 mm (4-5/16 in.)	100 mm (3-15/16 in.)	100 mm (3-15/16 in.)
.. Optional (8000 TEN Series)	110 mm (4-5/16 in.)	110 mm (4-5/16 in.)	—	—
Height:				
.. Top of Cab (8000 Series)	3005 mm (118.3 in.)	3005 mm (118.3 in.)	3053 mm (120.2 in.)	3053 mm (120.2 in.)
.... (8000 TEN Series)	3053 mm (120.2 in.)	3053 mm (120.2 in.)	3053 mm (120.2 in.)	3053 mm (120.2 in.)
Crop Clearance:				
.. Front Axle—2WD	700 mm (27.5 in.)	700 mm (27.5 in.)	802 mm (31.5 in.)	—
.. Front Axle—MFWD	590 mm (23.2 in.)	590 mm (23.2 in.)	590 mm (23.2 in.)	590 mm (23.2 in.)
.. Rear Axle Housing (8000)	753 mm (29.6 in.)	753 mm (29.6 in.)	802 mm (31.5 in.)	802 mm (31.5 in.)
.... (8000 TEN Series)	802 mm (31.5 in.)	802 mm (31.5 in.)	802 mm (31.5 in.)	802 mm (31.5 in.)
.. Drawbar Clearance (8000)	343 mm (15.5 in.)	343 mm (15.5 in.)	442 mm (17.4 in.)	442 mm (17.4 in.)
.... (8000 TEN Series)	442 mm (17.4 in.)	442 mm (17.4 in.)	442 mm (17.4 in.)	442 mm (17.4 in.)
Turning Radius: ^b				
.. Two-Wheel Drive	4.9 m (16.2 ft)	4.9 m (16.2 ft)	4.9 m (16.2 ft)	—
.. MFWD	5.3 m (17.55 ft)	5.3 m (17.55 ft)	5.3 m (17.55 ft)	5.3 m (17.55 ft)

^aExcludes Hitch and Drawbar

^bMFWD Disengaged and Without Brakes

AG.OURX113.6 -19-04NOV99-1/1

Sealants and Adhesives Cross-Reference Chart

U.S. PART NUMBER	CANADIAN PART NUMBER	COLOR	SIZE	DESCRIPTION	LOCTITE NUMBER	SIMILAR LOCTITE PRODUCT
Bonding						
TY15435	TY15702	BLACK & WHITE	4 gm	Epoxy Adhesive	445	453
TY21517	TY16173	CLEAR	3 gm	Instant Gel Adhesive	454	416, 409, or 495
Gasketing						
T43514	TY9475	RED	50 ml	Rigid Form-in-Place Gasket	277	568
TY6304	TY9484	PURPLE	50 ml	Flexible Form-in-Place Gasket	515	518
TY15934	—	BROWN	16 oz	General Purpose Gasket Dressing	—	Permatex #3
TY16100	TY6337	BROWN	4 oz	General Purpose Gasket Dressing	—	Permatex #3
TY16021	TY16112	BLUE	50 ml	High-Flex Form-in-Place Gasket	17430	—
TY16099	TY16113	BURGUNDY	16 oz	High Tack Gasket Dressing	—	Permatex #98
TY16135	TY15705	SILVER BLUE	3 oz	Ultra Blue RTV Silicone Form-in-Place Gasket	587	Permatex #77
Priming						
TY16285	TY9485	GREEN	4.5 oz	Cure Primer	7649	—
Retaining						
TY8311	TY15801	SILVER	50 ml	Quick Metal ^a Press Fit	660	—
TY15969 ^b	TY16040	GREEN	50 ml	Maximum Strength	680	635
TY15941	TY16039	GREEN	50 ml	High-Temperature	620	—
^a QUICK METAL is a trademark of Loctite Corporation						
^b TY15969 replaces T43515						
Threadlocking and Threadsealing						
T43512	TY9473	BLUE	50 ml	Medium Strength	242	241 or 243
TY9370	TY9477	BLUE	6 ml	Medium Strength	242	241 or 243
T43513	TY9474	CLEAR	50 ml	High Strength	271	262 or 609
TY9371	TY9478	CLEAR	6 ml	High Strength	271	262 or 609
TY9374	TY9481	WHITE	6 ml	Pipe Sealant with TEFLON [®]	592	565 or 567
TY9375	TY9480	WHITE	50 ml	Pipe Sealant with TEFLON [®]	592	565 or 567

TEFLON is a registered trademark of DuPont Company

TEFLON is a registered trademark of Du Pont Co.

AG.OURX113,17 -19-16FEB00-1/1

Metric Bolt and Cap Screw Torque Values

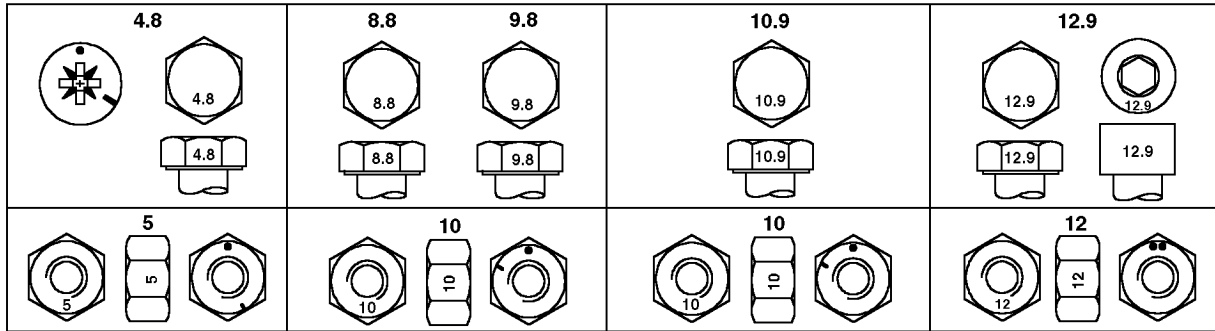

Top, Property Class and Head Markings; Bottom, Property Class and Nut Markings

Size	Class 4.8		Class 8.8 or 9.8		Class 10.9		Class 12.9	
	Lubricated ^a N•m(lb-ft)	Dry ^b N•m(lb-ft)	Lubricated ^a N•m(lb-ft)	Dry ^b N•m(lb-ft)	Lubricated ^a N•m(lb-ft)	Dry ^b N•m(lb-ft)	Lubricated ^a N•m(lb-ft)	Dry ^b N•m(lb-ft)
M6	4.7 (3.5)	6 (4.4)	9 (6.6)	11.5 (8.5)	13 (9.5)	16.5 (12.2)	15.5 (11.5)	19.5 (14.5)
M8	11.5 (8.5)	14.5 (10.7)	22 (16)	28 (20.5)	32 (23.5)	40 (29.5)	37 (27.5)	47 (35)
M10	23 (17)	29 (21)	43 (32)	55 (40)	63 (46)	80 (59)	75 (55)	95 (70)
M12	40 (29.5)	50 (37)	75 (55)	95 (70)	110 (80)	140 (105)	130 (95)	165 (120)
M14	63 (46)	80 (59)	120 (88)	150 (110)	175 (130)	220 (165)	205 (150)	260 (190)
M16	100 (74)	125 (92)	190 (140)	240 (175)	275 (200)	350 (255)	320 (235)	400 (300)
M18	135 (100)	170 (125)	265 (195)	330 (245)	375 (275)	475 (350)	440 (325)	560 (410)
M20	190 (140)	245 (180)	375 (275)	475 (350)	530 (390)	675 (500)	625 (460)	790 (580)
M22	265 (195)	330 (245)	510 (375)	650 (480)	725 (535)	920 (680)	850 (625)	1080 (800)
M24	330 (245)	425 (315)	650 (480)	820 (600)	920 (680)	1150 (850)	1080 (800)	1350 (1000)
M27	490 (360)	625 (460)	950 (700)	1200 (885)	1350 (1000)	1700 (1250)	1580 (1160)	2000 (1475)
M30	660 (490)	850 (625)	1290 (950)	1630 (1200)	1850 (1350)	2300 (1700)	2140 (1580)	2700 (2000)
M33	900 (665)	1150 (850)	1750 (1300)	2200 (1625)	2500 (1850)	3150 (2325)	2900 (2150)	3700 (2730)
M36	1150 (850)	1450 (1075)	2250 (1650)	2850 (2100)	3200 (2350)	4050 (3000)	3750 (2770)	4750 (3500)

^a "Lubricated" means coated with a lubricant such as engine oil, or fasteners with phosphate and oil coatings.

^b "Dry" means plain or zinc plated without any lubrication.

DO NOT use these values if a different torque value or tightening procedure is given for a specific application. Torque values listed are for general use only. Check tightness of fasteners periodically.

Shear bolts are designed to fail under predetermined loads. Always replace shear bolts with identical property class.

Fasteners should be replaced with the same or higher property class. If higher property class fasteners are used, these should only be tightened to the strength of the original.

Make sure fastener threads are clean and that you properly start thread engagement. This will prevent them from failing when tightening.

Tighten plastic insert or crimped steel-type lock nuts to approximately 50 percent of the dry torque shown in the chart, applied to the nut, not to the bolt head. Tighten toothed or serrated-type lock nuts to the full torque value.

TORQ2 -UN-07SEP99

Unified Inch Bolt and Cap Screw Torque Values

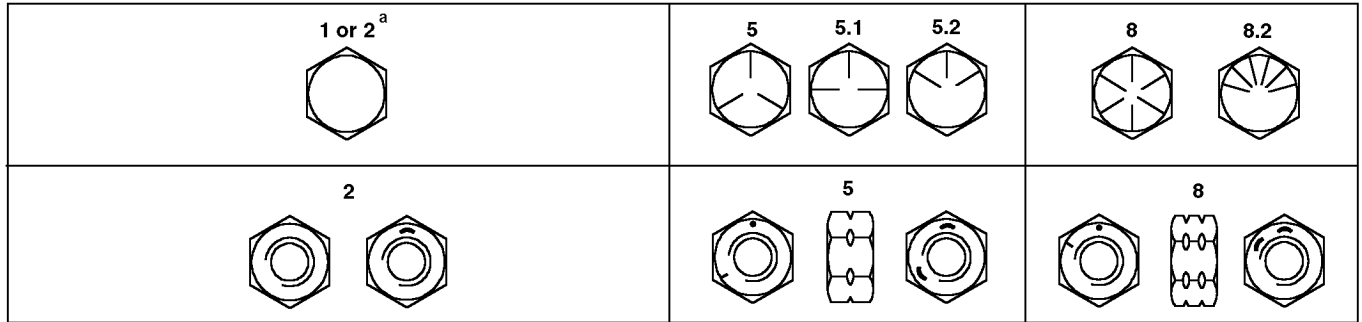

Top, SAE Grade and Head Markings; Bottom, SAE Grade and Nut Markings

Size	Grade 1 (No Mark)		Grade 2 ^a (No Mark)		Grade 5, 5.1 or 5.2		Grade 8 or 8.2	
	Lubricated ^b N•m(lb-ft)	Dry ^c N•m(lb-ft)	Lubricated ^b N•m(lb-ft)	Dry ^c N•m(lb-ft)	Lubricated ^b N•m(lb-ft)	Dry ^c N•m(lb-ft)	Lubricated ^b N•m(lb-ft)	Dry ^c N•m(lb-ft)
1/4	3.8 (2.8)	4.7 (3.5)	6 (4.4)	7.5 (5.5)	9.5 (7)	12 (9)	13.5 (10)	17 (12.5)
5/16	7.7 (5.7)	9.8 (7.2)	12 (9)	15.5 (11.5)	19.5 (14.5)	25 (18.5)	28 (20.5)	35 (26)
3/8	13.5 (10)	17.5 (13)	22 (16)	27.5 (20)	35 (26)	44 (32.5)	49 (36)	63 (46)
7/16	22 (16)	28 (20.5)	35 (26)	44 (32.5)	56 (41)	70 (52)	80 (59)	100 (74)
1/2	34 (25)	42 (31)	53 (39)	67 (49)	85 (63)	110 (80)	120 (88)	155 (115)
9/16	48 (35.5)	60 (45)	76 (56)	95 (70)	125 (92)	155 (115)	175 (130)	220 (165)
5/8	67 (49)	85 (63)	105 (77)	135 (100)	170 (125)	215 (160)	240 (175)	305 (225)
3/4	120 (88)	150 (110)	190 (140)	240 (175)	300 (220)	380 (280)	425 (315)	540 (400)
7/8	190 (140)	240 (175)	190 (140)	240 (175)	490 (360)	615 (455)	690 (510)	870 (640)
1	285 (210)	360 (265)	285 (210)	360 (265)	730 (540)	920 (680)	1030 (760)	1300 (960)
1-1/8	400 (300)	510 (375)	400 (300)	510 (375)	910 (670)	1150 (850)	1450 (1075)	1850 (1350)
1-1/4	570 (420)	725 (535)	570 (420)	725 (535)	1280 (945)	1630 (1200)	2050 (1500)	2600 (1920)
1-3/8	750 (550)	950 (700)	750 (550)	950 (700)	1700 (1250)	2140 (1580)	2700 (2000)	3400 (2500)
1-1/2	990 (730)	1250 (930)	990 (730)	1250 (930)	2250 (1650)	2850 (2100)	3600 (2650)	4550 (3350)

^a Grade 2 applies for hex cap screws (not hex bolts) up to 6 in. (152 mm) long. Grade 1 applies for hex cap screws over 6 in. (152 mm) long, and for all other types of bolts and screws of any length.

^b "Lubricated" means coated with a lubricant such as engine oil, or fasteners with phosphate and oil coatings.

^c "Dry" means plain or zinc plated without any lubrication.

DO NOT use these values if a different torque value or tightening procedure is given for a specific application. Torque values listed are for general use only. Check tightness of fasteners periodically.

Make sure fastener threads are clean and that you properly start thread engagement. This will prevent them from failing when tightening.

Shear bolts are designed to fail under predetermined loads. Always replace shear bolts with identical grade.

Tighten plastic insert or crimped steel-type lock nuts to approximately 50 percent of the dry torque shown in the chart, applied to the nut, not to the bolt head. Tighten toothed or serrated-type lock nuts to the full torque value.

Fasteners should be replaced with the same or higher grade. If higher grade fasteners are used, these should only be tightened to the strength of the original.

Glossary of Terms

ITEM	ABBREVIATION	DESCRIPTION
Accessory	ACC	Secondary electrical system
Air Conditioning	A/C	System used for conditioning air in cab
Air Quality System	AQS	System used to control conditioned air in cab
Alternating Current	AC	Electrical current reversing direction at regularly recurring intervals
Armrest Control Unit	ACU	Armrest control used to control tractor functions
Automatic PowerShift	APS	Automatic shift control system
AutoQuad II Transmission	AQT	Abbreviation
Battery	Bat	A device used to furnish electrical current
Brakes	BR	Abbreviation
Brake Load-Sense	BRL	Reference—Brake load-sense
Central Control Unit	CCU	Computerized system for tractor monitoring
Chrysler Collision Detection	CCD	A communication system linking on-board electronics
Circuit	CCT	A complete path of an electrical current
Circulation Motor		Symbols for circulator motor speeds
	O	Medium speed
	++	Fastest speed
Clean-Oil Reservoir	COR	Reservoir used to contain oil for the hydraulic system
Clockwise	CW	Direction in which the hands of a clock rotate
Cold Cranking Amperes	CCA	Refers to a battery's capability during cold weather operation
Component Technical Manual	CTM	Technical manual developed for the servicing of major components
Counterclockwise	CCW	Direction opposite the rotation of the hands of a clock
Control Flow (Steering Pressure)	CF	Reference—Steering pressure control flow
Control Flow DR	CFD	Reference—Control flow diagnostic receptacle
Controller Area Network	CAN	Data link
Corner Post Display	CPD	Display for system control units
Diagnostic Receptacle	DR	A connection where hydraulic pressure can be measured
Digital Multimeter	DMM	An electrical multifunctional measuring device
Direct Current	DC	Electrical current flowing in one direction only
Displacement Control Valve	DCV	Controls hydraulic pump stroke
Electronic Displacement Control	EDC	Senses and communicates to the Displacement Control Valve demand for hydraulic pump stroke
Electro-Hydraulic	EH	Refers to a hydraulic valve function controlled electrically
Electro-Hydraulic Depth Control	EHDC	Abbreviation—Same as TSDC
Electro-Hydraulic Selective Control Valve	EH SCV	Selective control valve operated with electrical solenoids
Electronic Components Relay	ELX	Refers to the relay powering most of the electronic components
Engine Control Unit	ECU	Computerized system used to govern engine speed

Continued on next page

AG,OURX113,16 -19-03FEB00-1/3

General Information

10
10
9

ITEM	ABBREVIATION	DESCRIPTION
Electrically Programmable Read-Only Memory	EPROM	Abbreviation
Evacuation Diagnostic Receptacle	EVAC	Diagnostic receptacle for prelubrication of pump drive gears
Excess Flow (SCV/Hitch Flow)	EF	Reference—SCV/Hitch flow
Excess Flow Load-Sense (SCV/Hitch Flow)	EFL	Reference—SCV/Hitch load-sense
Forward	FWD	Refers to direction of movement
Gallons per Minute	gpm	Amount of fluid over a period of one minute
Ground-Driven Pump	GDP	Pump used to operate steering and brakes during emergency conditions
Heating, Ventilating, Air Conditioning	HVAC	Abbreviation
Hitch Control Unit	HCU	Computerized system to control hitch functions
Hitch Slip Command	HSC	System to compensate for traction changes
Housing	Hsg	Abbreviation
Ignition	IGN	Control for starting and stopping the tractor
Implement Management System	IMS	System to control several functions at one time
Inside Diameter	ID	Abbreviation
Instrument Control Unit	ICU	Computerized system controlling tractor warning functions
International Standards Organization	ISO	Standards organization
Joint Industry Council Organization	JIC	Standards organization
Lateral Hitch Position	LHP	Refers to hitch positioning for row guidance hitch application
Left-Hand	LH or L-H	Abbreviation
Liquid Crystal Display	LCD	A technology used for displaying information
Manifold Air Pressure	MAP	Abbreviation
Mechanical Front-Wheel Drive	MFWD	Abbreviation
Mechanical Shift Transmission	MST	Abbreviation
Negative	Neg (—)	Refers to a part of an electrical circuit
Number	No.	Abbreviation
Open Operator Station	OOS	Tractor without cab
O-Ring Face Seal	ORFS	A type of seal used in making hydraulic connections
Outside Diameter	OD	Abbreviation
Performance Monitor	Perf. Mon. (PrF)	Abbreviation
Positive	Pos (+)	Refers to a part of an electrical circuit
Potentiometer	POT	A device used to vary electrical voltage
Powershift Control Unit	PCU	Computerized system to control transmission shift functions
Power Shift Transmission	PST	Abbreviation
Power Train Electronic Control Unit	PEC	Abbreviation
Power Take-Off	PTO	Abbreviation
PowrQuad Transmission	PQT	Abbreviation

Continued on next page

AG.OURX113,16 -19-03FEB00-2/3

10
10
10

ITEM	ABBREVIATION	DESCRIPTION
Pressure Control Valve	PCV	Valve used to control pressure within a system
Pressure Regulating Valve	PRV	A device used to regulate pressure in a system
Product Identification Number	PIN	Serial number relating to
Pulse-Width-Modulation	PWM	Method of controlling electrical signals
Pump DR	PD	Reference—Pump diagnostic receptacle
Pump Load-Sense	PLD	Reference—Pump load-sense
Reverse	Rev	Refers to direction of movement
Reverser Control Unit	rcu	Abbreviation
Revolutions Per Minute	rpm	Abbreviation
Right-Hand	RH or R-H	Abbreviation
Rockshaft	RS	Abbreviation
Selective Control Option	SCo	Controller for selective control valve 4 and 5
Selective Control Unit	SCU	Controller for selective control valves 1, 2 and 3
Selective Control Valve	SCV	Device used to control remote hydraulic functions
Set-Up Panel	SUP	Operator control panel used to set selective control valve function
Slow Moving Vehicle	SMV	Warning sign on the rear of the tractor
Society of Automotive Engineering	SAE	Engineering Standards Organization
Specifications	SPEC	Abbreviation
Steering System Control Unit	SSU	Computerized system controlling tractor steering
Steering Load-Sense	STL	Reference—Steering load-sense
Switch	SW	Abbreviation
Tachometer	Tach	Abbreviation
Tail Light	TL	Abbreviation
Temperature	Temp	Abbreviation
TouchSet Depth Control	TSDC	Abbreviation—Same as EHDC
Transmission	Trans	Abbreviation
Transient Voltage Protection	TVP	An electrical device used to protect a circuit from voltage surge
Voltage (Volts)	V	Abbreviation
Voltage Detector	V Det	Abbreviation
Warning Lamp	WL	Abbreviation
Without	W/O	Abbreviation
Wide-Open Throttle	WOT	Full throttle