

Product: John Deere 2130 Tractor Parts Manual

Full Download: <https://www.bobmanualstore.com/downloads/john-deere-2130-tractor-parts-manual/>



# **JOHN DEERE**























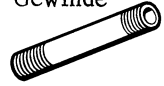

## **Parts Catalog**

### **2130 TRACTOR**

### **PC4128**

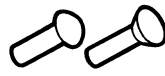
Sample manual. Download All 275 pages at:

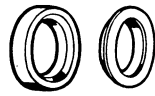
<https://www.bobmanualstore.com/downloads/john-deere-2130-tractor-parts-manual/>

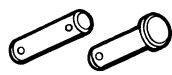
<b>AR</b> Nach Bedarf	<b>I.D.</b> Innendurchmesser	<b>PA</b> Dichtungs- packung 	<b>SET</b> Satz
<b>ASSY</b> Kompletter Zusammenbau	<b>INCL.KEYS</b> Einschliesslich Teile	<b>PAGE</b> Siehe Seite	<b>SH</b> Beilage 
<b>BA</b> Kugel 	<b>KIT</b> Reparatursatz	<b>PACKG</b> Verpackt zu	<b>SP</b> Spezial
<b>BE</b> Kugel-, Rollen-, Nadel- und Drucklager 	<b>L</b> Zahl der Glieder	<b>PE</b> Verschlußdeckel 	<b>SQ</b> Vierkant
<b>BN</b> Kegelrollenlager- Innenring 	<b>LGTH</b> Länge	<b>PG</b> Kerbstift 	<b>SUB.FOR</b> Ersatz für
<b>BP</b> Kegelrollenlager- Außenring 	<b>L.H.</b> Links	<b>PS</b> Spannhülse 	<b>SR</b> Distanzbüchse 
<b>BG</b> Lagerbüchsen 	<b>LOW</b> Unten	<b>PU</b> Verschlußschrauben 	<b>SS</b> Stellschrauben (alle Ausführungen) 
<b>CSK</b> Versenkt	<b>NP</b> Rohrstutzen mit Gewinde 	<b>R</b> Sicherungsringe 	<b>ST</b> Stiftschrauben 
<b>D</b> Paßstift 	<b>NS</b> Sechskantmutter (selbst sichernd) 	<b>R.H.</b> Rechts	<b>TK</b> Stärke
<b>F</b> Schmiernippel und Zubehörteile 	<b>NSEP</b> Einzel nicht lieferbar	<b>RND</b> Rund	<b>UP</b> Oben
<b>FP</b> Rohrverbindungen- und Anschlußteile 	<b>O</b> O-Ring 	<b>REAR</b> Hinten	<b>W</b> Scheibe 
<b>FRONT</b> Vorn	<b>O.D.</b> Aussendurchmesser	<b>RT</b> Nieten 	<b>W/</b> Mit
<b>G</b> Dichtung 	<b>OR</b> Oder	<b>RS</b> Dichtring 	<b>WB</b> Kugelscheiben 
<b>HEX</b> Sechskant	<b>ORD</b> Bestelle	<b>SE</b> Ölabdichtungs- ring 	<b>W/O</b> Ohne
	<b>P</b> Bolzen 		<b>Z</b> Zähnezahl für Ketten- und Zahnrad

## HOW TO USE JOHN DEERE CODED PARTS CATALOGS

In this parts catalog the description of the part has either been deleted (when the identification of the part is obvious) or replaced by a code (when a description is required).

### EACH PARTS CATALOG PAGE IS DIVIDED INTO SIX COLUMNS

Key No.	Part No.	Serial No. or Year	Qty.	Parts Descr. Code	General Information Code
I	II	III * a-d	IV	V	VI
10	T 12345	100001-	2	Be	Sp 3/8" I.D., 2" O.D.

### EXPLANATION OF ABOVE COLUMNS:

- I The Key Number links the illustrated part to the part number in the parts catalog.
- II The Part Number column contains the part number.
- III The Serial Number or Year column identifies significant machine vintage.

Example:

III \* a - d

When the column is blank, the part is used on all machines.

When a number appears after the dash --, the part was used on machines through the vintage number. - 100000

When a number appears before the dash --, the part was introduced with that vintage number and is still being used. 100001 -

When numbers appear before and after the dash --, the part was used beginning with the first vintage number, but was not used after the last vintage number. 100001 - 200000

When X's appear in place of a vintage number, the exact vintage was unknown at the time of publication, but the correct vintage will be given at the next revision of the catalog.

\* The letter in this location indicates that the vintage information is for a particular component:

a - engine serial number

c - transmission serial number

b - chassis serial number

d - implement or attachment serial number

- IV The Quantity column indicates a quantity only when more than one part is used for the parts grouping.
- V The Parts Description Code column is used for parts which may not be easily identified in the exploded view.
- VI Remarks and General Information Codes

Example: By referring to the "Parts Description Codes" table on the next page, codes Sp, 3/8" I.D., 2" O.D. mean: Special, 3/8" Inside Diameter, 2" Outside Diameter.

### HOW TO FIND A NUMBER IF A PART NUMBER IS NOT KNOWN























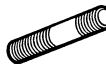

1. Use the sectional index to determine the section in which the part appears.
2. Locate the exploded view and note key numbers of the part.
3. Opposite the key number in parts catalog, determine part number according to serial number, and substitution information.

### HOW TO FIND THE ILLUSTRATION OF A PART IF PART NUMBER IS KNOWN

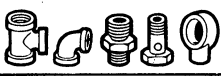
1. Consult numerical index and determine page and key number for the part.
2. Find page and locate part in the exploded view.

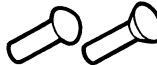
NOTE: On each exploded view, an arrow indicates the forward direction as seen by the Operator.

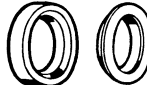
CODE DESIGNATIONS (COLUMNS V AND VI)

<b>AR</b>	As required	<b>I.D.</b>	Inside Diameter	<b>PA</b>	Packing 	<b>SET</b>	Set
<b>ASSY</b>	Complete assembly	<b>INCL.KEYS</b>	Included Keys	<b>PAGE</b>	See page	<b>SH</b>	Shim 
<b>BA</b>	Ball 	<b>KIT</b>	Kit	<b>PACKG</b>	By packet of	<b>SP</b>	Special
<b>BE</b>	Bearings (ball, roller, needle, thrust) 	<b>L</b>	Number of links	<b>PE</b>	Expansion plug 	<b>SQ</b>	Square
<b>BN</b>	Bearing cone 	<b>LGTH</b>	Length	<b>PG</b>	Groove pin 	<b>SUB.FOR</b>	Substitutes for
<b>BP</b>	Bearing cup 	<b>L.H.</b>	Left hand	<b>PS</b>	Spring pin 	<b>SR</b>	Pipe spacer 
<b>BG</b>	Antifriction bearings 	<b>LOW</b>	Lower	<b>PU</b>	Plugs 	<b>SS</b>	Set screw, all heads and ends 
<b>CSK</b>	Countersunk	<b>NP</b>	Pipe nipple 	<b>R</b>	Snap ring 	<b>ST</b>	Studs 
<b>D</b>	Dowel pin 	<b>NS</b>	Self locking hex. nut 	<b>R.H.</b>	Right hand	<b>TK</b>	Thickness
<b>F</b>	Lubrication fitting and accessories 	<b>NSEP</b>	Not supplied separately	<b>RND</b>	Round	<b>UP</b>	Upper
<b>FP</b>	Pipe fittings 	<b>O</b>	"O"-ring 	<b>REAR</b>	Rear	<b>W</b>	Flat washer 
<b>FRONT</b>	Front	<b>O.D.</b>	Outside diameter	<b>RT</b>	Rivets 	<b>W/</b>	With
<b>G</b>	Gasket 	<b>OR</b>	Or	<b>RS</b>	Sealing ring 	<b>WB</b>	Ball washer 
<b>HEX</b>	Hexagonal	<b>ORD</b>	Order	<b>SE</b>	Oil seal 	<b>W/O</b>	Without
		<b>P</b>	Pin 			<b>Z</b>	Gear and sprocket teeth number

## COMMENT UTILISER LES CATALOGUES PIÈCES JOHN DEERE A DESIGNATION CODEE

Dans ces catalogues pièces, la désignation des pièces a été supprimée (lorsque l'identification de la pièce est évidente) ou remplacée par un code (lorsqu'une description est nécessaire).

### CHAQUE PAGE DE CATALOGUE PIÈCES EST DIVISEE EN SIX COLONNES

N <sup>o</sup> de repère	Référence des pièces	N <sup>o</sup> de série ou année	Qté	Code descriptif des pièces	Information générale codée
I	II	III (*) a-d	IV	V	VI
10	T 12345	100001 -	2	Be	Sp 3/8" I.D. 2" O.D.

### SIGNIFICATION DES COLONNES CI-DESSUS:

- I Le numéro de repère est le lien entre l'illustration de la pièce et son numéro de référence dans le catalogue pièces.
- II La référence de la pièce est portée dans la colonne référence des pièces.
- III La colonne numéro de série ou d'année contient des données relatives aux différentes fabrications de la machine.

Exemple:

Quand la colonne est vierge, la pièce se monte sur toutes les machines.

III (\*) a - d

Quand un numéro suit le tiret -, la pièce a été montée jusqu'à la machine portant ce numéro

- 100000

Quand un numéro précède le tiret -, la pièce a été introduite avec ce numéro et est toujours utilisée.

100001 -

Quand des numéros apparaissent avant et après le tiret -, la pièce a été montée depuis le premier numéro, mais pas après le dernier

100001 - 200000

Quand des X apparaissent à la place des numéros, l'indication exacte était inconnue au moment de la réalisation de la publication, mais elle sera donnée lors de la prochaine révision du catalogue.

(\*) La lettre suivant l'astérisque signifie que l'indication concerne un élément particulier:

a - numéro de série du moteur

c - numéro de série de la transmission

b - numéro de série du châssis

d - numéro de série de l'outil au de l'équipement

- IV La colonne quantités ne fait mention de celles-ci que lorsque plus d'une pièce est montée par ensemble.
- V La colonne des codes descriptifs des pièces est utilisée pour des pièces qui peuvent être difficiles à identifier dans la vue éclatée.
- VI Remarque et codes d'information générale -

Exemple: A la page suivante, dans le tableau "Codes descriptifs des pièces", les codes Sp, 3/8" I.D., 2" O.D. signifient: spécial, diamètre intérieur 3/8", diamètre extérieur 2".

### COMMENT TROUVER LA REFERENCE D'UNE PIECE SI L'ON NE CONNAIT PAS CETTE REFERENCE























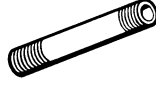

1. Utiliser l'index des sections ou l'index alphabétique pour localiser la vue éclatée où la pièce apparaît.
2. Localiser la pièce dans la vue éclatée et noter son numéro de repère.
3. Se reporter à la nomenclature. En face du numéro de repère de cette nomenclature se trouvent la référence de la pièce correspondant au numéro de série et les informations relatives à la substitution.

### COMMENT TROUVER LE DESSIN D'UNE PIECE SI SA REFERENCE EST CONNUE

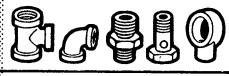
1. Consulter l'index alpha-numérique pour trouver la page et le numéro de repère de la pièce.
2. Chercher la page et situer la pièce dans la vue éclatée.

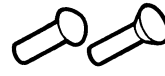
NOTE : Dans chaque vue éclatée, une flèche indique le sens d'avancement de la machine par rapport à l'utilisateur.

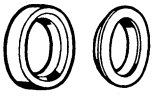
## CODES (COLONNES V e VI)

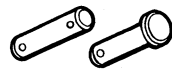
<b>AR</b>	Suivant besoin	<b>I.D.</b>	Diamètre intérieur	<b>PA</b>	Garniture 	<b>SET</b>	Jeu
<b>ASSY</b>	Ensemble complet	<b>INCL.KEYS</b>	Comprend les repères ...	<b>PAGE</b>	Voir page	<b>SH</b>	Cales d'épaisseur 
<b>BA</b>	Bille 	<b>KIT</b>	Nécessaire de réparation	<b>PACKG</b>	Par paquet de	<b>SP</b>	Spécial
<b>BE</b>	Roulements (à billes, à rouleaux, à aiguilles, butées) 	<b>L</b>	Nombre de maillons	<b>PE</b>	Bouchon expansible Pastille de dessablage 	<b>SQ</b>	Carré
<b>BN</b>	Cone de roulement à rouleaux coniques 	<b>LGTH</b>	Longueur	<b>PG</b>	Goupille cannelée 	<b>SUB.FOR</b>	Remplace
<b>BP</b>	Bague extérieure de roulement à rouleaux coniques 	<b>L.H.</b>	Gauche	<b>PS</b>	Goupille élastique 	<b>SR</b>	Entretoise tubulaire 
<b>BG</b>	Bagues antifriction 	<b>LOW</b>	Inférieur	<b>PU</b>	Bouchons 	<b>SS</b>	Vis d'arrêt, toutes têtes et tous bouts 
<b>CSK</b>	Fraisé	<b>NP</b>	Embout tubulaire 	<b>R</b>	Jonc d'arrêt, circlip 	<b>ST</b>	Goujons 
<b>D</b>	Pion de centrage 	<b>NS</b>	Ecrou autofreineur 	<b>R.H.</b>	Droit	<b>TK</b>	Epaisseur
<b>F</b>	Graisseurs et accessoires 	<b>NSEP</b>	Non livré séparément	<b>RND</b>	Rond	<b>UP</b>	Supérieur
<b>FP</b>	Raccords tous modèles 	<b>O</b>	Joint torique 	<b>REAR</b>	Arrière	<b>W</b>	Rondelle plate 
<b>FRONT</b>	Avant	<b>O.D.</b>	Diamètre extérieur	<b>RT</b>	Rivets 	<b>W/</b>	Avec
<b>G</b>	Joint plat 	<b>OR</b>	Ou	<b>RS</b>	Bague d'étanchéité 	<b>WB</b>	Rondelle sphérique 
<b>HEX</b>	Hexagonal	<b>ORD</b>	Commander	<b>SE</b>	Joint à lèvres 	<b>W/O</b>	Sans
		<b>P</b>	Axe 			<b>Z</b>	Nombre de dents des pignons

**FORMA DE UTILIZAR LOS CATALOGOS DE PIEZAS DE RECAMBIO JOHN DEERE  
CON DENOMINACIONES EN CLAVE**

En este catálogo de piezas la descripción de las piezas ha sido suprimida (en aquellos casos en que la identificación es innecesaria) o reemplazada por un número de código (cuando esta identificación es precisa).

Posición	Referencia	N <sup>o</sup> de serie	Cantidad	Clave	Observaciones
I	II	III* a-d	IV	V	VI
10	T 12345	100001 -	2	Be	Sp 3/8" I.D., 2" O.D.

**ACLARACION DE LAS COLUMNAS ANTERIORES:**

- I El número de posición relaciona la pieza ilustrada en la lámina con el número de referencia del catálogo.
- II Esta columna indica la referencia por la que se pide la pieza.
- III El número de serie indica la última o la primera máquina hasta o a partir de la cual se introduce una modificación.

Ejemplo:

Cuando la columna está en blanco, la pieza se usa en todas las máquinas.

Cuando el número aparece después del guión --, la pieza fué montada hasta el número indicado.

Cuando el número aparece antes del guión --, la pieza ha sido introducida a partir del número indicado y continúa utilizándose.

Cuando el número aparece antes y después del guión --, la pieza se utilizó a partir del primer número y se suprimió a partir del segundo número.

Cuando aparecen una o varias X en lugar del número, indican que en el momento de la publicación del catálogo se desconoce el número exacto y que aparecerá en la próxima revisión.

III \* a - d

- 100000

100001 -

100001 - 200000

\* La letra en esta columna indica que el número se refiere sólomente a determinada parte de la máquina.

- a - número de serie del motor
- b - número de serie del bastidor

- c - número de serie de la transmisión
- d - número de serie de implemento o equipo especial.

IV La cuarta columna indica la cantidad de piezas utilizadas en el conjunto cuando lleva más de una.

V La clave se emplea en aquellos casos en que la identificación de la pieza resulta dudosa a la vista de la figura.

VI Observaciones e información general.

Ejemplo:

Cuando nos referimos a las "Claves de designación de las piezas" indicadas en la página siguiente, Sp 3/8" I.D., 2" O.D. significa: Especial 3/8" de diámetro interior, 2" de diámetro exterior.

**FORMA DE ENCONTRAR LA REFERENCIA DE UNA PIEZA CUANDO SE DESCONOCE**













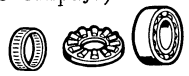







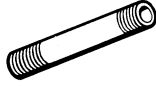
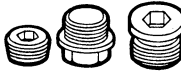
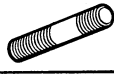

1. Utilizar el índice de secciones para averiguar en que sección aparece la pieza.
2. Localizar, a la vista de la lámina, la pieza deseada y mirar el número de posición que tiene asignado.
3. En la página de la derecha, a continuación del citado número de posición, aparece la referencia de la pieza y la información correspondiente.

**COMO ENCONTRAR EL DIBUJO DE UNA PIEZA CUANDO SE CONOCE EL NUMERO DE REFERENCIA**

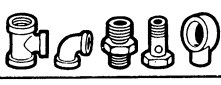
1. Consultar el índice alfanumérico y ver la página y número de posición de la pieza.
2. Hallar la página y localizar la posición de la pieza a la vista de la lámina.

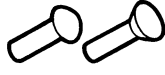
NOTA: En cada lámina una flecha indica la dirección de marcha de la máquina (hacia adelante).

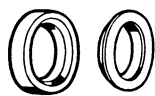
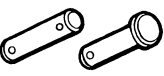
CLAVES (COLUMNAS V y VI)

<b>AR</b> Las que se necesiten	<b>I.D.</b> Diámetro interior	<b>PA</b> Empaquetadura 	<b>SET</b> Juego de piezas
<b>ASSY</b> Conjunto completo	<b>INCL.KEYS</b> Incluidas las llaves	<b>PAGE</b> Véase la página	<b>SH</b> Suplemento 
<b>BA</b> Bola 	<b>KIT</b> Juego de piezas para una reparación	<b>PACKG</b> Por paquete de	<b>SP</b> Especial
<b>BE</b> Rodamiento (de bolas, de rodillos, de agujas, Cojinete de empuje) 	<b>L</b> Número de eslabones	<b>PE</b> Tapón 	<b>SQ</b> Cuadrado
<b>BN</b> Rodamiento cónico (pista interior) 	<b>LGTH</b> Longitud	<b>PG</b> Pasador cilíndrico o cónico con estriado 	<b>SUB.FOR</b> Sustituido por ...
<b>BP</b> Pista exterior del rodamiento 	<b>L.H.</b> Izquierda	<b>PS</b> Pasador elástico 	<b>SR</b> Casquillo distanciador 
<b>BG</b> Cojinetes de antifricción 	<b>LOW</b> Más bajo	<b>PU</b> Tapón roscado 	<b>SS</b> Tornillos de ajuste 
<b>CSK</b> Avellanado	<b>NP</b> Tubo roscado 	<b>R</b> Anillo de seguridad 	<b>ST</b> Espárrago 
<b>D</b> Pasador 	<b>NS</b> Tuerca hexagonal autofrenable 	<b>R.H.</b> Derecha	<b>TK</b> Espesor
<b>F</b> Engrasador 	<b>NSEP</b> No se suministra por separado	<b>RND</b> Redondo	<b>UP</b> Superior
<b>FP</b> Racor 	<b>O</b> Anillo tórico 	<b>REAR</b> Trasero	<b>W</b> Arandela plana 
<b>FRONT</b> Frente	<b>O.D.</b> Diámetro exterior	<b>RT</b> Remache 	<b>W/</b> Con
<b>G</b> Junta 	<b>OR</b> Pídase	<b>RS</b> Arandela 	<b>WB</b> Collarin sellado 
<b>HEX</b> Hexagonal	<b>ORD</b> Pasador 	<b>SE</b> Retén 	<b>W/O</b> Sin
	<b>P</b>		<b>Z</b> Número de dientes de los engranajes

## COME USARE IL CATALOGO JOHN DEERE CON DESCRIZIONE A CODICE

In questo Catalogo Ricambi, la descrizione dei particolari è stata eliminata (dove l'identificazione del particolare è ovvio), oppure sostituita con una sigla in codice (dove è necessaria una descrizione).

### OGNI PAGINA DEL CATALOGO È SUDDIVISA IN SEI COLONNE

Rif.					Descrizione Particolare	
No.	No. part	Anno o No. Serie	Quantità	Codice	Osservazioni	
II	II	III * a-d	IV	V	VI	

### SPIEGAZIONE DEL CONTENUTO DI CIASCUNA COLONNA

- I Il numero di riferimento fa da collegamento fra il particolare illustrato ed il suo numero.  
 II La colonna II contiene i numeri dei particolari  
 III La colonna III identifica la macchina

Esempio:

III \* a - d

Quando non esiste identificazione, significa che il particolare può essere usato su tutte le macchine

Quando è stampato un numero preceduto da un trattino, significa che il particolare è stato montato su tutte le macchine fino a quel numero compreso

- 100000

Quando è stampato un numero seguito da un trattino significa che il particolare è stato montato a partire da quel numero

100001 -

Quando sono stampati due numeri separati da un trattino, significa che il particolare è stato montato su quelle macchine aventi numero intermedio fra i due menzionati

100001 - 200000

Quando al posto del numero appare una X, significa che all'atto della stampa del catalogo non era conosciuto il numero esatto. Il numero esatto apparirà però nelle successive ristampe del catalogo

\* La lettera contrassegnata da asterisco indica per quale componente valga il numero riportato.

a - no. di serie motore

c - no. di serie trasmissione

b - no. di serie telaio

d - no. di serie attrezzatura o equipaggiamento

IV La colonna IV indica la quantità solo quando si usa più di un particolare nel complessivo illustrato

V La colonna V indica con un ben determinato codice di quale parte si tratti, qualora l'identificazione nel disegno possa essere difficoltosa.

VI Osservazioni

Esempio: Facendo riferimento alla tabella "Codice" riportata nella pagina seguente, il codice:

Sp, 3/8" I.D., 2" O.D. significa: Speciale, Diametro interno 3/8", Diametro esterno 2"

### COME INDIVIDUARE IL NUMERO DI UN PARTICOLARE

























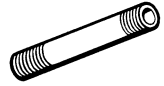

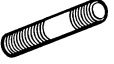

1. Consultare l'indice per individuare la pagina dove appare il particolare
2. Localizzare il particolare sul disegno e annotarne il numero di riferimento
3. Ricavare in base al numero di riferimento il numero del ricambio, in funzione del numero di serie e delle indicazioni di intercambiabilità.

### COME INDIVIDUARE IL PARTICOLARE IN FIGURA QUANDO È NOTO IL NUMERO DEL RICAMBIO

1. Consultare l'indice generale numerico e determinare il numero della figura e quello di riferimento del particolare
2. Trovare la pagina e localizzare il particolare sulla figura

NOTA: Su ciascuna figura, una freccia indica la direzione di marcia vista dalla posizione dell'operatore.

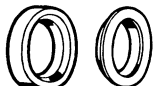
CODICI (COLONNE V e VI)

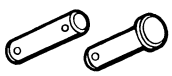
<b>AR</b> Secondo necessità	<b>I.D.</b> Diametro interno	<b>PA</b> Premistoppa 	<b>SET</b> Serie
<b>ASSY</b> Gruppo completo	<b>INCL.KEYS</b> Chiavette incluse	<b>PAGE</b> V. Pagina	<b>SH</b> Spessore 
<b>BA</b> Sfera 	<b>KIT</b> Corredo	<b>PACKG</b> In confezione da	<b>SP</b> Speciale
<b>BE</b> Cuscinetti (rulli, sfere, aghi, reggispinta) 	<b>L</b> Numero di maglie	<b>PE</b> Tappo ad espansione 	<b>SQ</b> Quadro
<b>BN</b> Gabbia cuscinetto conico 	<b>LGTH</b> Lunghezza	<b>PG</b> Spina scanalata 	<b>SUB.FOR</b> Sostituisce il
<b>BP</b> Anello esterno per cuscinetto 	<b>L.H.</b> Sinistra	<b>PS</b> Spina elastica 	<b>SR</b> Tubo distanziale 
<b>BG</b> Boccole Antifrizione 	<b>LOW</b> Inferiore	<b>PU</b> Tappi 	<b>SS</b> Vite di fermo, qualsiasi testa o punta 
<b>CSK</b> Accecato (a incasso) 	<b>NP</b> Raccordo filettato 	<b>R</b> Anello elastico 	<b>ST</b> Prigionieri 
<b>D</b> Grano di riferimento 	<b>NS</b> Dado esagono autobloccante 	<b>R.H.</b> Destra	<b>TK</b> Spessore
<b>F</b> Ingrassatori e parti accessorie 	<b>NSEP</b> Non fornito separatamente	<b>RND</b> Circolare (cilindrico)	<b>UP</b> Superiore
<b>FP</b> Raccordo per tubazioni 	<b>O</b> Guarnizione "Or" 	<b>REAR</b> Posteriore	<b>W</b> Rondella piana 
<b>FRONT</b> Anteriore	<b>O.D.</b> Diametro esterno	<b>RT</b> Rivetti 	<b>W/</b> Con
<b>G</b> Guarnizione 	<b>OR</b> Oppure	<b>RS</b> Anello di tenuta 	<b>WB</b> Rondella sferica 
<b>HEX</b> Esagonale	<b>ORD</b> Ordinare	<b>SE</b> Paraolio 	<b>W/O</b> Senza
	<b>P</b> Spinotto 		<b>Z</b> No. denti corona o pignone

## HET GEBRUIK VAN DE JOHN DEERE ONDERDELEN CATALOGI MET GECODEERDE INDELING

In deze Onderdelen Catalogus is de benaming van de onderdelen weggelaten (wanneer de naam van het onderdeel zelf reeds voldoende duidelijk is) of vervangen door een code (wanneer een omschrijving nodig is).

### ELKE BLADZIJDE IS IN ZES KOLOMMEN ONDERVERDEELD

Basis No.	Onderdeel No.	Serie No. of jaar	Aantal	Omschrijving Code	Algemene code
I	II	III (*) a-d	IV	V	VI
10	T 12345	100001 -	2	Be	Sp 3/8" I.D. 2" O.D.

### VERKLARING VAN BOVENSTAANDE KOLOMMEN:

- I Het Basisnummer bij het afgebeelde onderdeel verwijst naar het onderdeelnummer in de catalogus.
- II In de kolom Onderdeelnummer staat het nummer van het onderdeel.
- III De kolom met Serienummer of jaar geeft aan hoe oud de machine is.

Voorbeeld:

Als er niets in de kolom staat, geldt het onderdeel voor alle machines.

III (\*) a - d

Als achter het streepje - - een nummer staat, werd dat onderdeel voor machines van dat serienummer of jaar gebruikt.

100001 -

Wanneer vóór en achter het streepje - - nummers staan, werd het onderdeel gebruikt te beginnen bij het eerstgenoemde nummer, maar niet na het laatstgenoemde nummer.

10001 - 200000

Als in plaats van het nummer X-jes staan, was het juiste serienummer ten tijde van publicatie niet bekend; het juiste nummer zal dan bij de volgende revisie van de catalogus worden vermeld.

(\*) De hier vermelde letter geeft de aanduiding voor een bepaalde component:

a - motor serienummer

c - transmissie serienummer

b - chassis serienummer

d - werktuig of uitrusting serienummer

- IV De kolom Aantal geeft alleen een aantal aan wanneer voor die onderdelengroep meer dan één onderdeel nodig is.
- V De kolom Omschrijving wordt gebruikt voor onderdelen die in de afbeelding niet gemakkelijk zijn te herkennen.
- VI Omschrijving an Algemene code

Voorbeeld : In de Omschrijving code op de volgende baldzijde betekenen de codes Sp, 3/8" I.D., 2" O.D.:  
Speciaal, 3/8" binnendiameter, 2" buitendiameter.

### HET VINDEN VAN EEN NUMMER ALS HET ONDERDEELNUMMER NIET BEKEND IS























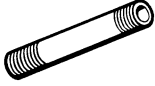

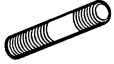

1. Gebruik de Inhoudsopgave van het hoofdstuk waarin het onderdeel voorkomt.
2. Zoek het basisnummer van het betreffende onderdeel in de afbeelding.
3. Tegenover het basisnummer in de catalogus kunt U aan de hand van het serienummer en de overige gegevens het juiste onderdeelnummer vinden.

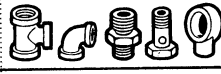
### HET VINDEN VAN DE AFBEELDING VAN EEN ONDERDEEL ALS HET ONDERDEELNUMMER BEKEND IS

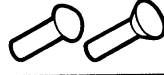
1. Raadpleeg de numerieke index om het bladzijdenummer en het basisnummer van het onderdeel te bepalen.
2. Zoek de betreffende bladzijde op en zoek het onderdeel op in de afgebeelde onderdelengroep.

N.B. - In elke afbeelding van een onderdelengroep wijst een pijl naar de voorzijde, gezien vanaf de bestuurdersplaats.

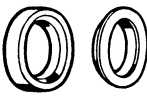
## CODES (KOLOMMEN V en VI)

<b>AR</b> Naar Behoeft	<b>I.D.</b> Binnendiameter	<b>PA</b> Pakkingring, Afdichtring 	<b>SET</b> Stel
<b>ASSY</b> Compleet	<b>INCL.KEYS</b> Inclusief sleutels	<b>PAGE</b> Zie bladzijde	<b>SH</b> Vulplaatje 
<b>BA</b> Kogel 	<b>KIT</b> Pakket	<b>PACKG</b> Een pakket van	<b>SP</b> Speciaal
<b>BE</b> Kogellagers, rollagers, naaldlagers, druk-lagers 	<b>L</b> Aantal schakels	<b>PE</b> Expansieplug 	<b>SQ</b> Vierkant
<b>BN</b> Lagerkooi met binnenring 	<b>LGTH</b> Lengte	<b>PG</b> Gegroefde borgpen 	<b>SUB.FOR</b> Vervangt
<b>BP</b> Lagercup 	<b>L.H.</b> Links	<b>PS</b> (Verende) Holle borgpen 	<b>SR</b> Afstandsbus 
<b>BG</b> Lagerbussen 	<b>LOW</b> Onderste	<b>PU</b> Pluggen 	<b>SS</b> Klemschroef, alle koppen en uiteinden 
<b>CSK</b> Verzonken	<b>NP</b> Zelfborgende zeskante moer 	<b>R</b> Borgveren 	<b>ST</b> Tapeinden 
<b>D</b> Paspas 	<b>NS</b> Wordt niet afzonder- lijk geleverd	<b>R.H.</b> Rechts	<b>TK</b> Dikte
<b>F</b> Smeernippels and toebereiden 	<b>NSEP</b> O-ring 	<b>RND</b> Rond	<b>UP</b> Bovenste
<b>FP</b> Pijpaansluitingen 	<b>O</b> Buitendiameter	<b>REAR</b> Achter	<b>W</b> Platte sluitring 
<b>FRONT</b> Voor	<b>O.D.</b> Of	<b>RT</b> Klinknagels 	<b>W/</b> Met
<b>G</b> Pakking 	<b>OR</b> Bestellen	<b>RS</b> Pakkingring, Afdichtring 	<b>WB</b> Kogelzetel 
<b>HEX</b> Zeskant	<b>ORD</b> Pen 	<b>SE</b> Oliekeerring 	<b>W/O</b> Zonder
	<b>P</b>		<b>Z</b> Aantal tanden op tandwiel en kettingwiel

## SA ANVÄNDER NI JOHN DEERE NYA RESERVDLSKATALOGER MED KODBETECKNING.

I dessa nya reservdelskataloger har delarnas benämning antingen utelämnats eller ersatts med en kod. När benämningen utelämnats kan delen klart indentifieras genom en sprängskiss.

Refnr.	Reservdelsnr.	Ar. Ell. Ser. Nr.	Antal	Kod	Anmärken
I	II	III* a-d	IV	V	VI
10	T 12345	10 001-	2	Be	Sp 3/8" I. D. 2" O.D.

### FÖRKLARING TILL OVANSTAENDE KOLUMNER:

- I Länk mellan illustration och reservdelsnummer.
- II Detta nummer används för att beställa reservdelen.
- III Denna kolumn anger om någon ändring utförts från ett visst serienr.

Exempel:

Om kolumnen är blank så användes delen på alla maskiner

Om det finns ett nummer efter strecken ---, så användes delen fr. o. m. detta serienummer.

Om det finns ett nummer före strecken ---, användes delen fr. o. m. detta serienummer

Om det finns ett nummer både före och efter strecken ---, så började man använda delen vid det första nr. och slutade vid det andra nummer.

Om det finns X i denna kolumn så betyder det att något exakt serienummer ej kan anges då delen började användas. Det rätta serienummer. Anges i nästa upplaga.

\* Dessa bokstäver indikerar om serienumret är till en viss del på maskinen.

a - motorserienr.

c - transmissionsserienr.

b - chassisserienr.

d - tillbehörsserienr.

IV Om denna kolumn är blank så atgar det endast en del.

V Om delen är svar att indentifiera på sprängskissen så anges den här.

VI Anmärkningar. Här anges olika dimensioner och dyl.

Exempel: Refererande till tabellen över reservdelsbeskrivningar på nästa sida, kod SP, 3/8" I. D., 2" O. D. betyder: Special, 3/8" invändig diameter, 2" utvändig diameter.

### SA HÄR GÖR NI FÖR ATT FINNA DELENS ORDERNUMMER.























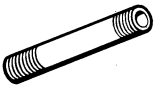

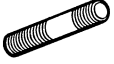
- 1 Genom innehållsförteckningen lokaliserar Ni den sida på vilken delen återfinnes
- 2 Ni finner delen på sprängskissen och notera dess referensnummer.
- 3 Sök upp referensnumret i nummerförteckningen under sprängskissen eller på motstående sida. Därefter kan Ni lätt återfinna rätt reservdelsnummer med hänsyn till maskinens serienummer. Kodbenämningar och den extra information som eventuellt förekommer.

### SA HÄR GÖR NI FÖR ATT FINNA RÄTT ILLUSTRATION OM RESERVDLSNUMRET ÄR KÄNT.

- 1 Sök upp reservdelsnumret i det numeriska registret och notera sidnummer och referensnummer.
- 2 Sök upp sidan och lokalisera delen i sprängskissen

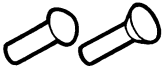
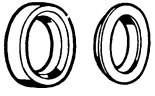
OBS: På varje sprängskiss finns det en pil som visar körriktningen, sedd från förarplatsen.

## KODATS (KOLUMNER V och VI)

<b>AR</b>	I mån av behov	<b>I.D.</b>	Inre diameter	<b>PA</b>	Packning 	<b>SET</b>	Sats, paket
<b>ASSY</b>	Komplett enhet	<b>INCL.KEYS</b>	Inklusive nycklar	<b>PAGE</b>	Se sid.	<b>SH</b>	Shim 
<b>BA</b>	Kula 	<b>KIT</b>	Sats	<b>PACKG</b>	I sats eller paket	<b>SP</b>	Special
<b>BE</b>	Lager (kul, rull, nål, tryck) 	<b>L</b>	Antal länkar eller led	<b>PE</b>	Frostplugg 	<b>SQ</b>	Fyrkantig
<b>BN</b>	Koniskt Rullager 	<b>LGTH</b>	Längd	<b>PG</b>	Låspinne 	<b>SUB.FOR</b>	Ersätter
<b>BP</b>	Lager bana för koniskt Rullager 	<b>L.H.</b>	Vänster sida	<b>PS</b>	Rörsprint 	<b>SR</b>	Avstånds-hylsa 
<b>BG</b>	Glidlager 	<b>LOW</b>	Nedre	<b>PU</b>	Pluggar 	<b>SS</b>	Stoppskurv 
<b>CSK</b>	Försänkt	<b>NP</b>	Rörnippel (skarvrör) 	<b>R</b>	Snap ring 	<b>ST</b>	Pinbult 
<b>D</b>	Stoppinne 	<b>NS</b>	Självlåsande mutter 	<b>R.H.</b>	Höger sida	<b>TK</b>	Tjocklek
<b>F</b>	Smörjnippel och tillbehör 	<b>NSEP</b>	Kan ej erhållas separat	<b>RND</b>	Rund	<b>UP</b>	Slät bricka
<b>FP</b>	Röranslutning 	<b>O</b>	O-ring 	<b>REAR</b>	Bak, bakre	<b>W</b>	Med, inklusive 
<b>FRONT</b>	Fram	<b>O.D.</b>	Yttre diameter	<b>RT</b>	Nitar 	<b>W/</b>	Lager bana 
<b>G</b>	Packning 	<b>OR</b>	Eller	<b>RS</b>	Tätningring 	<b>WB</b>	Utan, exklusive
<b>HEX</b>	Sexkantig	<b>ORD</b>	Order, rekvisition	<b>SE</b>	Oljetätning 	<b>W/O</b>	Antel tänder på drev och kuggjul
		<b>P</b>	Pinne eller sprint 			<b>Z</b>	

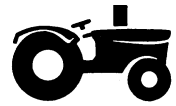



Gruppenübersicht  
Sectional Index  
Index des sections  
Indice de capitulos  
Indice  
Sectionsförteckning  
Groepsinhoud

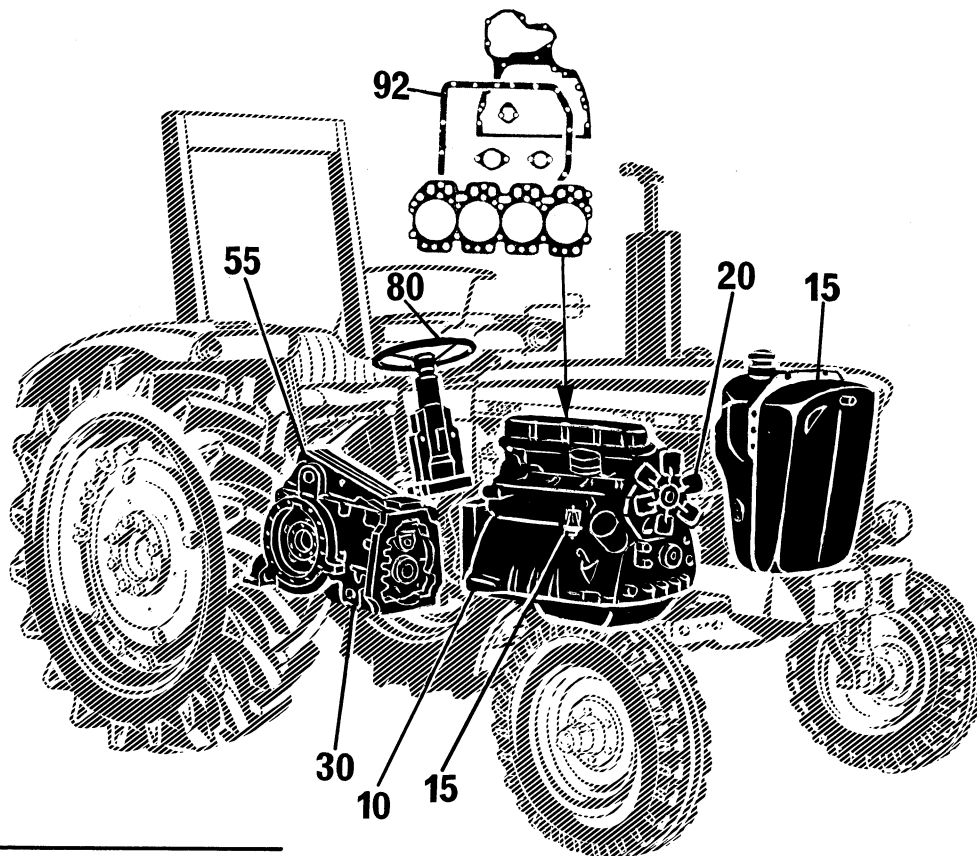
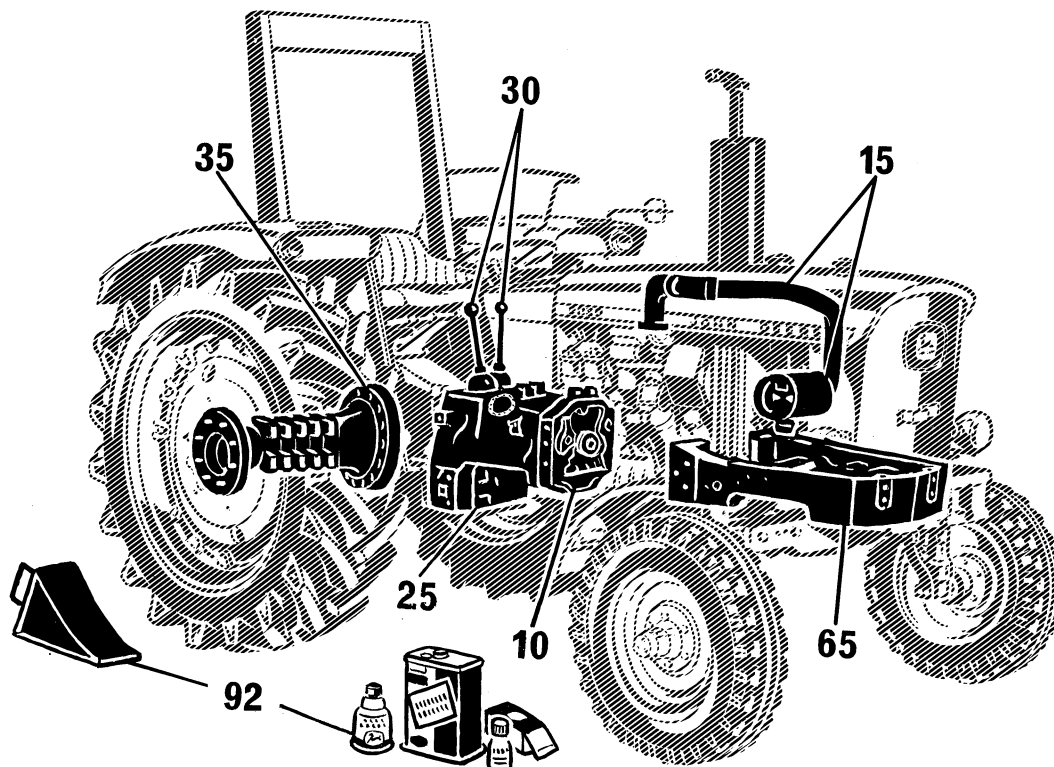



Gruppenübersicht  
 Sectional Index  
 Index des sections  
 Índice de capitulos  
 Indice  
 Sektionsförteckning  
 Groepsinhoud

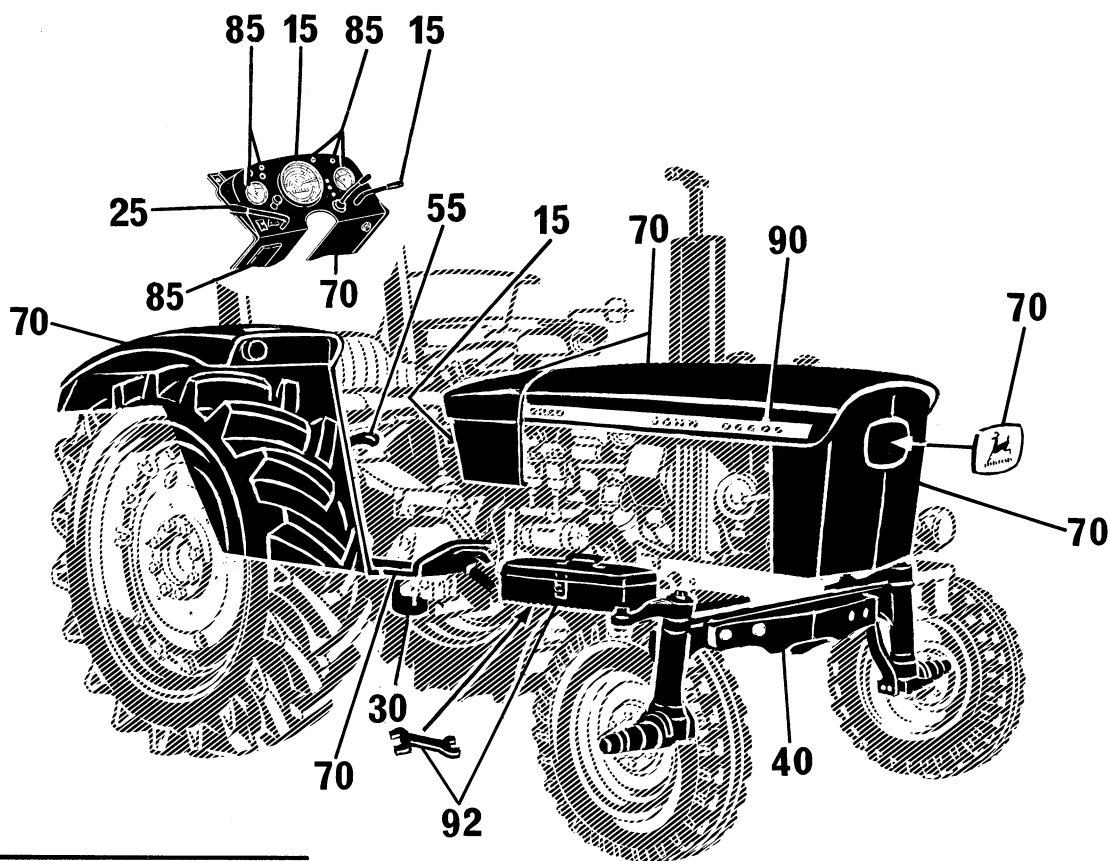
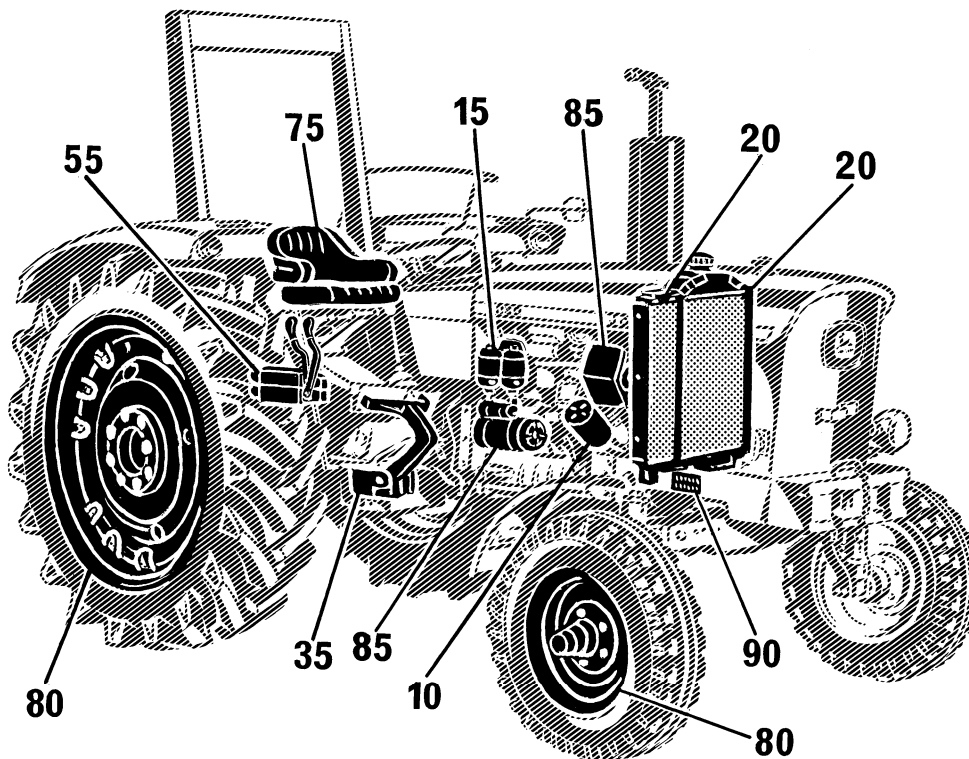

L 56476



Gruppenübersicht  
Sectional Index  
Index des sections  
Indice de capitulos  
Indice  
Sectionsförteckning  
Groepsinhoud

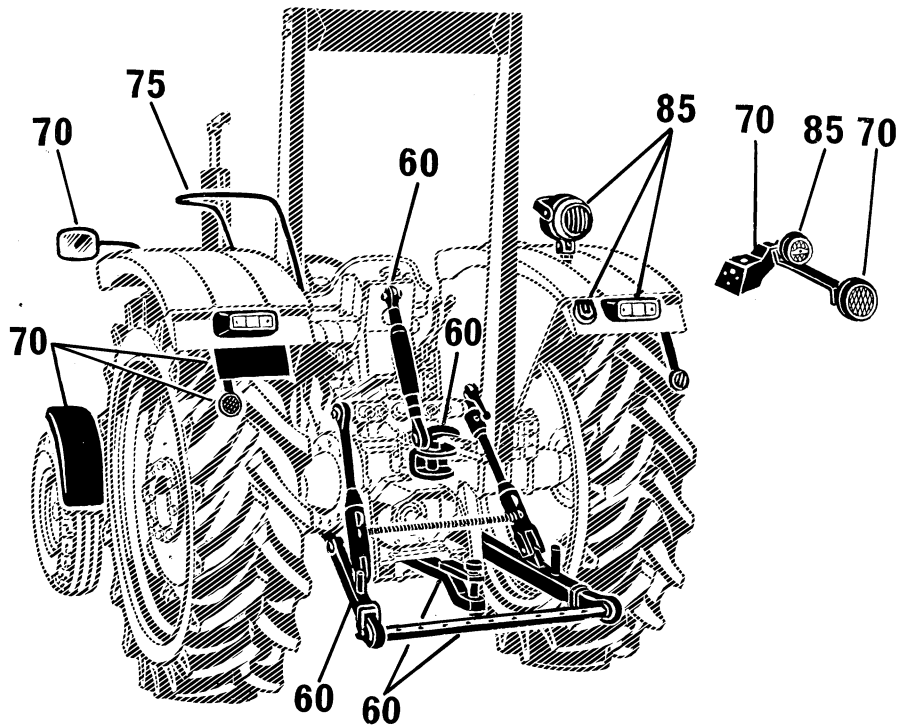
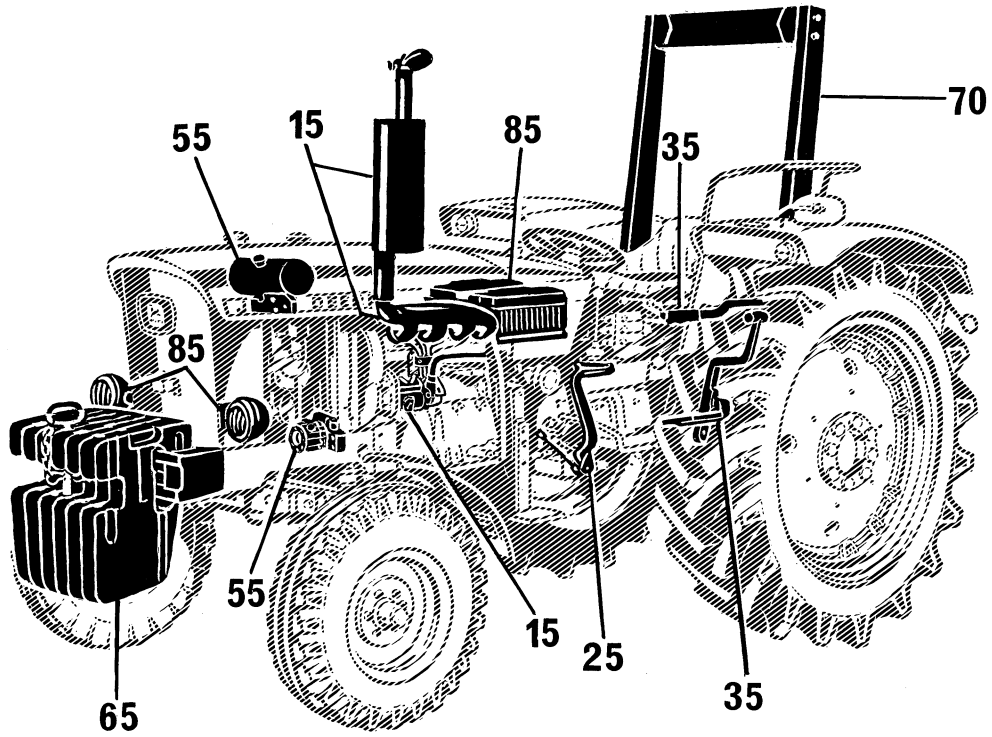

L 56477



Kurzmotor  
 Short Engine  
 Moteur dépouillé pour rechange  
 Motor básico  
 Motore corto  
 Kort motor  
 Ruilmotor

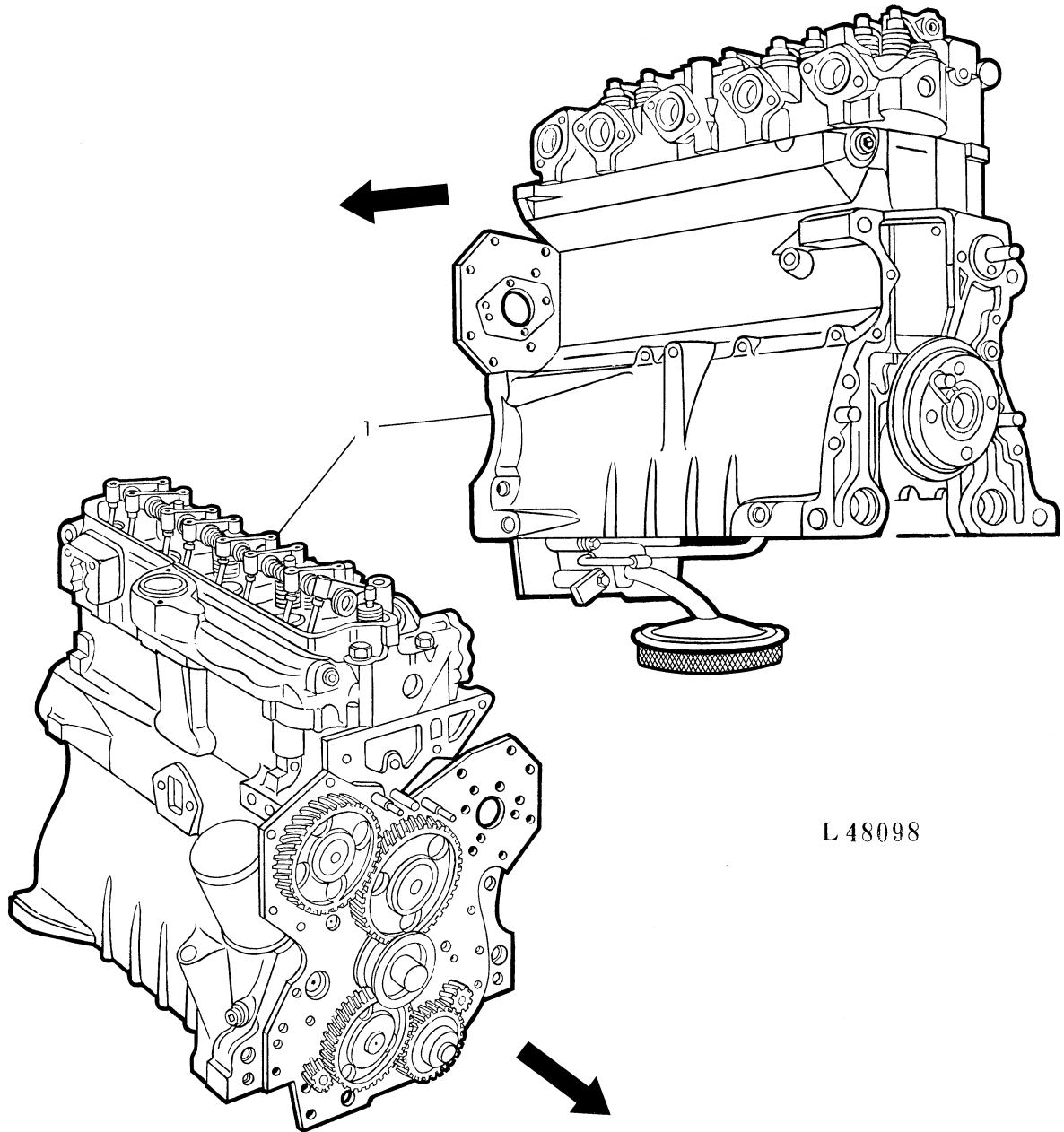

L 48098

I	II	III	IV	V	VI
1	DD 11832			ASSY	



Zylinderblock  
Cylinder Block  
Bloc cylindres  
Bloque de cilindros  
Blocco cilindri  
Cylinderblock  
Cilinderblok

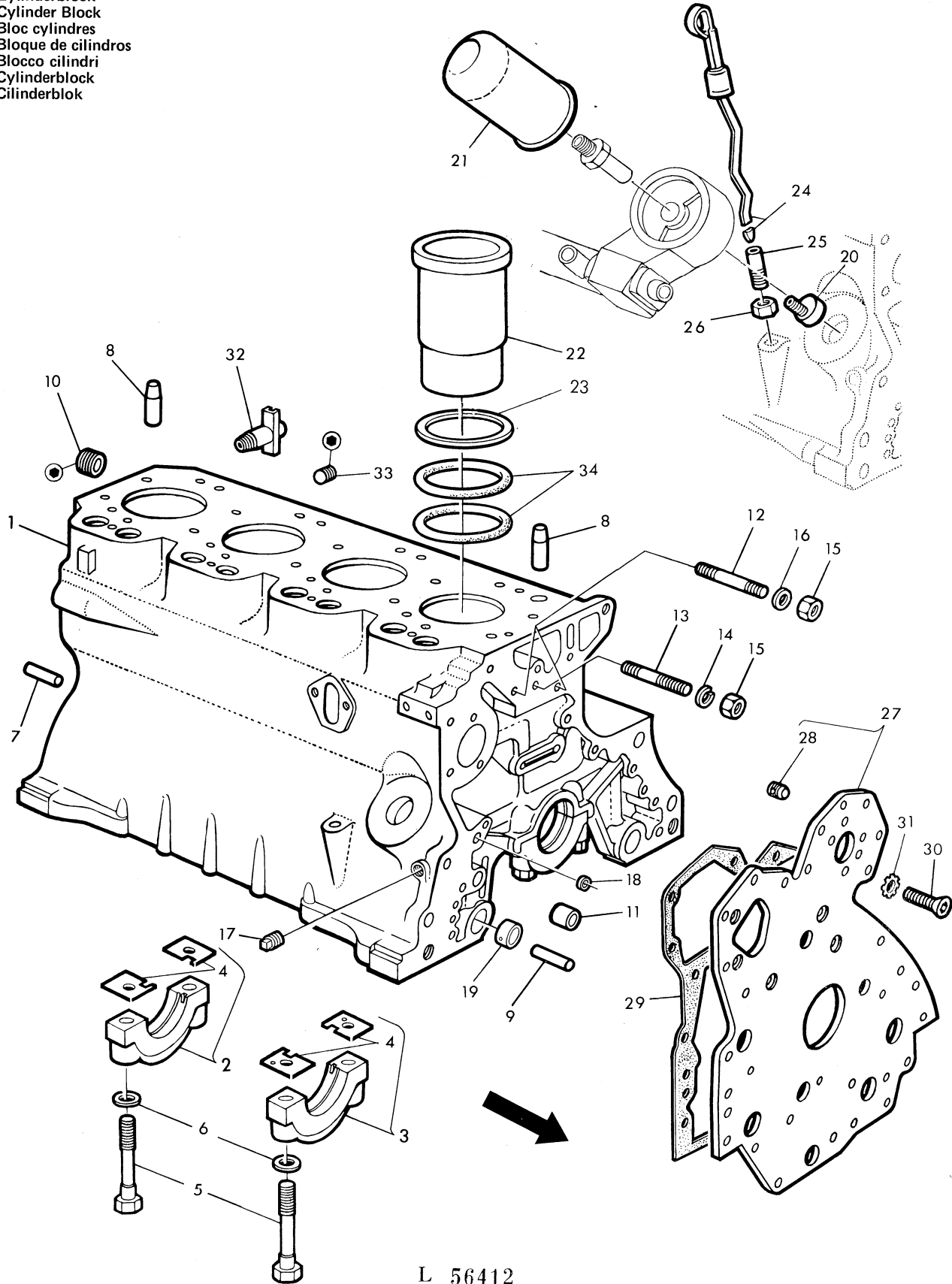

L 56412



I	II	III	IV	V	VI
1	DDX 4941				ASSY, INCL. KEYS 2-13, 17-20, 33
2	AT 21227				REAR, W/SH
3	AT 21226			4	W/SH
4	T 23670			SH	AR 0,076MM (.003")
	T 23671			SH	AR 0,051MM (.002")
5	T 23474			10	SP, 1/2"
6	T 20168			10	W
7	A 120R			2	D
8	R 26241			2	D
9	A 4879R			2	D
10	15H 649				PU 3/4" HEX, CSK
11	R 26493				BG
12	T 33279			2	ST SP
13	T 25701				ST 3/8"
14	12H 304				3/8"
15	14H 812			3	3/8"
16	24H 1303			2	W 13/32"X11/16"X.060"
17	15H 255				PU 3/8" SQ
18	T 18891			2	PE
19	T 20283			6	BG PAGE 10-19
20	T 23435				
21	T 19044				
22	R 51726			4	
23	T 32261			4	PA
24	AT 21534				
25	T 24409				1/2"
26	14H 826				1/2"
27	AT 29928				FRONT, ASSY, W/AT21191, AT22919
28	AT 21191			8	SS SP, 5/16"
	AT 22919			2	SS SP, 3/8"
29	T 24965				G
30	T 20166			5	SS SP, 3/8"X7/8"
31	12H 324			5	SP, 3/8"
32	AT 13740				1/4"
33	15H 275				PU HEX, CSK, 1/4"
34	R 26121			8	D



Zylinderkopf / Zylinderkopfhaube  
Cylinder Head / Rocker Arm Cover  
Culasse / Couvercle de culbuteurs  
Culata / Tapa de balancines  
Testa cilindri / Colperchio punterie  
Cylindertopp / Ventilkåpa  
Cilinderkop / Kleppendeksel

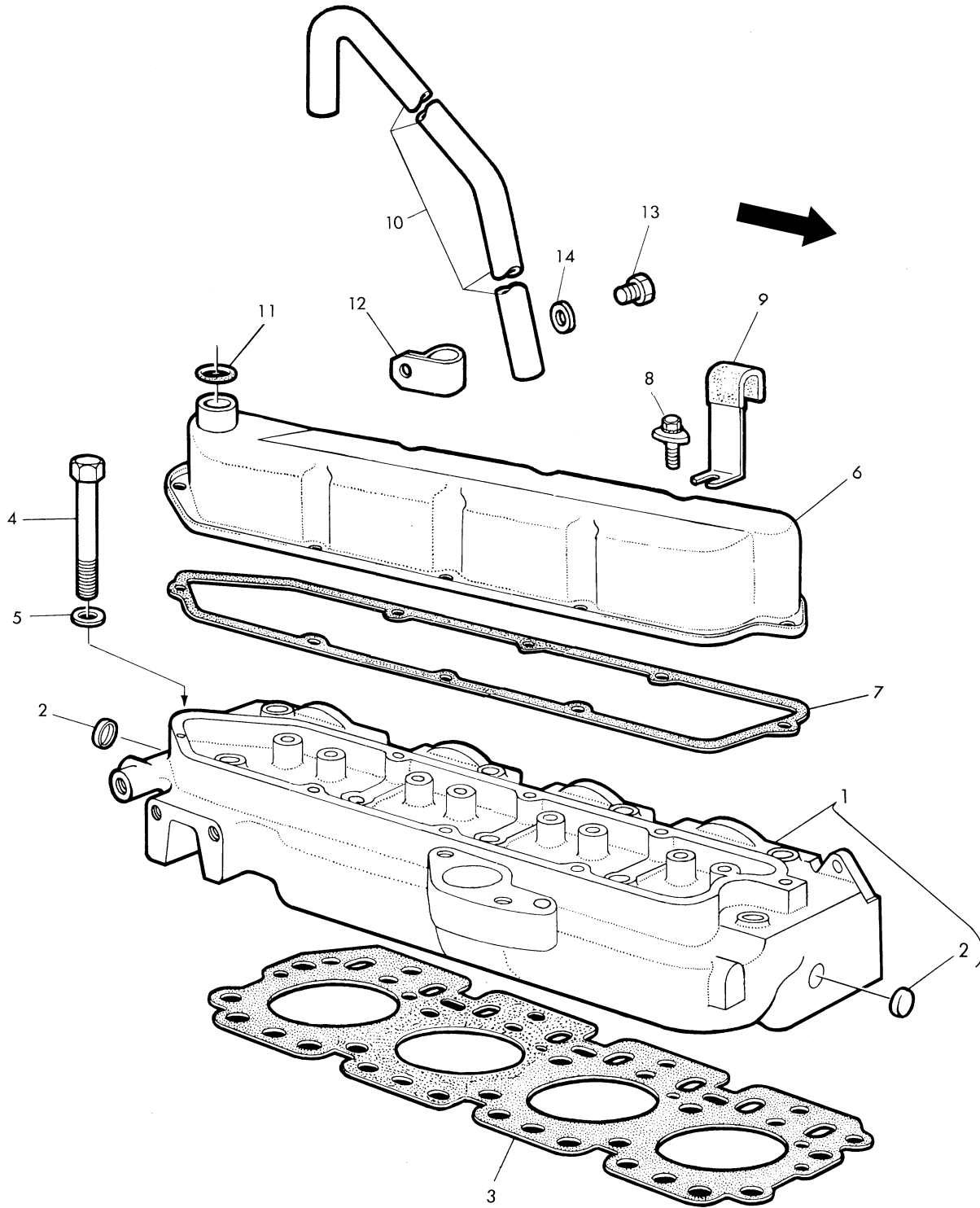

L 51158



I	II	III	IV	V	VI
1	AR 61346				ASSY, W/A3910R
2	A 3910R			2 PE	
3	T 20040			G	
4	R 53223			18	1/2"X4"
5	T 20168			18 W	SP
6	AT 18015				
7	T 20075			G	
8	AR 45530			8	SP
9	T 24151				
10	T 20074				
11	R 495R			O	
12	R 40791				
13	19H 1813				5/16"X5/8"
14	24H 1685			W	11/32"X3/4"X.075"



Nockenwelle / Ventile / Kipphebelachse  
 Camshaft / Valves / Rocker Arm Shaft  
 Arbre à cames / Soupapes / Arbre des culbuteurs  
 Eje de levas / Válvulas / Eje de balancines  
 Albero a camme / Valvole / Albero bilancieri  
 Kamaxel / Ventiler / Vipparmsaxel  
 Nokkenas / Kleppen / Kleptuimelaaras

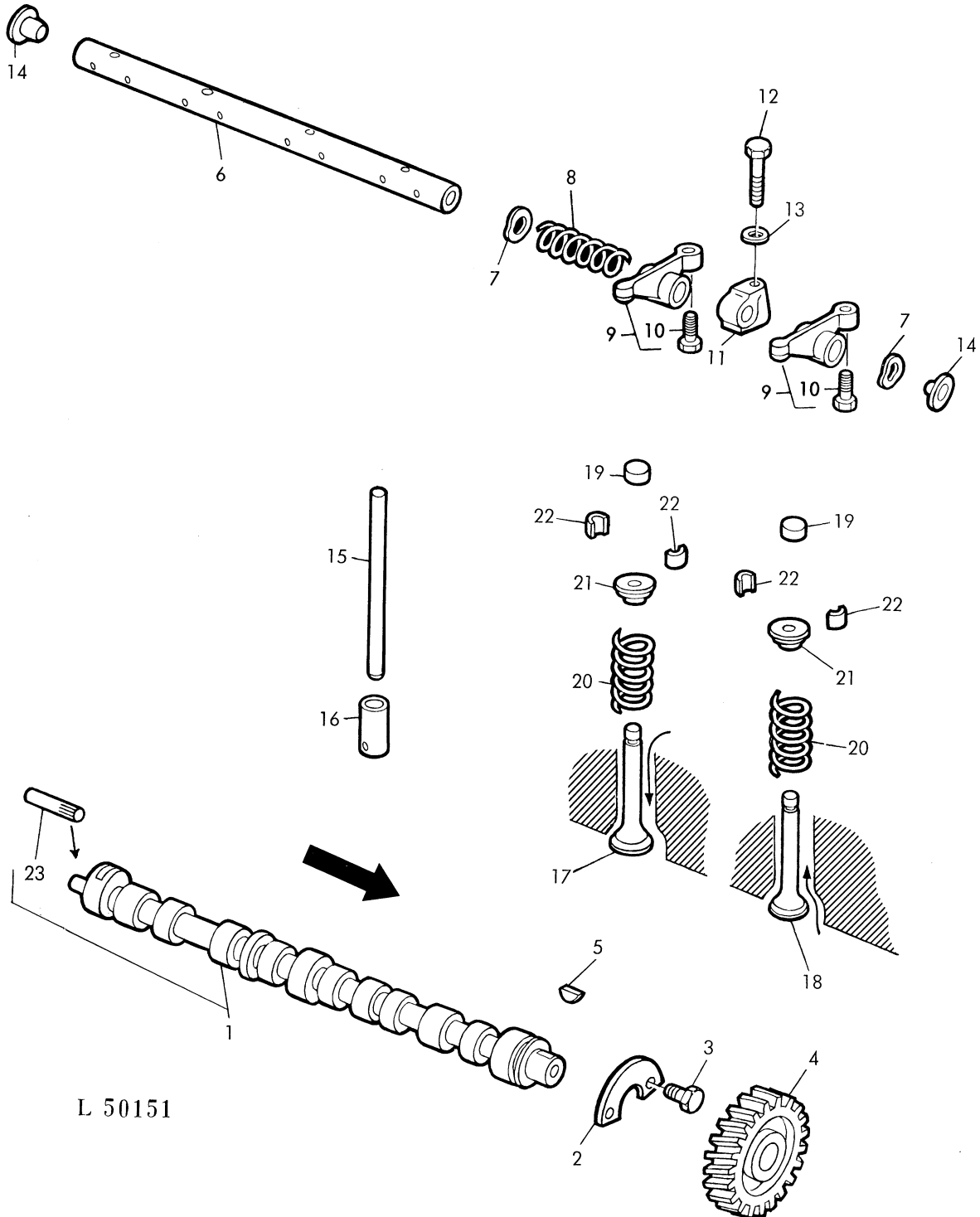

L 50151



I	II	III	IV	V	VI
1	AT 18051				W/T20071
2	T 20072				
3	19H 1731		2		3/8"X1"
4	CDX 6896				Z=48
5	T 28041				SP
6	T 23470				
7	T 20316		2	W	SP
8	T 20314		3		
9	AT 31250		8		INCL.KEYS 10
10	.....		8	SS	NSEP,ORD AT31250
11	T 20315		4		
12	19H 1733		4		3/8"X2-1/2"
13	T 23594		4	W	SP
14	T 23469		2	PE	
15	T 20310		8		
16	T 20073		8		
17	R 52251		4		
18	R 52252		4		
19	T 20129		8		
20	R 26125		8		
21	T 20176		8		
22	T 20077		16		
23	T 20071				



Steuergehäuse/Öleinfüllstutzen  
 Timing Gear Cover/Oil Filler Inlet  
 Couvercle de distribution/Goulotte de remplissage d'huile  
 Tapa de la distribución/Boca de llenado de aceite  
 Coperchio distribuzione/Bocchettone riempimento olio  
 Tídhjulskápa/Oljepáfyllning  
 Distributiedeksel/Olievulpíjp

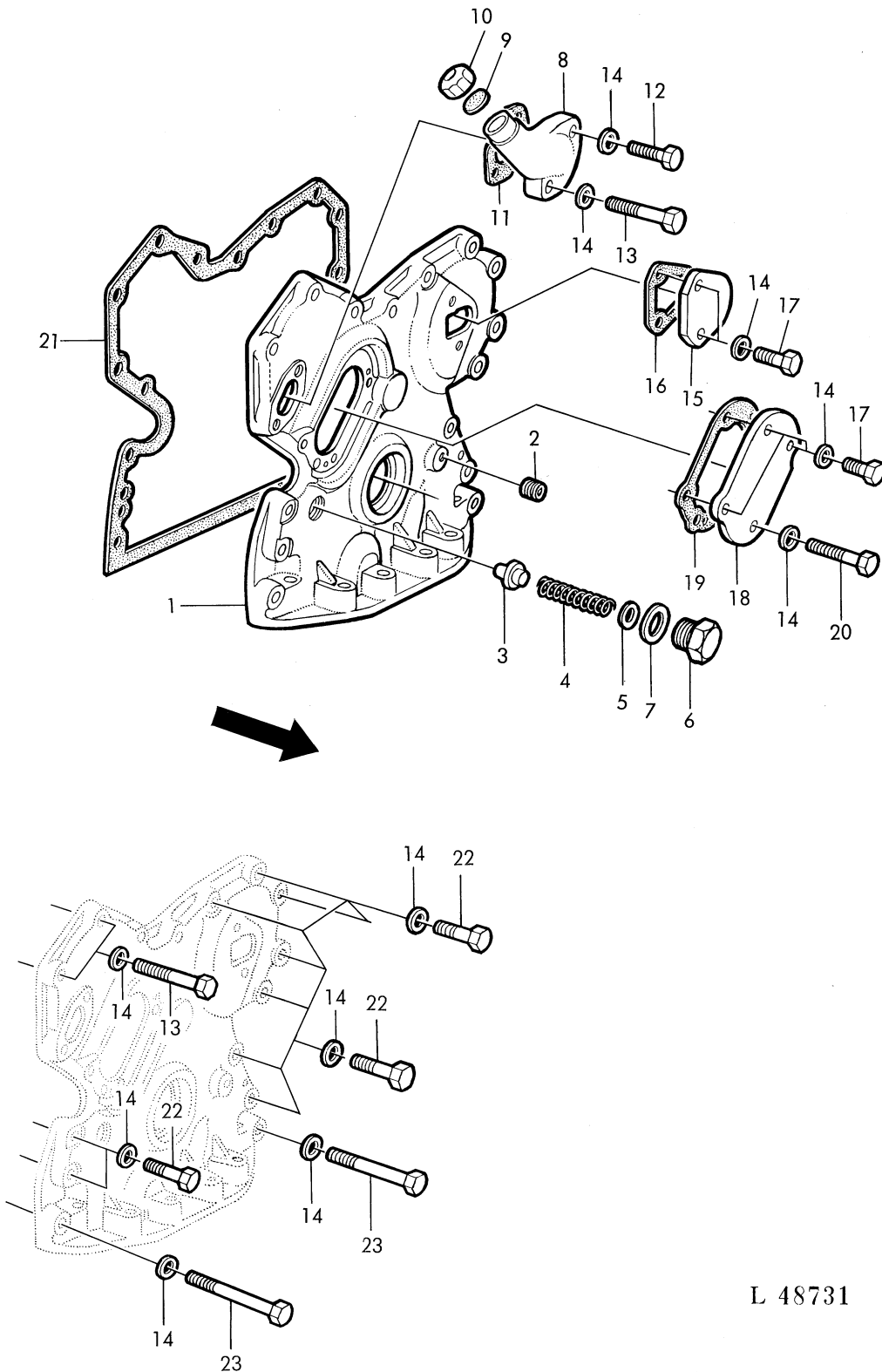

L 48731



I	II	III	IV	V	VI
1	AT 19509				ORD W/KEYS 2,14,17,20
2	15H 275			PU	1/4" HEX,CSK
3	T 20067				
4	T 27658				
5	24H 1290			W	21/64"X3/4"X.036" AR
6	T 27657			PU	
7	A 4827R			RS	
8	T 23614				
9	T 20328			G	
10	T 20294				
11	T 20336			G	
12	19H 2665				3/8"X1-5/8"
13	19H 2128		3		3/8"X3"
14	24H 1304		21	W	13/32"X23/32"X.120"
15	T 20362				
16	T 20364			G	
17	19H 2284		5		3/8"X7/8"
18	T 20272				
19	T 20273			G	
20	19H 1726				3/8"X2-1/4"
21	T 20155			G	
22	19H 1801		9		3/8"X2"
23	19H 1733		2		3/8"X2-1/2"



Kurbelwelle / Steerräder / Hauptlager  
 Crankshaft / Timing Gears / Main Bearings  
 Vilebrequin / Distribution / Paliers Principaux  
 Cigüeñal / Piñones de distribución / Cojinetes de bancada  
 Albero a colli / Ingranaggi della distribuzione / Cuscinetto principale  
 Vevaxel / Tidhjul / Ramlager  
 Krukas / Distributietandwielen / Hoofdlagers

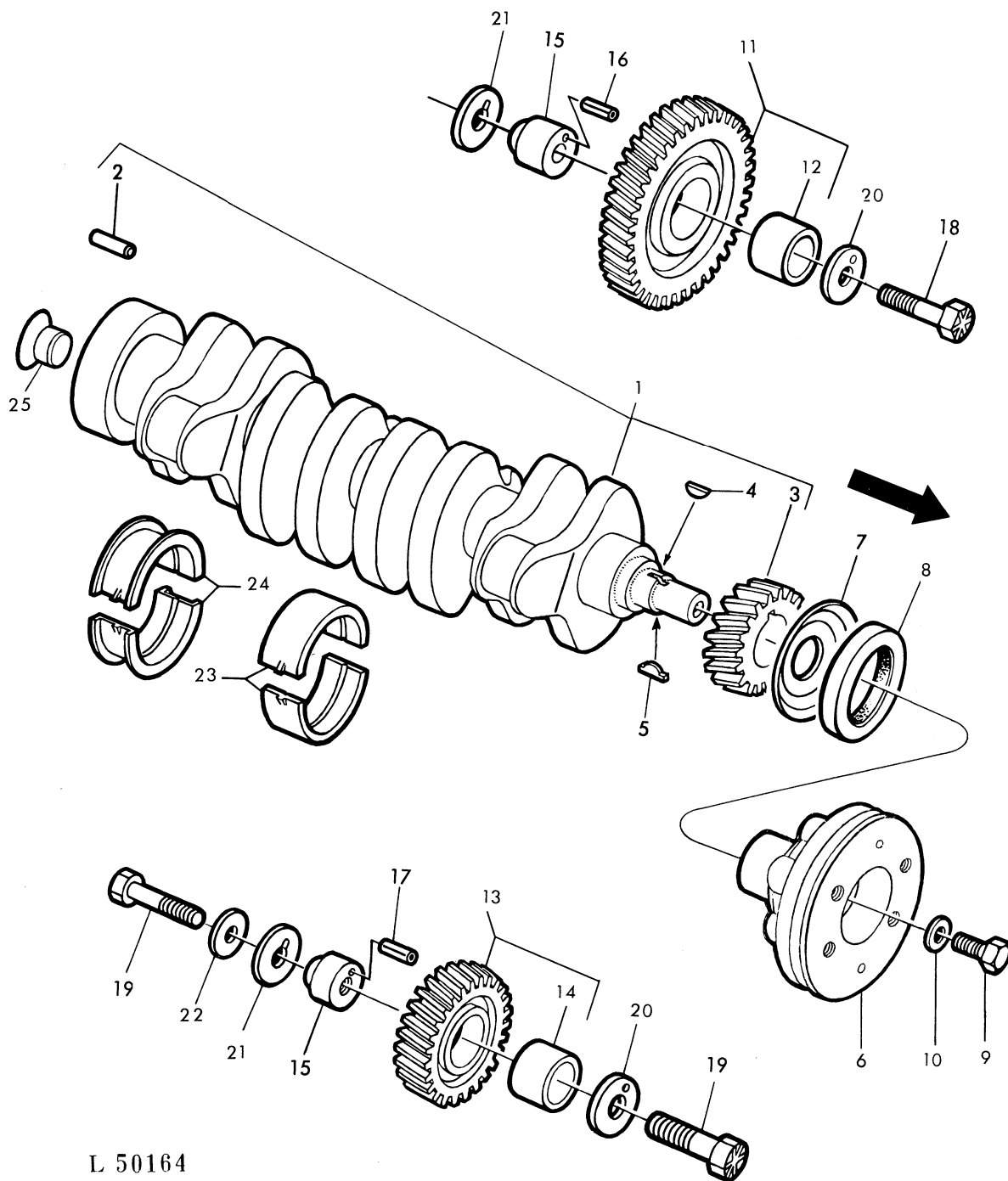

L 50164



I	II	III	IV	V	VI
1	AT 18030				INCL.KEYS 2-4
2	T 26565			D	
3	T 20094				Z=24
4	26H 72				1/8"X5/8"
5	T 23604				SP
6	T 25365				
7	T 20046				
8	AT 21608			SE	FRONT
9	19H 1721				1/2"X1-1/2"
10	T 20217			W	SP
11	AT 18009				UP,Z=55 W/BG
12	T 20034			BG	
13	AT 24252				LOW,Z=45 W/BG
14	T 26321			BG	
15	T 26323		2		
16	34H 283			PS	3/16"X1-1/8"
17	34H 286			PS	3/16"X1-1/2"
18	T 26327			SS	SP
19	T 26325		2	SS	SP
20	T 26326		2	W	SP
21	T 26324		2		SP
22	24H 1890			W	9/32"X1"X.250"
23	AT 21108		4		- 0,051MM (.002")
	AT 21110		4		- 0,254MM (.010")
	AT 21112		4		- 0,508MM (.020")
	AT 21114		4		- 0,762MM (.030")
	AT 21140		4		
24	AT 21130				- 0,051MM (.002")
	AT 21132				- 0,254MM (.010")
	AT 21134				- 0,508MM (.020")
	AT 21136				- 0,762MM (.030")
	AT 21139				REAR
25	T 20445				*1) REAR

\*1) ohne HIGH-LOW Getriebe  
 without HIGH-LOW Shift Unit  
 sans transmission HIGH-LOW  
 sin transmissió HIGH-LOW  
 senza trasmissione HIGH-LOW  
 utan HIGH-LOW  
 zonder HIGH-LOW transmissie



Kolben / Pleuelstange  
Piston / Connecting Rod  
Pistons / Bielles  
Embolo / Biela  
Pistone / Biella  
Kolv / Kolvstake  
Zuigers / Drijfstangen

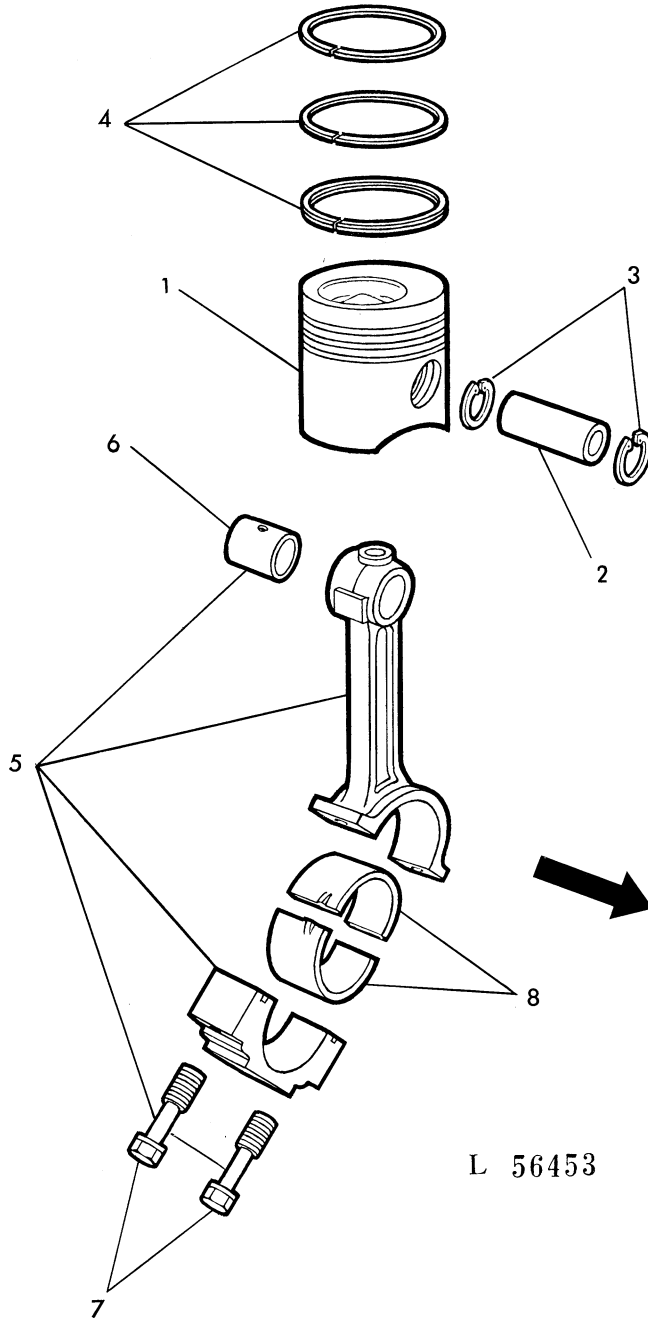

L 56453