

Product: John Deere GS25, GS30, GS45, GS75, HD45, HD75 Commercial Walk-Behind Mowers Service Repair Technical Manual  
Full Download: <https://www.bobmanualstore.com/downloads/john-deere-gs25-gs30-gs45-gs75hd45-hd75-commercial-walk-behind-mowers-service-repair-technical-manual/>

# **GS25, GS30, GS45, GS75 HD45, HD75, Commercial Walk-Behind Mowers**

## **TECHNICAL MANUAL**

**John Deere  
Worldwide Commercial and  
Consumer Equipment Division**

**TM1598 (01Nov97)  
Replaces TM1598 (01Mar97)  
And TM1598 (01Jul96)**

Sample manual. Download All 344 pages at:

<https://www.bobmanualstore.com/downloads/john-deere-gs25-gs30-gs45-gs75hd45-hd75-commercial-walk-behind-mowers-service-repair-technical-manual/>

Litho in U.S.A

Product: John Deere GS25, GS30, GS45, GS75, HD45, HD75 Commercial Walk-Behind Mowers Service Repair Technical Manual  
Full Download: <https://www.bobmanualstore.com/downloads/john-deere-gs25-gs30-gs45-gs75hd45-hd75-commercial-walk-behind-mowers-service-repair-technical-manual/>



**GS75 Gear  
54 in. Commercial  
Walk-Behind Mower**



**GS45 Gear  
48 in. Commercial  
Walk-Behind Mower**



**GS30 Gear  
36 in. Commercial  
Walk-Behind Mower**



**GS25 Gear  
36 in. Commercial  
Walk-Behind Mower**



**HD45 Hydrostatic  
36 in. Commercial  
Walk-Behind Mower**



**HD75 Hydrostatic  
54 in. Commercial  
Walk-Behind Mower**

Sample manual. Download All 344 pages at:  
<https://www.bobmanualstore.com/downloads/john-deere-gs25-gs30-gs45-gs75hd45-hd75-commercial-walk-behind-mowers-ser>

This technical manual is written for an experienced technician and contains sections that are specifically for this product. It is a part of a total product support program.

The manual is organized so that all the information on a particular system is kept together. The order of grouping is as follows:

- Table of Contents
- General Diagnostic Information
- Specifications
- Electrical Wiring Harness Legend
- Component Location
- System Schematic
- Electrical Wiring Harness
- Troubleshooting Chart
- Theory of Operation
- Diagnostics
- Tests & Adjustments
- Repair

*Note: Depending on the particular section or system being covered, not all of the above groups may be used.*

Each section will be identified with a symbol rather than a number. The groups and pages within a section will be consecutively numbered.







We appreciate your input on this manual. To help, there are postage paid post cards included at the back. If you find any errors or want to comment on the layout of the manual please fill out one of the cards and mail it back to us.

All information, illustrations, and specifications in this manual are based on the latest information available at the time of publication. The right is reserved to make changes at any time without notice.

COPYRIGHT® 1997  
Deere & Co.  
John Deere Worldwide Commercial and  
Consumer Equipment Division  
Horicon, WI

All rights reserved

Previous Editions  
COPYRIGHT® 1996, 1997

<b>Safety</b>	
<b>Specifications and Information</b>	
<b>Kawasaki Engines</b>	
<b>Kohler Engine</b>	
<b>Electrical</b>	
<b>Gear Power Train</b>	
<b>Hydrostatic Power Train</b>	

<b>Attachments</b>	
--------------------	---

<b>Miscellaneous</b>	<b>M</b>
----------------------	----------



## **RECOGNIZE SAFETY INFORMATION**

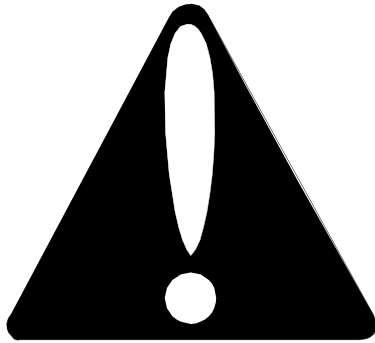

This is the safety-alert symbol. When you see this symbol on your machine or in this manual, be alert to the potential for personal injury.

Follow recommended precautions and safe servicing practices.

### **Understand Signal Words**

A signal word—DANGER, WARNING, or CAUTION—is used with the safety-alert symbol. DANGER identifies the most serious hazards.

DANGER or WARNING safety signs are located near specific hazards. General precautions are listed on CAUTION safety signs. CAUTION also calls attention to safety messages in this manual.

## **REPLACE SAFETY SIGNS**

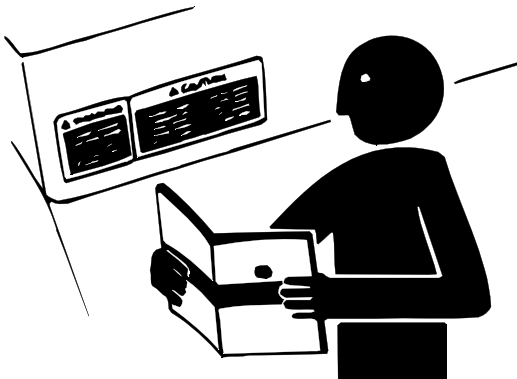

Replace missing or damaged safety signs. See the machine operator's manual for correct safety sign placement.

## **HANDLE FLUIDS SAFELY-AVOID FIRES**

### **Be Prepared For Emergencies**

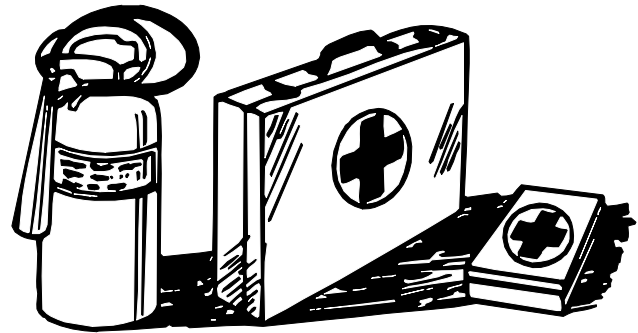

When you work around fuel, do not smoke or work near heaters or other fire hazards.

Store flammable fluids away from fire hazards. Do not incinerate or puncture pressurized containers.

Make sure machine is clean of trash, grease, and debris.

Do not store oily rags; they can ignite and burn spontaneously.

Be prepared if a fire starts.

Keep a first aid kit and fire extinguisher handy.

Keep emergency numbers for doctors, ambulance service, hospital, and fire department near your telephone.

## USE CARE IN HANDLING AND SERVICING BATTERIES

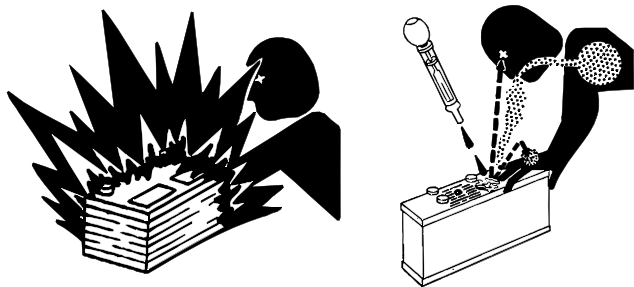

### Prevent Battery Explosions

- Keep sparks, lighted matches, and open flame away from the top of battery. Battery gas can explode.
- Never check battery charge by placing a metal object across the posts. Use a volt-meter or hydrometer.
- Do not charge a frozen battery; it may explode. Warm battery to 16°C (60°F).

### Prevent Acid Burns

- Sulfuric acid in battery electrolyte is poisonous. It is strong enough to burn skin, eat holes in clothing, and cause blindness if splashed into eyes.
- **Avoid acid burns by:**
  1. Filling batteries in a well-ventilated area.
  1. Wearing eye protection and rubber gloves.
  1. Avoiding breathing fumes when electrolyte is added.
  1. Avoiding spilling or dripping electrolyte.
  1. Use proper jump start procedure.
- **If you spill acid on yourself:**
  1. Flush your skin with water.
  1. Apply baking soda or lime to help neutralize the acid.
  1. Flush your eyes with water for 10\_15 minutes.
  1. Get medical attention immediately.
- **If acid is swallowed:**
  1. Drink large amounts of water or milk.
  1. Then drink milk of magnesia, beaten eggs, or vegetable oil.
  1. Get medical attention immediately.

## USE CARE AROUND HIGH-PRESSURE FLUID LINES

### Avoid High-pressure Fluids



Escaping fluid under pressure can penetrate the skin causing serious injury.

Avoid injury from escaping fluid under pressure by stopping the engine and relieving pressure in the system before disconnecting or connecting hydraulic or other lines. Tighten all connections before applying pressure.

Search for leaks with a piece of cardboard. Protect hands and body from high pressure fluids.

If an accident occurs, see a doctor immediately. Any fluid injected into the skin must be surgically removed within a few hours or gangrene may result. Doctors unfamiliar with this type of injury should reference a knowledgeable medical source. Such information is available from Deere & Company Medical Department in Moline, Illinois, U.S.A.

### Avoid Heating Near Pressurized Fluid Lines



Flammable spray can be generated by heating near pressurized fluid lines, resulting in severe burns to yourself and bystanders. Do not heat by welding, soldering, or using a torch near pressurized fluid lines or other flammable materials. Pressurized lines can be accidentally cut when heat goes beyond the immediate flame area.



## USE SAFE SERVICE PROCEDURES

### Wear Protective Clothing

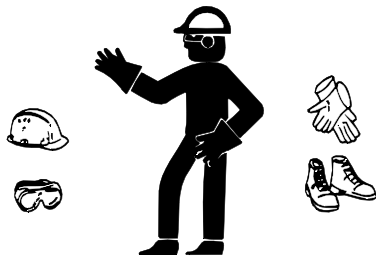

Wear close fitting clothing and safety equipment appropriate to the job.

Prolonged exposure to loud noise can cause impairment or loss of hearing. Wear a suitable hearing protective device such as earmuffs or earplugs to protect against objectionable or uncomfortable loud noises.

Operating equipment safely requires the full attention of the operator. Do not wear radio or music headphones while operating machine.

### Service Machines Safely

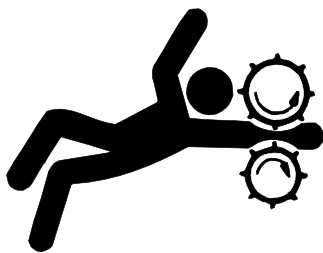

Tie long hair behind your head. Do not wear a necktie, scarf, loose clothing, or necklace when you work near machine tools or moving parts. If these items were to get caught, severe injury could result.

Remove rings and other jewelry to prevent electrical shorts and entanglement in moving parts.

### Use Proper Tools

Use tools appropriate to the work. Makeshift tools and procedures can create safety hazards. Use power tools only to loosen threaded parts and fasteners. For loosening and tightening hardware, use the correct size tools. **DO NOT** use U.S. measurement tools on metric fasteners. Avoid bodily injury caused by slipping wrenches. Use only service parts meeting John Deere specifications.

## Park Machine Safely

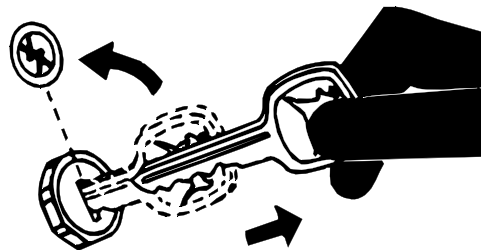

### Before working on the machine:

1. Lower all equipment to the ground.
1. Stop the engine and remove the key.
1. Disconnect the battery ground strap.
1. Hang a "DO NOT OPERATE" tag in operator station.

## Support Machine Properly And Use Proper Lifting Equipment

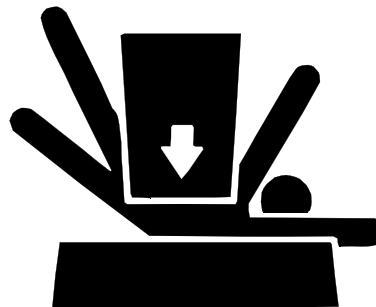

If you must work on a lifted machine or attachment, securely support the machine or attachment.

Do not support the machine on cinder blocks, hollow tiles, or props that may crumble under continuous load. Do not work under a machine that is supported solely by a jack. Follow recommended procedures in this manual.

Lifting heavy components incorrectly can cause severe injury or machine damage. Follow recommended procedure for removal and installation of components in the manual.

## Work In Clean Area

### Before starting a job:

1. Clean work area and machine.
1. Make sure you have all necessary tools to do your job.
1. Have the right parts on hand.
1. Read all instructions thoroughly; do not attempt shortcuts.

## Using High Pressure Washers

Directing pressurized water at electronic/electrical components or connectors, bearings, hydraulic seals, fuel injection pumps or other sensitive parts and components may cause product malfunctions. Reduce pressure and spray at a 45 to 90 degree angle.

## Illuminate Work Area Safely

Illuminate your work area adequately but safely. Use a portable safety light for working inside or under the machine. Make sure the bulb is enclosed by a wire cage. The hot filament of an accidentally broken bulb can ignite spilled fuel or oil.

## Work In Ventilated Area

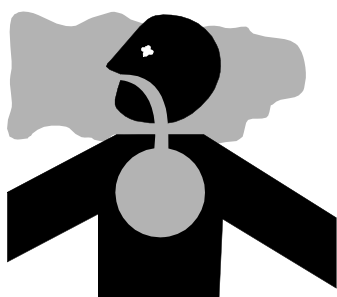

Engine exhaust fumes can cause sickness or death. If it is necessary to run an engine in an enclosed area, remove the exhaust fumes from the area with an exhaust pipe extension.

If you do not have an exhaust pipe extension, open the doors and get outside air into the area.

## WARNING: California Proposition 65 Warning

Diesel engine exhaust and some of its constituents are known to the State of California to cause cancer, birth defects, and other reproductive harm.

Gasoline engine exhaust from this product contains chemicals known to the State of California to cause cancer, birth defects, or other reproductive harm.

## Remove Paint Before Welding Or Heating

Avoid potentially toxic fumes and dust. Hazardous fumes can be generated when paint is heated by welding, soldering, or using a torch. Do all work outside or in a well ventilated area. Dispose of paint and solvent properly. Remove paint before welding or heating: If you sand or grind paint, avoid breathing the dust. Wear an approved respirator. If you use solvent or paint stripper, remove stripper with soap and water before welding. Remove solvent or paint stripper containers and other flammable material from area. Allow fumes to disperse at least 15 minutes before welding or heating.

## Avoid Harmful Asbestos Dust

Avoid breathing dust that may be generated when handling components containing asbestos fibers. Inhaled asbestos fibers may cause lung cancer.

Components in products that may contain asbestos fibers are brake pads, brake band and lining assemblies, clutch plates, and some gaskets. The asbestos used in these components is usually found in a resin or sealed in some way. Normal handling is not hazardous as long as airborne dust containing asbestos is not generated.

Avoid creating dust. Never use compressed air for cleaning. Avoid brushing or grinding material containing asbestos. When servicing, wear an approved respirator. A special vacuum cleaner is recommended to clean asbestos. If not available, apply a mist of oil or water on the material containing asbestos. Keep bystanders away from the area.



## SERVICE TIRES SAFELY



Explosive separation of a tire and rim parts can cause serious injury or death.

Do not attempt to mount a tire unless you have the proper equipment and experience to perform the job. Always maintain the correct tire pressure. Do not inflate the tires above the recommended pressure. Never weld or heat a wheel and tire assembly. The heat can cause an increase in air pressure resulting in a tire explosion. Welding can structurally weaken or deform the wheel.

When inflating tires, use a clip-on chuck and extension hose long enough to allow you to stand to one side and NOT in front of or over the tire assembly. Use a safety cage if available.

Check wheels for low pressure, cuts, bubbles, damaged rims or missing lug bolts and nuts.



## **AVOID INJURY FROM ROTATING BLADES, AUGERS AND PTO SHAFTS**

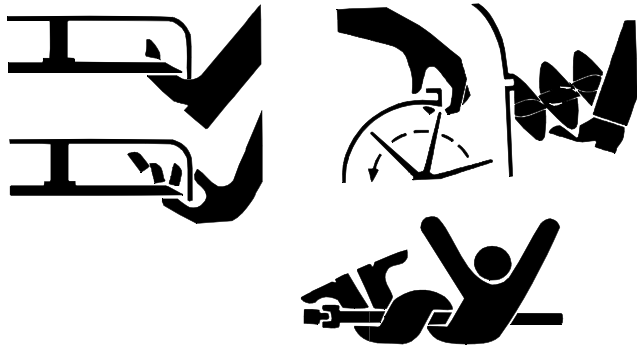

Keep hands and feet away while machine is running. Shut off power to service, lubricate or remove mower blades, augers or PTO shafts.

## **SERVICE COOLING SYSTEM SAFELY**



Explosive release of fluids from pressurized cooling system can cause serious burns.

Shut off machine. Only remove filler cap when cool enough to touch with bare hands. Slowly loosen cap to first stop to relieve pressure before removing completely.

## **HANDLE CHEMICAL PRODUCTS SAFELY**

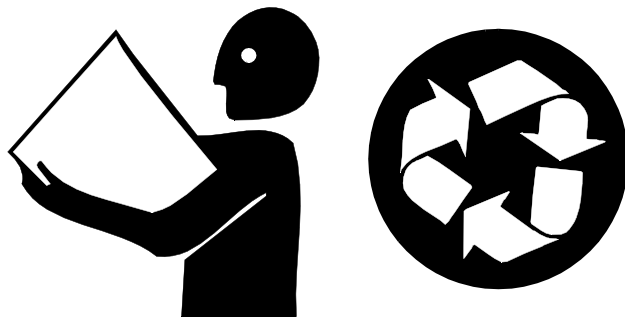

Direct exposure to hazardous chemicals can cause serious injury. Potentially hazardous chemicals used with John Deere equipment include such items as lubricants, coolants, paints, and adhesives.

A Material Safety Data Sheet (MSDS) provides specific details on chemical products: physical and health hazards, safety procedures, and emergency response techniques. Check the MSDS before you start any job using a hazardous chemical. That way you will know exactly what the risks are and how to do the job safely. Then follow procedures and recommended equipment.

## **Dispose of Waste Properly**

Improperly disposing of waste can threaten the environment and ecology. Potentially harmful waste used with John Deere equipment include such items as oil, fuel, coolant, brake fluid, filters, and batteries. Use leakproof containers when draining fluids. Do not use food or beverage containers that may mislead someone into drinking from them. Do not pour waste onto the ground, down a drain, or into any water source. Inquire on the proper way to recycle or dispose of waste from your local environmental or recycling center, or from your John Deere dealer.

## **LIVE WITH SAFETY**



Before returning machine to customer, make sure machine is functioning properly, especially the safety systems. Install all guards and shields.

# CONTENTS

Page



## SPECIFICATIONS & INFORMATION

### SPECIFICATIONS

ENGINE .....	2
POWER TRAIN—GEAR .....	2
POWER TRAIN—HYDROSTATIC .....	3
MOWER DECKS .....	3
GENERAL .....	3
DIMENSIONS .....	3

<b>METRIC FASTENER TORQUE VALUES .....</b>	<b>4</b>
--	----------

<b>INCH FASTENER TORQUE VALUES .....</b>	<b>5</b>
--	----------

### GASOLINE

GASOLINE—NORTH AMERICA .....	6
GASOLINE STORAGE .....	6
GASOLINE—EUROPE .....	7
ENGINE OIL—NORTH AMERICA .....	8
ENGINE OIL—EUROPE .....	8
BREAK-IN ENGINE OIL—NORTH AMERICA .....	9
BREAK-IN ENGINE OIL—EUROPE .....	9
TRANSMISSION GREASE—GEAR .....	10
HYDROSTATIC TRANSAXLE OIL—NORTH AMERICA .....	10
HYDROSTATIC TRANSAXLE OIL—EUROPE .....	11
ANTI-CORROSION GREASE SPECIFICATIONS .....	11
ALTERNATIVE LUBRICANTS .....	12
SYNTHETIC LUBRICANTS .....	12
LUBRICANT STORAGE .....	12
MIXING OF LUBRICANTS .....	12
OIL FILTERS .....	12

### IDENTIFICATION

SERIAL NUMBER INFORMATION .....	13
PRODUCT IDENTIFICATION NUMBER LOCATION .....	13
ENGINE SERIAL NUMBER LOCATION - KAWASAKI ENGINES .....	13
ENGINE SERIAL NUMBER LOCATION - KOHLER ENGINE .....	13
GEAR TRANSMISSION SERIAL NUMBER LOCATION .....	13
HYDROSTATIC TRANSAXLE SERIAL NUMBER LOCATION .....	14
MOWER DECK SERIAL NUMBER LOCATION—36 INCH .....	14
MOWER DECK SERIAL NUMBER LOCATION—48/54 INCH .....	14

## SPECIFICATIONS

## ENGINE



	<b>GS25</b>	<b>GS30</b>	<b>GS45, HD45</b>	<b>GS75, HD75</b>
Horsepower	9.3 Kw (12.5 hp)	9.7 Kw (13 hp)	10.5 Kw (14 hp)	12.7 Kw (17 hp)
Model number	FC401V-BS05	CV13S	FC420V-AS19	FC540V-AS17
Manufacturer	Kawasaki	Kohler	Kawasaki	Kawasaki
Displacement	423 cc (25.8 cu. in.)	398 cc (24.3 cu. in.)	423 cc (25.8 cu. in.)	535 cc (32.6 cu. in.)
No. of cylinders	One	One	One	One
Fast idle speed	3350 ± 100 rpm	3350 ± 100 rpm	3350 ± 100 rpm	3350 ± 100 rpm
Slow idle speed	1450 ± 75 rpm	1550 ± 75 rpm	1450 ± 75 rpm	1450 ± 75 rpm
Ignition	Solid state electronic	Solid state electronic	Solid state electronic	Solid state electronic
Crankcase capacity without oil filter	1.3 L (2.8 U.S. pt.)	1.9 L (4 U.S. pt.)	1.3 L (2.8 U.S. pt.)	1.6 L (3.4 U.S. pt.)
Crankcase capacity with oil filter	1.5 L (3.17 U.S. pt.)		1.6 L (3.4 U.S. pt.)	1.9 L (4.0 U.S. pt.)
Oil filter	Standard	Standard	Standard	Standard
Type of fuel	Regular grade leaded or lead-free	Regular grade leaded or lead-free	Regular grade leaded or lead-free	Regular grade leaded or lead-free
Air cleaner	Dual stage	Dual stage	Dual stage	Dual stage
Governor	Mechanical	Mechanical	Mechanical	Mechanical
Fuel tank capacity	19 L (5.0 U.S. gal.)	19 L (5.0 U.S. gal.)	19 L (5.0 U.S. gal.)	19 L (5.0 U.S. gal.)

## POWER TRAIN—GEAR

	<b>GS25</b>	<b>GS30</b>	<b>GS45</b>	<b>GS75</b>
Transmission	Dana, 5-speed with reverse	Dana, 5-speed with reverse	Dana, 5-speed with reverse	Dana, 5-speed with reverse
Shift mechanism	Enclosed gear with keys	Enclosed gear with keys	Enclosed gear with keys	Enclosed gear with keys
Brakes	Band	Band	Band	Band
Axle	Solid axle, 25 mm (1 in.) diameter, with grease lubricated roller bearings in wheels			
Drive wheels	330 x 165 mm (13 x 6.5 in.)	330 x 165 mm (13 x 6.5 in.)	330 x 165 mm (13 x 6.5 in.)	330 x 165 mm (13 x 6.5 in.)
Ground speeds:				
Forward speeds	5	5	5	5
Reverse Speeds	1	1	1	1
Forward Speed range	2.9 to 9.6 km/h (1.8 to 5.9 mph)	2.9 to 9.6 km/h (1.8 to 5.9 mph)	2.9 to 9.6 km/h (1.8 to 5.9 mph)	2.9 to 9.6 km/h (1.8 to 5.9 mph)
Reverse Speed Range	1.2 km/h (0.75 mph)	1.2 km/h (0.75 mph)	1.2 km/h (0.75 mph)	1.2 km/h (0.75 mph)

**POWER TRAIN—HYDROSTATIC**

	<b>HD45</b>	<b>HD75</b>
Transmission	Eaton 778	Eaton 778
Shift mechanism	Unitized, Infinitely variable, dual hydrostatic transaxles with reverse, and brakes.	
Brakes	Hydrostatic lever for forward, individual turn levers for right, left, and reverse.	
Axle	Internal wet disk	Internal wet disk
Drive wheels	Individual left and right side axles with wheel flanges, roller bearings mounted inside transaxle and splash lubricated.	
Forward Speed range	406 x 165 mm (16 x 6.5 in.)	406 x 165 mm (16 x 6.5 in.)
Reverse Speed Range	0 to 8.1 km/h (0 to 6 mph)	0 to 8.1 km/h (0 to 6 mph)
	0 to 1.6 km/h (0 to 1 mph)	0 to 1.6 km/h (0 to 1 mph)



**MOWER DECKS**

	<b>914 mm (36 in.)</b>	<b>914 mm (36 in.)</b>	<b>1219 mm (48 in.)</b>	<b>1372 mm (54 in.)</b>
Deck material	10-gauge steel, fabricated	10-gauge steel, fabricated	11-gauge steel, one-piece stamped	11-gauge steel, one-piece stamped
Blades	Two, 472 mm (18.6 in.)	Two, 472 mm (18.6 in.)	Three, 422 mm (16.6 in.)	Three, 472 mm (18.6 in.)
Blade drive	V-belt and timed cogged belt	V-belt and timed cogged belt	V-belt with self-adjusting idler	V-belt with self-adjusting idler
Cutting heights	19 to 114 mm (3/4 to 4-1/2in.)	19 to 114 mm (3/4 to 4-1/2in.)	25 to 127 mm (1 to 5 in.)	25 to 127 mm (1 to 5 in.)
Weight (Mower deck only)	83.9 Kg (185 lb)	83.9 Kg (185 lb)	83.5 Kg (184 lb)	87.4 Kg (193 lb)









**GENERAL**

Caster wheels	228 x 89 mm (9 x 3.5 in.)	228 x 89 mm (9 x 3.5 in.)	228 x 89 mm (9 x 3.5 in.)	228 x 89 mm (9 x 3.5 in.)
---------------	---------------------------	---------------------------	---------------------------	---------------------------

**DIMENSIONS**

	<b>GS25</b>	<b>GS30</b>	<b>GS45</b>	<b>GS75</b>
Overall height	1041 mm (41 in.)	1041 mm (41 in.)	1041 mm (41 in.)	1041 mm (41 in.)
Overall length	2032 mm (80 in.)	2032 mm (80 in.)	2032 mm (80 in.)	2032 mm (80 in.)
Overall width	927 mm (36.5 in.)	927 mm (36.5 in.)	1308 mm (51.5 in.)	1460 mm (57.5 in.)
Traction Unit Weight (Without deck)		124.7 Kg (275 lb)	124.7 Kg (275 lb)	136.8 Kg (302 lb)
	<b>HD45</b>	<b>HD75</b>		
Overall height	1118 mm (44 in.)	1118 mm (44 in.)		
Overall length	1981 mm (78 in.)	1981 mm (78 in.)		
Traction Unit Weight (Without deck)	146.1 Kg (322 lb)	162.5 Kg (358 lb)		

METRIC FASTENER TORQUE VALUES

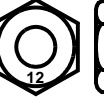
Property Class and Head Markings	4.8	8.8	9.8	10.9	12.9
					
Property Class and Nut Markings	5	10	10	12	
					

TS1163

SIZE	Class 4.8				Class 8.8 or 9.8				Class 10.9				Class 12.9			
	Lubricated <sup>a</sup>		Dry <sup>a</sup>		Lubricated <sup>a</sup>		Dry <sup>a</sup>		Lubricated <sup>a</sup>		Dry <sup>a</sup>		Lubricated <sup>a</sup>		Dry <sup>a</sup>	
	N•m	lb-ft	N•m	lb-ft	N•m	lb-ft	N•m	lb-ft	N•m	lb-ft	N•m	lb-ft	N•m	lb-ft	N•m	lb-ft
M6	48	3.5	6	4.5	9	6.5	11	8.5	13	9.5	17	12	15	11.5	19	14.5
M8	12	8.5	15	11	22	16	28	20	32	24	40	30	37	28	47	35
M10	23	17	29	21	43	32	55	40	63	47	80	60	75	55	95	70
M12	40	29	50	37	75	55	95	70	110	80	140	105	130	95	165	120
M14	63	47	80	60	120	88	150	110	175	130	225	165	205	150	260	109
M16	100	73	125	92	190	140	240	175	275	200	350	225	320	240	400	300
M18	135	100	175	125	260	195	330	250	375	275	475	350	440	325	560	410
M20	190	140	240	180	375	275	475	350	530	400	675	500	625	460	800	580
M22	260	190	330	250	510	375	650	475	725	540	925	675	850	625	1075	800
M24	330	250	425	310	650	475	825	600	925	675	1150	850	1075	800	1350	1000
M27	490	360	625	450	950	700	1200	875	1350	1000	1700	1250	1600	1150	2000	1500
M30	675	490	850	625	1300	950	1650	1200	1850	1350	2300	1700	2150	1600	2700	2000
M33	900	675	1150	850	1750	1300	2200	1650	2500	1850	3150	2350	2900	2150	3700	2750
M36	1150	850	1450	1075	2250	1650	2850	2100	3200	2350	4050	3000	3750	2750	4750	3500

DO NOT use these hand torque values if a different torque value or tightening procedure is given for a specific application. Torque values listed are for general use only and include a ±10% variance factor. Check tightness of fasteners periodically. DO NOT use air powered wrenches.

Shear bolts are designed to fail under predetermined loads. Always replace shear bolts with identical grade.

Fasteners should be replaced with the same grade. Make sure fastener threads are clean and that you properly start thread engagement. This will prevent them from failing when tightening.

When bolt and nut combination fasteners are used, torque values should be applied to the **NUT** instead of the bolt head.









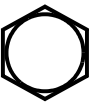

Tighten toothed or serrated-type lock nuts to the full torque value.

<sup>a</sup> "Lubricated" means coated with a lubricant such as engine oil, or fasteners with phosphate and oil coatings. "Dry" means plain or zinc plated (yellow dichromate - Specification JDS117) without any lubrication.

Reference: JDS—G200.

**INCH FASTENER TORQUE VALUES**



SAE Grade and Head Markings	1 or 2 <sup>b</sup> No Marks 	5  5.1  5.2 	8  8.2 
	2 No Marks 	5  	8  

TS1162

SIZE	Grade 1		Grade 2 <sup>b</sup>				Grade 5, 5.1 or 5.2				Grade 8 or 8.2					
	Lubricated <sup>a</sup>		Dry <sup>a</sup>		Lubricated <sup>a</sup>		Dry <sup>a</sup>		Lubricated <sup>a</sup>		Dry <sup>a</sup>		Lubricated <sup>a</sup>		Dry <sup>a</sup>	
	N•m	lb-ft	N•m	lb-ft	N•m	lb-ft	N•m	lb-ft	N•m	lb-ft	N•m	lb-ft	N•m	lb-ft	N•m	lb-ft
1/4	3.7	2.8	4.7	3.5	6	4.5	7.5	5.5	9.5	7	12	9	13.5	10	17	12.5
5/16	7.7	5.5	10	7	12	9	15	11	20	15	25	18	28	21	35	26
3/8	14	10	17	13	22	16	27	20	35	26	44	33	50	36	63	46
7/16	22	16	28	20	35	26	44	32	55	41	70	52	80	58	100	75
1/2	33	25	42	31	53	39	67	50	85	63	110	80	120	90	150	115
9/16	48	36	60	45	75	56	95	70	125	90	155	115	175	130	225	160
5/8	67	50	85	62	105	78	135	100	170	125	215	160	215	160	300	225
3/4	120	87	150	110	190	140	240	175	300	225	375	280	425	310	550	400
7/8	190	140	240	175	190	140	240	175	490	360	625	450	700	500	875	650
1	290	210	360	270	290	210	360	270	725	540	925	675	1050	750	1300	975
1-1/8	470	300	510	375	470	300	510	375	900	675	1150	850	1450	1075	1850	1350
1-1/4	570	425	725	530	570	425	725	530	1300	950	1650	1200	2050	1500	2600	1950
1-3/8	750	550	950	700	750	550	950	700	1700	1250	2150	1550	2700	2000	3400	2550
1-1/2	1000	725	1250	925	990	725	1250	930	2250	1650	2850	2100	3600	2650	4550	3350

DO NOT use these hand torque values if a different torque value or tightening procedure is given for a specific application. Torque values listed are for general use only and include a ±10% variance factor. Check tightness of fasteners periodically. DO NOT use air powered wrenches.

Shear bolts are designed to fail under predetermined loads. Always replace shear bolts with identical grade.

Fasteners should be replaced with the same grade. Make sure fastener threads are clean and that you properly start thread engagement. This will prevent them from failing when tightening.

When bolt and nut combination fasteners are used, torque values should be applied to the **NUT** instead of the bolt head.

Tighten toothed or serrated-type lock nuts to the full torque value.

<sup>a</sup> "Lubricated" means coated with a lubricant such as engine oil, or fasteners with phosphate and oil coatings. "Dry" means plain or zinc plated (yellow dichromate - Specification JDS117) without any lubrication.

<sup>b</sup> "Grade 2" applies for hex cap screws (not hex bolts) up to 152 mm (6-in.) long. "Grade 1" applies for hex cap screws over 152 mm (6-in.) long, and for all other types of bolts and screws of any length.

## GASOLINE—NORTH AMERICA



## CAUTION

Gasoline is **HIGHLY FLAMMABLE**, handle it with care.

**DO NOT** refuel machine while:

- indoors, always fill gas tank outdoors;
- machine is near an open flame or sparks;
- engine is running, **STOP** engine;
- engine is hot, allow it to cool sufficiently first;
- smoking.

Help prevent fires:

- fill gas tank to bottom of filler neck only;
- be sure fill cap is tight after fueling;
- clean up any gas spills **IMMEDIATELY**;
- keep machine clean and in good repair—free of excess grease, oil, debris, and faulty or damaged parts;
- any storage of machines with gas left in tank should be in an area that is well ventilated to prevent possible igniting of fumes by an open flame or spark, this includes any appliance with a pilot light.

To prevent fire or explosion caused by **STATIC ELECTRIC DISCHARGE** during fueling:

- **ONLY** use a clean, approved **POLYETHYLENE PLASTIC** fuel container and funnel **WITHOUT** any metal screen or filter.

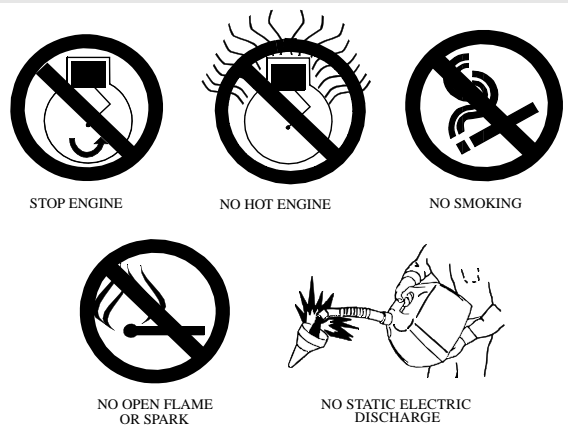

To avoid engine damage:

- DO NOT mix oil with gasoline;
- **ONLY** use clean, fresh unleaded gasoline with an octane rating (anti-knock index) of 87 or higher;
- fill gas tank at the end of each day's operation to help prevent condensation from forming inside a partially filled tank;
- keep up with specified service intervals.

Use of alternative oxygenated, gasohol blended, unleaded gasoline is acceptable as long as:

- the ethyl or grain alcohol blends DO NOT exceed 10% by volume or
- methyl tertiary butyl ether (MTBE) blends DO NOT exceed 15% by volume.

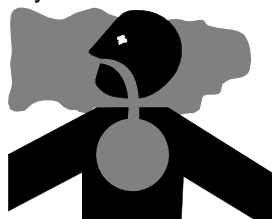

**IMPORTANT: DO NOT** use **METHANOL** gasolines because **METHANOL** is harmful to the environment and to your health.



## WARNING

**California Proposition 65 Warning:** Gasoline engine exhaust from this product contains chemicals known to the State of California to cause cancer, birth defects, or other reproductive harm.

## GASOLINE STORAGE

**IMPORTANT: Keep all dirt, scale, water or other foreign material out of gasoline.**

Keep gasoline stored in a safe, protected area. Storage of gasoline in a clean, properly marked ("**UNLEADED GASOLINE**") **POLYETHYLENE PLASTIC** container **WITHOUT** any metal screen or filter is recommended. **DO NOT** use de-icers to attempt to remove water from gasoline or depend on fuel filters to remove water from gasoline. Use a water separator installed in the storage tank outlet. **BE SURE** to properly discard unstable or contaminated gasoline. When storing unit or gasoline, equivalent to the gasoline. **BE SURE** to follow directions on container and to properly discard empty container.

## GASOLINE—EUROPE

**CAUTION**

Gasoline is **HIGHLY FLAMMABLE**, handle it with care.

**DO NOT** refuel machine while:

- indoors, always fill gas tank outdoors;
- machine is near an open flame or sparks;
- engine is running, **STOP** engine;
- engine is hot, allow it to cool sufficiently first;
- smoking.

**Help prevent fires:**

- fill gas tank to bottom of filler neck only;
- be sure fill cap is tight after fueling;
- clean up any gas spills **IMMEDIATELY**;
- keep machine clean and in good repair—free of excess grease, oil, debris, and faulty or damaged parts;
- any storage of machines with gas left in tank should be in an area that is well ventilated to prevent possible igniting of fumes by an open flame or spark, this includes any appliance with a pilot light.

**To prevent fire or explosion caused by STATIC ELECTRIC DISCHARGE** during fueling:

- **ONLY** use a clean, approved **POLYETHYLENE PLASTIC** fuel container and funnel **WITHOUT** any metal screen or filter.

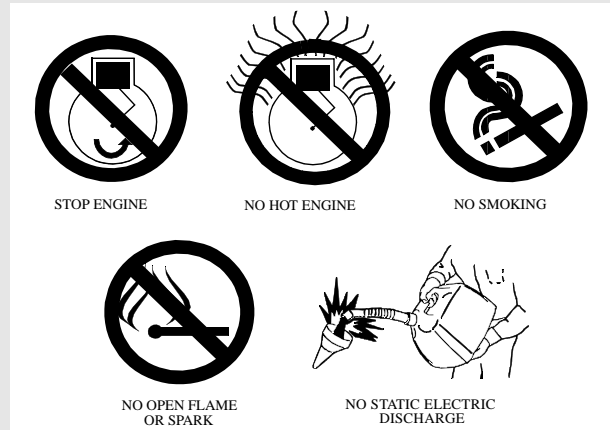

**To avoid engine damage:**

- DO NOT mix oil with gasoline;
- **ONLY** use clean, fresh unleaded gasoline with an octane rating (anti-knock index) of 87 or higher;
- fill gas tank at the end of each day's operation to help prevent condensation from forming inside a partially filled tank;
- keep up with specified service intervals.

Use of alternative oxygenated, gasohol blended, unleaded gasoline is acceptable as long as:

- the ethyl or grain alcohol blends DO NOT exceed 10% by volume or
- methyl tertiary butyl ether (MTBE) blends DO NOT exceed 15% by volume.

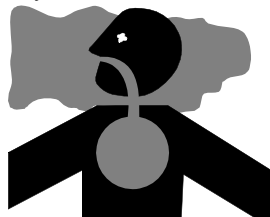

**IMPORTANT: DO NOT** use **METHANOL** gasolines because **METHANOL** is harmful to the environment and to your health.

## ENGINE OIL—NORTH AMERICA

Use the appropriate oil viscosity based on the expected air temperature range during the period between recommended oil changes. Operating outside of these recommended oil air temperature ranges may cause premature engine failure.

The following John Deere oils are **PREFERRED**:

- **PLUS-4®—SAE 10W-40;**
- **TORQ-GARD SUPREME®—SAE 5W-30.**

The following John Deere oils are **also recommended**, based on their specified temperature range:

- **TURF-GARD®—SAE 10W-30;**
- **PLUS-4®—SAE 10W-30;**
- **TORQ-GARD SUPREME®—SAE 30.**

Other oils may be used if above John Deere oils are not available, provided they meet one of the following specifications:

- SAE 10W-40—API Service Classification SG or higher;
- SAE 5W-30—API Service Classification SG or higher;
- SAE 10W-30—API Service Classification SG or higher;
- SAE 30—API Service Classification SC or higher.

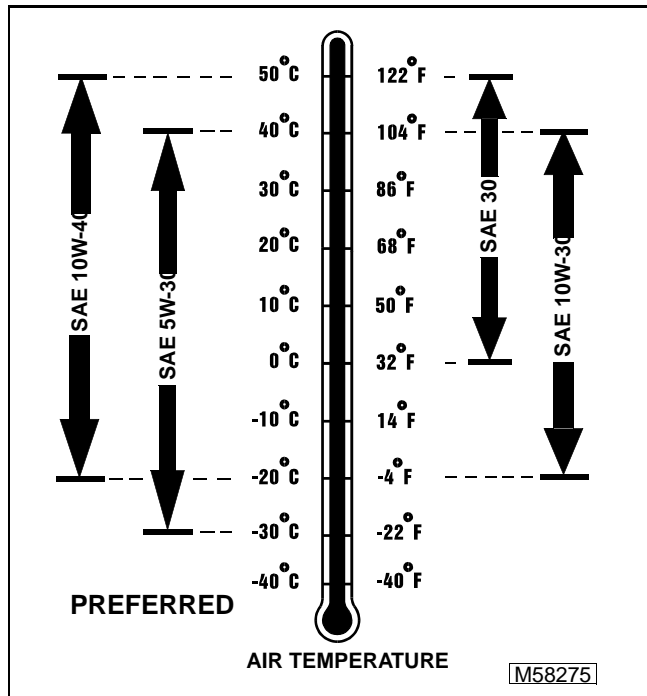

**John Deere Dealers:** You may want to cross-reference the following publications to recommend the proper oil for your customers:

- Module DX, ENOIL2 in JDS-G135;
- Section 530, Lubricants & Hydraulics, of the John Deere Merchandise Sales Guide;
- Lubrication Sales Manual PI7032.

## ENGINE OIL—EUROPE

Use the appropriate oil viscosity based on the expected air temperature range during the period between recommended oil changes. Operating outside of these recommended oil air temperature ranges may cause premature engine failure.

The following John Deere oils are **PREFERRED**:

- **TORQ-GARD SUPREME®—SAE 10W-40;**
- **UNI-GARD™—SAE 10W-40;**
- **TORQ-GARD SUPREME®—SAE 5W-30;**
- **UNI-GARD™—SAE 5W-30.**

The following John Deere oils are **also recommended**, based on their specified temperature range:

- **TORQ-GARD SUPREME®—SAE 10W-30;**
- **UNI-GARD™—SAE 10W-30;**
- **TORQ-GARD SUPREME®—SAE 30;**
- **UNI-GARD™—SAE 30.**

Other oils may be used if above John Deere oils are not available, provided they meet one of the following specifications:

- CCMC Specification G4 or higher.

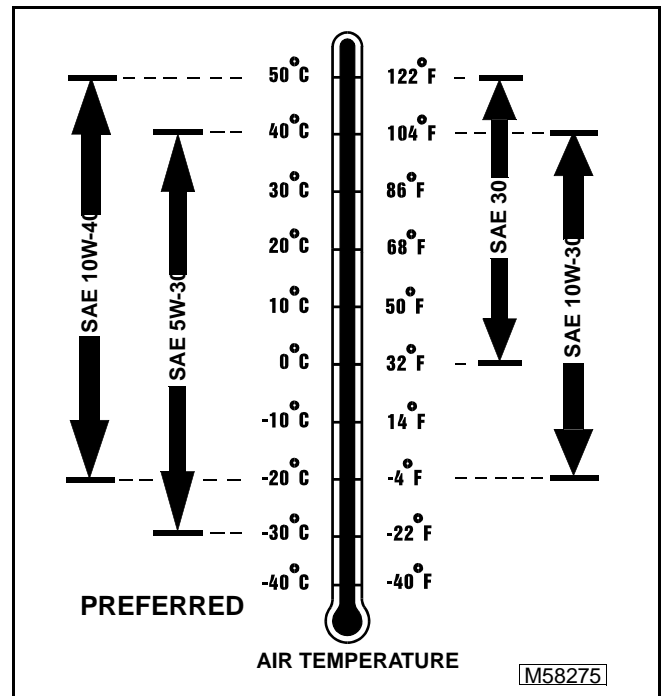

**John Deere Dealers:** You may want to cross-reference the following publications to recommend the proper oil for your customers:

- Module DX, ENOIL2 in JDS-G135;
- Section 530, Lubricants & Hydraulics, of the John Deere Merchandise Sales Guide.

## BREAK-IN ENGINE OIL—NORTH AMERICA

**IMPORTANT:** ONLY use a quality break-in oil in rebuilt or remanufactured engines for the **first 5 hours (maximum) of operation**. DO NOT use oils with heavier viscosity weights than SAE 5W-30 or oils meeting specifications API SG or SH, these oils will not allow rebuilt or remanufactured engines to break-in properly.

The following John Deere oil is **PREFERRED**:

• **BREAK-IN ENGINE OIL.**

John Deere **BREAK-IN ENGINE OIL** is formulated with special additives for aluminum and cast iron type engines to allow the power cylinder components (pistons, rings, and liners as well) to “wear-in” while protecting other engine components, valve train and gears, from abnormal wear. Engine rebuild instructions should be followed closely to determine if special requirements are necessary.

John Deere **BREAK-IN ENGINE OIL** is also recommended for non-John Deere engines, both aluminum and cast iron types.

The following John Deere oil is **also recommended**:

• **TORQ-GARD SUPREME®—SAE 5W-30.**

If the above recommended John Deere oils are not available, use a break-in engine oil meeting the following specification during the first 5 hours (maximum) of operation:

- SAE 5W-30—API Service Classification SE or higher.

**IMPORTANT:** After the break-in period, use the John Deere oil that is recommended for this engine.

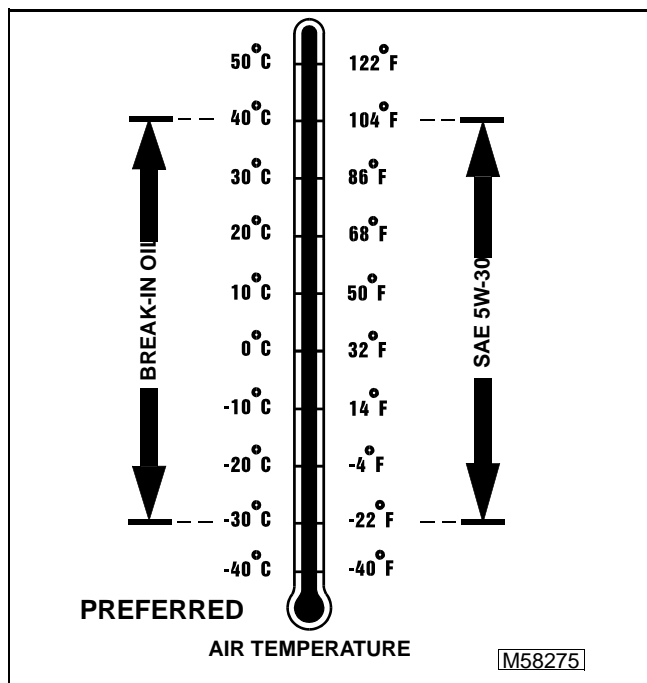

**John Deere Dealers:** You may want to cross-reference the following publications to recommend the proper oil for your customers:

- Module DX, ENOIL4 in JDS-G135;
- Section 530, Lubricants & Hydraulics, of the John Deere Merchandise Sales Guide;
- Lubrication Sales Manual PI7032.



## BREAK-IN ENGINE OIL—EUROPE

**IMPORTANT:** ONLY use a quality break-in oil in rebuilt or remanufactured engines for the **first 5 hours (maximum) of operation**. DO NOT use oils with heavier viscosity weights than SAE 5W-30 or oils meeting CCMC Specification G5—these oils will not allow rebuilt or remanufactured engines to break-in properly.

The following John Deere oil is **PREFERRED**:

• **BREAK-IN ENGINE OIL.**

John Deere **BREAK-IN ENGINE OIL** is formulated with special additives for aluminum and cast iron type engines to allow the power cylinder components (pistons, rings, and liners as well) to “wear-in” while protecting other engine components, valve train and gears, from abnormal wear. Engine rebuild instructions should be followed closely to determine if special requirements are necessary.

John Deere **BREAK-IN ENGINE OIL** is also recommended for non-John Deere engines, both aluminum and cast iron types.

The following John Deere oil is **also recommended**:

• **TORQ-GARD SUPREME®—SAE 5W-30.**

If the above recommended John Deere oils are not available, use a break-in engine oil meeting the following specification during the first 5 hours (maximum) of operation:

- SAE 5W-30—CCMC Specification G4 or higher.

**IMPORTANT:** After the break-in period, use the John Deere oil that is specified for this engine.

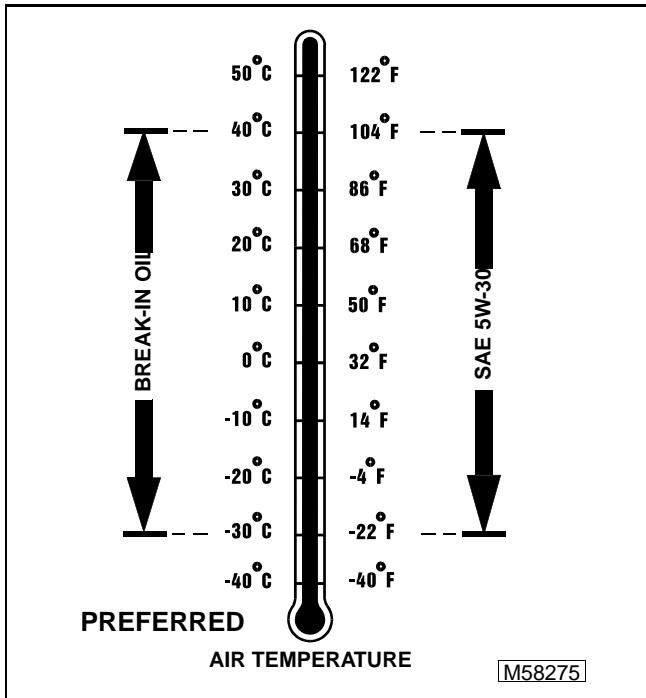

**John Deere Dealers:** You may want to cross-reference the following publications to recommend the proper oil for your customers:

- Module DX, ENOIL4 in JDS-G135;
- Section 530, Lubricants & Hydraulics, of the John Deere Merchandise Sales Guide.

**TRANSMISSION GREASE—GEAR**

Use the following gear grease based on the air temperature range. Operating outside of the recommended grease air temperature range may cause premature gear transmission failure.

**IMPORTANT:** ONLY use these specified greases in this transmission. DO NOT mix any other greases in this transmission. DO NOT use any BIO-GREASE in this transmission.

**ONLY** use the following **PREFERRED** grease as the input shaft needle bearing lubricant:

- **Unirex N3 Grease®—M120263.**

Other greases may be used as the input shaft needle bearing lubricant if they meet or exceed the following specification:

- ASTM D-1743, NLGI Grade 1.

**ONLY** use the following **PREFERRED** grease as the gear housing lubricant:

- **Shell Darina D Grease®—AM119608.**

Other greases may be used as the gear housing lubricant if they meet or exceed the following specification:

- ASTM D-1743, NLGI Grade 1.

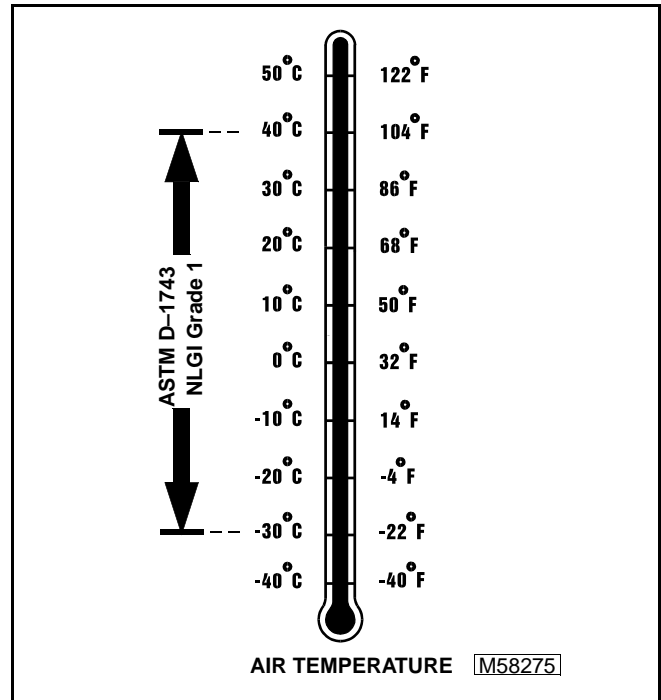

**John Deere Dealers:** You may want to cross-reference the following publications to recommend the proper grease for your customers:

- Module DX, GRE A1 in JDS-G135;
- Section 530, Lubricants & Hydraulics, of the John Deere Merchandise Sales Guide;
- Lubrication Sales Manual PI7032.

**HYDROSTATIC TRANSAXLE OIL—NORTH AMERICA**

**IMPORTANT:** DO NOT use engine oil or “Type F” (Red) Automatic Transmission Fluid in this transmission. DO NOT mix any other oils in this transmission. DO NOT use BIO-HY-GARD® in this transmission.

Use recommended oil viscosity based on the expected air temperature range during the service interval.

The following John Deere transmission and hydraulic oil is **PREFERRED**:

- **HY-GARD® — JDM J20C.**
- **TURF-GARD® — SAE 10W-30;**
- **PLUS-4® — SAE 10W-30;**

TORQ-GARD SUPREME® SAE 30. Other oils may be used if above recommended John Deere oil is not available, provided they meet the following specification:

- **John Deere Standard JDM J20C.**

**IMPORTANT:** If minimum air temperature should fall below -25°C (-13°F), the transmission oil must be heated to at least five degrees above the lower limit before start-up or transmission may be damaged. For prolonged operation under heavy load in air temperatures above 50°C (122°F) reduce service interval by 50%.

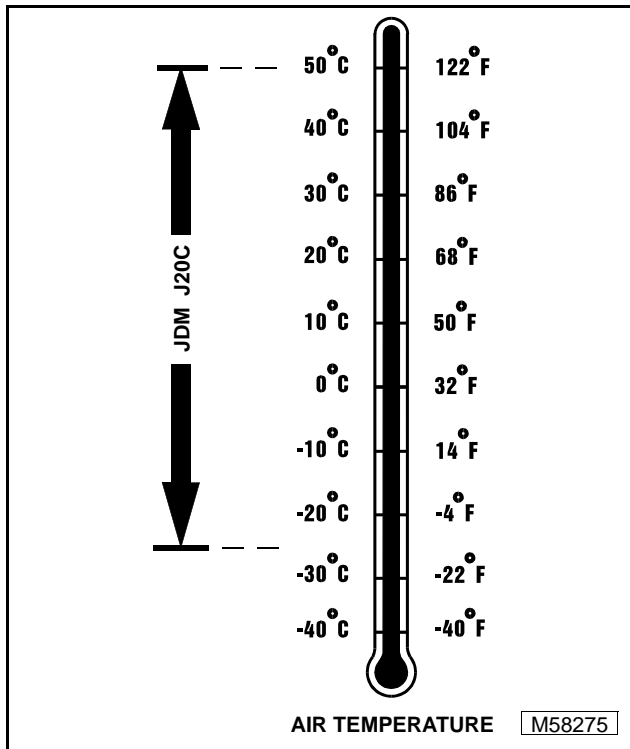

**John Deere Dealers:** You may want to cross-reference the following publications to recommend the proper oil for your customers:

- Module DX,ANTI in JDS-G135;
- Section 530, Lubricants & Hydraulics, of the John Deere Merchandise Sales Guide;
- Lubrication Sales Manual PI7032.

*NOTE: Disregard the John Deere All Weather Hydrostatic Fluid (JDM J21A) listing—it has been eliminated from the specification.*

## HYDROSTATIC TRANSAXLE OIL—EUROPE

**IMPORTANT:** DO NOT use engine oil or “Type F” (Red) Automatic Transmission Fluid in this transmission. DO NOT mix any other oils in this transmission. DO NOT use BIO-HY-GARD® in this transmission.

The following John Deere transmission and hydraulic oil is **PREFERRED**:

- HY-GARD®—JDM J20C.

Other oils may be used if above recommended John Deere oil is not available, provided they meet the following specification:

- John Deere Standard JDM J20C.



**IMPORTANT:** If minimum air temperature should fall below -25°C (-13°F), the transmission oil must be heated to at least five degrees above the lower limit before start-up or transmission may be damaged. For prolonged operation under heavy load in air temperatures above 50°C (122°F) reduce service interval by 50%.

**John Deere Dealers:** You may want to cross-reference the following publications to recommend the proper oil for your customers:

- Module DX,ANTI in JDS-G135;
- Section 530, Lubricants & Hydraulics, of the John Deere Merchandise Sales Guide.

*NOTE: Disregard the John Deere All Weather Hydrostatic Fluid (JDM J21A) listing—it has been eliminated from the specification.*

## ANTI-CORROSION GREASE SPECIFICATIONS

This anti-corrosion grease is formulated to provide the best protection against absorbing moisture, which is one of the major causes of corrosion. This grease is also superior in its resistance to separation and migration.

The following anti-corrosion grease is **PREFERRED**:

- DuBois MPG-2® Multi-Purpose Polymer Grease—M79292.

Other greases may be used if they meet or exceed the following specifications:

- John Deere Standard JDM J13A2, NLGI Grade 1.

**IMPORTANT:** Use only DuBois MPG-2® for electrical connector corrosion control. DO NOT substitute any other grease for electrical connector corrosion control.

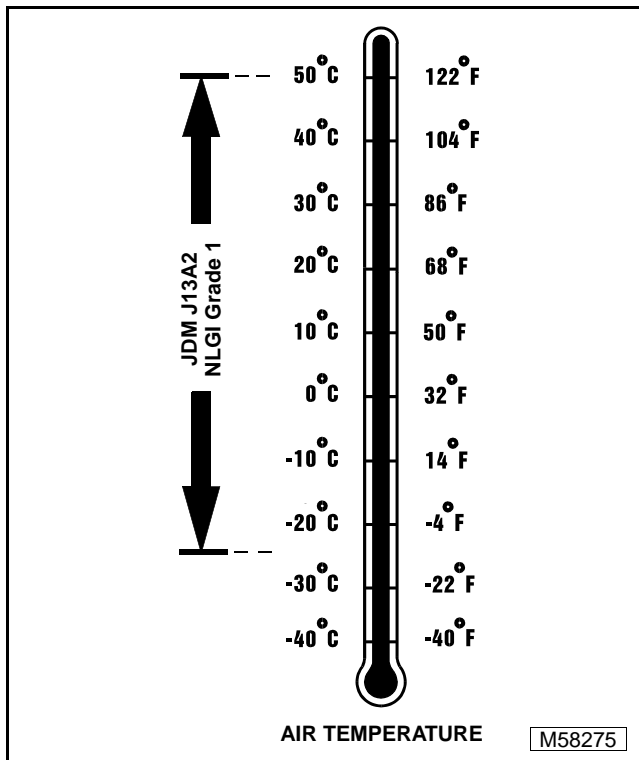

**John Deere Dealers:** You may want to cross-reference the following publications to recommend the proper grease for your customers:

- Module DX,GREA1 in JDS–G135;
- Section 530, Lubricants & Hydraulics, of the John Deere Merchandise Sales Guide;
- the Lubrication Sales Manual PI7032.

## ALTERNATIVE LUBRICANTS

Conditions in certain geographical areas outside the United States and Canada may require different lubricant recommendations than the ones printed in this technical manual or the operator's manual. Consult with your John Deere Dealer, or Sales Branch, to obtain the alternative lubricant recommendations.

**IMPORTANT: Use of alternative lubricants could cause reduced life of the component.**

If alternative lubricants are to be used, it is recommended that the factory fill be thoroughly removed before switching to any alternative lubricant.

## SYNTHETIC LUBRICANTS

Synthetic lubricants may be used in John Deere equipment if they meet the applicable performance requirements (industry classification and/or military specification) as shown in this manual.

The recommended air temperature limits and service or lubricant change intervals should be maintained as shown in the operator's manual.

Avoid mixing different brands, grades, or types of oil. Oil manufacturers blend additives in their oils to meet certain specifications and performance requirements. Mixing different oils can interfere with the proper functioning of these additives and degrade lubricant performance.

## LUBRICANT STORAGE

All machines operate at top efficiency only when clean lubricants are used. Use clean storage containers to handle all lubricants. Store them in an area protected from dust, moisture, and other contamination. Store drums on their sides. Make sure all containers are properly marked as to their contents. Dispose of all old, used containers and their contents properly.

## MIXING OF LUBRICANTS

In general, avoid mixing different brands or types of lubricants. Manufacturers blend additives in their lubricants to meet certain specifications and performance requirements. Mixing different lubricants can interfere with the proper functioning of these additives and lubricant properties which will downgrade their intended specified performance.

## OIL FILTERS

**IMPORTANT: Filtration of oils is critical to proper lubrication performance. Always change filters regularly.**

The following John Deere oil filters are PREFERRED:

- AUTOMOTIVE AND LIGHT TRUCK ENGINE OIL FILTERS.

Most John Deere filters contain pressure relief and anti-drainback valves for better engine protection.

Other oil filters may be used if above recommended John Deere oil filters are not available, provided they meet the following specification:

- ASTB Tested In Accordance With SAE J806.

**John Deere Dealers:** You may want to cross-reference the following publications to recommend the proper oil filter for your customers:

- Module DX, FILT in JDS–G135;
- Section 540, Lubricants & Hydraulics, of the John Deere Merchandise Sales Guide;
- Lawn & Grounds Care Tune-Up Guide PI672.

### SERIAL NUMBER INFORMATION

When working on machines or components that are covered by warranty, it is IMPORTANT that you include the machine's Product Identification Number and the component serial number on the warranty claim form.

The location of component serial number plates are shown below.

### PRODUCT IDENTIFICATION NUMBER LOCATION



The Commercial Walk-Behind Power Unit Product Identification Number is located on the right hand side of the drive train housing.

### ENGINE SERIAL NUMBER LOCATION - KAWASAKI ENGINES



The engine serial number is located on the Fan Housing opposite the engine head.

### ENGINE SERIAL NUMBER LOCATION - KOHLER ENGINE

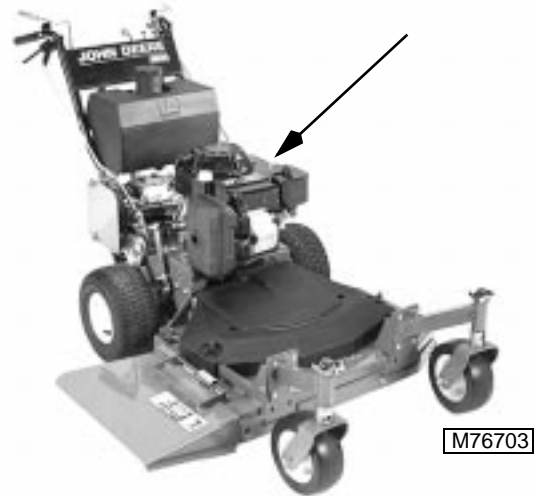

The engine serial number is located on the Fan Housing next to the carburetor intake air filter cover.

### GEAR TRANSMISSION SERIAL NUMBER LOCATION



The gear transmission serial number is located on the transmission housing web.

**HYDROSTATIC TRANSAXLE SERIAL NUMBER LOCATION**

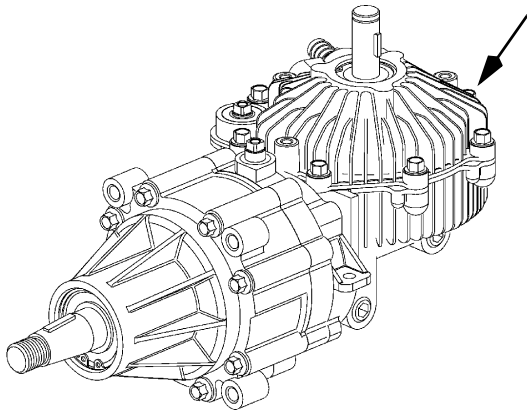

The hydrostatic transaxle serial number tag is bolted to the inside edge of the transaxle case, and can be seen from the rear of the mower deck.

**MOWER DECK SERIAL NUMBER LOCATION—48/54 INCH**



The Mower Deck Product Identification Number is located on the left hand side of the mower deck.

**MOWER DECK SERIAL NUMBER LOCATION—36 INCH**



The Mower Deck Product Identification Number is located on the left hand side of the mower deck.

# CONTENTS

Page

## KAWASAKI ENGINES

<b>SPECIFICATIONS</b> .....	<b>5</b>
TEST AND ADJUSTMENT SPECIFICATIONS—KAWASAKI ENGINES .....	5
REPAIR SPECIFICATIONS .....	6
TORQUE SPECIFICATIONS .....	9
ESSENTIAL TOOLS .....	9
OTHER MATERIAL .....	9
<b>COMPONENT LOCATION</b> .....	<b>10</b>
CARBURETOR COMPONENT LOCATION-FC401V-BS05, FC420V-AS19 & AS21	10
CARBURETOR COMPONENT LOCATION—FC540V-AS17 & AS18. ....	11
INTAKE SYSTEM COMPONENT LOCATION—ALL .....	12
ENGINE - EXTERNAL COMPONENT LOCATION .....	13
ENGINE - INTERNAL COMPONENT LOCATION. ....	14
RECOIL STARTER COMPONENT LOCATION. ....	15
ELECTRIC STARTER COMPONENT LOCATION .....	16
<b>THEORY OF OPERATION</b> .....	<b>17</b>
COOLING SYSTEM OPERATION. ....	17
AUTOMATIC COMPRESSION RELEASE (ACR) OPERATION .....	18
CRANKCASE BREATHER SYSTEM OPERATION. ....	19
LUBRICATION SYSTEM OPERATION .....	20
FUEL SYSTEM OPERATION .....	21
<b>TROUBLESHOOTING</b> .....	<b>22</b>
CARBURETION TROUBLESHOOTING .....	22
ENGINE TROUBLESHOOTING .....	23
ENGINE TROUBLESHOOTING GUIDE .....	25
ENGINE HARD TO START .....	25
ENGINE MALFUNCTIONS AT LOW SPEED .....	26
ENGINE RUNS ERRATICALLY .....	27
OIL CONSUMPTION IS EXCESSIVE .....	27
ENGINE HAS LOW POWER. ....	28
FUEL CONSUMPTION IS EXCESSIVE .....	28
STARTING MOTOR TROUBLESHOOTING GUIDE .....	29
STARTING MOTOR DOES NOT ROTATE .....	29
STARTING MOTOR ROTATES SLOWLY .....	29
STARTING MOTOR ROTATES BUT CAN NOT CRANK ENGINE. ....	29
STARTING MOTOR DOES NOT STOP WITH KEY SWITCH IN OFF POSITION ..	29
<b>TESTS AND ADJUSTMENTS</b> .....	<b>30</b>
FLYWHEEL SCREEN ADJUSTMENT .....	30
VALVE CLEARANCE ADJUSTMENT .....	31
FUEL PUMP TEST .....	32
THROTTLE CABLE ADJUSTMENT .....	33
CHOKE ADJUSTMENT. ....	34
GOVERNOR ADJUSTMENT. ....	35
FAST IDLE SPEED ADJUSTMENT .....	35





	Page
CYLINDER COMPRESSION TEST . . . . .	36
COMPRESSION LEAK CHECK . . . . .	37
AUTOMATIC COMPRESSION RELEASE (ACR) CHECK . . . . .	37
CRANKCASE VACUUM TEST . . . . .	38
OIL PRESSURE TEST . . . . .	38
SLOW IDLE SPEED ADJUSTMENT	
CARB/EPA ENGINES . . . . .	39
SLOW IDLE MIXTURE ADJUSTMENT	
CARB/EPA ENGINES . . . . .	41
IGNITION COIL WITH MODULE AIR GAP ADJUSTMENT . . . . .	43
IGNITION COIL WITH MODULE TEST . . . . .	44
SPARK PLUG GAP ADJUSTMENT . . . . .	44
SPARK TEST . . . . .	45
<b>REPAIR . . . . .</b>	<b>45</b>
ENGINE REMOVAL . . . . .	45
ENGINE INSTALLATION . . . . .	46
FUEL PUMP REMOVAL & INSTALLATION . . . . .	47
CARBURETOR REMOVAL . . . . .	48
CARBURETOR INSTALLATION . . . . .	49
CARBURETOR DISASSEMBLY, CLEAN, INSPECT AND ASSEMBLY . . . . .	50
BREATHER REMOVAL, INSPECTION & REPLACEMENT . . . . .	50
BLOWER HOUSING REMOVAL & INSTALLATION . . . . .	51
ROCKER ARM ASSEMBLY REMOVAL & INSTALLATION . . . . .	52
ROCKER ARM ASSEMBLY INSPECTION . . . . .	53
PUSH ROD INSPECTION . . . . .	53
CYLINDER HEAD REMOVAL . . . . .	53
CYLINDER HEAD INSTALLATION . . . . .	54
CYLINDER HEAD INSPECTION . . . . .	54
VALVES AND SPRINGS REMOVAL AND INSTALLATION . . . . .	54
VALVE STEM SEAL REPLACEMENT . . . . .	55
VALVE SPRING INSPECTION . . . . .	55
VALVE INSPECTION . . . . .	55
VALVE ANALYZE . . . . .	56
VALVE GUIDE INSPECTION . . . . .	57
VALVE GUIDE REPLACEMENT . . . . .	58
VALVE SEAT RECONDITIONING . . . . .	58
LAP VALVES . . . . .	59
FLYWHEEL REMOVAL AND INSTALLATION . . . . .	59
CRANKCASE COVER REMOVAL . . . . .	60
CRANKCASE COVER INSTALLATION . . . . .	60
CRANKCASE PLAIN BEARINGS . . . . .	61
CRANKCASE COVER SEAL . . . . .	61
CAMSHAFT REMOVAL AND INSTALLATION . . . . .	62
CAMSHAFT INSPECTION . . . . .	62
CAMSHAFT BEARINGS . . . . .	63

	Page
AUTOMATIC COMPRESSION RELEASE (ACR) INSPECTION . . . . .	63
TAPPETS REMOVAL AND INSTALLATION . . . . .	63
BALANCER REMOVAL AND INSTALLATION . . . . .	64
BALANCER DISASSEMBLY AND ASSEMBLY . . . . .	65
BALANCER INSPECTION . . . . .	65
BALANCER BUSHINGS REPLACEMENT . . . . .	66
REMOVE PISTON AND CONNECTING ROD . . . . .	66
PISTON INSTALLATION . . . . .	66
PISTON RINGS REMOVAL AND INSTALLATION . . . . .	67
CHECK PISTON RING END GAP . . . . .	67
PISTON INSPECTION . . . . .	67
CRANKSHAFT AND CONNECTING ROD WEAR INSPECTION . . . . .	68
PISTON-TO-ROD ASSEMBLY . . . . .	68
INSPECT CONNECTING ROD . . . . .	69
INSPECT CRANKSHAFT . . . . .	69
CRANKSHAFT BALL BEARING REPLACEMENT . . . . .	70
CHECK CRANKSHAFT ALIGNMENT (TIR) . . . . .	70
CRANKSHAFT END PLAY ADJUSTMENT . . . . .	71
BLOCK INSPECTION . . . . .	71
DEGLAZE CYLINDER BORE . . . . .	72
REBORE CYLINDER BLOCK . . . . .	72
OIL FILTER MANIFOLD REMOVAL AND INSTALLATION . . . . .	72
OIL PUMP REMOVAL AND INSTALLATION . . . . .	73
OIL PUMP INSPECTION . . . . .	73
GOVERNOR SHAFT INSPECT AND REPLACE . . . . .	75
GOVERNOR REMOVAL AND INSTALLATION . . . . .	75
STATOR REMOVAL AND INSTALLATION . . . . .	76
IGNITION COIL WITH MODULE REMOVAL AND INSTALLATION . . . . .	76
STARTING MOTOR REMOVAL . . . . .	77
STARTING MOTOR PROBLEM DIAGNOSIS . . . . .	77
STARTING MOTOR BENCH TEST . . . . .	77
SOLENOID TEST . . . . .	78
STARTING MOTOR ROTATION TEST . . . . .	78
STARTING MOTOR DISASSEMBLY/ASSEMBLY . . . . .	78
STARTING MOTOR INSPECTION . . . . .	78
STARTING MOTOR FIELD COIL TEST . . . . .	80
RECOIL STARTER DISASSEMBLY . . . . .	80
RECOIL STARTER SPRING REPLACEMENT . . . . .	81
RECOIL STARTER ASSEMBLY . . . . .	82





## SPECIFICATIONS

### TEST AND ADJUSTMENT SPECIFICATIONS—KAWASAKI ENGINES

#### Valves

Valve Clearance . . . . . 0.15 mm (0.006 in.)

#### Flywheel And Breather

Breather Air Gap . . . . . 1—2 mm (0.040—0.080 in.)

Minimum Flywheel Screen Gap . . . . . 1.50 mm (0.059 in.)

Crankcase Vacuum @ 3350 rpm . . . . . 25 cm (10 in.) water

#### Automatic Compression Release (ACR)

Minimum Exhaust Valve Movement . . . . . 0.25 mm (0.010 in.)

#### Lubrication System

##### Oil Capacity With Filter

FC401V-BS05 & FC420V-AS19 & AS21 . . . . . 1.5 L (3.17 pt.)

FC540V-AS17 & AS18 . . . . . 1.9 L (4.0 pt.)

##### Without Filter

FC401V-BS05 & FC420V-AS19 & AS21 . . . . . 1.3 L (2.75 pt.)

FC540V-AS17 & AS18 . . . . . 1.6 L (3.38 pt.)

#### Oil Pump

Minimum Oil Pressure @ 3350 rpm . . . . . 240 kPa (35 psi)

#### Fuel Pump

Fuel Pump Pressure Minimum . . . . . 6.21 kPa (0.9 psi)

Minimum Flow In 15 seconds @3350 Engine rpm

FC401V-BS05 & FC420V-AS19 & AS21 . . . . . 80 mL (2.7 oz.)

FC540V-AS17 & AS18 . . . . . 90 mL (3 oz.)

#### Ignition And Charging System

Ignition Coil With Module Air Gap . . . . . 0.30 mm (0.012 in.)

Spark Plug Gap . . . . . 0.76 mm (0.030 in.)

#### Fuel/Air System

Throttle Lever Stop Gap . . . . . 2—4 mm (0.080—0.160 in.)

Choke Cable Clearance (Knob To Plastic Boot) . . . . . 2—3 mm (0.080—0.120 in.)

#### Operating Specifications

Slow Idle Speed . . . . . 1450±75 rpm

Fast Idle Speed (No Load) . . . . . 3350±100 rpm

Direction of Rotation . . . . . Counterclockwise, Facing PTO Shaft



## REPAIR SPECIFICATIONS

### Valve

Intake Valve Lift (W/ Clearance set at 0.00)	8.99 mm (0.354 in.)
Exhaust Valve Lift (W/ Clearance set at 0.00)	8.99 mm (0.354 in.)
Valve Guide I.D.	
Min.	7.00 mm (0.275 in.)
Max.	7.02 mm (0.276 in.)
Replace if over.	7.07 mm (0.278 in.)
Valve Seating Surface	1.00—1.46 mm (0.039—0.057 in.)
Valve Seat and Face Angle	45°
Minimum Valve Margin	0.60 mm (0.020 in.)
Valve Narrowing Angle	30°
Intake Valve Stem O.D.	Min. 6.93 mm (0.272 in.)
	Max. 6.99 mm (0.275 in.)
Exhaust Valve Stem O.D.	Min. 6.91 mm (0.272 in.)
	Max. 6.98 mm (0.275 in.)
Maximum Valve Stem Bend	0.03 mm (0.001 in.)

### Valve Guide

Valve Guide I.D.	
Min.	7.00 mm (0.275 in.)
Max.	7.02 mm (0.276 in.)
Replace if over.	7.07 mm (0.278 in.)
Installed Height	
FC401V-BS05, FC420V-AS19 & AS21	12.0±0.1 mm (0.472±0.004 in.)
FC540V-AS17 & AS18	9.5±0.1 mm (0.374±0.004 in.)

### Rocker Arm

Minimum Shaft O.D.	12.94 mm (0.509 in.)
Maximum Rocker Arm Bore I.D.	13.07 mm (0.515 in.)

### Push Rod

Maximum Bend	0.30 mm (0.012 in.)
--------------	---------------------

### Springs:

Minimum Spring Free Length	37.50 mm (1.476 in.)
Squareness	2.39 mm (0.090 in.)

### Cylinder Head

Cylinder Head Flatness	0.05 mm (0.002 in.)
------------------------	---------------------

### Governor

Shaft Height (From Block)	32.2—32.8 mm (1.267—1.291 in.)
---------------------------	--------------------------------

**Camshaft And Tappets**

Camshaft Minimum End Journal O.D.	
PTO Side . . . . .	20.91 mm (0.823 in.)
Flywheel Side . . . . .	19.91 mm (0.784 in.)
Minimum Lobe Height . . . . .	36.75 mm (1.446 in.)
Maximum Bearing I.D. FC401V-BS05 & FC420V-AS19 & AS21	
Crankcase . . . . .	20.08 mm (0.790 in.)
Crankcase Cover . . . . .	21.08 mm (0.830 in.)
Maximum Bearing I.D. FC540V-AS17 & AS18	
Crankcase . . . . .	21.08 mm (0.830 in.)
Crankcase Cover . . . . .	21.08 mm (0.830 in.)



**Balancers**

Link Rod FC401V-BS05 & FC420V-AS19 & AS21	
Minimum Journal O.D. . . . .	53.95 mm (2.124 in.)
Maximum Small End I.D. . . . .	12.60 mm (0.475 in.)
Maximum Large End I.D. . . . .	54.12 mm (2.132 in.)
Bushing Depth . . . . .	1.00 mm (0.020 in.)
Link Rod FC540V-AS17 & AS18	
Minimum Journal O.D. . . . .	57.94mm (2.281 in.)
Maximum Small End I.D. . . . .	12.60 mm (0.475 in.)
Maximum Large End I.D. . . . .	58.15 mm (2.289 in.)
Bushing Depth . . . . .	1.00 mm (0.040 in.)
Balancer Weight	
Maximum Bearing I.D. . . . .	26.10 mm (1.027 in.)
Bushing Depth . . . . .	0.50 mm (0.02 in.)
Support Shaft Minimum Shaft O.D. . . . .	25.93 mm (1.021 in.)

**Piston**

Piston O.D. . . . .	88.83—88.86 mm (3.488—3.498 in.)
Maximum Ring Groove Clearance	
Top Ring . . . . .	0.17 mm (0.007 in.)
Second Ring . . . . .	0.15 mm (0.006 in.)
Oil Ring . . . . .	0.20 mm (0.008 in.)
Minimum Ring End Gap . . . . .	0.18 mm (0.007 in.)
Maximum Ring End Gap	
Compression Rings . . . . .	0.90 mm (0.035 in.)
Oil Ring . . . . .	1.30 mm (0.051 in.)
Minimum Pin O.D. . . . .	18.98 mm (0.747 in.)
Maximum Pin Bore I.D. . . . .	19.06 mm (0.750 in.)
Maximum Piston-to-Piston Pin Clearance . . . . .	0.06 mm (0.002 in.)

**Connecting Rod**

Maximum Crankshaft Bearing I.D. . . . .	41.07 mm (1.617 in.)
Maximum Piston Pin Bearing I.D. . . . .	19.06 mm (0.750 in.)
Maximum Connecting Rod-to-Piston Pin Clearance . . . . .	0.06 mm (0.002 in.)
Maximum Connecting Rod-to-Crankpin Clearance . . . . .	0.14 mm (0.006 in.)

Product: John Deere GS25, GS30, GS45, GS75, HD45, HD75 Commercial Walk-Behind Mowers Service Repair Technical Manual

Full Download: <https://www.bobmanualstore.com/downloads/john-deere-gs25-gs30-gs45-gs75hd45-hd75-commercial-walk-behind-mowers-service-repair-technical-manual>

0-gs45-gs75hd45-hd75-commercial-walk-behind-mowers-service-repair-technical-manual

**Crankshaft**

Minimum Main Bearing Journal O.D. - PTO Side.	
FC401V-BS05 & FC420V-AS19 & AS21	34.91 mm (1.374 in.)
FC540V-AS17 & AS18	37.90 mm (1.492 in.)
Minimum Main Bearing Journal O.D. - Flywheel Side (All)	34.94 mm (1.376 in.)
Minimum Connecting Rod Journal O.D.	40.93 mm (1.611 in.)
Maximum Crankcase Cover Plain Bearing I.D.	
FC401V-BS05 & FC420V-AS19 & AS21	35.06 mm (1.380 in.)
FC540V-AS17 & AS18	38.06 mm (1.498 in.)
Maximum T.I.R.	0.05 mm (0.002 in.)
End Play	0.09—0.22 mm (0.004—0.009 in.)

**Cylinder Block**

Cylinder Bore	
Standard Cylinder Bore I.D.	88.98—89.00 mm (3.500—3.504 in.)
Maximum Cylinder Bore I.D.	89.08 mm (3.507 in.)
Maximum Out Of Round	0.06 mm (0.002 in.)
Rebore Cylinder	
Oversize: 0.25 mm (0.010 in.)	89.21—89.23 mm (3.512—3.513 in.)
Oversize: 0.50 mm (0.020 in.)	89.46—89.48 mm (3.522—3.523 in.)
Oversize: 0.75 mm (0.030 in.)	89.71—89.73 mm (3.532—3.533 in.)
Final Honed Cylinder Bore	
Oversize: 0.25 mm (0.010 in.)	89.23—89.25 mm (3.513—3.514 in.)
Oversize: 0.50 mm (0.020 in.)	89.48—89.50 mm (3.523—3.524 in.)
Oversize: 0.75 mm (0.030 in.)	89.73—89.75 mm (3.533—3.534 in.)
Compression	483 kPa (71 psi)

**Oil Pump**

Minimum Rotor Shaft O.D.	
Large O.D.	12.63 mm (0.497 in.)
Small O.D.	7.94 mm (0.313 in.)
Maximum Rotor Shaft Bearing I.D.	
Oil Pump Cover	12.76 mm (0.502 in.)
Crankcase Cover	8.07 mm (0.318 in.)
Outer Rotor Thickness Max.	
FC401V-BS05 & FC420V-AS19 & AS21	11.92 mm (0.469 in.)
FC540V-AS17 & AS18	9.92 mm (0.391 in.)
Outer Rotor Housing I.D. Max.	
FC401V-BS05 & FC420V-AS19 & AS21	29.2 mm (1.150 in.)
FC540V-AS17 & AS18	40.72 mm (1.603 in.)
Outer Rotor O.D. Max.	
FC401V-BS05 & FC420V-AS19 & AS21	28.95 mm (1.140 in.)
FC540V-AS17 & AS18	40.47 mm (1.593 in.)
Minimum Valve Spring Free Length	19.00 mm (0.750 in.)

**Carburetor**

Float to jet holder	13.5—15.5 mm (0.531—0.610 in.)
---------------------	--------------------------------

**Starting Motor**

Minimum Brush Length	10.5 mm (0.413 in.)
----------------------	---------------------

Sample manual. Download All 344 pages at:

<https://www.bobmanualstore.com/downloads/john-deere-gs25-gs30-gs45-gs75hd45-hd75-commercial-walk-behind-mowers-service-repair-technical-manual>