

Product: John Deere 4000 Series Compact Utility Tractor Attachments Service Repair Technical Manual

Full Download: <https://www.bobmanualstore.com/downloads/john-deere-4000-ser>

[ies-compact-utility-tractor-attachments-service-repair-technical-manual/](https://www.bobmanualstore.com/downloads/john-deere-4000-series-compact-utility-tractor-attachments-service-repair-technical-manual/)

4000 Series Compact Utility Tractor Attachments

TECHNICAL MANUAL

**John Deere
Worldwide Commercial and
Consumer Equipment Division**

TM1763 (Jul99)

Sample manual. Download All 150 pages at:

<https://www.bobmanualstore.com/downloads/john-deere-4000-series-compact-utility-tractor-attachments-service-repair-technical-manual/>

Litho in U.S.A

Product: John Deere 4000 Series Compact Utility Tractor Attachments Service Repair Technical Manual
Full Download: <https://www.bobmanualstore.com/downloads/john-deere-4000-series-compact-utility-tractor-attachments-service-repair-technical-manual/>

**47 and 48 Backhoes;
54, 60 and 72-Inch Mid Mount Rotary Mowers;
450, 550, 660, 670 and 680 Hydraulic Tillers;
31B Post Hole Digger;
74 and 84 Front Blades;
26 and 51-Inch Brooms;
47 and 59 Snowblowers;
261 and 271 Rear-Mounted Rotary Mowers**

Sample manual. Download All 150 pages at:

<https://www.bobmanualstore.com/downloads/john-deere-4000-series-compact-utility-tractor-attachments-service-repair-technical-manual/>

This technical manual is written for an experienced technician and contains sections that are specifically for this product. It is a part of a total product support program.

The manual is organized so that all the information on a particular system is kept together. The order of grouping is as follows:

- Table of Contents
- Specifications
- Component Location
- System Schematic
- Theory of Operation
- Troubleshooting Chart
- Diagnostics
- Tests & Adjustments
- Repair









Note: Depending on the particular section or system being covered, not all of the above groups may be used.

Each section will be identified with a symbol rather than a number. The groups and pages within a section will be consecutively numbered.

We appreciate your input on this manual. To help, there are postage paid post cards included at the back. If you find any errors or want to comment on the layout of the manual please fill out one of the cards and mail it back to us.

All information, illustrations and specifications in this manual are based on the latest information available at the time of publication. The right is reserved to make changes at any time without notice.

COPYRIGHT© 1999
 Deere & Co.
 John Deere Worldwide Commercial and
 Consumer Equipment Division
 Horicon, WI
 All rights reserved

Safety	
Specifications and Information	
Backhoes	
Rotary Mowers	
Rotary Tillers	
Post Hole Digger	
Blades	
Rotary Brooms	
Snowblowers	

Miscellaneous	M
----------------------	----------



RECOGNIZE SAFETY INFORMATION

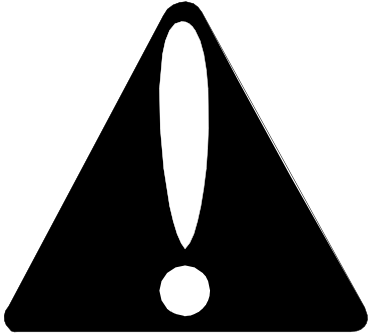

This is the safety-alert symbol. When you see this symbol on your machine or in this manual, be alert to the potential for personal injury.

Follow recommended precautions and safe servicing practices.

Understand Signal Words

A signal word—DANGER, WARNING, or CAUTION—is used with the safety-alert symbol. DANGER identifies the most serious hazards.

DANGER or WARNING safety signs are located near specific hazards. General precautions are listed on CAUTION safety signs. CAUTION also calls attention to safety messages in this manual.

REPLACE SAFETY SIGNS



TS201

Replace missing or damaged safety signs. See the machine operator's manual for correct safety sign placement.

HANDLE FLUIDS SAFELY-AVOID FIRES

Be Prepared For Emergencies



TS227

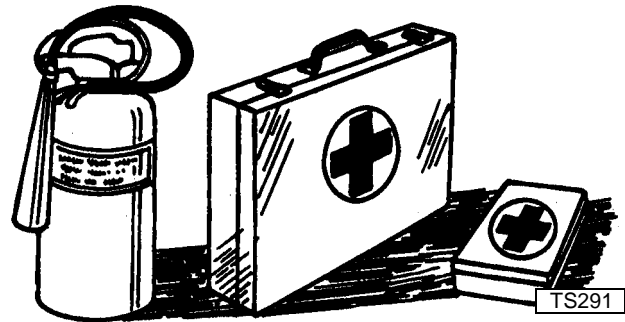

TS291

When you work around fuel, do not smoke or work near heaters or other fire hazards.

Store flammable fluids away from fire hazards. Do not incinerate or puncture pressurized containers.

Make sure machine is clean of trash, grease, and debris.

Do not store oily rags; they can ignite and burn spontaneously.

Be prepared if a fire starts.

Keep a first aid kit and fire extinguisher handy.

Keep emergency numbers for doctors, ambulance service, hospital, and fire department near your telephone.

USE CARE AROUND HIGH-PRESSURE FLUID LINES

Avoid High-pressure Fluids



Escaping fluid under pressure can penetrate the skin causing serious injury.

Avoid injury from escaping fluid under pressure by stopping the engine and relieving pressure in the system before disconnecting or connecting hydraulic or other lines. Tighten all connections before applying pressure.

Search for leaks with a piece of cardboard. Protect hands and body from high pressure fluids.

If an accident occurs, see a doctor immediately. Any fluid injected into the skin must be surgically removed within a few hours or gangrene may result. Doctors unfamiliar with this type of injury should reference a knowledgeable medical source. Such information is available from Deere & Company Medical Department in Moline, Illinois, U.S.A.

Avoid Heating Near Pressurized Fluid Lines



Flammable spray can be generated by heating near pressurized fluid lines, resulting in severe burns to yourself and bystanders. Do not heat by welding, soldering, or using a torch near pressurized fluid lines or other flammable materials. Pressurized lines can be accidentally cut when heat goes beyond the immediate flame area.

USE SAFE SERVICE PROCEDURES

Wear Protective Clothing

Wear close fitting clothing and safety equipment appropriate to the job.

Prolonged exposure to loud noise can cause impairment or loss of hearing. Wear a suitable hearing protective device such as earmuffs or earplugs to protect against objectionable or uncomfortable loud noises.

Operating equipment safely requires the full attention of the operator. Do not wear radio or music headphones while operating machine.



Service Machines Safely

Tie long hair behind your head. Do not wear a necktie, scarf, loose clothing, or necklace when you work near machine tools or moving parts. If these items were to get caught, severe injury could result.

Remove rings and other jewelry to prevent electrical shorts and entanglement in moving parts.

Use Proper Tools

Use tools appropriate to the work. Makeshift tools and procedures can create safety hazards. Use power tools only to loosen threaded parts and fasteners. For loosening and tightening hardware, use the correct size tools. **DO NOT** use U.S. measurement tools on metric fasteners. Avoid bodily injury caused by slipping wrenches. Use only service parts meeting John Deere specifications.



Park Machine Safely

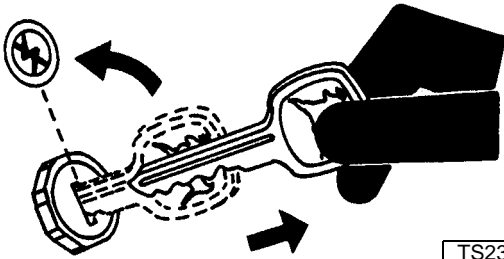

TS230

Before working on the machine:

1. Lower all equipment to the ground.
2. Stop the engine and remove the key.
3. Disconnect the battery ground strap.
4. Hang a "DO NOT OPERATE" tag in operator station.

Support Machine Properly And Use Proper Lifting Equipment

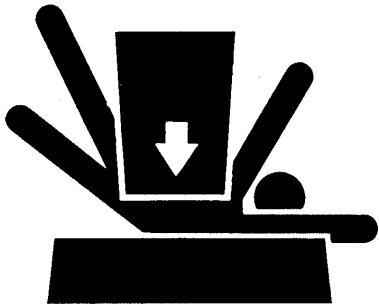

TS229

If you must work on a lifted machine or attachment, securely support the machine or attachment.

Do not support the machine on cinder blocks, hollow tiles, or props that may crumble under continuous load. Do not work under a machine that is supported solely by a jack. Follow recommended procedures in this manual.

Lifting heavy components incorrectly can cause severe injury or machine damage. Follow recommended procedure for removal and installation of components in the manual.

Work In Clean Area

Before starting a job:

1. Clean work area and machine.
2. Make sure you have all necessary tools to do your job.
3. Have the right parts on hand.
4. Read all instructions thoroughly; do not attempt shortcuts.

Using High Pressure Washers

Directing pressurized water at electronic/electrical components or connectors, bearings, hydraulic seals, fuel injection pumps or other sensitive parts and components may cause product malfunctions. Reduce pressure and spray at a 45 to 90 degree angle.

Illuminate Work Area Safely

Illuminate your work area adequately but safely. Use a portable safety light for working inside or under the machine. Make sure the bulb is enclosed by a wire cage. The hot filament of an accidentally broken bulb can ignite spilled fuel or oil.

Work In Ventilated Area

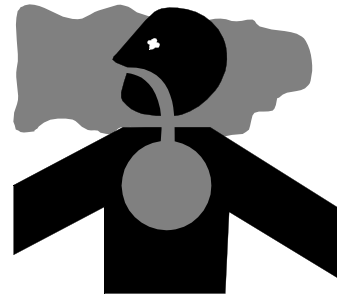

Engine exhaust fumes can cause sickness or death. If it is necessary to run an engine in an enclosed area, remove the exhaust fumes from the area with an exhaust pipe extension.

If you do not have an exhaust pipe extension, open the doors and get outside air into the area.

Remove Paint Before Welding Or Heating

Avoid potentially toxic fumes and dust. Hazardous fumes can be generated when paint is heated by welding, soldering, or using a torch. Do all work outside or in a well ventilated area. Dispose of paint and solvent properly. Remove paint before welding or heating: If you sand or grind paint, avoid breathing the dust. Wear an approved respirator. If you use solvent or paint stripper, remove stripper with soap and water before welding. Remove solvent or paint stripper containers and other flammable material from area. Allow fumes to disperse at least 15 minutes before welding or heating.

AVOID INJURY FROM ROTATING BLADES, AUGERS AND PTO SHAFTS

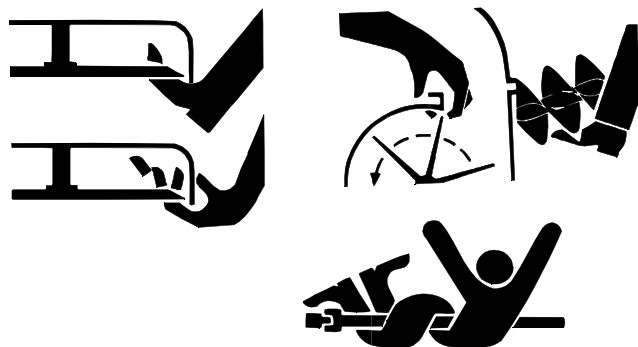

Keep hands and feet away while machine is running. Shut off power to service, lubricate or remove mower blades, augers or PTO shafts.

HANDLE CHEMICAL PRODUCTS SAFELY

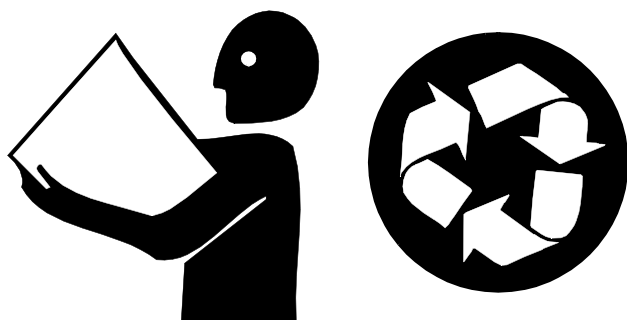

Direct exposure to hazardous chemicals can cause serious injury. Potentially hazardous chemicals used with John Deere equipment include such items as lubricants, coolants, paints, and adhesives.

A Material Safety Data Sheet (MSDS) provides specific details on chemical products: physical and health hazards, safety procedures, and emergency response techniques. Check the MSDS before you start any job using a hazardous chemical. That way you will know exactly what the risks are and how to do the job safely. Then follow procedures and recommended equipment.

Dispose of Waste Properly

Improperly disposing of waste can threaten the environment and ecology. Potentially harmful waste used with John Deere equipment include such items as oil, fuel, coolant, brake fluid, filters, and batteries. Use leakproof containers when draining fluids. Do not use food or beverage containers that may mislead someone into drinking from them. Do not pour waste onto the ground, down a drain, or into any water source. Inquire on the proper way to recycle or dispose of waste from your local environmental or recycling center, or from your John Deere dealer.



LIVE WITH SAFETY



Before returning machine to customer, make sure machine is functioning properly, especially the safety systems. Install all guards and shields.



CONTENTS

	Page
SPECIFICATIONS	3
BACKHOE SPECIFICATIONS.....	3
MOWERS	3
ROTARY TILLER SPECIFICATIONS.....	3
POST HOLE DIGGER SPECIFICATIONS	3
FRONT BLADE SPECIFICATIONS.....	3
ROTARY BROOM SPECIFICATIONS	4
SNOWBLOWER SPECIFICATIONS	4
ATTACHMENT USE.....	4
O-RING SEAL SERVICE RECOMMENDATIONS	5
FACE SEAL FITTINGS WITH INCH STUD ENDS TORQUE	5
FACE SEAL FITTINGS WITH METRIC STUD ENDS TORQUE.....	6
O-RING FACE SEAL FITTINGS	7
O-RING BOSS FITTINGS	7
INCH FASTENER TORQUE VALUES	8
METRIC FASTENER TORQUE VALUES	9
LUBRICANTS	10
HYDROSTATIC TRANSMISSION & HYDRAULIC OIL	10
ALTERNATIVE LUBRICANTS	10
LUBRICANT STORAGE	10
CHASSIS GREASE—NORTH AMERICA	11
CHASSIS GREASE—EUROPE	11





SPECIFICATIONS

BACKHOE SPECIFICATIONS

Dimensions:

Circuit Relief Valve Setting

Boom and Dipperstick	
47 Backhoe	19 980 ± 690 kPa (2600 ± 100 psi)
48 Backhoe	19 980 ± 690 kPa (2600 ± 100 psi)
Shim Sizes	
47 and 48 Backhoe	1.02 mm (0.04 in.), 0.51 mm (0.02 in.), 0.25 mm (0.01 in.)

MOWERS

All Mid-Mount Mowers

54 Inch Deck Blade Bolt Torque	57 - 84 N•m (42 - 62 lb-ft)
60/72 Inch Deck Blade Bolt Torque	102 - 123 N•m (75 - 91 lb-ft)

3-Point Hitch Rear Mount Mowers

Blade Bolt Torque	102 - 123 N•m (75 - 91 lb-ft)
261 and 272 Mounting	Category 1
261 and 272 PTO Speed	540 rpm

ROTARY TILLER SPECIFICATIONS

Models	450, 550, 660, 670 and 680
Chain Free Play	10 mm (0.375 in.)
PTO Spring Clutch Adjustment	28.9 - 29.5 mm (1.137 - 1.161 in.)
Gear Backlash (All Models)	0.2 - 0.6 mm (0.008 - 0.023 in.)
Chain Case Oil Level (approx) (All Models)	0.85 L (28 oz)
Gear Oil Level (approx) (All Models)	0.40 L (13.5 oz)
Gear Case Grease	John Deere GL-5 [®] Gear Oil-SAE 80W-90

POST HOLE DIGGER SPECIFICATIONS

Model	31B
Drive Type	PTO
PTO rpm (maximum)	540 rpm
Auger rpm (maximum)	170 rpm
Backlash	0.1 - 0.56 mm (0.004 - 0.022 in.)
Endplay	none
Transportation Clearance	20 - 25 cm (8 - 10 in.)
Weight (less auger)	77 kg (170 lbs)

FRONT BLADE SPECIFICATIONS

Lift Cylinder Lock Nut	272 N•m (200 lb-ft)
----------------------------------	---------------------



ROTARY BROOM SPECIFICATIONS

Gear Box Backlash 0.2 - 0.6 mm (0.008 - 0.023 in.)
 Input Shaft Endplay zero

SNOWBLOWER SPECIFICATIONS

Input Shaft End Play (maximum 0.08 mm (0.003 in.)
 Blower Case Shaft
 End Play 0.025 - 0.15 mm (0.001 - 0.006 in.)
 Backlash 0.15 - 0.4 mm (0.006 - 0.016 in.)
 Gear Box and Blower Case Grease Capacity
 59 0.4 L (13.5 oz)
 Blower Gear Case Half
 Socket Head Cap Screws 26 N•m (228 lb-in.)
 Cap Screws 41 N•m (34 lb-ft)

ATTACHMENT USE

ATTACHMENT	4100	4200	4300	4400	4500	4600
Backhoes:						
Model 47	N	Y	Y	Y	N	N
Backhoe Model 48	N	N	Y	Y	Y	Y
Mowers, Mid-Mount Rotary:						
54-inch mid mower	Y	N	N	N	N	N
60-inch mid mower	Y	Y	Y	Y	N	N
72-inch mid mower	N	Y	Y	Y	Y	Y
Mowers, 3-Point Hitch:						
261 60-inch	Y	Y	Y	Y	Y	Y
272 72-inch	Y	Y	Y	Y	Y	Y
Tillers:						
450 50-inch	Y	N	N	N	N	N
550 50-inch	Y	Y	Y	Y	Y	N ¹
660 60-inch	N	N	Y	Y	Y	Y
670 70-inch	N	N	N	N	Y	Y
680 80-inch	N	N	N	N	Y	Y
Post Hole Digger:						
31B	Y	Y	Y	Y	Y	Y
Blades, Front:						
74 54-inch, 60-inch, 66-inch	N ²	Y	Y	Y	N	N
84 84-inch	N	N	N	N	Y	Y
Rotary Brooms:						
51	Y	N	N	N	N	N
26	N	Y	Y	Y	N	N
Snowblowers:						
47-inch	Y	Y	N	N	N	N
59-inch	N	Y	Y	Y	N	N

¹ Tractor has too much horsepower for equipment.

² 54-Inch blade is available for use on 4100 tractor. Blade is separate from Model 75 54-inch blade.

O-RING SEAL SERVICE RECOMMENDATIONS

FACE SEAL FITTINGS WITH INCH STUD ENDS TORQUE

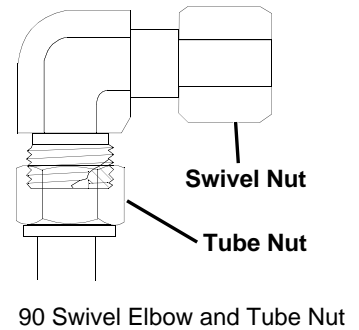
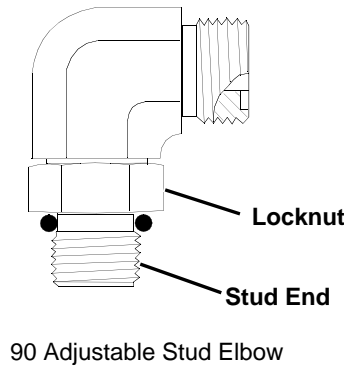
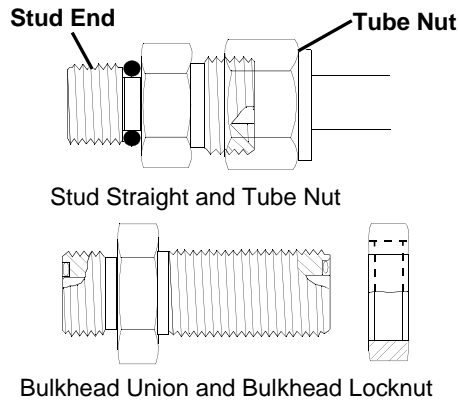

Nominal Tube O.D./Hose I.D.				Face Seal Tube/Hose End					O-ring Stud Ends		
Metric Tube O.D.	Inch Tube O.D.			Thread Size	Tube Nut/ Swivel Nut Torque		Bulkhead Locknut Torque		Thread Size	Straight Fitting or Locknut Torque	
	mm	Dash Size	in.		mm	in.	N•m	lb-ft		N•m	lb-ft
	-3	0.188	4.76						3/8-24	8	6
6	-4	0.250	6.35	9/16-18	16	12	12	9	7/16-20	12	9
8	-5	0.312	7.94						1/2-20	16	12
10	-6	0.375	9.52	11/16-16	24	18	24	18	9/16-18	24	18
12	-8	0.500	12.70	13/16-16	50	37	46	34	3/4-16	46	34
16	-10	0.625	15.88	1-14	69	51	62	46	7/8-14	62	46
	-12	0.750	19.05	1-3/16-12	102	75	102	75	1-1/16-12	102	75
22	-14	0.875	22.22	1-3/16-12	102	75	102	75	1-3/16-12	122	90
25	-16	1.000	25.40	1-7/16-12	142	105	142	105	1-5/16-12	142	105
32	-20	1.25	31.75	1-11/16-12	190	140	190	140	1-5/8-12	190	140
38	-24	1.50	38.10	2-12	217	160	217	160	1-7/8-12	217	160

NOTE: Torque tolerance is +15% / -20%.

FACE SEAL FITTINGS WITH METRIC STUD ENDS TORQUE

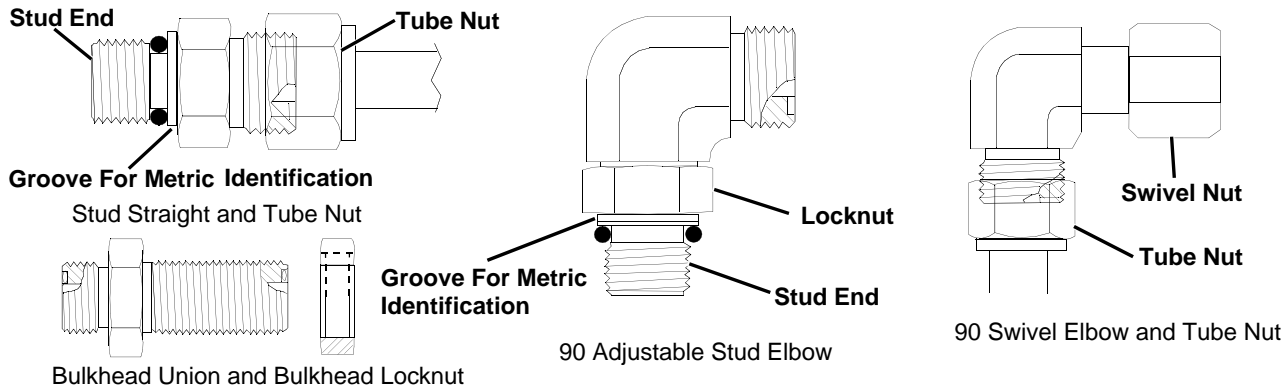

Nominal Tube O.D./Hose I.D.				Face Seal Tube/Hose End						O-ring Stud Ends, Straight Fitting or Locknut					
Metric Tube O.D.	Inch Tube O.D.			Thread Size	Hex Size	Tube Nut/ Swivel Nut Torque		Bulkhead Locknut Torque		Thread Size	Hex Size	Steel or Gray Iron Torque		Aluminum Torque	
	mm	Dash Size	in.			mm	in.	N•m	lb-ft			N•m	lb-ft	mm	mm
6	-4	0.250	6.35	9/16-18	17	16	12	12	9	M12X1.5	17	21	15.5	9	6.6
8	-5	0.312	7.94							M14X1.5	19	33	24	15	11
10	-6	0.375	9.52	11/16-16	22	24	18	24	18	M16X1.5	22	41	30	18	13
12	-8	0.500	12.70	13/16-16	24	50	37	46	34	M18X1.5	24	50	37	21	15
16	-10	0.625	15.88	1-14	30	69	51	62	46	M22X1.5	27	69	51	28	21
	-12	0.750	19.05	1-3/16-12	36	102	75	102	75	M27X2	32	102	75	46	34
22	-14	0.875	22.22	1-3/16-12	36	102	75	102	75	M30X2	36				
25	-16	1.000	25.40	1-7/16-12	41	142	105	142	105	M33X2	41	158	116	71	52
28										M38X2	46	176	130	79	58
32	-20	1.25	31.75	1-11/16-12	50	190	140	190	140	M42X2	50	190	140	85	63
38	-24	1.50	38.10	2-12	60	217	160	217	160	M48X2	55	217	160	98	72

NOTE: Torque tolerance is +15% / -20%.

O-RING FACE SEAL FITTINGS

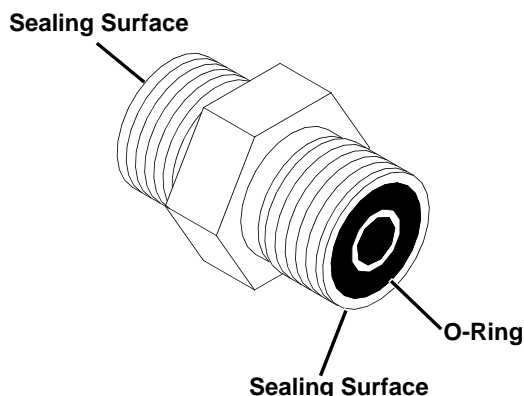

1. Inspect the fitting sealing surfaces. They must be free of dirt or defects.
2. Inspect the O-ring. It must be free of damage or defects.
3. Lubricate O-rings and install into groove using petroleum jelly to hold in place.
4. Push O-ring into the groove with plenty of petroleum jelly so O-ring is not displaced during assembly.
5. Index angle fittings and tighten by hand pressing joint together to insure O-ring remains in place.
6. Tighten fitting or nut to torque value shown on the chart per dash size stamped on the fitting. Do not allow hoses to twist when tightening fittings.

O-RING BOSS FITTINGS

1. Inspect boss O-ring boss seat. It must be free of dirt and defects. If repeated leaks occur, inspect for defects with a magnifying glass. Some raised defects can be removed with a slip stone.

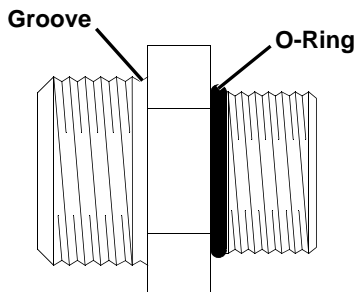

2. Put hydraulic oil or petroleum jelly on the O-ring. Place electrical tape over the threads to protect O-ring from nicks. Slide O-ring over the tape and into the groove of fitting. Remove tape.

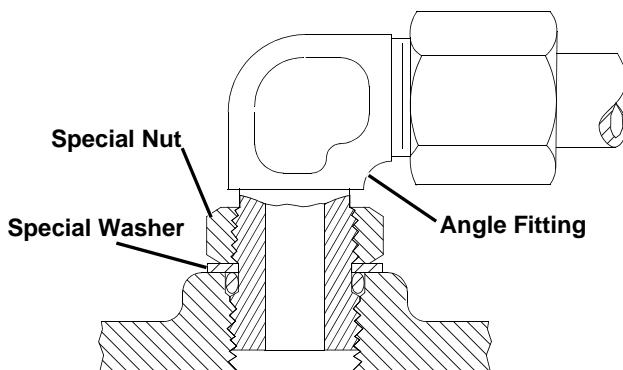

3. For angle fittings, loosen special nut and push special washer against threads so O-ring can be installed into the groove of fitting.
4. Turn fitting into the boss by hand until special washer or washer face (straight fitting) contacts boss face and O-ring is squeezed into its seat.
5. To position angle fittings, turn the fitting counter-clockwise a maximum of one turn.
6. Tighten straight fittings to torque value shown on chart. For angle fittings, tighten the special nut to value shown in the chart while holding body of fitting with a wrench.









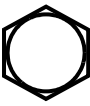

STRAIGHT FITTING OR SPECIAL NUT TORQUE

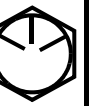
Thread Size	Torque ^a		Number of Flats ^b
	N•m	lb-ft	
3/8-24 UNF	8	(6)	2
7/16-20 UNF	12	(9)	2
1/2-20 UNF	16	(12)	2
9/16-18 UNF	24	(18)	2
3/4-16 UNF	46	(34)	2
7/8-14 UNF	62	(46)	1-1/2
1-1/16-12 UN	102	(75)	1
1-3/16-12 UN	122	(90)	1
1-5/16-12 UN	142	(105)	3/4
1-5/8-12 UN	190	(140)	3/4
1-7/8-12 UN	217	(160)	1/2

a. Torque tolerance is ± 10 percent.
 b. To be used if a torque wrench cannot be used. After tightening fitting by hand, put a mark on nut or boss; then tighten special nut or straight fitting the number of flats shown.

INCH FASTENER TORQUE VALUES



SAE Grade and Head Markings	1 or 2 ^b No Marks 	5  5.1  5.2 	8  8.2 
	2 No Marks 	5  	8  

TS1162

SIZE	Grade 1				Grade 2 ^b				Grade 5, 5.1 or 5.2				Grade 8 or 8.2			
	Lubricated ^a		Dry ^a		Lubricated ^a		Dry ^a		Lubricated ^a		Dry ^a		Lubricated ^a		Dry ^a	
	N•m	lb-ft	N•m	lb-ft	N•m	lb-ft	N•m	lb-ft	N•m	lb-ft	N•m	lb-ft	N•m	lb-ft	N•m	lb-ft
1/4	3.7	2.8	4.7	3.5	6	4.5	7.5	5.5	9.5	7	12	9	13.5	10	17	12.5
5/16	7.7	5.5	10	7	12	9	15	11	20	15	25	18	28	21	35	26
3/8	14	10	17	13	22	16	27	20	35	26	44	33	50	36	63	46
7/16	22	16	28	20	35	26	44	32	55	41	70	52	80	58	100	75
1/2	33	25	42	31	53	39	67	50	85	63	110	80	120	90	150	115
9/16	48	36	60	45	75	56	95	70	125	90	155	115	175	130	225	160
5/8	67	50	85	62	105	78	135	100	170	125	215	160	215	160	300	225
3/4	120	87	150	110	190	140	240	175	300	225	375	280	425	310	550	400
7/8	190	140	240	175	190	140	240	175	490	360	625	450	700	500	875	650
1	290	210	360	270	290	210	360	270	725	540	925	675	1050	750	1300	975
1-1/8	470	300	510	375	470	300	510	375	900	675	1150	850	1450	1075	1850	1350
1-1/4	570	425	725	530	570	425	725	530	1300	950	1650	1200	2050	1500	2600	1950
1-3/8	750	550	950	700	750	550	950	700	1700	1250	2150	1550	2700	2000	3400	2550
1-1/2	1000	725	1250	925	990	725	1250	930	2250	1650	2850	2100	3600	2650	4550	3350

DO NOT use these hand torque values if a different torque value or tightening procedure is given for a specific application. Torque values listed are for general use only and include a ±10% variance factor. Check tightness of fasteners periodically. DO NOT use air powered wrenches.

Shear bolts are designed to fail under predetermined loads. Always replace shear bolts with identical grade.

Fasteners should be replaced with the same grade. Make sure fastener threads are clean and that you properly start thread engagement. This will prevent them from failing when tightening.

When bolt and nut combination fasteners are used, torque values should be applied to the **NUT** instead of the bolt head.























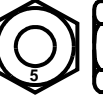

Tighten toothed or serrated-type lock nuts to the full torque value.

^a "Lubricated" means coated with a lubricant such as engine oil, or fasteners with phosphate and oil coatings. "Dry" means plain or zinc plated (yellow dichromate - Specification JDS117) without any lubrication.

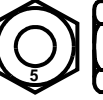
^b "Grade 2" applies for hex cap screws (not hex bolts) up to 152 mm (6-in.) long. "Grade 1" applies for hex cap screws over 152 mm (6-in.) long, and for all other types of bolts and screws of any length.

Reference: JDS—G200.

METRIC FASTENER TORQUE VALUES

Property Class and Head Markings	4.8		8.8		9.8		10.9			12.9			
													
Property Class and Nut Markings	5		10			10			12				
													

TS1163

SIZE	Class 4.8				Class 8.8 or 9.8				Class 10.9				Class 12.9			
	Lubricated ^a		Dry ^a		Lubricated ^a		Dry ^a		Lubricated ^a		Dry ^a		Lubricated ^a		Dry ^a	
	N•m	lb-ft	N•m	lb-ft	N•m	lb-ft	N•m	lb-ft	N•m	lb-ft	N•m	lb-ft	N•m	lb-ft	N•m	lb-ft
M6	48	3.5	6	4.5	9	6.5	11	8.5	13	9.5	17	12	15	11.5	19	14.5
M8	12	8.5	15	11	22	16	28	20	32	24	40	30	37	28	47	35
M10	23	17	29	21	43	32	55	40	63	47	80	60	75	55	95	70
M12	40	29	50	37	75	55	95	70	110	80	140	105	130	95	165	120
M14	63	47	80	60	120	88	150	110	175	130	225	165	205	150	260	109
M16	100	73	125	92	190	140	240	175	275	200	350	225	320	240	400	300
M18	135	100	175	125	260	195	330	250	375	275	475	350	440	325	560	410
M20	190	140	240	180	375	275	475	350	530	400	675	500	625	460	800	580
M22	260	190	330	250	510	375	650	475	725	540	925	675	850	625	1075	800
M24	330	250	425	310	650	475	825	600	925	675	1150	850	1075	800	1350	1000
M27	490	360	625	450	950	700	1200	875	1350	1000	1700	1250	1600	1150	2000	1500
M30	675	490	850	625	1300	950	1650	1200	1850	1350	2300	1700	2150	1600	2700	2000
M33	900	675	1150	850	1750	1300	2200	1650	2500	1850	3150	2350	2900	2150	3700	2750
M36	1150	850	1450	1075	2250	1650	2850	2100	3200	2350	4050	3000	3750	2750	4750	3500

DO NOT use these hand torque values if a different torque value or tightening procedure is given for a specific application. Torque values listed are for general use only and include a ±10% variance factor. Check tightness of fasteners periodically. DO NOT use air powered wrenches.

Shear bolts are designed to fail under predetermined loads. Always replace shear bolts with identical grade.

Fasteners should be replaced with the same grade. Make sure fastener threads are clean and that you properly start thread engagement. This will prevent them from failing when tightening.

When bolt and nut combination fasteners are used, torque values should be applied to the **NUT** instead of the bolt head.

Tighten toothed or serrated-type lock nuts to the full torque value.

^a "Lubricated" means coated with a lubricant such as engine oil, or fasteners with phosphate and oil coatings. "Dry" means plain or zinc plated (yellow dichromate - Specification JDS117) without any lubrication.

Reference: JDS—G200.

LUBRICANTS

HYDROSTATIC TRANSMISSION & HYDRAULIC OIL

Use the appropriate oil viscosity based on these air temperature ranges. Operating outside of these recommended oil air temperature ranges may cause premature hydrostatic transmission or hydraulic system failures.

IMPORTANT: Mixing of LOW VISCOSITY HY-GARD® and HY-GARD® oils is permitted. DO NOT mix any other oils in this transmission. DO NOT use engine oil or "Type F" (Red) Automatic Transmission Fluid in this transmission.

The following John Deere transmission and hydraulic oil is **PREFERRED**:

- **LOW VISCOSITY HY-GARD®—JDM J20D.**

The following John Deere oil is **also recommended** if above preferred oil is not available:

- **HY-GARD®—JDM J20C.**

Other oils may be used if above recommended John Deere oils are not available, provided they meet one of the following specifications:

- John Deere Standard JDM J20D;
- John Deere Standard JDM C.

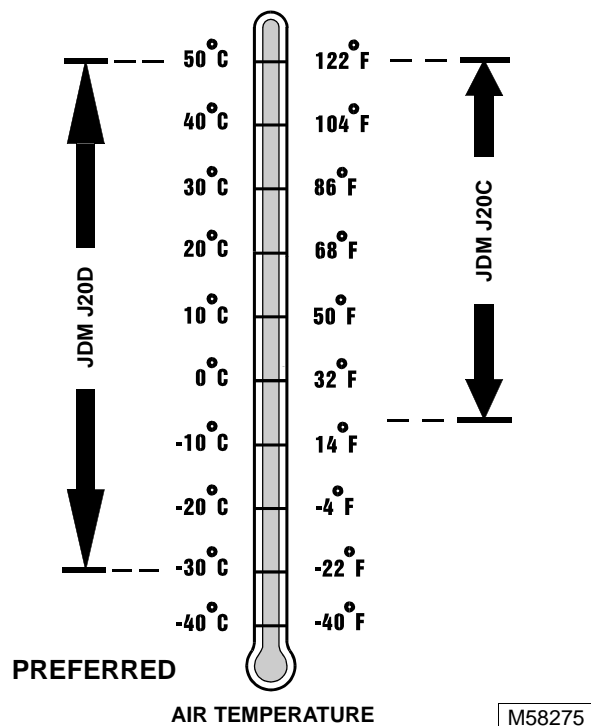

the following publications to recommend the proper oil for your customers:

- Module DX,ANTI in JDS-G135;
- Section 530, Lubricants & Hydraulics, of the John Deere Merchandise Sales Guide;
- Lubrication Sales Manual PI7032.

ALTERNATIVE LUBRICANTS

Conditions in certain geographical areas outside the United States and Canada may require different lubricant recommendations than these printed in this manual or the operator's manual. Consult with your John Deere Dealer, or Sales Branch to obtain the alternative lubricant recommendations.

LUBRICANT STORAGE

This machine can operate at top efficiency only if clean lubricants are used.

Use clean containers to handle all lubricants. Store them in an area protected from dust, moisture, and other contamination. Store drums on their sides.

John Deere Dealers: You may want to cross-reference

CHASSIS GREASE—NORTH AMERICA

IMPORTANT: ONLY use a quality grease in this application. DO NOT mix any other greases in this application. DO NOT use any BIO-GREASE in this application.

The following John Deere greases are **PREFERRED**:

- **MOLY HIGH-TEMPERATURE EP GREASE®—JDM J25C, NLGI Grade 2;**
- **HIGH-TEMPERATURE EP GREASE®—JDM J13E4, NLGI Grade 2.**

Other greases may be used if above preferred John Deere greases are not available, provided they meet one of the following specifications:

- **John Deere Standard JDM J25C, NLGI Grade 2;**
- **John Deere Standard JDM J13E4, NLGI Grade 2.**

IMPORTANT: If minimum air temperature should fall below -20 °C (-4 °F), the grease must be heated to at least five degrees above the lower limit before start-up or components may be damaged.

John Deere Dealers: You may want to cross-reference the following publications to recommend the proper grease for your customers:

- **Module DX,GREA1 in JDS-G135;**
- **Section 530, Lubricants & Hydraulics, of the John Deere Merchandise Sales Guide;**
- **the Lubrication Sales Manual PI7032.**

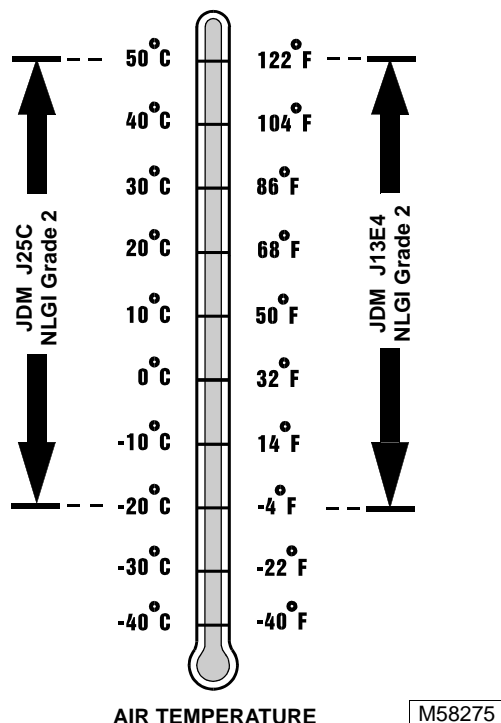

CHASSIS GREASE—EUROPE

IMPORTANT: ONLY use a quality grease in this application. DO NOT mix any other greases in this application. DO NOT use any BIO-GREASE in this application.

The following John Deere grease is **PREFERRED**:

- **GREASE-GARD™—JDM J25C, NLGI Grade 2.**

Other greases may be used if above preferred John Deere grease is not available, provided they meet the following specifications:

- **John Deere Standard JDM J25C, NLGI Grade 2.**

IMPORTANT: If minimum air temperature should fall below -10 °C (14 °F), the grease must be heated to at least five degrees above the lower limit before start-up or components may be damaged.

John Deere Dealers: You may want to cross-reference the following publications to recommend the proper grease for your customers:

- **Module DX,GREA1 in JDS-G135;**
- **Section 530, Lubricants & Hydraulics, of the John Deere Merchandise Sales Guide.**

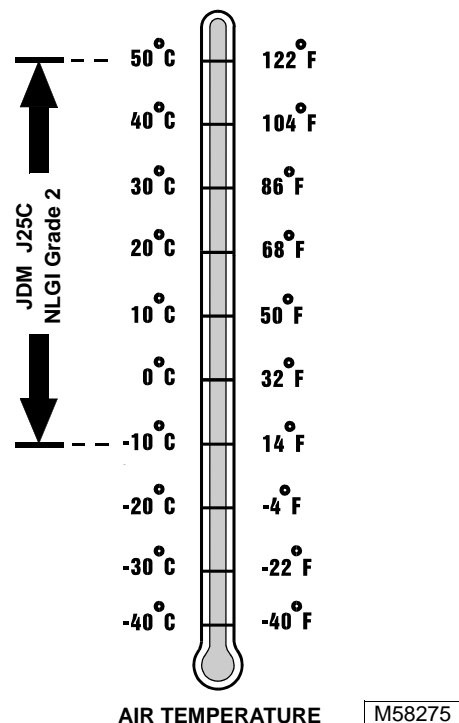



CONTENTS

	Page
SPECIFICATIONS	3
TORQUE SPECIFICATIONS	4
SPECIAL OR ESSENTIAL TOOLS	4
OTHER MATERIALS	4
BACKHOE COMPONENT LOCATION	5
47 BOOM	5
48 BOOM	6
THEORY OF OPERATION	7
CONTROL VALVES	7
LOAD CHECK VALVES	7
MAIN SYSTEM RELIEF VALVE	7
CIRCUIT RELIEF AND ANTI-CAVITATION CHECK VALVES	7
RESTRICTORS	7
BACKHOE HYDRAULIC SYSTEM	8
TROUBLESHOOTING	9
DIAGNOSTICS	12
TESTS AND ADJUSTMENTS	13
CIRCUIT RELIEF VALVE TESTS	13
MAIN SYSTEM RELIEF VALVE TEST	13
RESTRICTOR INSPECTION	14
ROCKSHAFT HEIGHT ADJUSTMENT (4200/4300/4400)	15
ROCKSHAFT HEIGHT ADJUSTMENT (4500/4600)	15
REPAIR	16
SYSTEM RELIEF VALVE INSPECTION	16
SPOOL REMOVAL	17
SPOOL ASSEMBLY	17
LOAD CHECK VALVES INSPECTION	18
DIPPERSTICK CIRCUIT RELIEF VALVE INSPECTION	18
ANTI-CAVITATION VALVE INSPECTION	18
BOOM CIRCUIT RELIEF VALVE INSPECTION	18
ASSEMBLE VALVE HOUSING	19
VALVE LINKAGE INSPECTION	20
VALVE HOUSING INSTALLATION	22
CYLINDER REMOVAL AND INSTALLATION	22
CYLINDER REPAIR	25
BOOM AND DIPPERSTICK CYLINDERS DISASSEMBLY AND REPAIR — 47 BACKHOE	25
BUCKET CYLINDERS DISASSEMBLY AND REPAIR — 47 BACKHOE	26
STABILIZER CYLINDER DISASSEMBLY AND REPAIR—47 BACKHOE	27
SWING CYLINDER DISASSEMBLY AND REPAIR—47 BACKHOE	28
BUCKET, BOOM, AND DIPPERSTICK CYLINDERS DISASSEMBLY AND REPAIR—48 BACKHOE	29
STABILIZER CYLINDERS DISASSEMBLY AND REPAIR—48 BACKHOE	30
SWING CYLINDERS DISASSEMBLY AND REPAIR—48 BACKHOE	31



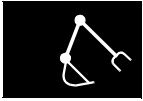

SPECIFICATIONS

Hydraulic Pump Flow Rate Capacity

4100 Tractor	27.66 L/min (7.3 gpm), Engine at 2650 rpm
4200 Tractor	27.6 L/min (7.3 gpm), Engine at 2600 rpm
4300 Tractor	31.4 L/min (8.3 gpm), Engine at 2600 rpm
4400 Tractor	31.4 L/min (8.3 gpm), Engine at 2600 rpm
4500 Tractor	37.5 L/min (9.9 gpm), Engine at 2600 rpm
4600 Tractor	39.0 L/min (10.3 gpm), Engine at 2700 rpm



Hydraulic Pump Working Pressure

4100 Tractor	16 671 kPa (2418 psi), Engine at 2650 rpm
4200 Tractor	14 650 kPa (2125 psi), Engine at 2600 rpm
4300 Tractor	17 235 kPa (2500 psi), Engine at 2600 rpm
4400 Tractor	17 235 kPa (2500 psi), Engine at 2600 rpm
4500 Tractor	17 235 kPa (2500 psi), Engine at 2600 rpm
4600 Tractor	17 235 kPa (2500 psi), Engine at 2700 rpm

Main System Relief Valve

Test Engine Speed	1500 rpm
Pressure	
47 Backhoe	15 515 [14 480 min.] kPa (2250 [2100 min.] psi)
48 Backhoe	17 580 [16 550 min] kPa (2550 [2400 min.] psi)

Circuit Relief Valve Setting

Boom and Dipperstick	
47 Backhoe	19 980 ± 690 kPa (2600 ±100 psi)
48 Backhoe	19 980 ± 690 kPa (2600 ±100 psi)
Shim Sizes	
47 and 48 Backhoe	1.02 mm (0.04 in.), 0.51 mm (0.02 in.), (0.254 mm (0.01 in.)

Restrictor Orifice ID

Boom	
47 Backhoe	1.575 mm (0.062 in.)
48 Backhoe	1.88 mm (0.074 in.)
Swing	
47 Backhoe	1.397 mm (0.055 in.)
48 Backhoe	1.88 mm (0.074 in.)
Stabilizer	
47 Backhoe	1.575 mm (0.062 in.)
48 Backhoe	1.88 mm (0.074 in.)

Internal Valve Leakage (Maximum acceptable limit)

Stabilizer Circuit	12 mL/min (0.73 cu in./min)
Lift Circuit (with relief and check)	22 mL/min (1.34 cu in./min)

**Cylinder Drop Rate
(Rod movement maximum acceptable limit from transport position)**

Lift Cylinder Drop Rate - 47.	14.48 mm/min (.57 in./min)
Lift Cylinder Drop Rate - 48.	9.15 mm/min (.36 in./min)
Stabilizer Cylinder Drop Rate - 47.	8.64 mm/min (.34 in./min)
Stabilizer Cylinder Drop Rate - 48.	5.85 mm/min (.23 in./min)
Stabilizer Cylinder Retract Rate - 47.	5.85 mm/min (.23 in./min)
Stabilizer Cylinder Retract Rate - 48.	3.81 mm/min (.15 in./min)

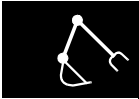

TORQUE SPECIFICATIONS

47 Backhoe

Boom and Dipper Stick Cylinder Lock Nut	353 N•m (260 lb-ft)
Bucket Cylinder Lock Nut	271 N•m (200 lb-ft)
Stabilizer Cylinder Lock Nut	190 N•m (140 lb-ft)
Swing Cylinder Lock Nut.	271 N•m (200 lb-ft)

48 Backhoe

Boom and Dipper Stick Cylinder Lock Nut	353 N•m (260 lb-ft)
Bucket Cylinder Lock Nut	353 N•m (260 lb-ft)
Stabilizer Cylinder Lock Nut	353 N•m (260 lb-ft)
Swing Cylinder Lock Nut.	353 N•m (260 lb-ft)

SPECIAL OR ESSENTIAL TOOLS

NOTE: Order tools according to information given in the U.S. SERVICE-GARD™ Catalog or in the European Microfiche Tool Catalog (MTC).

RECOMMENDED TOOLS

Number	Name	Use
D01018AA	Hydraulic Hand Pump	Used to test circuit relief valve pressure.
JTO70145	Hydraulic Test Gauge 0-20685 kPa (0-3000 psi)	Used to check main and circuit relief valve pressure.

OTHER MATERIALS

Number	Name	Use
592 / TY9375	LOCTITE® General Purpose Thread Sealant	Seal pipe plugs

LOCTITE® is a registered trademark of the Loctite Corp.

BACKHOE COMPONENT LOCATION

47 BOOM

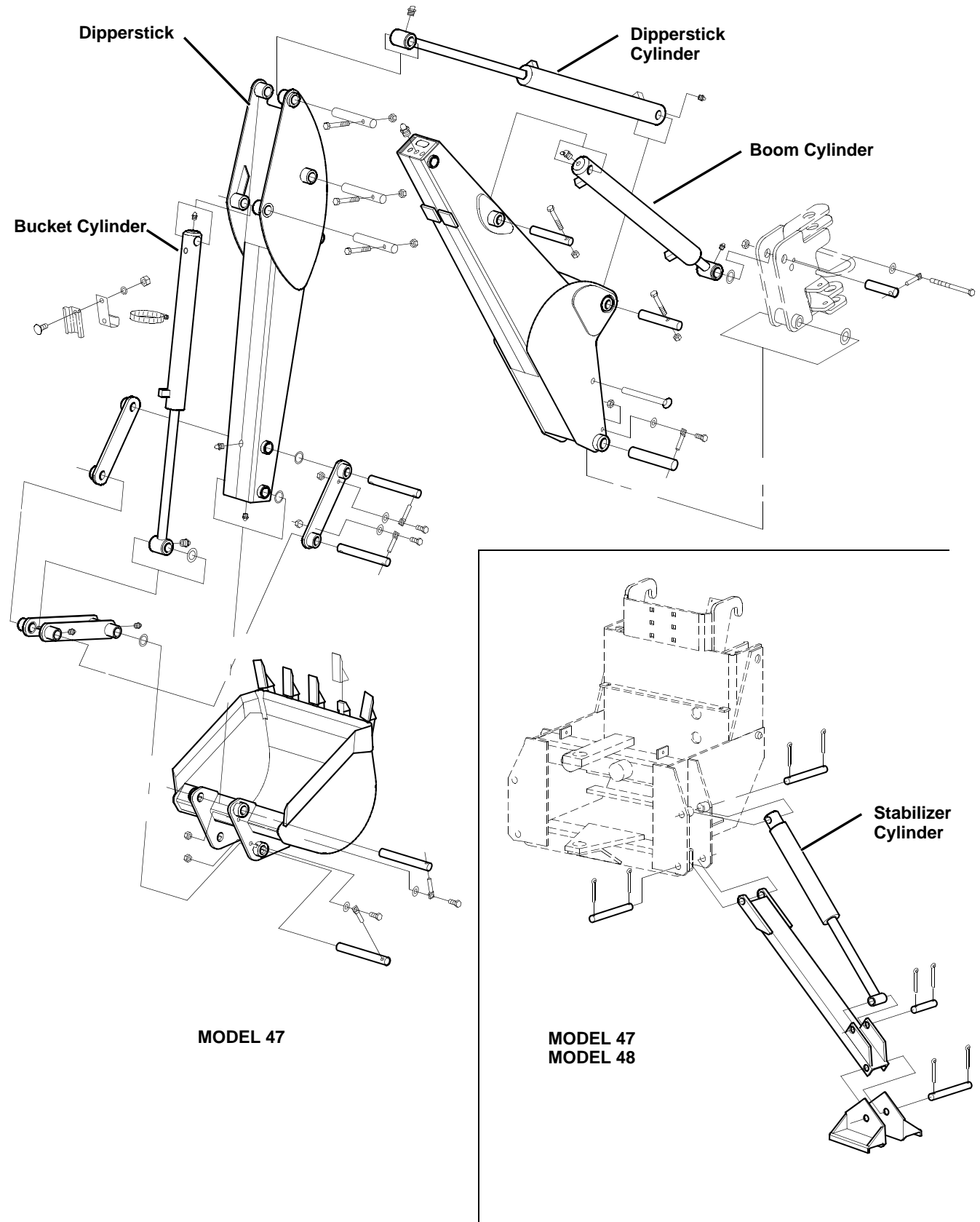

48 BOOM

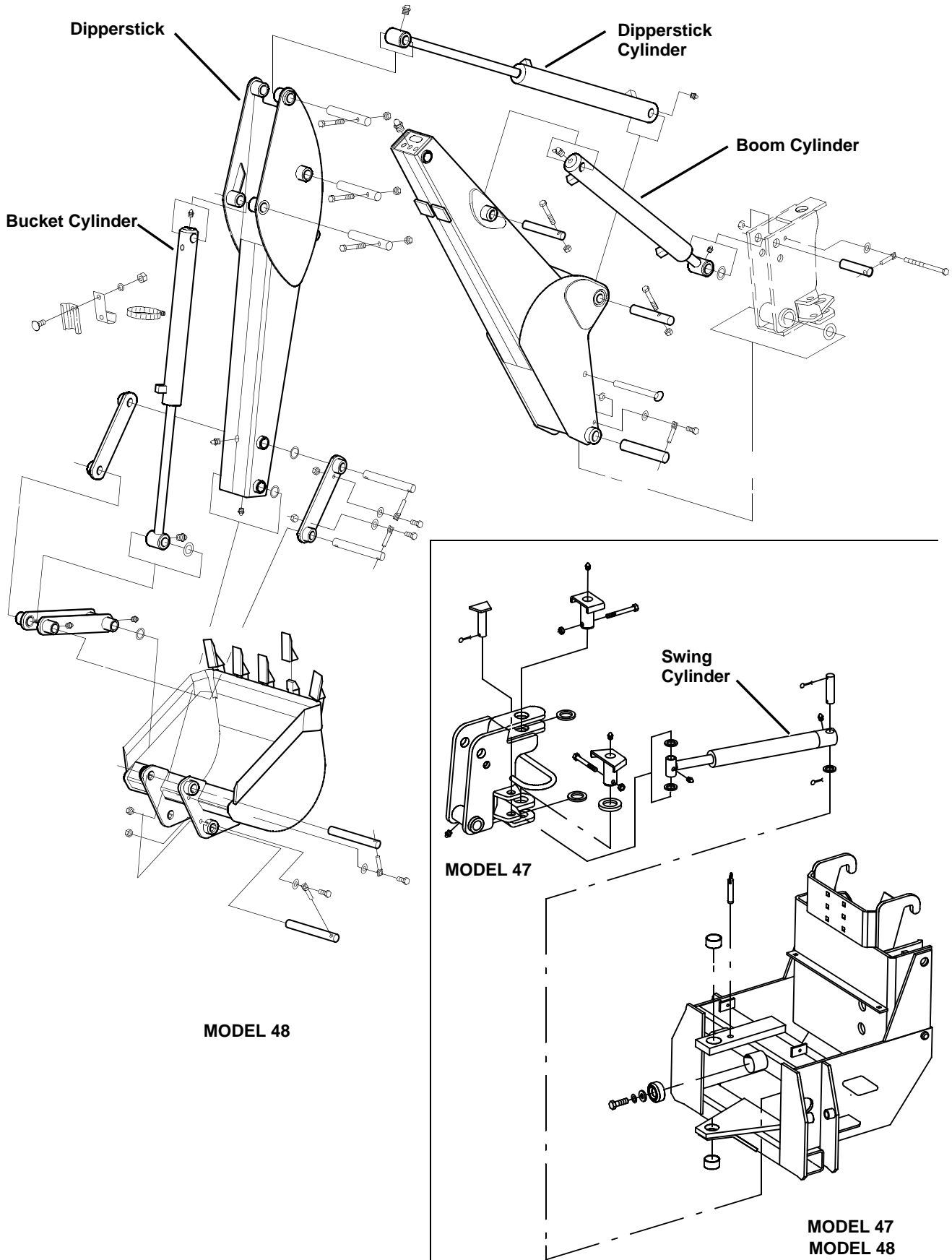

THEORY OF OPERATION

CONTROL VALVES

The hydraulic control valve consists of individual valve sections stacked side-by-side with a continuous open center for all tractors. All sections have a self centering spool that directs pressure to one of the hydraulic cylinders.

The open center systems have a main system relief valve that protects the whole backhoe hydraulic system from sharp pressure shocks. It is adjustable by adding or removing shims but should not be adjusted to a higher or lower value than recommended. In addition, two of the individual circuits are protected by circuit relief valves that are adjustable, but again, they should not be adjusted to a value that is higher or lower than recommended.

LOAD CHECK VALVES

Each valve section is equipped with load check valves. These check valves prevent reverse fluid flow if supply pressure were lost (The engine stopped running). This feature would prevent opposite direction movement of an implement should supply pressure be lost.

MAIN SYSTEM RELIEF VALVE

High pressure can be generated by continuing to operate a function after its cylinder has reached its limit. When pressure reaches system relief valve pressure, the valve opens, diverting inlet oil to the return oil passage and the rockshaft housing.

CIRCUIT RELIEF AND ANTI-CAVITATION CHECK VALVES

Circuit relief and anti-cavitation check valves are included in boom, and dipperstick valve sections.

During some operations, when the valve spool is in a neutral position, a sudden external force against the bucket will cause a pressure increase in the head end of the cylinder. To relieve that pressure and avoid damage to the valve section, the circuit relief valve opens and allows oil flow to the return oil passage.

When the circuit relief valve opens to relieve pressure in the head end of the cylinder, a void is created in the rod end (no incoming oil, valve section in neutral). Oil in the return oil passage unseats the anti-cavitation check valve ball and fills the void in the rod end.

RESTRICTORS

Restrictors are installed in both ports of the swing valve section, the IN port of the boom valve section, and the IN port of the stabilizer section.

The restrictor is a one-way orifice that acts to slow or dampen return oil flow to the valve section. This provides for smooth operation when the boom is lowered or when it is swung from side-to-side. Pressure oil flows around the restrictor and is not affected by the orifice.



BACKHOE HYDRAULIC SYSTEM

NOTE: Model 48 backhoe swing system shown.

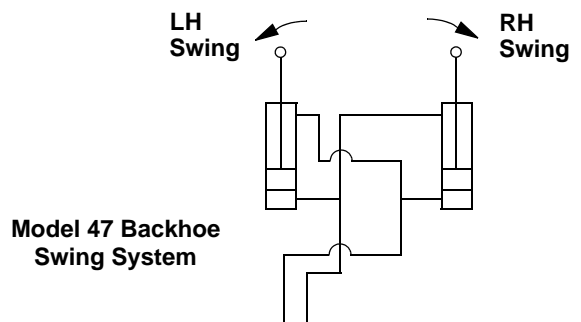
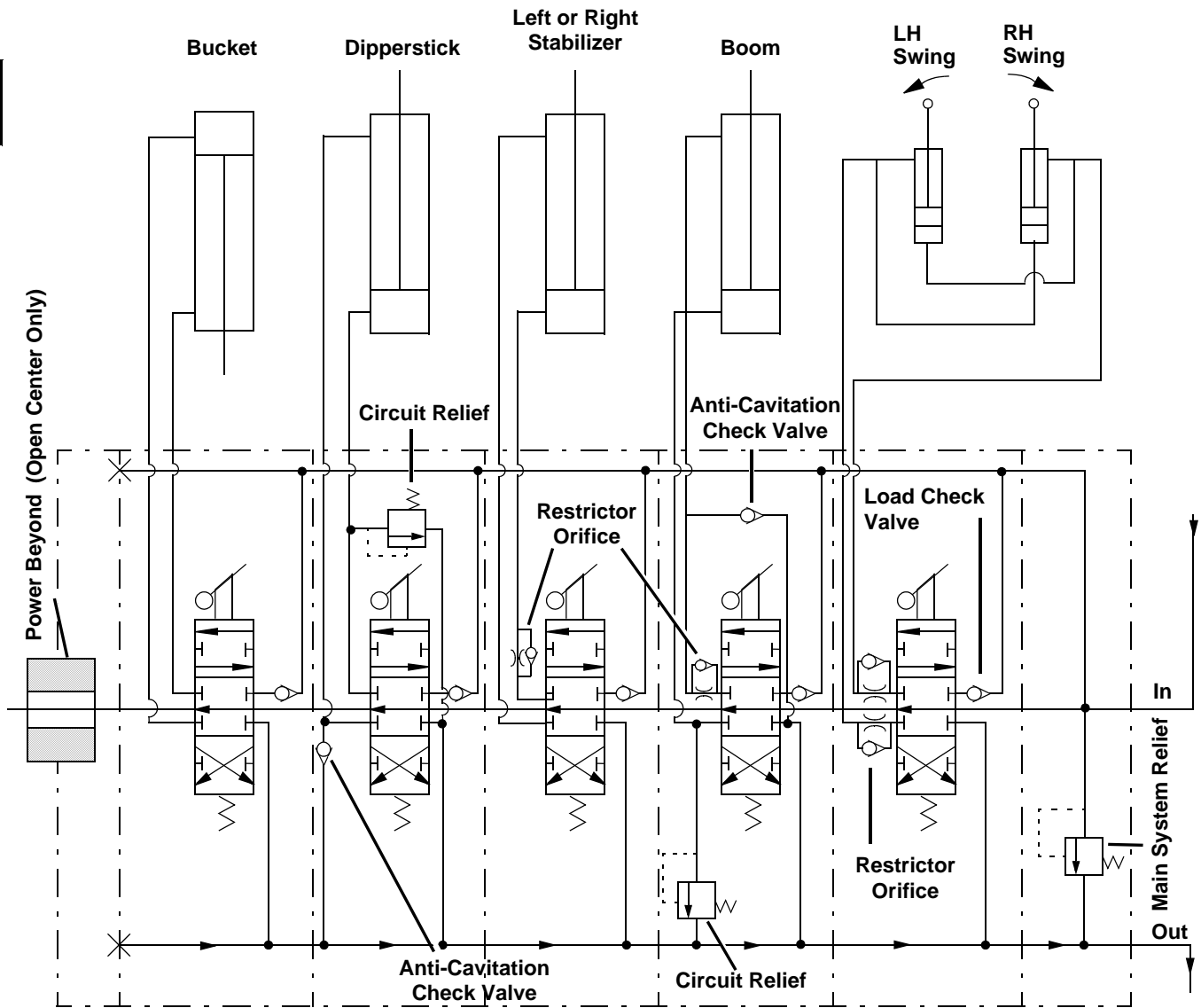

TROUBLESHOOTING

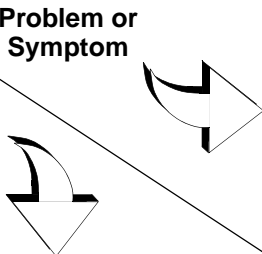
	Backhoe will not operate	Backhoe loses power	Loss of power in any one cylinder	Loss of power in boom or dipperstick only	Loss of power in swing cylinders only	Cannot obtain full swing	Slow operation	Spongy, jerking operation	Boom, dipperstick or bucket cylinders drop under load when valve is neutral
Low oil level/wrong viscosity/air in system	●	●					●	●	
No hydraulic pressure	●	●							
Improper hose connection	●	●							
Excessive back pressure, check for restriction between outlet and reservoir	●	●					●		
System relief valve malfunctioning	●	●			●		●		
Loose or leaking connectors/hoses (see Miscellaneous Sec.)		●	●		●				
Oil bypassing in cylinder		●	●		●				
Hydraulic system malfunction		●					●	●	
Pinched/restricted hydraulic hoses (see Miscellaneous Sec.)		●	●		●				
Control not positioned full open			●	●	●			●	
Load check valve leaking			●	●					●
Worn valve section		●	●		●			●	
Circuit relief valve malfunctioning		●		●					
Anti-cavitation check valve/ball stuck or not seating properly				●					●
Bent piston rod or swing linkage interference						●		●	
Engine speed too slow		●						●	
Foreign material in backhoe valve swing restrictor orifices								●	



Product: John Deere 4000 Series Compact Utility Tractor Attachments Service Repair Technical Manual

Full Download: <https://www.bobmanualstore.com/downloads/john-deere-4000-series-compact-utility-tractor-attachments-service-repair-technical-manual/>

TROUBLESHOOTING CONTINUED

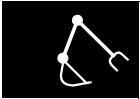

	Load drops or settles	Spool sticking, can't be pushed in or won't return to neutral	Work port leakage	Backhoe control valve leaks around spool	Boom cylinder locks up, may raise the first time	Backhoe stabilizers will not hold rear of tractor off ground	Oil leaking from differential housing vent	System is dumping pressure to relief when pushing dirt in hole
Paint on spool or scored spool	●	●						
Oil leaking passed spool into spool cap		●						
Broken return spring		●						
Bent spool		●						
Cylinder leaking	●							
Loose/leaking connectors	●							
Load check valve failure	●							
Worn valve section	●							
Hydraulic oil contaminated		●						
Misaligned control valve linkage		●						
Relief valve cartridge seals bad			●					
Spool to bore fit too tight		●						
Valve body distorted (improper mounting)		●						
Positioner assembly out of alignment due to "bumping" of positioner end		●						
Oil viscosity too heavy		●						
Spool and section seal dry (stored too long without use)		●						
Improper assembly after rebuild		●						
Excessive clearance between spool and bore of casting. Spool and casting worn due to heavy use or by contaminants introduced into spool area.	●			●				

Sample manual. Download All 150 pages at:

<https://www.bobmanualstore.com/downloads/john-deere-4000-series-compact-utility-tractor-attachments-service-repair-technical-manual/>