

Product: John Deere 1420, 1435, 1445, 1545, 1565 Front Mowers Service Repair Technical Manual

Full Download: <https://www.bobmanualstore.com/downloads/john-deere-1420-1435-1445-1545-1565-front-mowers-service-repair-technical-manual>

5-1445-15451565-front-mowers-service-repair-technical-manual

/

**JOHN DEERE**  
**WORLDWIDE COMMERCIAL & CONSUMER**  
**EQUIPMENT DIVISION**

---

**Front Mowers**  
**1420, 1435, 1445, 1545 and 1565**

TM1806 NOVEMBER 2002

**TECHNICAL MANUAL**



**JOHN DEERE**

North American Version  
Litho in U.S.A.

Sample manual. Download All 834 pages at:

<https://www.bobmanualstore.com/downloads/john-deere-1420-1435-1445-15451565-front-mowers-service-repair-technical-manual>

Product: John Deere 1420, 1435, 1445, 1545,1565 Front Mowers Service Repair Technical Manual

Full Download: <https://www.bobmanualstore.com/downloads/john-deere-1420-1435-1445-15451565-front-mowers-service-repair-technical-manual>

5-1445-15451565-front-mowers-service-repair-technical-manual

/

Sample manual. Download All 834 pages at:

<https://www.bobmanualstore.com/downloads/john-deere-1420-1435-1445-15451565-front-mowers-service-repair-technical-manual>

# INTRODUCTION

## Manual Description

This technical manual is written for an experienced technician and contains sections that are specifically for this product. It is a part of a total product support program.

The manual is organized so that all the information on a particular system is kept together. The order of grouping is as follows:

- Table of Contents
- Specifications and Information
- Identification Numbers
- Tools and Materials
- Component Location
- Schematics and Harnesses
- Theory of Operation
- Operation and Diagnostics
- Diagnostics
- Tests and Adjustments
- Repair
- Other

***NOTE: Depending on the particular section or system being covered, not all of the above groups may be used.***

The bleed tabs for the pages of each section will align with the sections listed on this page. Page numbering is consecutive from the beginning of the Safety section through the last section.

We appreciate your input on this manual. If you find any errors or want to comment on the layout of the manual please contact us.

All information, illustrations and specifications in this manual are based on the latest information at the time of publication. The right is reserved to make changes at any time without notice.

COPYRIGHT© 2002  
Deere & Co.  
John Deere Worldwide Commercial and  
Consumer Equipment Division  
All rights reserved  
Previous Editions  
COPYRIGHT©

Safety

Specifications and Information

Gas Engine

Diesel Engine (3TNE74 / 3TNE78)

Diesel Engine (3TNE88)

Electrical

Power Train - Hydro

Power Train (2 Speed) - Hydro

Steering

Brakes

Hydraulics

Attachments

Miscellaneous



# SAFETY

## Recognize Safety Information



MIF

This is the safety-alert symbol. When you see this symbol on your machine or in this manual, be alert to the potential for personal injury.

Follow recommended precautions and safe servicing practices.

## Understand Signal Words

A signal word - DANGER, WARNING, or CAUTION - is used with the safety-alert symbol. DANGER identifies the most serious hazards.

DANGER or WARNING safety signs are located near specific hazards. General precautions are listed on CAUTION safety signs. CAUTION also calls attention to safety messages in this manual.

## Replace Safety Signs

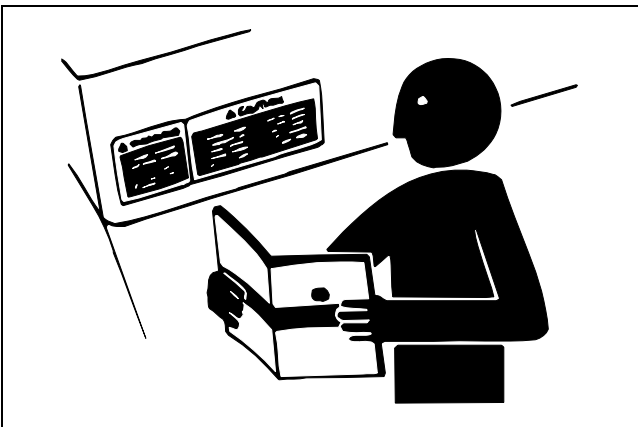

MIF

Replace missing or damaged safety signs. See the machine operator's manual for correct safety sign placement.

## Handle Fluids Safely - Avoid Fires

### Be Prepared For Emergencies

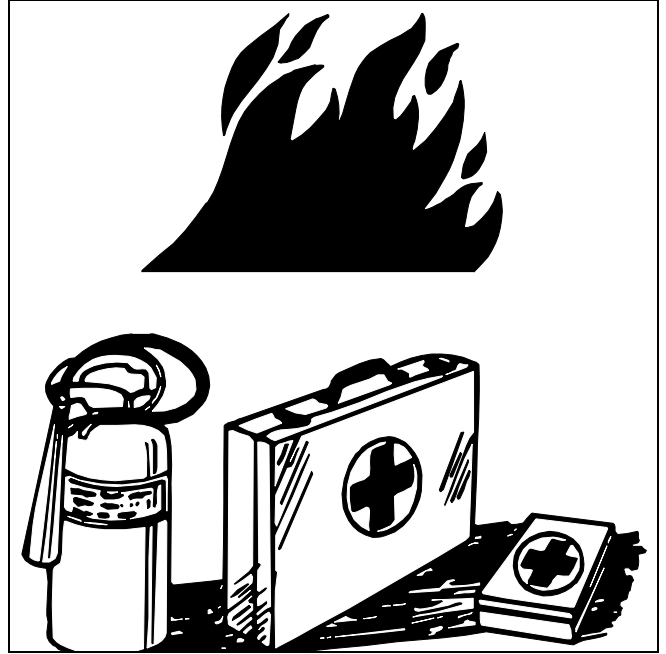

MIF

- When you work around fuel, do not smoke or work near heaters or other fire hazards.
- Store flammable fluids away from fire hazards. Do not incinerate or puncture pressurized containers.
- Make sure machine is clean of trash, grease, and debris.
- Do not store oily rags; they can ignite and burn spontaneously.
- Be prepared if a fire starts.
- Keep a first aid kit and fire extinguisher handy.
- Keep emergency numbers for doctors, ambulance service, hospital, and fire department near your telephone.

## Use Care In Handling and Servicing Batteries

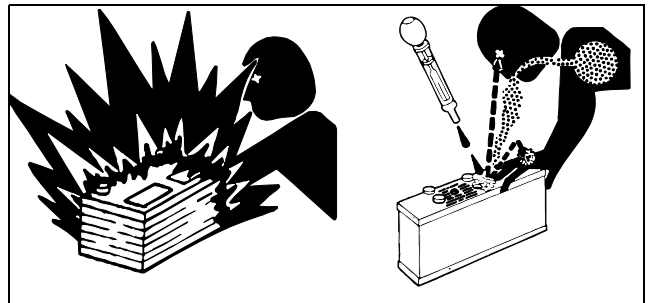

MIF

# SAFETY

## Prevent Battery Explosions

- Keep sparks, lighted matches, and open flame away from the top of battery. Battery gas can explode.
- Never check battery charge by placing a metal object across the posts. Use a volt-meter or hydrometer.
- Do not charge a frozen battery; it may explode. Warm battery to 16°C (60°F).

## Prevent Acid Burns

- Sulfuric acid in battery electrolyte is poisonous. It is strong enough to burn skin, eat holes in clothing, and cause blindness if splashed into eyes.

### Avoid acid burns by:

1. Filling batteries in a well-ventilated area.
2. Wearing eye protection and rubber gloves.
3. Avoiding breathing fumes when electrolyte is added.
4. Avoiding spilling or dripping electrolyte.
5. Use proper jump start procedure.

### If you spill acid on yourself:

1. Flush your skin with water.
2. Apply baking soda or lime to help neutralize the acid.
3. Flush your eyes with water for 10 - 15 minutes.
4. Get medical attention immediately.

### If acid is swallowed:

1. Drink large amounts of water or milk.
2. Then drink milk of magnesia, beaten eggs, or vegetable oil.
3. Get medical attention immediately.

## Wear Protective Clothing

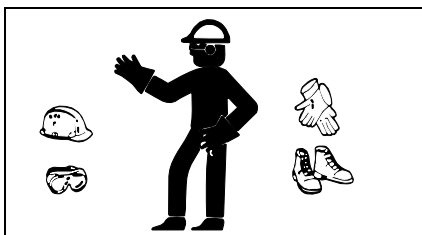

Wear close fitting clothing and safety equipment appropriate to the job.

Prolonged exposure to loud noise can cause impairment or loss of hearing. Wear a suitable hearing protective device such as earmuffs or earplugs to protect against objectionable or uncomfortable loud noises.

Operating equipment safely requires the full attention of the operator. Do not wear radio or music headphones while operating machine.

## Use Care Around High-Pressure Fluid Lines

### Avoid High-Pressure Fluids



MIF

Escaping fluid under pressure can penetrate the skin causing serious injury.

Avoid injury from escaping fluid under pressure by stopping the engine and relieving pressure in the system before disconnecting or connecting hydraulic or other lines. Tighten all connections before applying pressure.

Search for leaks with a piece of cardboard. Protect hands and body from high pressure fluids.

If an accident occurs, see a doctor immediately. Any fluid injected into the skin must be surgically removed within a few hours or gangrene may result. Doctors unfamiliar with this type of injury should reference a knowledgeable medical source. Such information is available from Deere & Company Medical Department in Moline, Illinois, U.S.A.

### Avoid Heating Near Pressurized Fluid Lines



MIF

Flammable spray can be generated by heating near pressurized fluid lines, resulting in severe burns to yourself and bystanders. Do not heat by welding, soldering, or using a torch near pressurized fluid lines or other flammable materials. Pressurized lines can be accidentally cut when heat goes beyond the immediate flame area.

# SAFETY

## Service Machines Safely

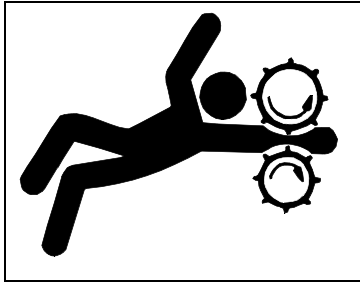

MIF

Tie long hair behind your head. Do not wear a necktie, scarf, loose clothing, or necklace when you work near machine tools or moving parts. If these items were to get caught, severe injury could result.

Remove rings and other jewelry to prevent electrical shorts and entanglement in moving parts.

## Use Proper Tools

Use tools appropriate to the work. Makeshift tools and procedures can create safety hazards. Use power tools only to loosen threaded parts and fasteners. For loosening and tightening hardware, use the correct size tools. Do not use U.S. measurement tools on metric fasteners. Avoid bodily injury caused by slipping wrenches. Use only service parts meeting John Deere specifications.

## Park Machine Safely

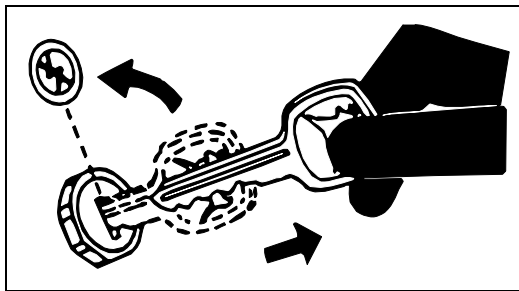

MIF

### Before working on the machine:

1. Lower all equipment to the ground.
2. Stop the engine and remove the key.
3. Disconnect the battery ground strap.
4. Hang a "Do Not Operate" tag in operator station.

## Support Machine Properly and Use Proper Lifting Equipment

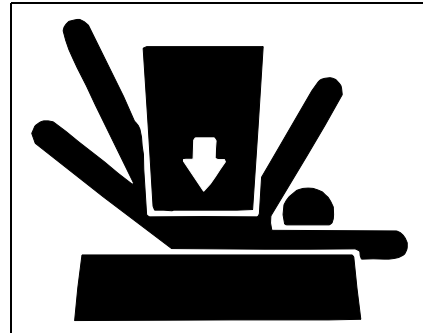

MIF

If you must work on a lifted machine or attachment, securely support the machine or attachment.

Do not support the machine on cinder blocks, hollow tiles, or props that may crumble under continuous load. Do not work under a machine that is supported solely by a jack. Follow recommended procedures in this manual.

Lifting heavy components incorrectly can cause severe injury or machine damage. Follow recommended procedure for removal and installation of components in the manual.

## Work In Clean Area

### Before starting a job:

1. Clean work area and machine.
2. Make sure you have all necessary tools to do your job.
3. Have the right parts on hand.
4. Read all instructions thoroughly; do not attempt shortcuts.

## Using High Pressure Washers

Directing pressurized water at electronic/electrical components or connectors, bearings, hydraulic seals, fuel injection pumps or other sensitive parts and components may cause product malfunctions. Reduce pressure and spray at a 45 to 90 degree angle.

## Illuminate Work Area Safely

Illuminate your work area adequately but safely. Use a portable safety light for working inside or under the machine. Make sure the bulb is enclosed by a wire cage. The hot filament of an accidentally broken bulb can ignite spilled fuel or oil.

# SAFETY

## Work In Ventilated Area

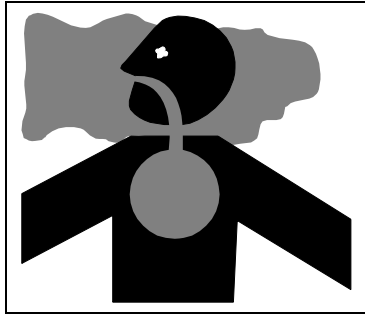

MIF

Engine exhaust fumes can cause sickness or death. If it is necessary to run an engine in an enclosed area, remove the exhaust fumes from the area with an exhaust pipe extension.

If you do not have an exhaust pipe extension, open the doors and get outside air into the area.

## Warning: California Proposition 65 Warning

Gasoline engine exhaust from this product contains chemicals known to the State of California to cause cancer, birth defects, or other reproductive harm.

Diesel engine exhaust and some of its constituents are known to the State of California to cause cancer, birth defects, and other reproductive harm.

## Remove Paint Before Welding or Heating

Avoid potentially toxic fumes and dust. Hazardous fumes can be generated when paint is heated by welding, soldering, or using a torch. Do all work outside or in a well ventilated area. Dispose of paint and solvent properly. Remove paint before welding or heating: If you sand or grind paint, avoid breathing the dust. Wear an approved respirator. If you use solvent or paint stripper, remove stripper with soap and water before welding. Remove solvent or paint stripper containers and other flammable material from area. Allow fumes to disperse at least 15 minutes before welding or heating.

## Avoid Harmful Asbestos Dust

Avoid breathing dust that may be generated when handling components containing asbestos fibers. Inhaled asbestos fibers may cause lung cancer.

Components in products that may contain asbestos fibers are brake pads, brake band and lining assemblies, clutch plates, and some gaskets. The asbestos used in these components is usually found in a resin or sealed in some way. Normal handling is not hazardous as long as airborne dust containing asbestos is not generated.

Avoid creating dust. Never use compressed air for cleaning. Avoid brushing or grinding material containing asbestos. When servicing, wear an approved respirator. A special vacuum cleaner is recommended to clean asbestos. If not available, apply a mist of oil or water on the material containing asbestos. Keep bystanders away from the area.

## Service Tires Safely



MIF

Explosive separation of a tire and rim parts can cause serious injury or death.

Do not attempt to mount a tire unless you have the proper equipment and experience to perform the job.

Always maintain the correct tire pressure. Do not inflate the tires above the recommended pressure. Never weld or heat a wheel and tire assembly. The heat can cause an increase in air pressure resulting in a tire explosion. Welding can structurally weaken or deform the wheel.

When inflating tires, use a clip-on chuck and extension hose long enough to allow you to stand to one side and not in front of or over the tire assembly. Use a safety cage if available.

Check wheels for low pressure, cuts, bubbles, damaged rims or missing lug bolts and nuts.

# SAFETY

## Avoid Injury From Rotating Blades, Augers and PTO Shafts

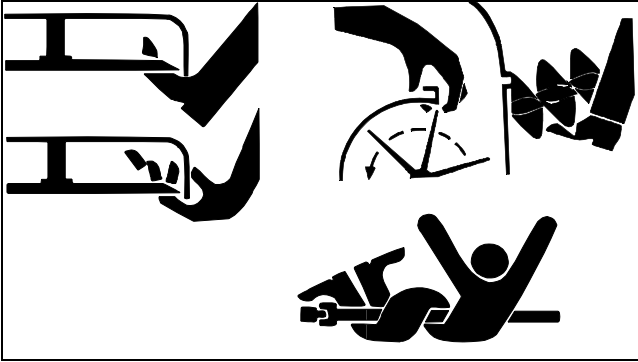

MIF

Keep hands and feet away while machine is running. Shut off power to service, lubricate or remove mower blades, augers or PTO shafts.

## Service Cooling System Safely

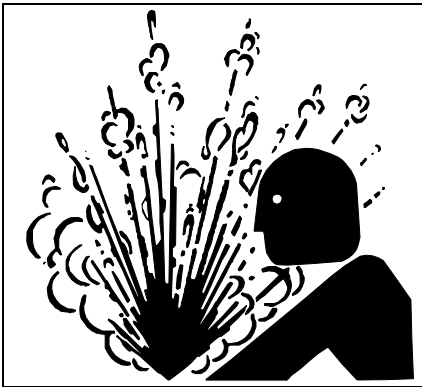

MIF

Explosive release of fluids from pressurized cooling system can cause serious burns.

Shut off machine. Only remove filler cap when cool enough to touch with bare hands. Slowly loosen cap to first stop to relieve pressure before removing completely.

## Handle Chemical Products Safely

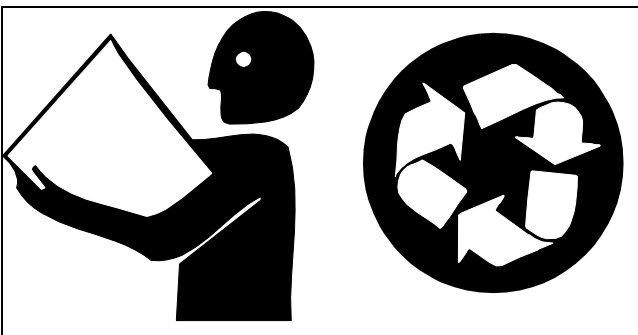

MIF

Direct exposure to hazardous chemicals can cause serious injury. Potentially hazardous chemicals used with John Deere equipment include such items as lubricants, coolants, paints, and adhesives.

A Material Safety Data Sheet (MSDS) provides specific details on chemical products: physical and health hazards, safety procedures, and emergency response techniques. Check the MSDS before you start any job using a hazardous chemical. That way you will know exactly what the risks are and how to do the job safely. Then follow procedures and recommended equipment.

## Dispose Of Waste Properly

Improperly disposing of waste can threaten the environment and ecology. Potentially harmful waste used with John Deere equipment include such items as oil, fuel, coolant, brake fluid, filters, and batteries. Use leakproof containers when draining fluids. Do not use food or beverage containers that may mislead someone into drinking from them. Do not pour waste onto the ground, down a drain, or into any water source. Inquire on the proper way to recycle or dispose of waste from your local environmental or recycling center, or from your John Deere dealer.

## Live With Safety



MIF

Before returning machine to customer, make sure machine is functioning properly, especially the safety systems. Install all guards and shields.

# SAFETY

---

---



# SPECIFICATIONS AND INFORMATION TABLE OF CONTENTS

---

## Table of Contents

<b>General Specifications .....</b>	<b>9</b>
Metric Fastener Torque Values .....	9
Metric Fastener Torque Values - Grade 7.....	10
Inch Fastener Torque Values .....	11
<b>O-Ring Seal Service Recommendations .....</b>	<b>12</b>
Face Seal Fittings with Inch Stud Ends Torque .....	12
Face Seal Fittings with Metric Stud Ends Torque .....	13
O-Ring Face Seal Fittings .....	14
O-Ring Boss Fittings .....	14
<b>Seal Tight Connector Fittings.....</b>	<b>15</b>
Service Recommendations for STC Fittings .....	15
<b>Fuel Specifications .....</b>	<b>16</b>
Gasoline Specifications .....	16
Gasoline Storage.....	17
Diesel Fuel Specifications .....	17
Diesel Fuel Lubricity .....	17
Diesel Fuel Storage.....	17
<b>Oil and Lubricant Specifications.....</b>	<b>18</b>
Engine Oil.....	18
Hydrostatic Transaxle Oil .....	18
4WD Rear Axle Oil .....	19
Anti-Corrosion Grease.....	19
Chassis Water Resistant Grease .....	20
Mower Spindle Grease.....	20
<b>Coolant Specifications .....</b>	<b>21</b>
Engine Coolant.....	21
Engine Coolant Drain Interval .....	21
<b>Serial Number Locations .....</b>	<b>22</b>
Machine Identification Number.....	22
Gasoline Engine Serial Number .....	22
Diesel Engine Serial Number .....	22
<b>Interlock System.....</b>	<b>23</b>
Interlock System.....	23

# SPECIFICATIONS AND INFORMATION TABLE OF CONTENTS

---

---



# SPECIFICATIONS AND INFORMATION GENERAL SPECIFICATIONS

## General Specifications

### Metric Fastener Torque Values

Property Class and Head Markings	4.8		8.8		9.8		10.9		12.9	
Property Class and Nut Markings	5		10		10		10		12	

SIZE	Class 4.8				Class 8.8 or 9.8				Class 10.9				Class 12.9			
	Lubricated <sup>a</sup>		Dry <sup>a</sup>		Lubricated <sup>a</sup>		Dry <sup>a</sup>		Lubricated <sup>a</sup>		Dry <sup>a</sup>		Lubricated <sup>a</sup>		Dry <sup>a</sup>	
	N•m	lb-ft	N•m	lb-ft	N•m	lb-ft	N•m	lb-ft	N•m	lb-ft	N•m	lb-ft	N•m	lb-ft	N•m	lb-ft
M6	4.8	3.5	6	4.5	9	6.5	11	8.5	13	9.5	17	12	15	11.5	19	14.5
M8	12	8.5	15	11	22	16	28	20	32	24	40	30	37	28	47	35
M10	23	17	29	21	43	32	55	40	63	47	80	60	75	55	95	70
M12	40	29	50	37	75	55	95	70	110	80	140	105	130	95	165	120
M14	63	47	80	60	120	88	150	110	175	130	225	165	205	150	260	190
M16	100	73	125	92	190	140	240	175	275	200	350	225	320	240	400	300
M18	135	100	175	125	260	195	330	250	375	275	475	350	440	325	560	410
M20	190	140	240	180	375	275	475	350	530	400	675	500	625	460	800	580
M22	260	190	330	250	510	375	650	475	725	540	925	675	850	625	1075	800
M24	330	250	425	310	650	475	825	600	925	675	1150	850	1075	800	1350	1000
M27	490	360	625	450	950	700	1200	875	1350	1000	1700	1250	1600	1150	2000	1500
M30	675	490	850	625	1300	950	1650	1200	1850	1350	2300	1700	2150	1600	2700	2000
M33	900	675	1150	850	1750	1300	2200	1650	2500	1850	3150	2350	2900	2150	3700	2750
M36	1150	850	1450	1075	2250	1650	2850	2100	3200	2350	4050	3000	3750	2750	4750	3500

- Do not use these hand torque values if a different torque value or tightening procedure is given for a specific application. Torque values listed are for general use only and include a  $\pm 10\%$  variance factor. Check tightness of fasteners periodically. Do not use air powered wrenches.
- Shear bolts are designed to fail under predetermined loads. Always replace shear bolts with identical grade.
- Fasteners should be replaced with the same class. Make sure fastener threads are clean and that you properly start thread engagement. This will prevent them from failing when tightening.
- When bolt and nut combination fasteners are used,

torque values should be applied to the nut instead of the bolt head.

- Tighten toothed or serrated-type lock nuts to the full torque value.

<sup>a</sup> A “Lubricated” means coated with a lubricant such as engine oil, or fasteners with phosphate and oil coatings. “Dry” means plain or zinc plated (yellow dichromate - Specification JDS117) without any lubrication.

Reference: JDS-200

# SPECIFICATIONS AND INFORMATION GENERAL SPECIFICATIONS

---







---

## Metric Fastener Torque Values - Grade 7

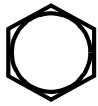
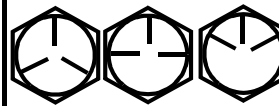
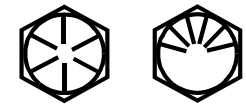
Size	Steel or Gray Iron Torque	Aluminum Torque
	N•m (lb-ft)	N•m (lb-ft)
M6	11 (8)	8 (6)
M8	24 (18)	19 (14)
M10	52 (38)	41 (30)
M12	88 (65)	70 (52)
M14	138 (102)	111 (82)
M16	224 (165)	179 (132)

# SPECIFICATIONS AND INFORMATION GENERAL SPECIFICATIONS

## Inch Fastener Torque Values

<b>SAE Grade and Head Markings</b>	1 or 2 <sup>b</sup> No Marks 	5    5.1    5.2 	8    8.2 
<b>SAE Grade and Nut Markings</b>	2 No Marks 	5  	8  

SIZE	Grade 1		Grade 2 <sup>b</sup>				Grade 5, 5.1 or 5.2				Grade 8 or 8.2					
	Lubricated <sup>a</sup>		Dry <sup>a</sup>		Lubricated <sup>a</sup>		Dry <sup>a</sup>		Lubricated <sup>a</sup>		Dry <sup>a</sup>		Lubricated <sup>a</sup>		Dry <sup>a</sup>	
	N•m	lb-ft	N•m	lb-ft	N•m	lb-ft	N•m	lb-ft	N•m	lb-ft	N•m	lb-ft	N•m	lb-ft	N•m	lb-ft
1/4	3.7	2.8	4.7	3.5	6	4.5	7.5	5.5	9.5	7	12	9	13.5	10	17	12.5
5/16	7.7	5.5	10	7	12	9	15	11	20	15	25	18	28	21	35	26
3/8	14	10	17	13	22	16	27	20	35	26	44	33	50	36	63	46
7/16	22	16	28	20	35	26	44	32	55	41	70	52	80	58	100	75
1/2	33	25	42	31	53	39	67	50	85	63	110	80	120	90	150	115
9/16	48	36	60	45	75	56	95	70	125	90	155	115	175	130	225	160
5/8	67	50	85	62	105	78	135	100	170	125	215	160	215	160	300	225
3/4	120	87	150	110	190	140	240	175	300	225	375	280	425	310	550	400
7/8	190	140	240	175	190	140	240	175	490	360	625	450	700	500	875	650
1	290	210	360	270	290	210	360	270	725	540	925	675	1050	750	1300	975
1-1/8	470	300	510	375	470	300	510	375	900	675	1150	850	1450	1075	1850	1350
1-1/4	570	425	725	530	570	425	725	530	1300	950	1650	1200	2050	1500	2600	1950
1-3/8	750	550	950	700	750	550	950	700	1700	1250	2150	1550	2700	2000	3400	2550
1-1/2	1000	725	1250	925	990	725	1250	930	2250	1650	2850	2100	3600	2650	4550	3350

- Do not use these hand torque values if a different torque value or tightening procedure is given for a specific application. Torque values listed are for general use only and include a ± 10% variance factor. Check tightness of fasteners periodically. Do not use air powered wrenches.
- Shear bolts are designed to fail under predetermined loads. Always replace shear bolts with identical grade.
- Fasteners should be replaced with the same class. Make sure fastener threads are clean and that you properly start thread engagement. This will prevent them from failing when tightening.
- When bolt and nut combination fasteners are used, torque values should be applied to the nut instead of the bolt head.

- Tighten toothed or serrated-type lock nuts to the full torque value.

<sup>a</sup> “**Lubricated**” means coated with a lubricant such as engine oil, or fasteners with phosphate and oil coatings. “**Dry**” means plain or zinc plated (yellow dichromate - Specification JDS117) without any lubrication.

<sup>b</sup> “**Grade 2**” applies for hex cap screws (not hex bolts) up to 152 mm (6 in.) long “**Grade 1**” applies for hex cap screws over 152 mm (6 in.) long, and for all other types of bolts and screws of any length.

Reference: JDS-G200

# SPECIFICATIONS AND INFORMATION O-RING SEAL SERVICE

## O-Ring Seal Service Recommendations

### Face Seal Fittings with Inch Stud Ends Torque

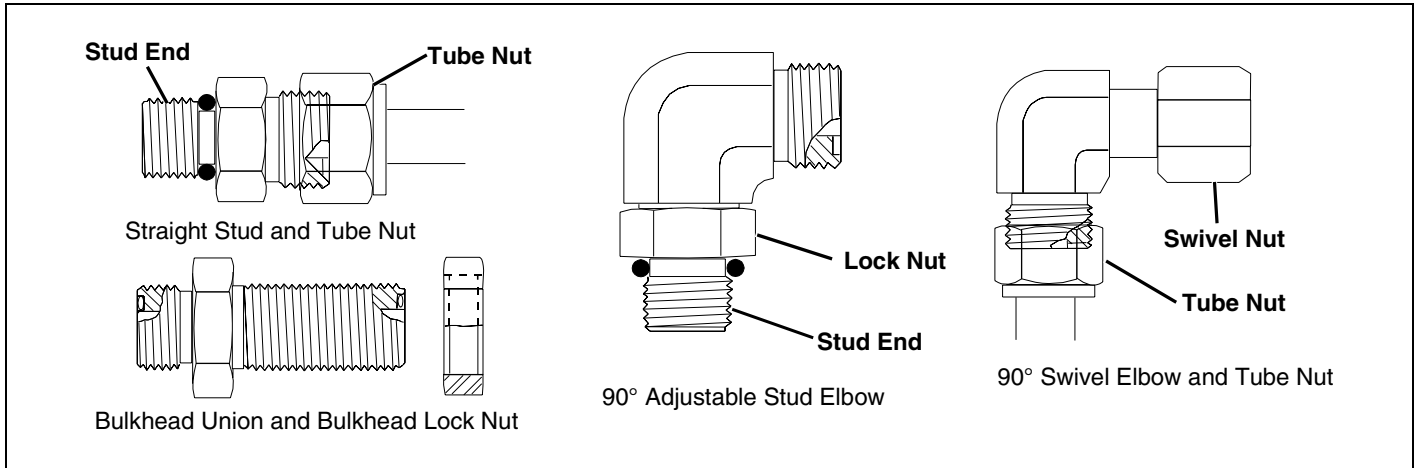

MIF

Nominal Tube OD/Hose ID				Face Seal Tube/Hose End					O-Ring Stud Ends		
Metric Tube OD	Inch Tube OD			Thread Size	Tube Nut/ Swivel Nut Torque		Bulkhead Lock Nut Torque		Thread Size	Straight Fitting or Lock Nut Torque	
mm	Dash Size	in.	mm	in.	N•m	lb-ft	N•m	lb-ft	in.	N•m	lb-ft
	-3	0.188	4.76						3/8-24	8	6
6	-4	0.250	6.35	9/16-18	16	12	12	9	7/16-20	12	9
8	-5	0.312	7.94						1/2-20	16	12
10	-6	0.375	9.52	11/16-16	24	18	24	18	9/16-18	24	18
12	-8	0.500	12.70	13/16-16	50	37	46	34	3/4-16	46	34
16	-10	0.625	15.88	1-14	69	51	62	46	7/8-14	62	46
	-12	0.750	19.05	1-3/16-12	102	75	102	75	1-1/16-12	102	75
22	-14	0.875	22.22	1-3/16-12	102	75	102	75	1-3/16-12	122	90
25	-16	1.000	25.40	1-7/16-12	142	105	142	105	1-5/16-12	142	105
32	-20	1.25	31.75	1-11/16-12	190	140	190	140	1-5/8-12	190	140
38	-24	1.50	38.10	2-12	217	160	217	160	1-7/8-12	217	160

**NOTE: Torque tolerance is +15%, -20%**

# SPECIFICATIONS AND INFORMATION O-RING SEAL SERVICE

## Face Seal Fittings with Metric Stud Ends Torque

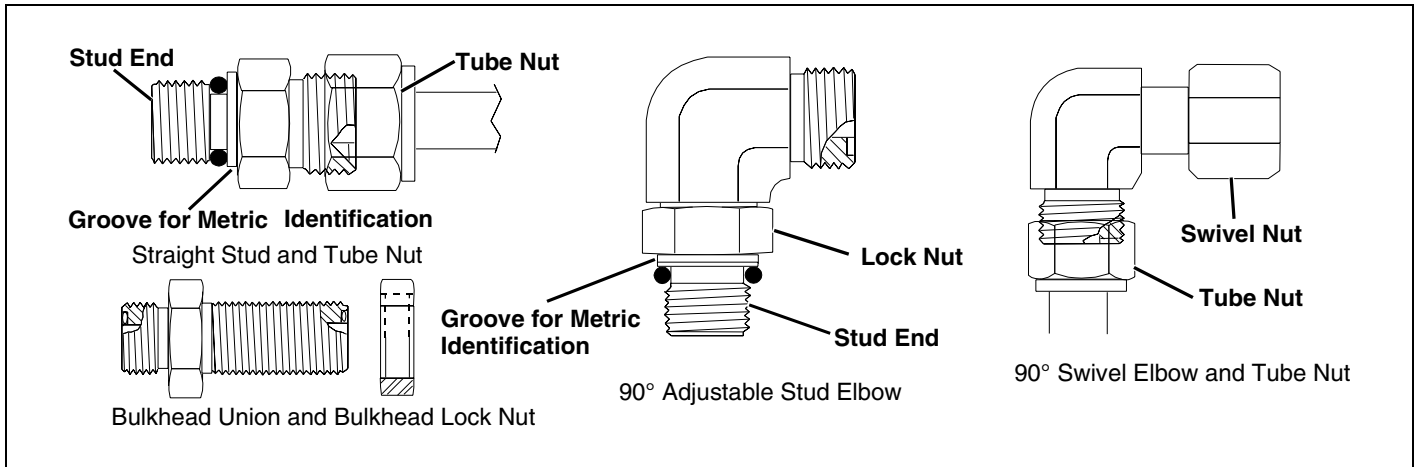

MIF

Nominal Tube OD/Hose ID				Face Seal Tube/Hose End						O-Ring Stud Ends, Straight Fitting or Lock Nut					
Metric Tube OD	Inch Tube OD			Thread Size	Hex Size	Tube Nut/ Swivel Nut Torque		Bulkhead Lock Nut Torque		Thread Size	Hex Size	Steel or Gray Iron Torque		Aluminum Torque	
	mm	Das h Size	in.			mm	in.	mm	N•m			lb-ft	N•m	lb-ft	mm
6	-4	0.250	6.35	9/16-18	17	16	12	12	9	M12X1.5	17	21	15.5	9	6.6
8	-5	0.312	7.94												
										M14X1.5	19	33	24	15	11
10	-6	0.375	9.52	11/16-16	22	24	18	24	18	M16X1.5	22	41	30	18	13
12	-8	0.500	12.70	13/16-16	24	50	37	46	34	M18X1.5	24	50	37	21	15
16	-10	0.625	15.88	1-14	30	69	51	62	46	M22X1.5	27	69	51	28	21
	-12	0.750	19.05	1-3/16-12	36	102	75	102	75	M27X2	32	102	75	46	34
22	-14	0.875	22.22	1-3/16-12	36	102	75	102	75	M30X2	36				
25	-16	1.000	25.40	1-7/16-12	41	142	105	142	105	M33X2	41	158	116	71	52
28										M38X2	46	176	130	79	58
32	-20	1.25	31.75	1-11/16-12	50	190	140	190	140	M42X2	50	190	140	85	63
38	-24	1.50	38.10	2-12	60	217	160	217	160	M48X2	55	217	160	98	72

**NOTE: Torque tolerance is +15%, -20%**

# SPECIFICATIONS AND INFORMATION O-RING SEAL SERVICE

## O-Ring Face Seal Fittings

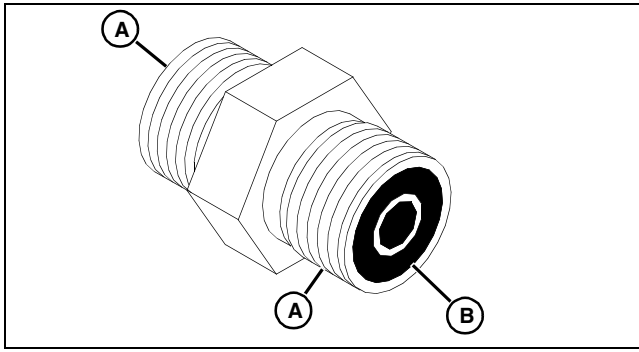

1. Inspect the fitting sealing surfaces (A). They must be free of dirt or defects.
2. Inspect the O-ring (B). It must be free of damage or defects.
3. Lubricate O-rings and install into groove using petroleum jelly to hold in place.
4. Push O-ring into the groove with plenty of petroleum jelly so O-ring is not displaced during assembly.
5. Index angle fittings and tighten by hand-pressing joint together to ensure O-ring remains in place.

**IMPORTANT: Avoid damage! Do not allow hoses to twist when tightening fittings. Use two wrenches to tighten hose connections; one to hold the hose, and the other to tighten the swivel fitting.**

6. Tighten fitting or nut to torque value shown on the chart per dash size stamped on the fitting.

## O-Ring Boss Fittings

1. Inspect boss O-ring boss seat. It must be free of dirt and defects. If repeated leaks occur, inspect for defects with a magnifying glass. Some raised defects can be removed with a slip stone.

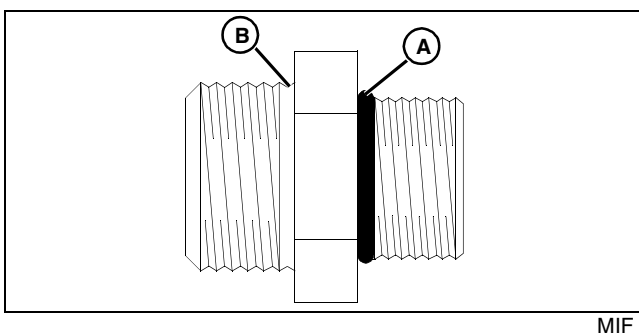

2. Put hydraulic oil or petroleum jelly on the O-ring (A). Place electrical tape over the threads to protect O-ring from nicks. Slide O-ring over the tape and into the groove (B) of fitting. Remove tape.

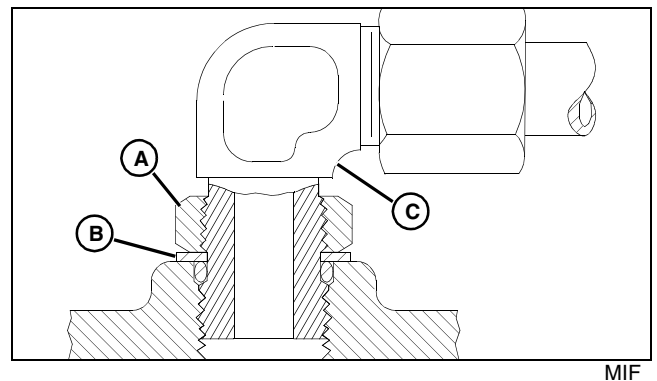

3. For angle fittings, loosen special nut (A) and push special washer (B) against threads so O-ring can be installed into the groove of fitting.
4. Turn fitting into the boss by hand until special washer or washer face (straight fitting) contacts boss face and O-ring is squeezed into its seat.
5. To position angle fittings (C), turn the fitting counterclockwise a maximum of one turn.
6. Tighten straight fittings to torque value shown on chart. For angle fittings, tighten the special nut to value shown in the chart while holding body of fitting with a wrench.

Thread Size	Torque <sup>a</sup>		Number of Flats <sup>b</sup>
	N•m	lb-ft	
3/8-24 UNF	8	6	2
7/16-20 UNF	12	9	2
1/2-20 UNF	16	12	2
9/16-18 UNF	24	18	2
3/4-16 UNF	46	34	2
7/8-14 UNF	62	46	1-1/2
1-1/16-12 UN	102	75	1
1-3/16-12 UN	122	90	1
1-5/16-12 UN	142	105	3/4
1-5/8-12 UN	190	140	3/4
1-7/8-12 UN	217	160	1/2

<sup>a</sup>Torque tolerance is  $\pm 10$  percent.

<sup>b</sup>To be used if a torque wrench cannot be used. After tightening fitting by hand, put a mark on nut or boss; then tighten special nut or straight fitting the number of flats shown.

# SPECIFICATIONS AND INFORMATION SEAL TIGHT CONNECTOR

## Seal Tight Connector Fittings

### Service Recommendations for STC Fittings

#### Special or Required Tools:

Tool Name	Tool No.	Tool Use
Hose Removal Tool	JDG1386	Used to remove hoses.

#### Seal Tight Connector (STC)® Fittings:

STC fittings are used on this machine. The fittings are designed for quick leak-proof connections.

Compact swivel-type connections can be made easily. Fittings are available in -06, -08, -10, -12, and -16 sizes.

Fittings are easily disconnected using hose removal tool JDG1386. To connect fittings, simply push each half of fitting together.

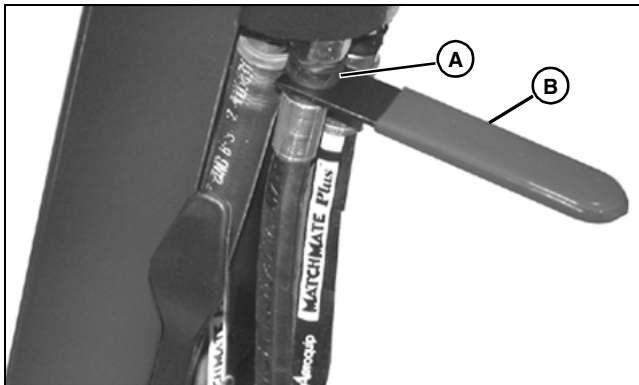

MX5540

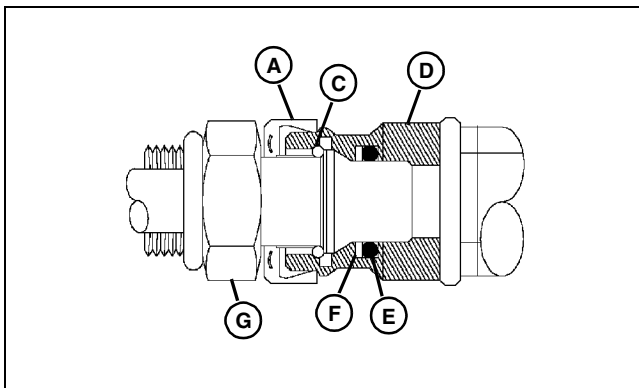

MX5695

- A - Release Sleeve
- B - Hose Removal Tool
- C - Retaining Ring
- D - Female Half of STC Fitting
- E - O-Ring
- F - Backup Ring
- G - Male Half of STC Fitting

**IMPORTANT: Avoid damage! Do not pry against release sleeve (1) or damage to fitting may result.**

**Do not force release sleeve beyond normal range of travel, or release sleeve may fall off when hose is disconnected. If this happens and fitting is connected without the release sleeve installed, fitting will not be able to be disconnected again.**

1. Disconnect STC-type fittings:
  - a. Clean area around fitting, especially around the release sleeve (A).
  - b. While keeping hose removal tool JDG1386 (B) perpendicular to the fitting, insert tool under release sleeve until tool stops.
  - c. Pull hose away from fitting to disconnect.
2. Inspect STC fittings:
  - a. Check seal mating surfaces for nicks, scratches, or flat spots.
  - b. Check O-ring (E), backup ring (F), and retaining ring (3) for wear or damage. Replace if damaged or if fittings look good but connection leaks.
  - c. O-ring, backup ring, and retaining ring must be in position before connecting fitting halves. Install backup ring first, then the O-ring behind the backup ring.
3. Connect STC fittings:
  - a. Make sure fitting halves are clean and free of contaminants.

**IMPORTANT: Avoid damage! If release sleeve is not on fitting when connection is made, fitting will not be able to be disconnected.**

- b. Make sure release sleeve (A) is on male half of fitting before connecting fitting halves together.
- c. Push fitting halves together until definite, solid stop is felt.
- d. Pull back on hose to make sure fitting halves are locked together.
- e. To prevent hoses from binding, move component into position before pressurizing hydraulic system.

# SPECIFICATIONS AND INFORMATION FUEL SPECIFICATIONS

## Fuel Specifications

### Gasoline Specifications

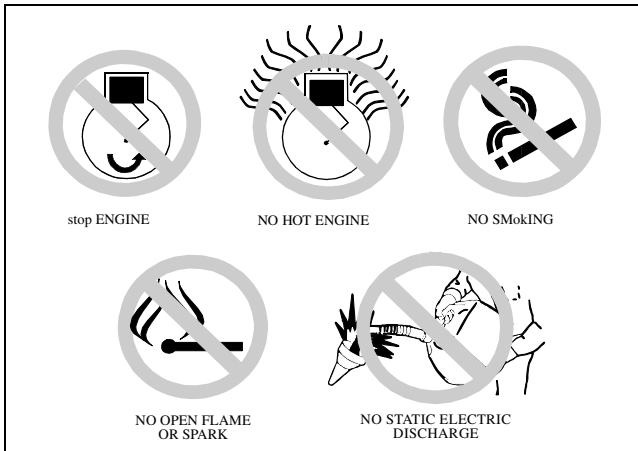

MIF



**CAUTION: Avoid injury! Gasoline is highly flammable, handle it with care.**

**Do not refuel machine while:**

- indoors, always fill gas tank outdoors;
- machine is near an open flame or sparks;
- engine is running, stop engine;
- engine is hot, allow it to cool sufficiently first;
- smoking.

**Help prevent fires:**

- fill gas tank to bottom of filler neck only;
- be sure fill cap is tight after fueling;
- clean up any gas spills immediately;
- keep machine clean and in good repair - free of excess grease, oil, debris, and faulty or damaged parts;
- any storage of machines with gas left in tank should be in an area that is well ventilated to prevent possible igniting of fumes by an open flame or spark, this includes any appliance with a pilot light.

**To prevent fire or explosion caused by static electric discharge during fueling:**

- Only use a clean, approved polyethylene plastic fuel container and funnel without any metal screen or filter.



**CAUTION: Avoid injury! California Proposition 65 Warning: Gasoline engine exhaust from this product contains chemicals known to the State of California to cause cancer, birth defects, or other reproductive harm.**

**To Avoid Engine Damage:**

- Do not mix oil with gasoline;
- **Only use clean, fresh unleaded gasoline with an octane rating (anti-knock index) of 87 or higher;**
- fill gas tank at the end of each day's operation to help prevent condensation from forming inside a partially filled tank;
- keep up with specified service intervals.

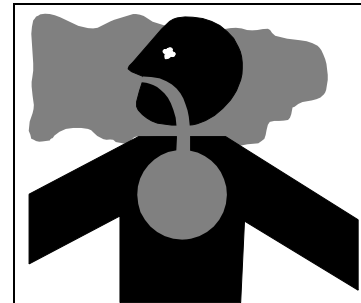

MIF



**CAUTION: Avoid injury! Do not use METHANOL gasoline because METHANOL is harmful to the environment and to your health**

Use of alternative oxygenated, gasohol blended, unleaded gasoline is acceptable as long as:

- the ethyl or grain alcohol blends Do not exceed 10% by volume or
- methyl tertiary butyl ether (MTBE) blends Do not exceed 15% by volume.

# SPECIFICATIONS AND INFORMATION FUEL SPECIFICATIONS

## Gasoline Storage

**IMPORTANT: Avoid damage! Keep all dirt, scale, water or other foreign material out of gasoline.**

Keep gasoline stored in a safe, protected area. Storage of gasoline in a clean, properly marked (“**UNLEADED GASOLINE**”) **polyethylene plastic container** without any metal screen or filter is recommended. **Do not** use de-icers to attempt to remove water from gasoline or depend on fuel filters to remove water from gasoline. Use a water separator installed in the storage tank outlet. **Be sure** to properly discard unstable or contaminated gasoline. When storing machine or gasoline, it is recommended that you add **John Deere Gasoline Conditioner and Stabilizer (TY15977)** or an equivalent to the gasoline. **Be sure** to follow directions on container and to properly discard empty container.

## Diesel Fuel Specifications



**CAUTION: Avoid injury! California Proposition 65 Warning: Gasoline engine exhaust from this product contains chemicals known to the State of California to cause cancer, birth defects, or other reproductive harm.**

In general, diesel fuels are blended to satisfy the low air temperature requirements of the geographical area in which they are sold.

In North America, diesel fuel is usually specified to **ASTM D975** and sold as either **Grade 1** for cold air temperatures or **Grade 2** for warm air temperatures.

If diesel fuels being supplied in your area Do not meet any of the above specifications, use diesel fuels with the following equivalent properties:

- **Cetane Number 40 (minimum)**

A cetane number **greater than 50 is preferred**, especially for air temperatures below  $-20^{\circ}\text{C}$  ( $-4^{\circ}\text{F}$ ) or elevations above 1500 m (5000 ft).

- **Cold Filter Plugging Point (CFPP)**

The air temperature at which diesel fuel **begins to cloud or jell** - at least  $5^{\circ}\text{C}$  ( $9^{\circ}\text{F}$ ) below the expected low air temperature range.

- **Sulfur Content of 0.05% (maximum)**

Diesel fuels for highway use in the United States now require sulfur content to be **less than 0.05%**.

If diesel fuel being used has a sulfur content **greater than 0.05%**, **reduce the service interval for engine oil and filter by 50%**.

Consult your local diesel fuel distributor for properties of the diesel fuel available in your area.

## Diesel Fuel Lubricity

Diesel fuel must have adequate lubricity to ensure proper operation and durability of fuel injection system components. Fuel lubricity should pass a **minimum of 3300 gram load level** as measured by the **BOCLE** scuffing test.

## Diesel Fuel Storage

**IMPORTANT: Avoid damage! Do not use galvanized containers - diesel fuel stored in galvanized containers reacts with zinc coating in the container to form zinc flakes. If fuel contains water, a zinc gel will also form. The gel and flakes will quickly plug fuel filters and damage fuel injectors and fuel pumps.**

It is recommended that diesel fuel be stored **only** in a clean, approved **polyethylene plastic** container **without** any metal screen or filter. This will help prevent any accidental sparks from occurring. Store fuel in an area that is well ventilated to prevent possible igniting of fumes by an open flame or spark, this includes any appliance with a pilot light.

**IMPORTANT: Avoid damage! Keep all dirt, scale, water or other foreign material out of fuel.**

Keep fuel in a safe, protected area and in a clean, properly marked (“**DIESEL FUEL**”) container. **Do not** use de-icers to attempt to remove water from fuel. **Do not** depend on fuel filters to remove water from fuel. It is recommended that a water separator be installed in the storage tank outlet. **Be sure** to properly discard unstable or contaminated diesel fuel and/or their containers when necessary.

# SPECIFICATIONS AND INFORMATION OIL AND LUBRICANT

## Oil and Lubricant Specifications

### Engine Oil

Use oil viscosity based on the expected air temperature range during the period between oil changes.

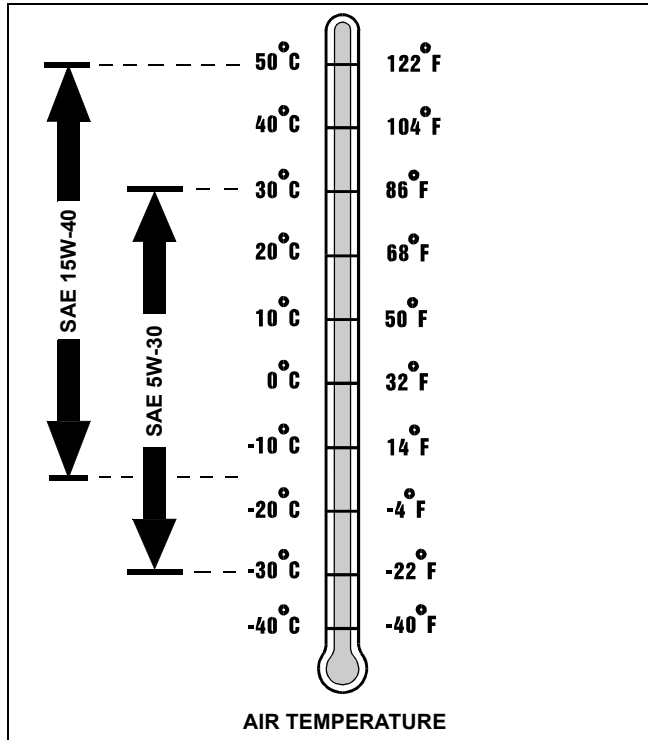

MIF

### The Following John Deere Oils are preferred:

#### Diesel Engines

- TORQ-GARD SUPREME®
- PLUS-4®
- PLUS-50®

Other oils may be used if above John Deere oils are not available, provided they meet the following specifications:

- API Service Classification CF or higher.

#### Gasoline Engines

- TURF-GARD®
- PLUS-4®

Other oils may be used if above John Deere oils are not available, provided they meet the following specifications:

- API Service Classification SG or higher.

## Hydrostatic Transaxle Oil

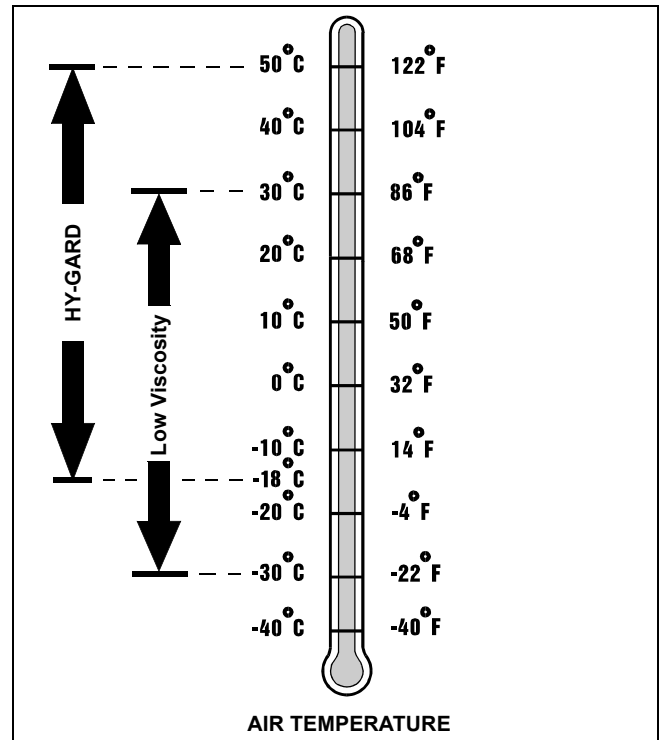

MIF

**IMPORTANT: Avoid damage! Transaxle is filled with John Deere HY-GARD® (J20C) transmission oil at the factory. Do not mix oils**

Use only HY-Gard® (J20C) transmission.

Do not use type "F" automatic transmission fluid.

John Deere HY-GARD (J20C) transmission oil is specially formulated to provide maximum protection against mechanical wear, corrosion, and foaming.

**IMPORTANT: Avoid damage! If operating temperatures are below -18°C (0°F), you must use Low Viscosity HY-GARD® (J20D) or transmission damage will occur.**

# SPECIFICATIONS AND INFORMATION OIL AND LUBRICANT

## 4WD Rear Axle Oil

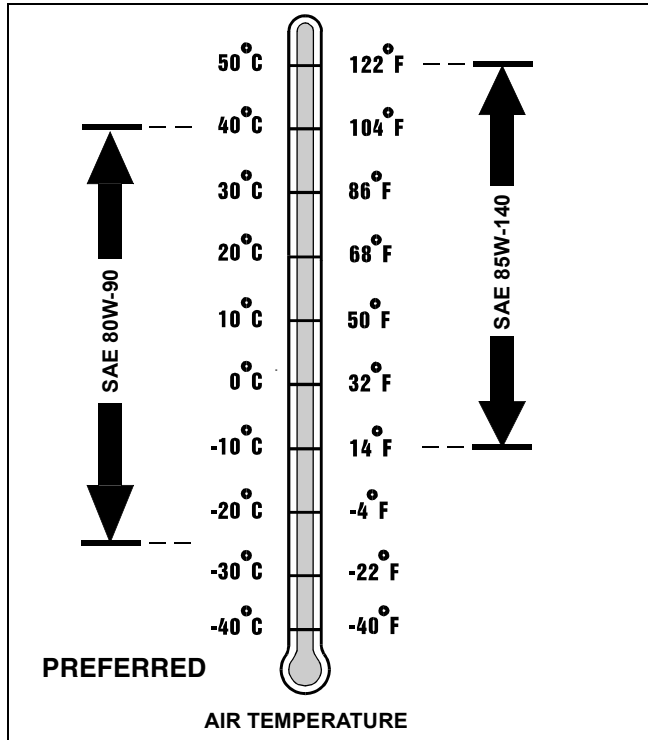

MIF

Use the appropriate oil viscosity based on the air temperature ranges. Operating outside of these recommended oil air temperature ranges may cause premature gear case failure.

**IMPORTANT: Avoid damage! Only use a quality oil in this gear case. Do not mix any other oils in this gear case. Do not use BIO-HY-GARD® in this gear case.**

The following John Deere gear case oil is **preferred**:

- GL-G GEAR LUBRICANT® - SAE 80W-90.

The following John Deere gear case oil is **also recommended** if above preferred oil is not available:

- GL-5 GEAR LUBRICANT® - SAE 85W-140

Other gear case oils may be used if above recommended John Deere gear case oils are not available, provided they meet the following specification:

- API Service Classification GL-5.

## Anti-Corrosion Grease

This anti-corrosion grease is formulated to provide the best protection against absorbing moisture, which is one of the major causes of corrosion. This grease is also superior in its resistance to separation and migration.

The following anti-corrosion grease is **preferred**:

- DuBois MPG-2® Multi-Purpose Polymer Grease - M79292.

Other greases may be used if they meet or exceed the following specification:

- John Deere Standard JDM J13A2, NLGI Grade 1.

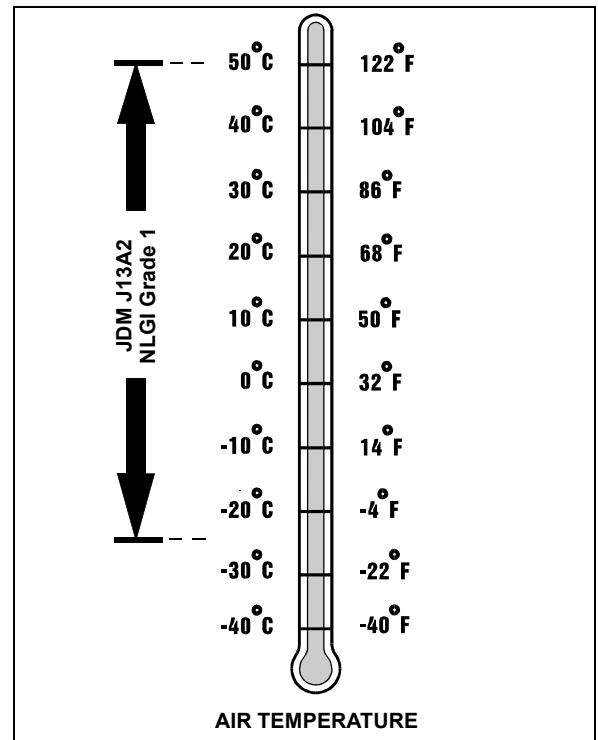

MIF

# SPECIFICATIONS AND INFORMATION OIL AND LUBRICANT

## Chassis Water Resistant Grease

This grease is specially formulated to prevent corrosion and water washout when used in a wet environment.

The following water resistant grease is **preferred**:

- Special Purpose HD Water Resistant Grease - TY24425.

The following water resistant grease may also be used:

- Multi-Purpose HD Lithium Complex Grease - TY24416.

Other greases may be used if they meet or exceed the following specification:

- John Deere Standard JDM J13E4, NLGI Grade 2.

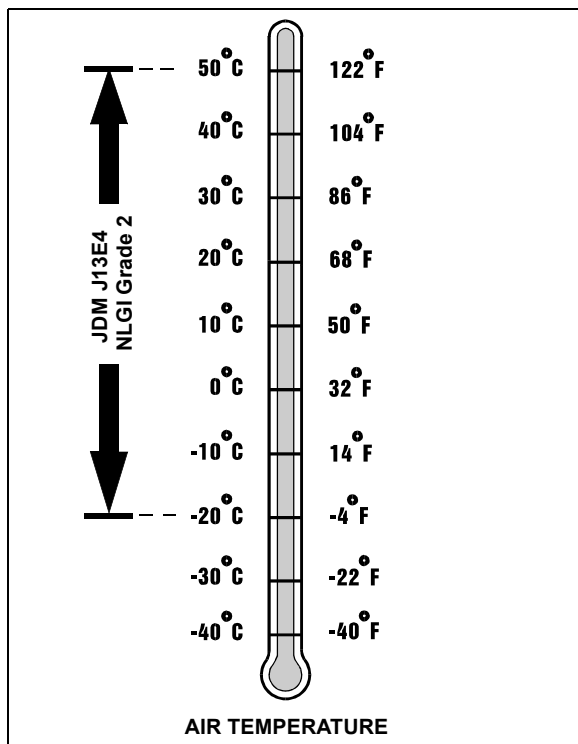

MIF

## Mower Spindle Grease

This premium, multi-purpose grease is specially formulated as a high-temperature, extreme-pressure grease, especially effective in rolling contact applications.

The following water resistant grease is **preferred**:

- Multi-Purpose SD Polyurea Grease - TY6341.

The following multi-purpose grease may also be used:

- Multi-Purpose HD Lithium Complex Grease - TY24416.

Other greases may be used if they meet or exceed the following specification:

- John Deere Standard JDM J13E4, NLGI Grade 2.

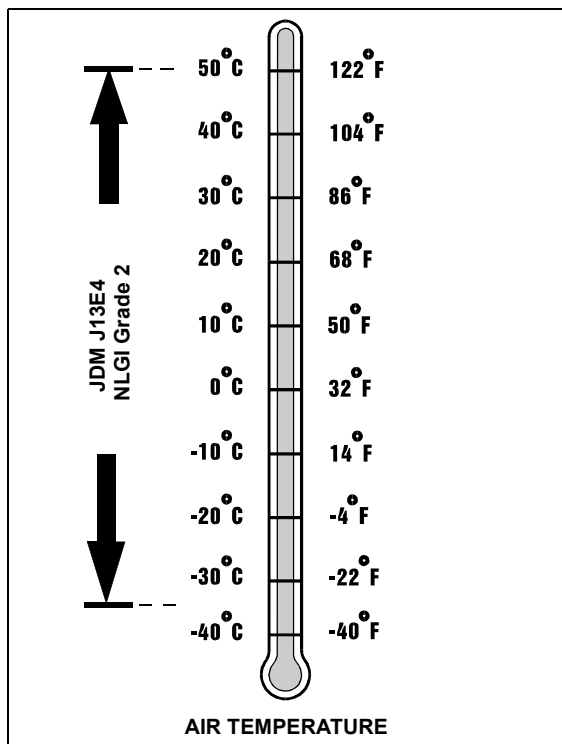

MIF

# SPECIFICATIONS AND INFORMATION COOLANT SPECIFICATIONS

## Coolant Specifications

### Engine Coolant

The engine cooling system, when filled with a proper dilution mixture of anti-freeze and deionized or distilled water, provides year-round protection against corrosion, cylinder or liner pitting, and winter freeze protection down to -37°C (-34°F).

The following John Deere coolant is **preferred**:

- PRE-DILUTED DIESEL ENGINE ANTI-FREEZE/SUMMER COOLANT™ (TY16036).

This coolant satisfies specifications for “Automobile and Light Duty Engine Service” and is safe for use in John Deere Lawn and Grounds Care/Golf and Turf Division equipment, including aluminum block gasoline engines and cooling systems.

The above preferred pre-diluted anti-freeze provides:

- adequate heat transfer
- corrosion-resistant chemicals for the cooling system
- compatibility with cooling system hose and seal material
- protection during extreme cold and extreme hot weather operations
- chemically pure water for better service life
- compliance with ASTM D4656 (JDM H24C2) specifications

If above preferred pre-diluted coolant is not available, the following John Deere concentrate is **recommended**:

- DIESEL ENGINE ANTI-FREEZE/SUMMER COOLANT ConCENTRATE™ (TY16034).

If either of above recommended engine coolants are not available use any Automobile and Light Duty Engine Service **ethylene glycol base coolant**, meeting the following specification:

- ASTM D3306 (JDM H24C1).

Read container label completely before using and follow instructions as stated.

**IMPORTANT: Avoid damage! To prevent engine damage, do not use pure anti-freeze or less than a 50% anti-freeze mixture in the cooling system. Do not mix or add any additives/conditioners to the cooling system in Lawn and Grounds Care/Golf and Turf Division equipment. Water used to dilute engine coolant concentrate must be of high quality - clean, clear, potable water (low in chloride and hardness - Table 1) is generally acceptable. Do not use salt water. Deionized or distilled water is ideal to use. Coolant that is not mixed to these specified levels and water purity can cause excessive scale, sludge deposits, and increased corrosion potential.**

Property	Requirements
Total Solids, Maximum	340 ppm (20 grns/gal)
Total Hardness, Maximum	170 ppm (10 grns/gal)
Chloride (as Cl), Maximum	40 ppm (2.5 grns/gal)
Sulfate (as SO <sub>4</sub> ), Maximum	100 ppm (5.8 grns/gal)

Mix 50 percent anti-freeze concentrate with 50 percent distilled or deionized water. This mixture and the pre-diluted mixture (TY16036) will protect the cooling system down to -37°C (-34°F) and up to 108°C (226°F).

Certain geographical areas may require lower air temperature protection. See the label on your anti-freeze container or consult your John Deere dealer to obtain the latest information and recommendations.

### Engine Coolant Drain Interval

When using **John Deere Pre-Diluted (TY16036)** Automobile and Light Duty Engine Service coolants, drain and flush the cooling system and refill with fresh coolant mixture every **36 months or 3,000 hours** of operation, whichever comes first.

When using **John Deere Concentrate (TY16034)** Automobile and Light Duty Engine Service coolants, drain and flush the cooling system and refill with fresh coolant mixture every **24 months or 2,000 hours** of operation, whichever comes first.

If above John Deere Automobile and Light Duty Engine Service coolants **are not** being used, drain, flush, and refill the cooling system according to instructions found on product container or in equipment operator’s manual or technical manual.

# SPECIFICATIONS AND INFORMATION SERIAL NUMBER LOCATIONS

## Serial Number Locations

### Machine Identification Number

### Product Identification Number

### Front Mower:



MX7053

The machine identification number is located on the rear frame plate.

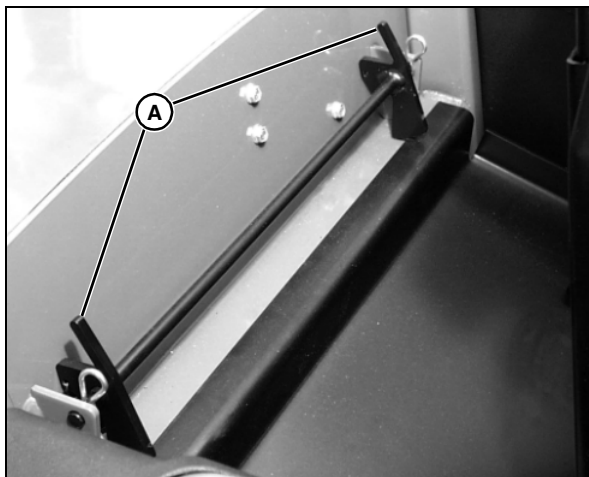

MX4482

To access the engine serial number plate, raise the operator's seat platform, pull forward on release lever (A), while pulling forward on the backrest of operator's seat.

## Gasoline Engine Serial Number

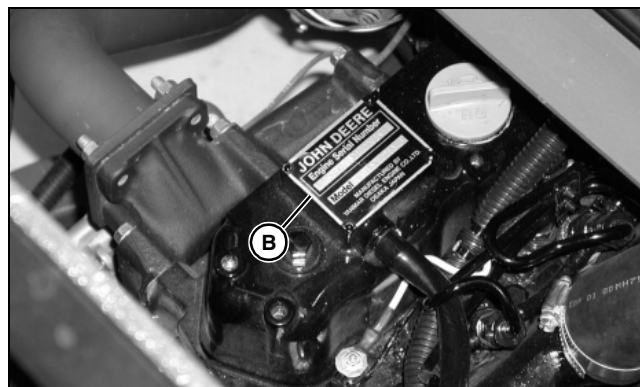

MX7086

The gasoline engine serial number plate (B) is located on top of the valve cover near the engine oil filler cap.

## Diesel Engine Serial Number

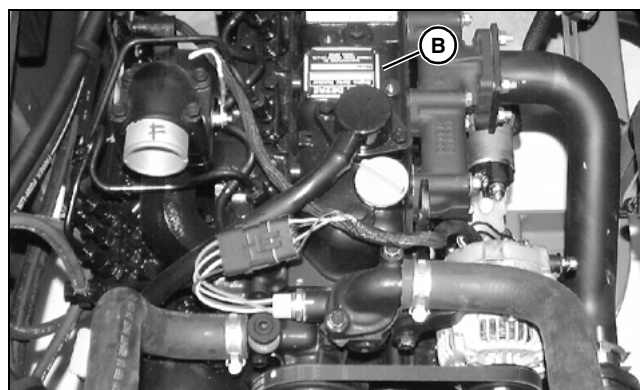

MX5446

The diesel engine serial number plate (B) is located on top of the valve cover.

# SPECIFICATIONS AND INFORMATION INTERLOCK SYSTEM

## Interlock System

### Interlock System

It is important to understand the interlock system and how it works. Before performing the checkout procedures, become familiar with the interlock system so that an interlock function will not be mistaken for a machine problem.

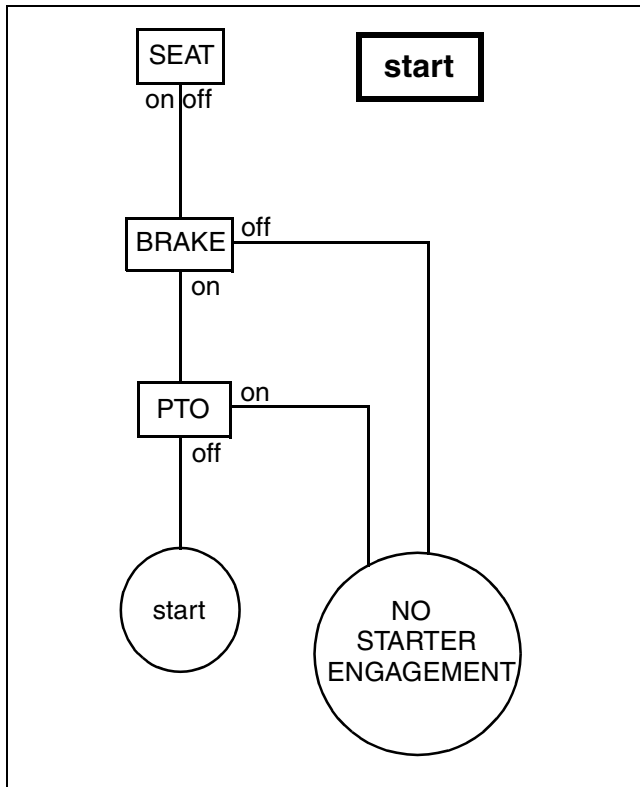

MIF MX5726

For the starting motor to engage and the engine to run, the following conditions must be met simultaneously:

- Operator on seat and park brake locked.
- PTO switch in off position.

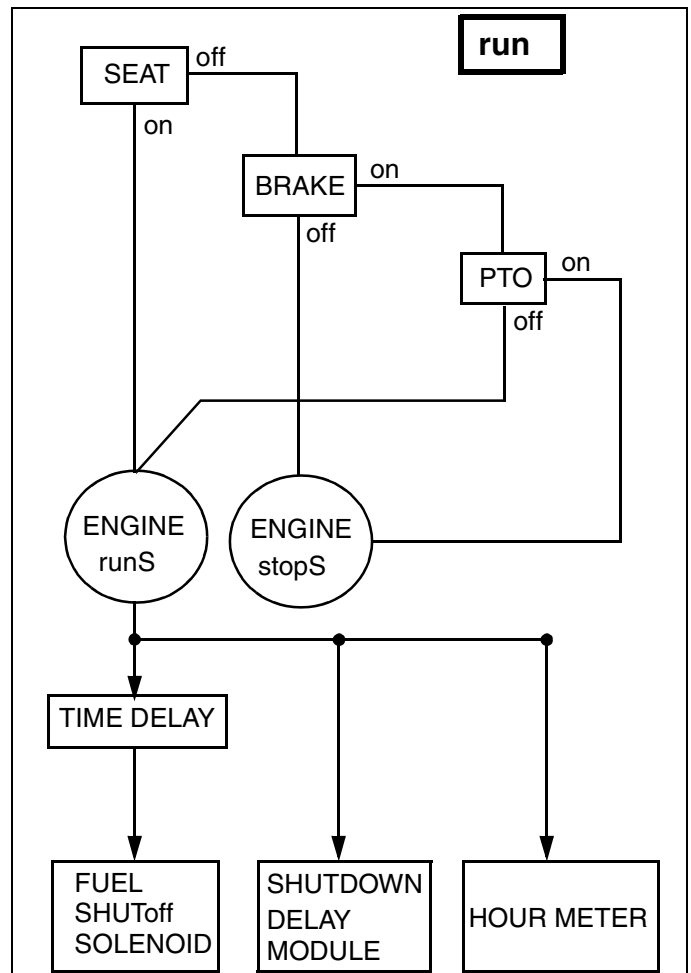

MIF MX5736

For the engine to run, one of the following must occur:

- Operator must be on seat when PTO is engaged and/or park brake is unlocked.
- When operator is not on seat, the PTO must be disengaged and park brake locked.

When the park brake is unlocked and the operator rises off the seat, the engine will stop.

If the operator is operating an attachment and rises off the seat, the attachment and engine will stop.

In order to operate attachments, the following conditions must occur:

- Operator sitting on operator seat.
- Throttle lever moved to the fast position.
- Park brake unlocked.
- PTO switch in the on position.

If the operator is operating attachments and the park brake is depressed, the attachment will stop operating. The PTO switch must be cycled (Off/On) before attachment will operate.

**SPECIFICATIONS AND INFORMATION INTERLOCK SYSTEM**

---

---

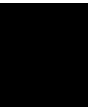

# ENGINE - GAS TABLE OF CONTENTS

## Table of Contents

### Specifications .....27

General Specifications .....	27
Test and Adjustment Specifications .....	27
Repair Specifications.....	28
Torque Specifications.....	30
Special or Required Tools .....	31
Other Materials.....	31
Available Kits.....	31

### Diagnostics .....32

Engine Troubleshooting Guide.....	32
Starting Motor Troubleshooting Guide .....	34

### Tests and Adjustments .....35

Alternator Belt Tension Check and Adjustment .....	35
Throttle Cable and Governor Adjustment.....	35
Choke Cable Adjustment.....	36
Slow Idle Speed Adjustment .....	36
Fast Idle Speed Adjustment .....	37
Throttle Start Position Screw Adjustment.....	38
Valve Clearance Adjustment .....	39
Cooling System Pressure Test.....	40
Fuel Pump Pressure Test.....	40
Fuel Pump Flow Test .....	41
Oil Pressure Test.....	42
Cylinder Compression Test .....	43
Radiator Cap Pressure Test.....	43
Thermostat Opening Test.....	44
Radiator Bubble Test.....	45

### Repair.....45

Carburetor Removal and Replacement.....	45
Carburetor Inspection.....	46
High Altitude Jet Installation .....	48
Radiator Removal, Installation and Inspection .....	48
Thermostat Removal and Installation.....	50
Water Pump Removal and Installation (Thermostat Included) .....	51
Fuel Filter Removal and Installation.....	52
Throttle Cable Assembly Removal and Installation .....	53
Choke Cable Assembly Removal and Installation .....	53
Fuel Pump Removal and Installation.....	54
Engine Removal and Installation.....	55

Flywheel Removal and Installation .....	58
Rocker Arm Cover Removal and Installation.....	59
Rocker Arm and Push Rods .....	60
Cylinder Head Removal and Installation.....	62
Exhaust Manifold Removal and Installation.	63
Intake Manifold Removal and Installation ....	63
Cylinder Head Recondition .....	64
Oil Pan and Strainer .....	68
Oil Pressure Regulating Valve.....	69
Oil Pump .....	69
Timing Gear Cover Removal and Installation.....	70
Timing Gear Backlash Check .....	71
Camshaft End Play Check.....	72
Camshaft .....	73
Governor Removal, Inspection and Installation.....	76
Piston and Connecting Rod Removal and Installation.....	79
Connecting Rod Bearing Clearance Check.	80
Connecting Rod Side Play Check.....	81
Cylinder Bore .....	86
Crankshaft and Main Bearings .....	88
Crankshaft Rear Oil Seal .....	91

# ENGINE - GAS TABLE OF CONTENTS

Product: John Deere 1420, 1435, 1445, 1545, 1565 Front Mowers Service Repair Technical Manual

Full Download: <https://www.bobmanualstore.com/downloads/john-deere-1420-1435-1445-1545-1565-front-mowers-service-repair-technical-manual>

/

Sample manual. Download All 834 pages at:

<https://www.bobmanualstore.com/downloads/john-deere-1420-1435-1445-1545-1565-front-mowers-service-repair-technical-manual>